

IPDiA Sample Kit 935181002006 Data Sheet

Designation	type	Unit/T&R	P/N
XTSC 0402	1nF	10 to 20	935,133,424,410
XTSC 0402	10nF	10 to 20	935,133,424,510
XTSC 0402	33nF	10 to 20	935,133,424,533



XTSC424.xxx - 0402 Extreme Temperature Silicon Capacitor

Rev 3.1

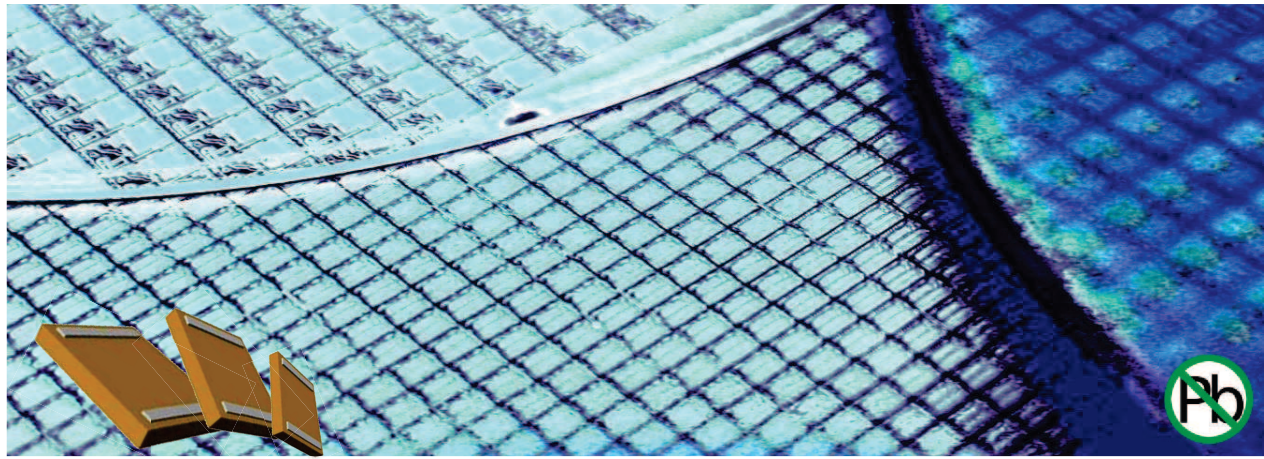

Key features

- Ultra High temperature up to 250°C:
 - ◆ Temperature Coeff : $<\pm 1.5\%$ (-55 °C to +250°C)
 - ◆ Voltage $<0.1\%$ /V
 - ◆ Negligible capacitance loss through aging
- Unique high capacitance in EIA/0402 package size, up to 100 nF
- High reliability (FIT <0.017 parts / billion hours)
- Low leakage current down to 100 pA
- Low ESL and Low ESR
- Suitable for lead free reflow-soldering *Please refer to our assembly Application Note for further recommendations

Thanks to the unique IPDiA Silicon capacitor technology, most of the problems encountered in demanding applications can be solved.

EXtreme Temperature Silicon Capacitors are appropriate for applications used in extreme operating temperature range (up to **250°C**).

XTSC industry leading performances allow to propose a **100nF in 0402** with a **TC $<\pm 1.5\%$** over the full -55°C/+250°C temperature range.

This technology also offers a **negligible ageing** and a stable insulation resistance, even at very high temperature, as well as a stable capacitor value over the full operating.

Key applications

- 250°C requirements, High temperature applications, such as military, aerospace, automotive and downhole industries.
- High reliability applications
- Replacement of X8R and C0G dielectrics
- Decoupling / Filtering / Charge pump (i.e.: pressure sensor, motor management)
- Downsizing

The IPDiA technology features a capacitor integration capability (up to 250nF/mm²) which allows a capacitance value similar to X8R dielectric, but with better electrical performances than C0G/NP0 dielectrics.

This technology also offers **high reliability**, up to 10 times better than alternative capacitor technologies, such as Tantalum or MLCC, and eliminates cracking phenomena.

This Silicon based technology is RoHS compliant and compatible with lead free reflow soldering process.

Electrical specification

		Capacitance value					
		10	15	22	33	47	68
Unit	1 pF	Contact IPDIA Sales	Contact IPDIA Sales	Contact IPDIA Sales	Contact IPDIA Sales	Contact IPDIA Sales	Contact IPDIA Sales
	10 pF	100 pF: 935.133.424.310	150 pF: 935.133.424.315	220 pF: 935.133.424.322	330 pF: 935.133.424.333	470 pF: 935.133.424.347	680 pF: 935.133.424.368
	0.1 nF	1 nF: 935.133.424.410	1.5 nF: 935.133.424.415	2.2 nF: 935.133.424.422	3.3 nF: 935.133.424.433	4.7 nF: 935.133.424.447	6.8 nF: 935.133.424.468
	1 nF	10 nF: 935.133.424.510	15 nF: 935.133.424.515	22 nF: 935.133.424.522	33 nF: 935.133.424.533	47 nF: 935.133.424.547	Contact IPDIA Sales
	10 nF	100 nF: 935.133.424.610					

Parameters	Value
Capacitance range	100pF to 100 nF ^(*)
Capacitance tolerances	±15 % ^(**)
Operating temperature range	-55 °C to 250 °C
Storage temperatures	-70 °C to 265 °C
Temperature coefficient	<±1.5 %, from -55 °C to +250 °C
Breakdown voltage (BV)	11 VDC, 30VDC
Capacitance variation versus RVDC	0.1 % /V (from 0 V to RVDC)
Equivalent Serial Inductor (ESL)	Max 100 pH
Equivalent Serial Resistor (ESR)	Max 400mΩ ^(**)
Insulation resistance	50GΩ min @ 3V, 25°C 10GΩ min @ 3V, 250°C
Ageing	Negligible, < 0.001 % / 1000 h
Reliability	FIT<0.017 parts / billion hours,
Capacitor height	Max 400 μm ^(*)

(*) Thinner thickness (as low as 100 μm thick) available, see Low Profile Silicon Capacitor product: LPSC

(**) Other values on request.

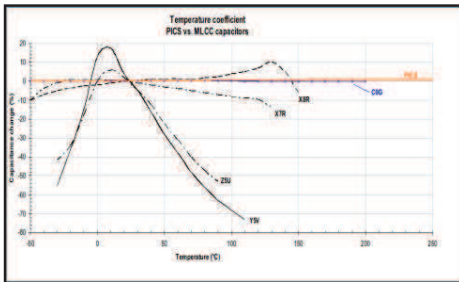

Fig.1 Capacitance change versus temperature variation compared with alternative dielectrics

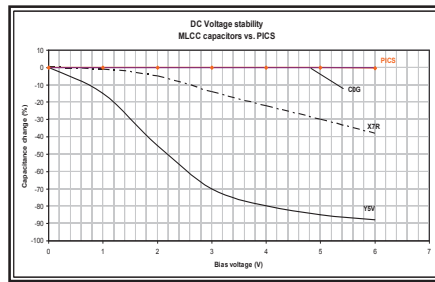

Fig.2 Capacitance change versus voltage variation compared with alternative dielectrics

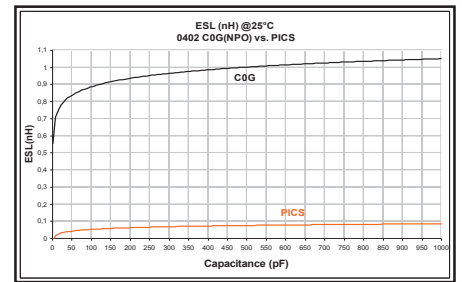

Fig.3 ESL versus capacitance value compared with alternative dielectrics

Part Number

935.133.

i.e.: 47 nF/0402 case (XTSC type)
→ 935.133.424.547

B.2 → Breakdown Voltage
4 = 11V
7 = 30V

S. → Size
4 = 0402

U → Unit
0 = 10 f 5 = 1 n
1 = 0.1 p 6 = 10 n
2 = 1 p 7 = 0.1 μ
3 = 10 p 8 = 1 μ
4 = 0.1 n 9 = 10 μ

XX → Value (E6)
10
15
22
33
47
68

Termination and Outline

Termination

Lead-free nickel/solder coating compatible with automatic soldering technologies: reflow and manual

Typical dimensions, all dimensions in mm

Package outline

Typ.		0402
Comp. size	L	1.20±0.05
	W	0.70±0.05

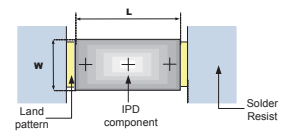

(0402 PCB footprint)

Packaging

Tape and reel, tray, waffle pack or wafer delivery

Reproduction in whole or in part is prohibited without the prior written consent of the copyright owner. The information presented in this document does not form part of any quotation or contract, is believed to be accurate and reliable and may be changed without notice. No liability will be accepted by the publisher for any consequence of its use. Publication thereof does not convey nor imply any license under patent- or other industrial or intellectual property rights.



For more information, please visit: <http://www.ipdia.com>
To contact us, email to: sales@ipdia.com

Date of release: 28th February 2014
Document identifier: CL431 111 615 122



IPD Capacitor Assembly Set Up

Rev 1.0

Application Note

Outline

Silicon Capacitor for surface mounting device (SMD) assembly is a Wafer Level Chip Scale Packaging with the following features:

- Package dedicated to solve tombstoning effect of small SMD package;
- Package compatible with SMD assembly;
- Package without underfilling step;
- Interconnect available with various optional finishing for specific assembly.

Assembly consideration

- Standard pick & place equipment dedicated to WLCSP down to 400µm pitch.
- Solder paste type 3 in most cases of EIA size.
- Reflow has to be done with standard lead-free profile (for SAC alloys) or according to JEDEC recommendations J-STD 020D-01.

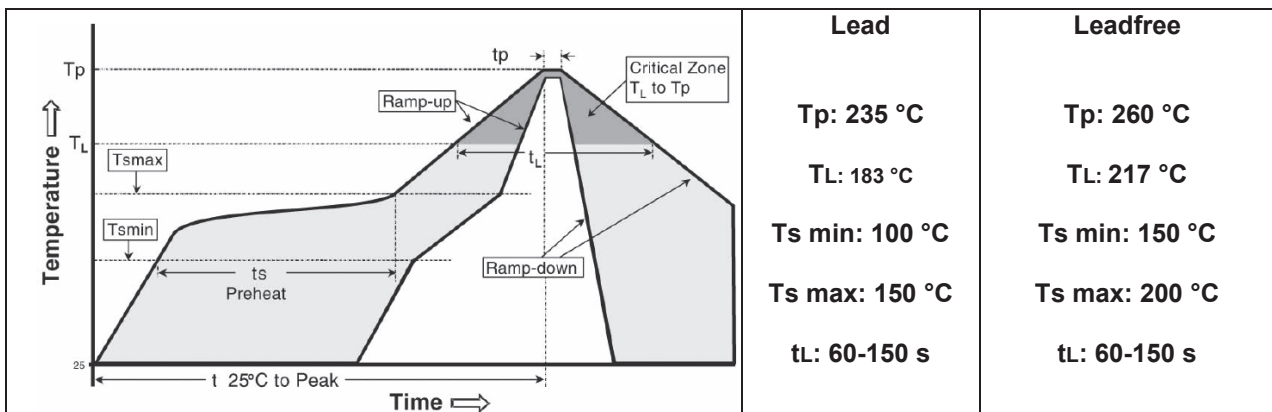

Process recommendation

After soldering, no solder paste should touch the side of the capacitor die as that might result in leakage currents due to remaining flux.

In order to use IPDiA standard capacitors within the JEDEC format and recommendation, the solder flux must be cleaned after reflow soldering step.

Notes: for a proper flux cleaning process, "rosin" flux type (R) or "water soluble" flux type (WS) is recommended for the solder printing material. "No clean" flux (NC) solder paste is not recommended.

In case the flux is not cleaned after the reflow soldering, the standard JEDEC would probably not be appropriate and the solder volume must be controlled:

- using smallest aperture design for the stencil, and using finer solder paste type 4 or 5 for a proper printing process.
- Mirroring pads would be the best recommendation

Pad recommendation

The capacitor is compatible with generic requirements for flip chip design (IPC7094). Standard IPDiA 3D package can be compliant with established EIA size (0201, 0402, 0603, ...).

Die size and land pattern dimensions is set up according to following range :

EIA size	0201	0402	0603	0805	1206	1812
Dimension max(X1 x X2) mm	0.86x0.66	1.26x0.76	1.86x1.16	2.26x1.46	3.46x1.86	4.76x3.66
Typical . die thickness X3 (mm)	0.1 or 0.4					
Typical pad size* (mm)	0.15x0.40	0.30x0.50	0.40x0.90	0.50x1.20	0.60x1.60	0.90x3.40
Typical pad separation (X4 mm)	0.3	0.4	0.8	1	2	2.7

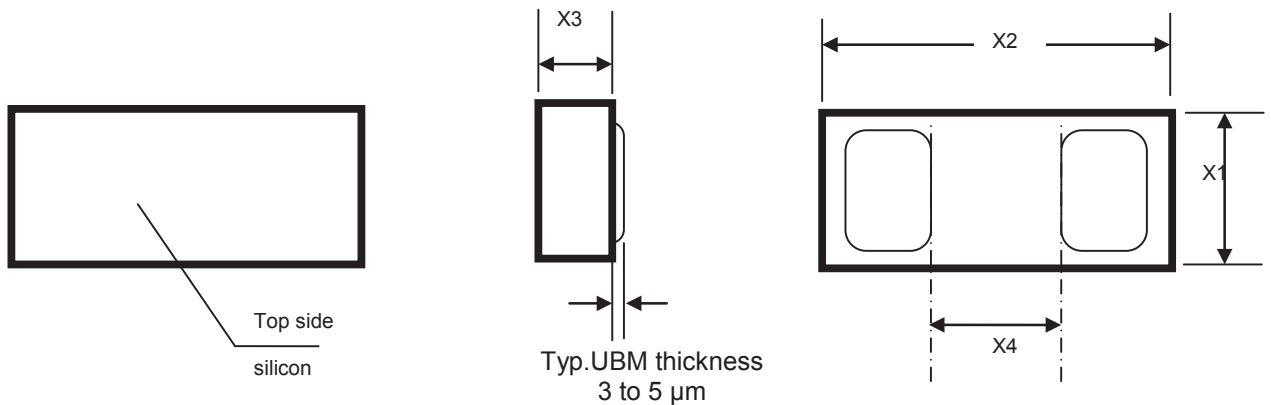

After soldering, no solder paste should touch the side of the capacitor die as that might result in leakage currents due to remaining flux.

Manual Handling Considerations

These capacitors are designed to be mounted with a standard SMT line, using solder printing step, pick and place machine and a final reflow soldering step. In case of manual handling and mounting conditions, please follow below recommendations:

- Minimize mechanical pressure on the capacitors (use of a vacuum nozzle is recommended).
- Use of organic tip instead of metal tip for the nozzle.
- Minimize temperature shocks (Substrate pre-heating is recommended).
- No wire bonding on 0402 47nF, 0402 100nF, 1206 1 μ F and 1812 3,3 μ F

Process steps:

- On substrate, form the solder meniscus on each land pattern targeting 100 μ m height after reflow (screen printing, dispensing solder paste or by wire soldering).
- Pick the capacitor from the tape & reel or the Gel Pack keeping backside visible using a vacuum nozzle and organic tip.
- Temporary place the capacitor on land pattern assuming the solder paste (Flux) will stick and maintain the capacitor.
- Reflow the assembly module with a dedicated thermal profile (see reflow recommendation profile).

X-ON Electronics

Largest Supplier of Electrical and Electronic Components

Click to view similar products for [Capacitor Kits](#) category:

Click to view products by [IPDiA](#) manufacturer:

Other Similar products are found below :

[1320838-1](#) [DK0035T](#) [KITMS11111](#) [DK0026T](#) [DK0027T](#) [DK0033T](#) [DK0034T](#) [TS0002](#) [MICA-KIT2](#) [MICA-KIT1](#) [KIT-FOLDERPOLYMER](#) [MICA-KIT6](#) [UL-0603-KITSET34-AB](#) [ALU ENG KIT 07](#) [EKSM-PDADA1A-KIT](#) [GRM03-KIT-CLASS2-DE](#) [MKV250V-KIT-1-DE](#) [MKV250V-KIT-2-DE](#) [KIT MKS](#) [KITTYPE1700 LF](#) [GCJ-KIT-X7-DE-A](#) [GCM-KIT-X7-DE-B](#) [GJM03-KIT-100V-DE](#) [GCJ-KIT-X7-DE-B](#) [GRM02-KIT-TTOL-DE](#) [GRM02-KIT-DE](#) [LL-NFM-KIT-DE-C](#) [EKSM-PND51X22B-KIT](#) [ACCU-P0402KITL1](#) [KITTYPE1400 LF](#) [KITTYPE2100 LF](#) [KITTYPE900 LF](#) [KITMS08051](#) [DK0025T](#) [Ultra Low ESR Kit 1](#) [KITTYPE2700 LF](#) [KITTYPE2800 LF](#) [VJ1111QUARF1KIT](#) [VJ0505QUARF2KIT](#) [AY21-KIT-HF](#) [MCF500VKIT5](#) [ACCU-P0805KITL2](#) [KIT3000UZ](#) [KIT4000UZ](#) [885090](#) [885341](#) [VJ1111QUARF3KIT](#) [VJ1111QUARF2KIT](#) [VJ0505QUARF1KIT](#) [PPR ENG KIT 03](#)