

# OSCILLATOR EVALUATION BOARD DOCUMENTATION

OCTOBER 2018

**Model Code:**

IOSC-EVBoard

**Ordering code:**

LFMISC079433BULK Unpopulated PCB

Mouser Part No: 449-LFMISC079433BULK

**Latest version of this documentation available from:**

[www.iqdfp.com/evb/](http://www.iqdfp.com/evb/)

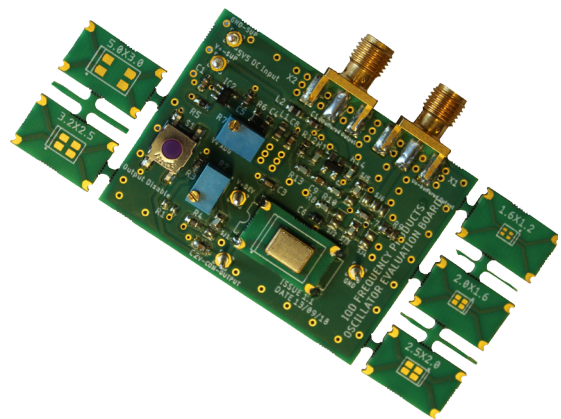
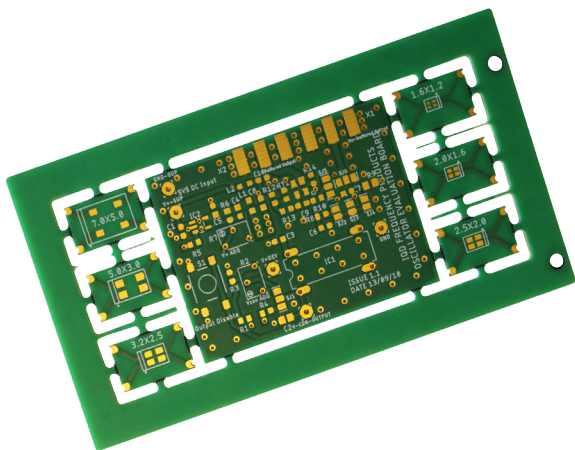

---

**Contact Details:**

UK: +44 (0)1460 270 200  
Germany: 0800 1808 443

France: 0800 901 383  
USA: +1.760.318.2824

Email: [info@iqdfrequencyproducts.com](mailto:info@iqdfrequencyproducts.com)  
Web: [www.iqdfrequencyproducts.com](http://www.iqdfrequencyproducts.com)



---

## INTRODUCTION

Designed by IQD Frequency Products utilising over 40 years of oscillator testing measurement experience, the oscillator evaluation board is intended to facilitate basic testing of standard oscillators, voltage controlled oscillators and temperature compensated oscillators. The board can provide a regulated power supply to the oscillator between 1.8V and 5.0V. A buffered output with the correct loading is provided for CMOS output devices or clipped sine wave output devices. There is also an unbuffered output for further testing. There is capability to test the enable disable function, and also to control the voltage input of a voltage controlled crystal oscillator product.

## FEATURES

- Suitable for Clock Oscillators (SPXO), VCXO, TCXO and VCTCXO product types
- Suitable for standard four pad devices in 7.0 x 5.0mm, 5.0 x 3.2mm, 3.2 x 2.5mm 2.5 x 2.0mm 2.0 x 1.6mm or 1.6 x 1.2mm packages
- On board regulated power supply for products with supply voltages between 1.8V to 5.0V
- Buffered and correctly loaded output for CMOS, clipped sine and 50Ω type devices
- Input disable test system incorporated
- Voltage control adjustment incorporated
- Simple configuration for all options
- Connections for off board control inputs and outputs provided

---

### Contact Details:

UK: +44 (0)1460 270 200  
Germany: 0800 1808 443

France: 0800 901 383  
USA: +1.760.318.2824

Email: [info@iqdfrequencyproducts.com](mailto:info@iqdfrequencyproducts.com)  
Web: [www.iqdfrequencyproducts.com](http://www.iqdfrequencyproducts.com)

# CONTENTS

INTRODUCTION.....	2
FEATURES.....	2
TABLE OF CONTENT.....	3
GLOSSARY.....	4
DUT PLACEMENT.....	5
POWER SUPPLY.....	6
USING THE IOSC-EVBOARD ON BOARD REGULATOR.....	6
USING EXTERNAL POWER SOURCE TO THE DUT.....	7
ENABLE/DISABLE OR STANDBY FUNCTION.....	8
VOLTAGE CONTROL FUNCTION.....	9
OSCILLATOR OUTPUT CONFIGURATION.....	10
15PF LOAD BUFFERED INTO 50OHMS RECOMMENDED FOR CMOS DEVICES.....	11
10KΩ//10PF LOAD BUFFERED INTO 50OHMS RECOMMENDED FOR CLIPPED SINEWAVE DEVICES.....	11
50Ω UNBUFFERED INTO HIGH IMPEDANCE FOR SINEWAVE OUTPUT DEVICES.....	11
RAW OSCILLATOR OUTPUT, RECOMMENDED FOR ADVANCED USERS.....	11
15PF OR 10KΩ//10PF OR 50Ω LOAD BUT NO BUFFER.....	11
BILL OF MATERIALS.....	12
PCB LAYERS.....	13
OVER LAYER.....	13
TOP LAYER.....	13
2ND LAYER GRN.....	14
3RD LAYER V+.....	14
BOTTOM LAYER.....	15
FULL CIRCUIT DIAGRAM.....	16
IOSC-EVBOARD IMPORTANT NOTICE.....	17

## GLOSSARY

DUT	Device under test
SPXO	Simple Packaged crystal oscillator also known as a clock oscillator
TCXO	Temperature compensated crystal oscillator with no voltage control function
VCTCXO	Temperature compensated crystal oscillator with voltage control function
VCXO	Voltage controlled crystal oscillator
OCXO	Oven controlled crystal oscillator

## DUT PLACEMENT

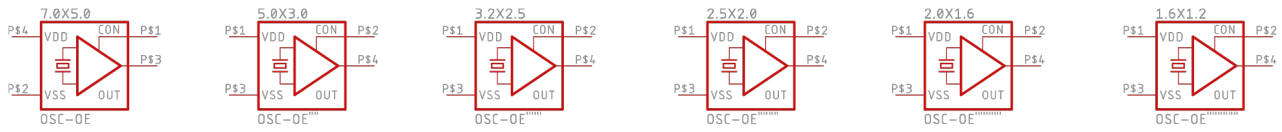

To affix your chosen oscillator to the PCB and facilitate use of the IOSC-EVBoard first select the correct break out PCB from the six available along the edges of the IOSC-EVBoard. Position on the main PCB at IC1 and solder the four castellations on the edge of the PCB.

Take the oscillator to be tested and solder directly to the pads on the break out board. Observe the polarity of the oscillator to the main PCB.

## POWER SUPPLY

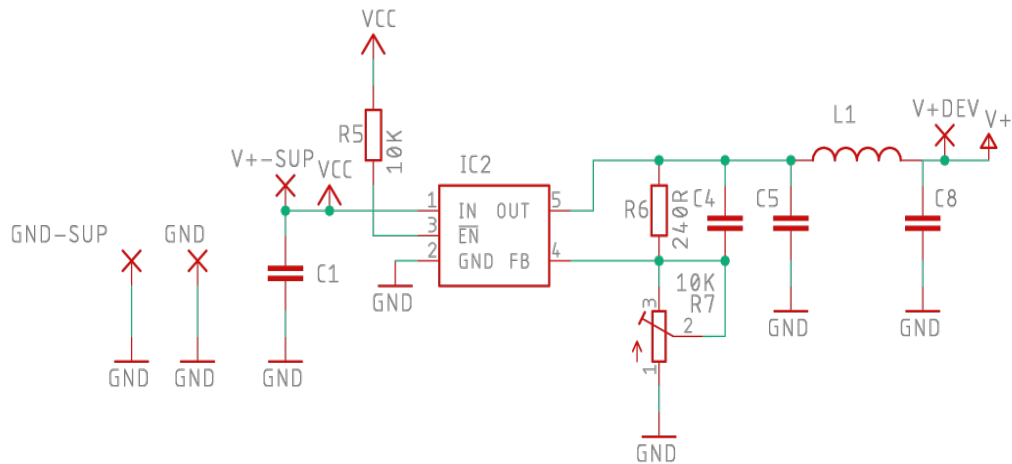

Crystal oscillators are used for frequency control in electronics for many reasons including their very low noise levels. However an oscillator's performance can be significantly degraded by power supply noise. Using low cost switch mode power supplies with internal switching in the kHz range can create frequency distortion on the output of the oscillator.

The on board regulator within the oscillator IC must try and reduce the noise within the oscillator circuit. To do this the excess voltage is turned into heat. This heating instability causes a frequency vs temperature effect on the crystal which translates into a frequency stability error in measurement.

For tight stability products such as VCTCXO products this effect can cause the frequency to move close to the specified limits of the product.

### USING THE IOSC-EVBOARD ON BOARD REGULATOR

The IOSC-EVBoard contains an on board voltage regulator circuit which is adjustable via a potentiometer to provide a regulated supply voltage to the oscillator. An external power supply of 5.5V must be provided to the input pins labelled V+ -SUP and GND -SUP. It is recommended that a low noise power supply is used here. The on board regulator circuit output provides the power supply to the DUT. Potentiometer R7 is used to adjust the voltage output of the regulator. The output voltage is filtered through network C5L1 and C8 to give a low noise power source to the DUT, V+. This can be monitored at connector V+DEV.

Note: In this configuration the current drawn at V+DEV includes regulators and buffers therefore is not current draw of the oscillator alone.

## **USING EXTERNAL POWER SOURCE TO THE DUT**

To remove the function of the on board regulator and provide power directly to the DUT from an external power supply the connection V+DEV can be used as an input and Inductor L1 should be removed to isolate the unused regulator from the circuit.

If the output buffer circuit of the IOSC-EVBoard is to be used (See oscillator output configuration section for details), then it is still necessary to supply 5.5VDC to V+SUP to drive the buffer circuit.

Note: In this configuration the current draw observed on V+DEV includes the drive to the enable/disable circuit around Pad1.

## ENABLE/DISABLE OR STANDBY FUNCTION

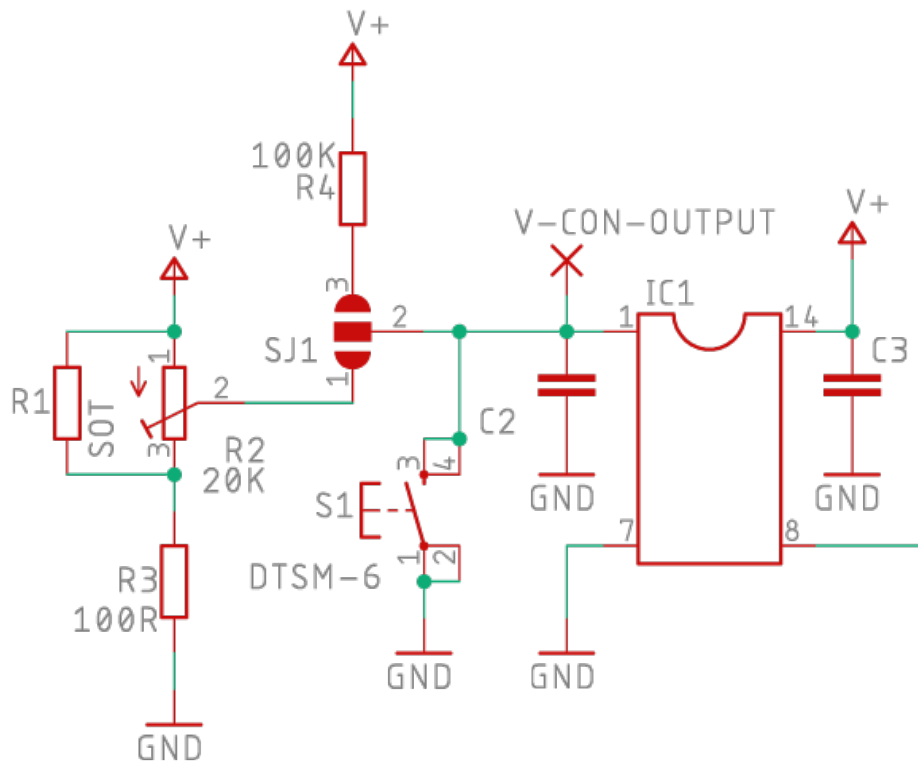

Most SPXO and TCXO products include a function to stop the output of the device by inputting a logic 1 or logic 0 to Pad 1 of the oscillator.

In some oscillators this function disables the output buffer but leaves the internal oscillator circuit running. This gives fast enable time, but little current saving when disabled. In some oscillators this function stops the internal oscillator. This gives larger current saving when disabled, but a slower enable time.

The IOSC-EVBoard includes a circuit to test this function.

Use a zero ohm link to make the connection between SJ1 pin 2 and 3.

R4 now pulls the oscillator input high, and the oscillator is enabled by default. Activate switch S1 to pull the logic level low and so disable the oscillator.

The status of the logic level can be monitored at connector V-CON-OUTPUT.

For control of this function via some external circuitry use V-CON-OUTPUT as an input.



## VOLTAGE CONTROL FUNCTION

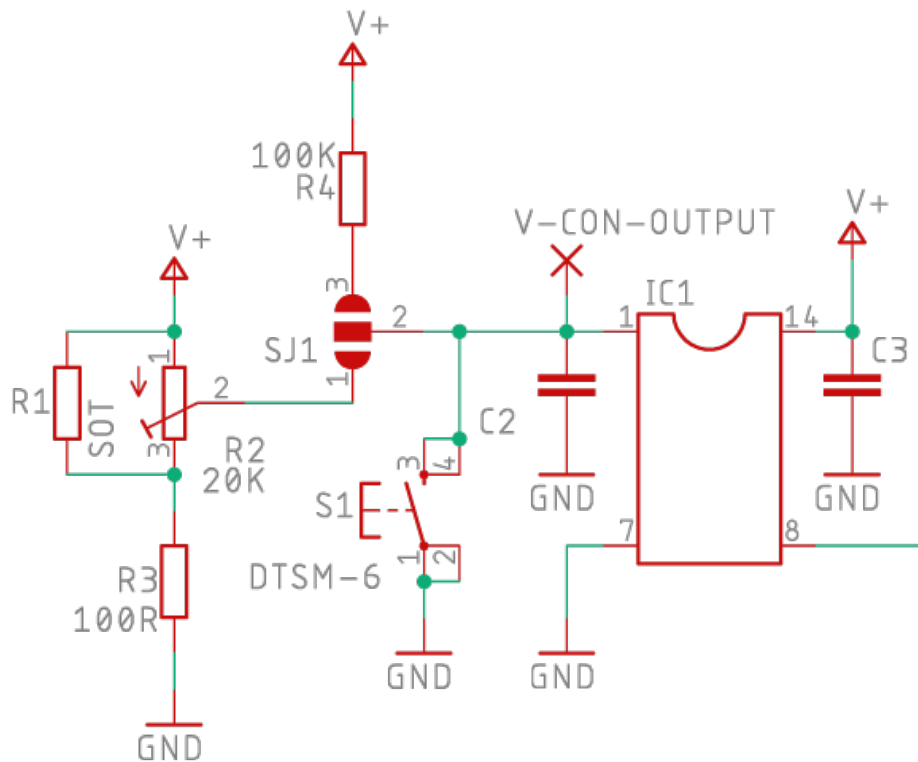

A VCXO uses a DC analogue input level to control the frequency of the oscillator output. As the DC level is changed the frequency is pulled higher or lower proportionally. On a VCXO product this pulling effect may be in the range +/-50ppm to +/-200ppm. On a VCTCXO product this pulling effect may be in the range +/-1ppm to +/-15ppm. The function can be used to tune the frequency of one oscillator to match the frequency of another oscillator. The pulling function of a crystal oscillator is achieved by use of a varicap diode in the capacitive load circuit of the oscillator. As the input to the varicap diode is varied so the capacitive load seen by the crystal varies, this pulls the resonant frequency of the circuit.

There are a number of different parameters of this function which may need to be evaluated. For example: total pulling in positive and negative direction, linearity of pulling response, maximum modulation bandwidth. The IOSC-EVBoard can be used for this evaluation work.

Use a zero ohm link to make the connection on SJ1 between Pad1 and 2.

Monitor the DC voltage level input to the oscillator on V-CON-OUTPUT.

Adjust the potentiometer R2 to change the DC voltage levels. The DC level can be varied between V+ and GND.

Note: Observe the data sheet for your device under test and ensure that the DC voltage input on V-CON-OUTPUT stays within the levels on the datasheet.

Any noise on the DC input to the oscillator will translate directly into frequency change on the oscillator output. The potentiometer R2 may be a source of noise. To remove this source of noise remove R2 and replace with a fixed resistor value in position R1.

For VCTCXO products the pulling function is often used only to trim out the effect of the manufacturing stresses on the product, this may be done in manufacturing using a select on test resistor. This process can be recreated on the IOSC-EVBoard by adjusting R2 until the frequency is pulled to the nominal, then removing R2, measuring the resistor value and populating position R1 with values to equal that of R2

## OSCILLATOR OUTPUT CONFIGURATION

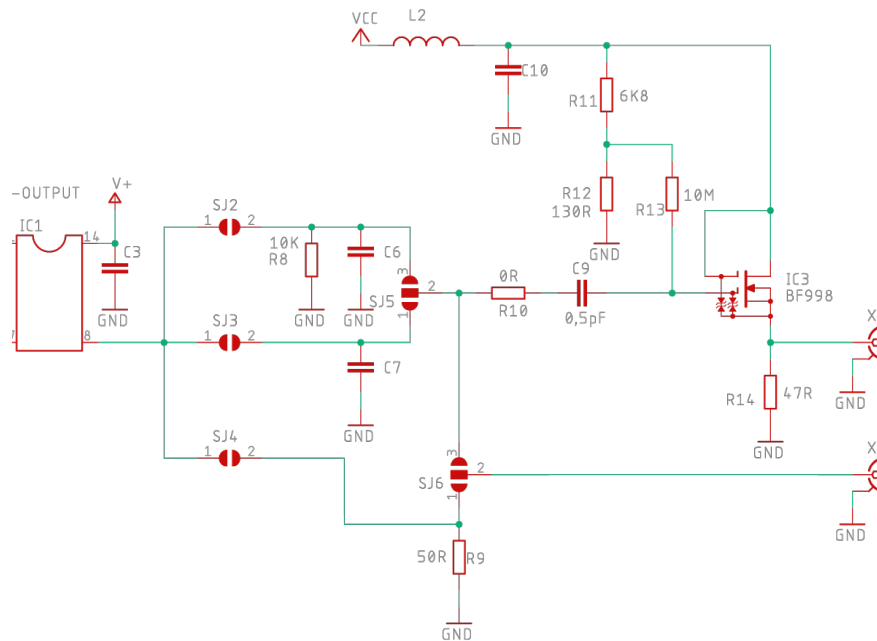

For optimum performance oscillators must have correct loading between the RF output and the input of the following device. Incorrect loading can result in increased current draw within the oscillator which can cause internal heating and thus affect the frequency stability.

Test and Measurement equipment also requires correct loading and termination to optimise the signal. But low capacitance probes are high cost and not always within an engineers budget.

The IOSC-EVBoard is designed to provide a selection of standard oscillator output load configurations and terminate these into a standard 50Ω SMA connector to simplify the test and measurement setup.

The following configurations are possible:

- 15pF load buffered into 50Ω recommended for CMOS devices
- 10kΩ//10pF load buffered into 50Ω recommended for clipped sinewave devices
- 50Ω unbuffered into high impedance recommended for Sinewave output devices
- Raw oscillator output recommended for advanced users
- 15pF or 10kΩ//10pF or 50Ω load with no buffer

The following sections detail the configuration of each of these options.

Note: The purpose of the buffered output stage employed in the circuit is not gain, but isolation between the device under test and the measurement equipment, this loads the device under test with very low capacitance and high DC resistance while matching the measurement equipment input to 50Ω. Therefore there is a reduction in the output signal amplitude of approximately 20dB

### **15PF LOAD BUFFERED INTO 50OHMS RECOMMENDED FOR CMOS DEVICES**

The most common output available from standard oscillators is a square wave generated from an internal CMOS buffer. For these types of products the data sheet will most commonly give values for the device when measured in a test circuit presenting 15pF to the oscillator RF output.

The capacitance on the RF output acts as a filter with different delay and attenuation figures for the different harmonic content of the square wave and thus affects the rise and fall time, ringing and duty cycle. 15pF is higher than the combination of the input capacitance of most IC's and the PCB stray capacitance thus testing at 15pF provides a reproducible method for all oscillators with this output type.

To configure the IOSC-EVBoard for testing these type of devices, use a zero ohm link to connect SJ3 and also SJ5 Pads 1 and 2. C7 provides the 15pF load and IC3 provides a buffered output terminated into 50Ω at X2.

### **10KΩ//10PF LOAD BUFFERED INTO 50OHMS RECOMMENDED FOR CLIPPED SINEWAVE DEVICES**

Driving a CMOS buffer takes power and for this reason the buffer is sometimes omitted from the oscillator IC. TCXOs draw higher current than standard oscillators as they need to drive the compensation network. Therefore the output from many TCXO products is unbuffered. This configuration is known as Clipped Sinewave, or Clipped Sine, because of the shape of the waveform seen on the RF output.

Designers wanting to work with clipped sine output oscillators must add some simple circuitry:

A capacitor must be added in series with the output of the oscillator to act as a DC block and isolate the oscillator from the ongoing circuit.

A voltage divider circuit must be added to inject a DC bias to the signal and move it to a voltage level at which the high and low levels sit to either side of the input threshold of the ongoing circuit.

Datasheets for clipped sine output oscillators will normally specify the test circuit as presenting a load of 10kΩ and 10pF in series and terminated to GND.

To configure the IOSC-EVBoard correctly to evaluate this type of oscillator make a zero ohm link across SJ2 and SJ5 Pad 2 and 3. R8 and C6 provide the 10kΩ//10pF load, network R11 R12 and R13 provide the voltage divider and IC3 provides the buffered output terminated into 50Ω at X2.

### **50Ω UNBUFFERED INTO HIGH IMPEDANCE FOR SINEWAVE OUTPUT DEVICES**

Oscillators with true sinewave outputs are rare in new designs unless working with oven controlled crystal oscillators.

Note: The IOSC-EVBoard is not suitable for working with OCXO products because the power supply cannot provide enough current to heat the OCXO.

To configure the IOSC-EVBoard correctly to evaluate this type of oscillator use a zero ohm link across SJ4 and SJ6 Pad 1 and 2.

Note: Test equipment used in this configuration should be set to a high impedance at the input, otherwise the 50Ω at R9 will be in parallel with the 50Ω of the test equipment and give 25Ω. To use a 50Ω input on test equipment remove R9 from the IOSC-EVBoard. Depending on cable length and test configurations, further impedance matching improvements may be achieved using a series 50Ω at the IOSC-EVBoard, or other configurations.

### **RAW OSCILLATOR OUTPUT, RECOMMENDED FOR ADVANCED USERS**

To configure the IOSC-EVBoard correctly to evaluate this type of oscillator use a zero ohm link across SJ4 and SJ6 Pad 1 and 2 and remove R9. The signal is found at X1.

Note: In this configuration the test probe, cables and test equipment form part of the oscillator output loading. It is not recommended to use this configuration unless these values are well understood.

### **15PF OR 10KΩ//10PF OR 50Ω LOAD WITH NO BUFFER**

To configure the IOSC-EVBoard to load the oscillator output but with no buffer follow details above for relevant load but use a zero ohm link on SJ6 Pads 2 and 3 and remove R10. The signal is found at X1.

Note: In this configuration the test probe, cables and test equipment form part of the oscillator output loading. It is not recommended to use this configuration unless these values are well understood.

## BILL OF MATERIALS

Designation	Part Number	Description	Mouser Part No
IC1	SOT		
IC2	TPS73601DBVR	ADJUSTABLE VOLTAGE REG	595-TPS73601DBVR
IC3	BF998E6327HTSA1	MOSFET, N, RF, DUAL-GATE	726-BF998E6327HTSA1
L1	MLZ2012DR10DT	Surface Mount High Frequency Inductor	810-MLZ2012DR10DT000
L2	MLZ2012DR10DT	Surface Mount High Frequency Inductor	810-MLZ2012DR10DT000
R1	SOT	1% 0603 Surface Mount Resistor	
R2	T63YB103KT20	Trimmer Potentiometer, 10 kohm	72-T63YB-10K
R3	100R	1% 0603 Surface Mount Resistor	71-CRCW0603100RFKEAC
R4	100K	1% 0603 Surface Mount Resistor	71-CRCW0603100KJNAIF
R5	10K	1% 0603 Surface Mount Resistor	71-CRCW060310K0DHEAP
R6	1K5	1% 0603 Surface Mount Resistor	71-CRCW06031K50FKEAC
R7	T63YB103KT20	Trimmer Potentiometer, 10 kohm	72-T63YB-10K
R8	10K	1% 0603 Surface Mount Resistor	71-CRCW060310K0DHEAP
R9	50R	1% 0603 Surface Mount Resistor	603-RT0603BRE0750RL
R10	0R	1% 0603 Surface Mount OR link	71-CRCW0603000ZT-RT5
R11	6K8	1% 0603 Surface Mount Resistor	71-RCS06036K80FKEA
R12	130R	1% 0603 Surface Mount Resistor	71-CRCW0603130RFKEAC
R13	10M	1% 0603 Surface Mount Resistor	71-CRCW060310MODHEAP
R14	47R	1% 0603 Surface Mount Resistor	71-CRCW060347R0JNEB
C1	100nF	0603 Surface Mount Ceramic Capacitor X7R	810-CGA3E2X7R1H104K
C2	100nF	0603 Surface Mount Ceramic Capacitor X7R	810-CGA3E2X7R1H104K
C3	100nF	0603 Surface Mount Ceramic Capacitor X7R	810-CGA3E2X7R1H104K
C4	10nF	0603 Surface Mount Ceramic Capacitor X7R	810-C1608X7R1H472KAE
C5	10uF	0603 Surface Mount Ceramic Capacitor X5R	810-C1608X5R0J106KE
C6	10pF	0603 Surface Mount Ceramic Capacitor C0G	810-C1608NP02A100DAA
C7	10pF	0603 Surface Mount Ceramic Capacitor C0G	810-C1608NP02A100DAA
C8	100nF	0603 Surface Mount Ceramic Capacitor X7R	810-CGA3E2X7R1H104K
C9	0.5pF	0603 Surface Mount Ceramic Capacitor C0G	81-GQM1875C2ER50WB2D
C10	10nF	0603 Surface Mount Ceramic Capacitor	810-CGA3E2X7R1H103MA
X1	142-0701-801	Coaxial Connector, SMA Coaxial	530-142-0701-801
X2	142-0701-801	Coaxial Connector, SMA Coaxial	530-142-0701-801
S1	KSEM31G LFS	Tactile Switch SMD	611-KSEM31GLFS
GND-SUP	13.14.119	Press Mount Terminal, Non Insulated	534-1633-2
GND	13.14.119	Press Mount Terminal, Non Insulated	534-1633-2
V+-SUP-IN	13.14.119	Press Mount Terminal, Non Insulated	534-1633-2
V+OUT	13.14.119	Press Mount Terminal, Non Insulated	534-1633-2
VCON-OUTPUT	13.14.119	Press Mount Terminal, Non Insulated	534-1633-2

IC1 and R1 are select on test

PCB LAYERS

OVER LAYER

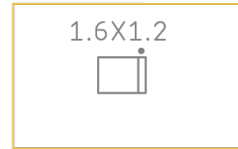
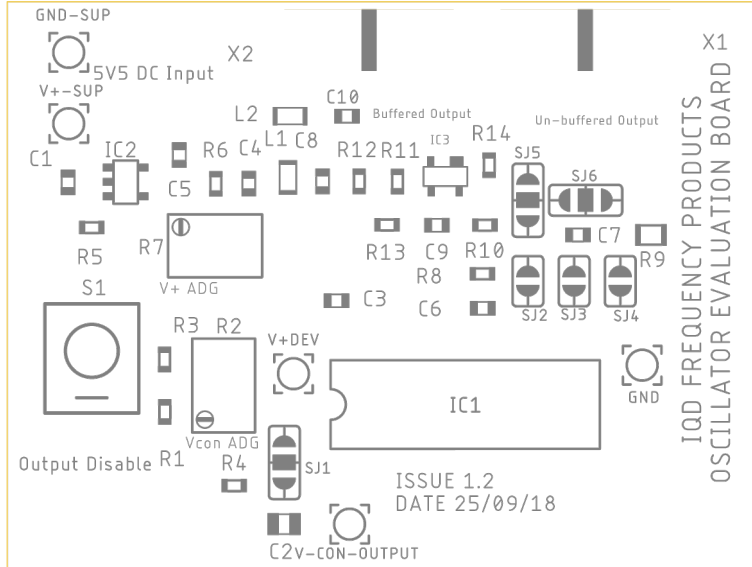
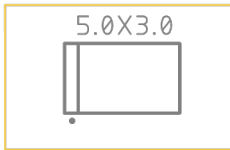
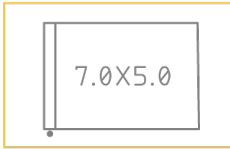

TOP LAYER

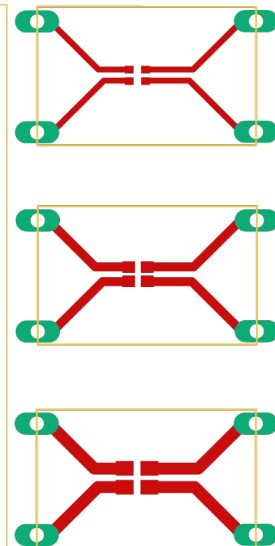
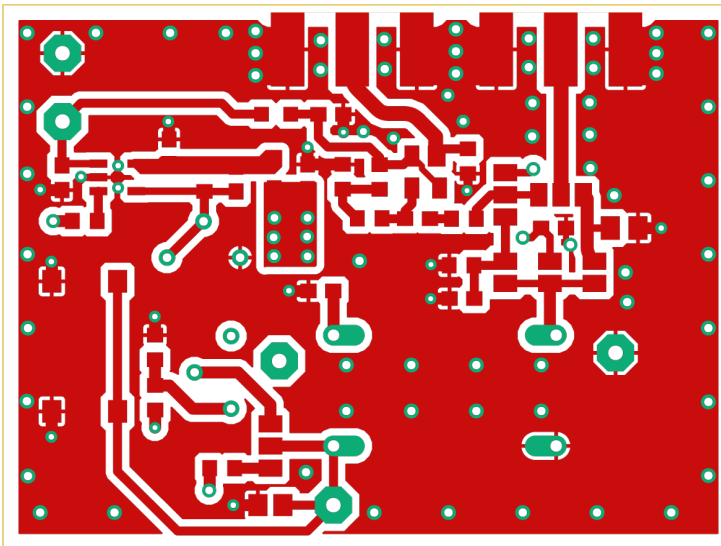
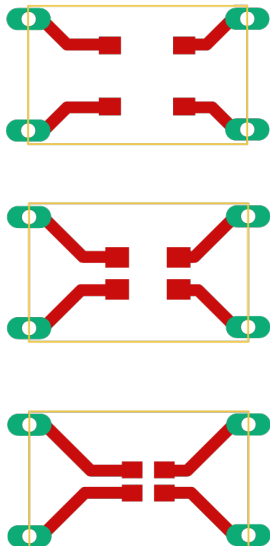

2ND LAYER GRN

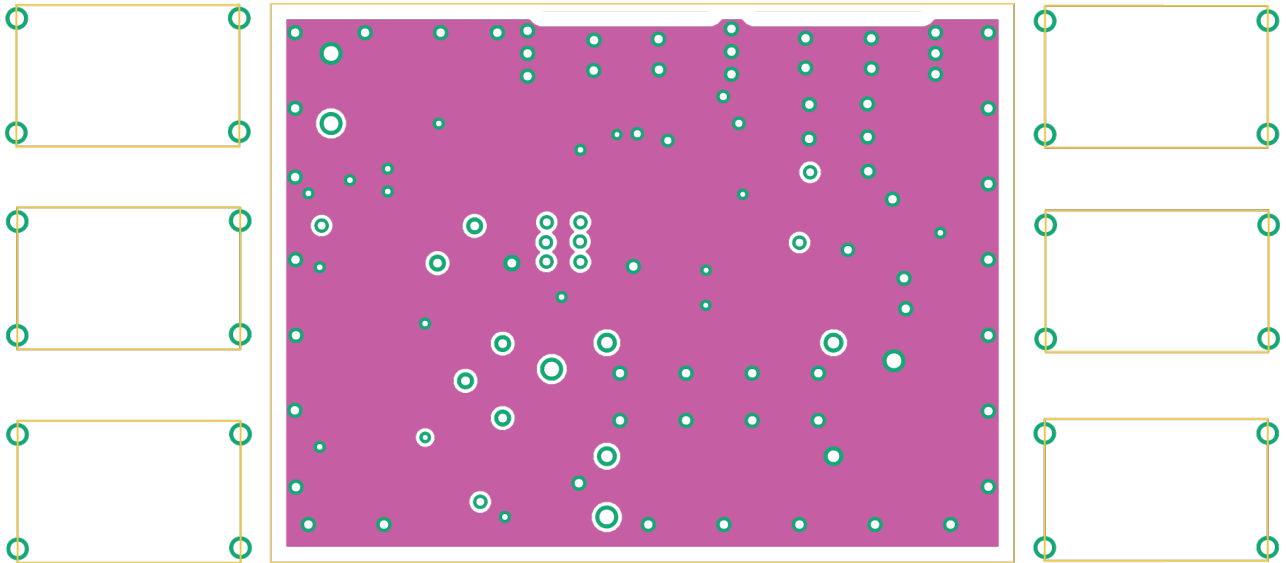

3RD LAYER V+

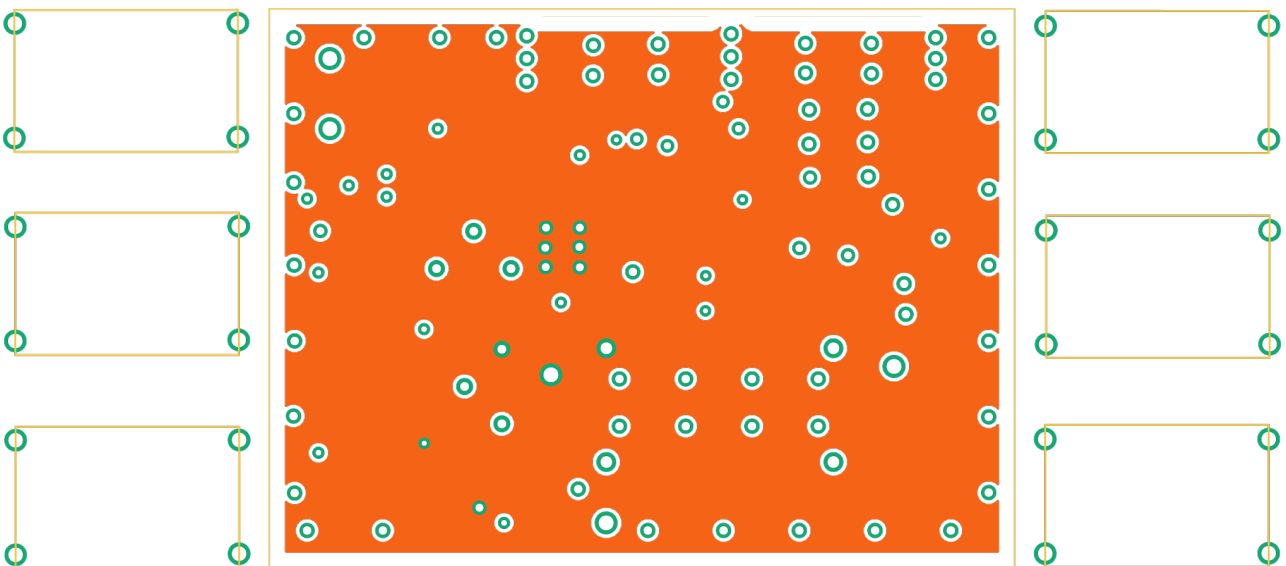

**BOTTOM LAYER**

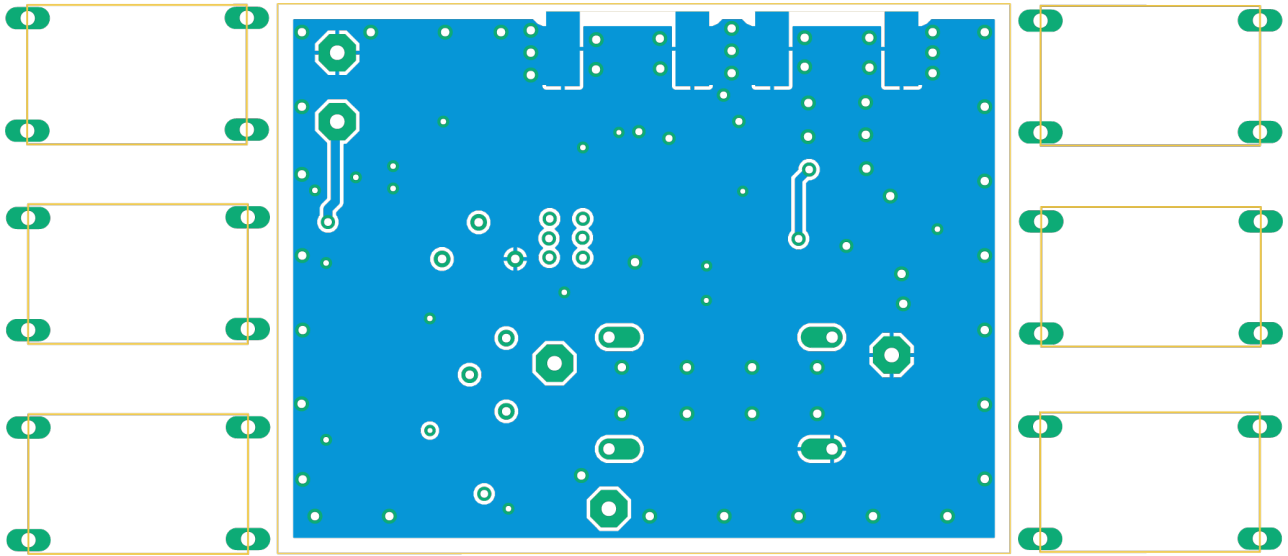

FULL CIRCUIT DIAGRAM

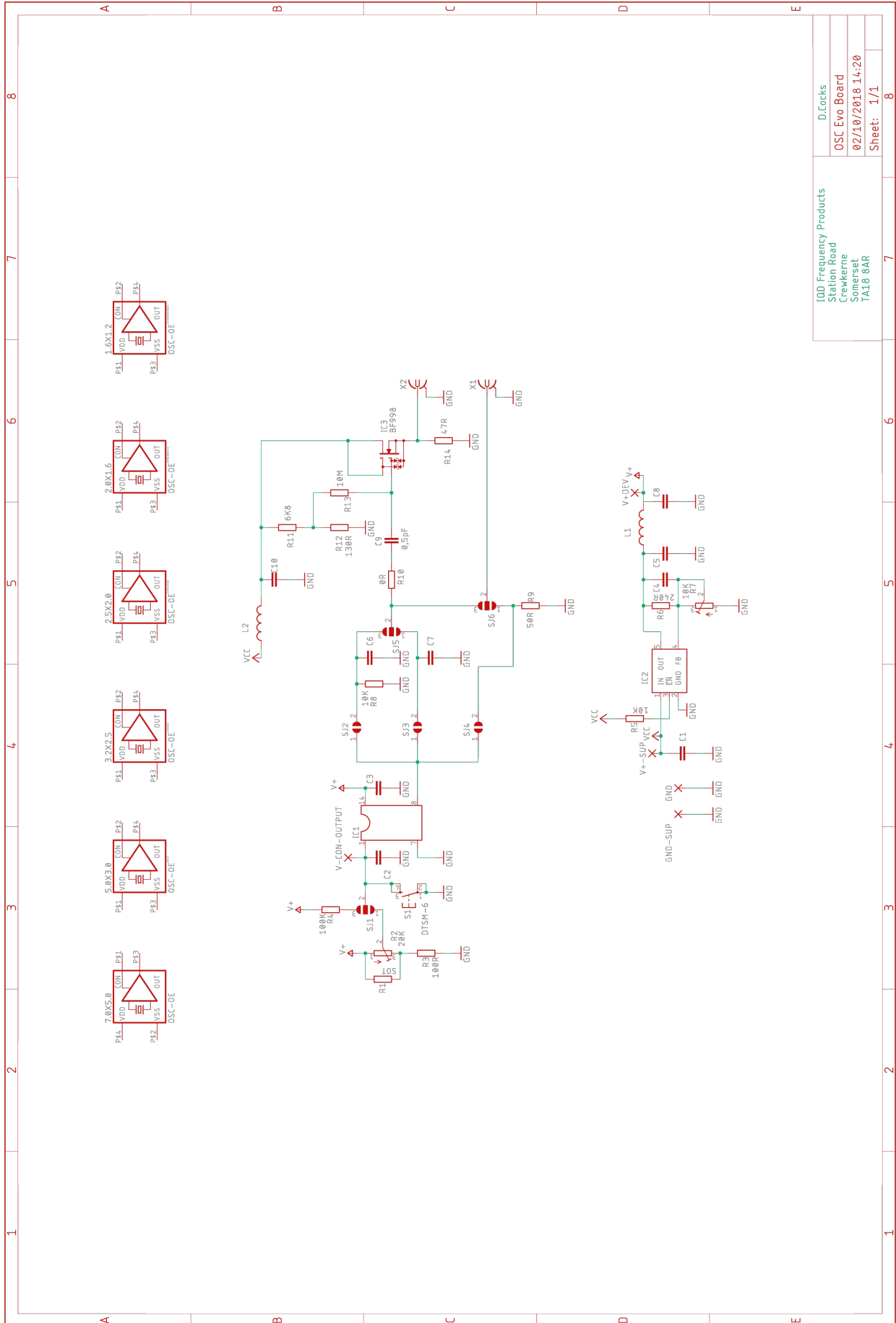

IOQ Frequency Products	D.Cocks
Station Road	OSC Evo Board
Crewkerne	02/10/2018 14:20
TAL8 8AR	Sheet: 1/1





### **IOSC-EVBOARD IMPORTANT NOTICE**

The IOSC-EVBoard was designed to give the best performance over a wide variety of supply voltage levels, output types with frequency types and package types and for use with products including SPXOs with an enable disable function and VCXOs with voltage control function. The board was designed to give both manual control and to allow connection to external inputs for supply and voltage control function. Due to necessary design constraints to allow the above detailed flexibility, the track layout and design is not optimised for any specific oscillator. The IOSC-EVBoard is designed to aid in the evaluation of your oscillator. Following this evaluation it may be possible to optimise the performance of the oscillator by using a PCB designed specifically for the single oscillator under evaluation.

The IOSC-EVBoard being sold or provided by IQD Frequency Products is intended for engineering development or evaluation purposes only and is not for commercial use. As such the IOSC-EVBoard may not be complete in terms of required design, marketing and/or manufacturing related protective considerations, including but not limited to product safety measures typically found in finished commercial goods. As a prototype this product does not fall within the scope of the European Union directive on electromagnetic compatibility and therefore may or may not meet the technical requirements of the directive, or other regulations.

## X-ON Electronics

Largest Supplier of Electrical and Electronic Components

*Click to view similar products for [Clock & Timer Development Tools](#) category:*

*Click to view products by [IQD](#) manufacturer:*

Other Similar products are found below :

[AD9517-0A/PCBZ](#) [AD9517-2A/PCBZ](#) [AD9522-4/PCBZ](#) [AD9520-5PCBZ](#) [AD9553/PCBZ](#) [ADCLK914PCBZ](#) [LMH2180SDEVAL](#) [DSC400-0333Q0032KE1-EVB](#) [TDGL013](#) [MAX2880EVKIT#](#) [MAX2750EVKIT](#) [MAX2752EVKIT](#) [ADCLK946PCBZ](#) [ADCLK946/PCBZ](#) [MAX2622EVKIT](#) [EKIT01-HMC1032LP6G](#) [Si5332-8IX-EVB](#) [RV-2251-C3-EVALUATION-BOARD](#) [Si5332-12IX-EVB](#) [RV-3029-C2-EVALUATION-BOARD-OPTION-B](#) [Si5332-6IX-EVB](#) [SKY72310-11-EVB](#) [EV1HMC8364LP6G](#) [RV-8263-C7-EVALUATION-BOARD](#) [EVK9FGV1002](#) [EVK9FGV1008](#) [EV1HMC6832ALP5L](#) [EVAL01-HMC830LP6GE](#) [EVAL01-HMC911LC4B](#) [TS3002DB](#) [125605-HMC702LP6CE](#) [LMX2487E-EVM](#) [MIKROE-2481](#) [2045](#) [EKIT01-HMC835LP6G](#) [EKIT01-HMC834LP6GE](#) [TS3006DB](#) [DSC-TIMEFLASH2-KIT1](#) [110227-HMC510LP5](#) [110227-HMC513LP5](#) [AD9515/PCBZ](#) [ADCLK948/PCBZ](#) [ADCLK954/PCBZ](#) [112261-HMC739LP4](#) [ADCLK925/PCBZ](#) [AD9522-0/PCBZ](#) [AD9520-4/PCBZ](#) [AC164147](#) [DFR0469](#) [LMK04133EVAL/NOPB](#)