

**Customer Part:**



**Description**

- A GPS disciplined OCXO incorporating a GPS receiver unit to give 1PPS and 10MHz output. With 1.5µs holdover stability achieved by using an adaptive algorithm. Standard NMEA0183 data is available to the user via a serial port.
- Model IQCM-110
- Model Issue number 2

**Frequency Parameters**

- Frequency 10.0MHz
- Operating Temperature Range -20.00 to 75.00°C
- 10MHz RF Output Details, Pin 2:  
 HCMOS Compatible -  
 VoH: 2.7V min  
 VoL: 0.4V max  
 Rise and Fall Time: 8ns max  
 Duty Cycle: 45/55% max  
 Accuracy (24-hour averaging when locked to 1PPS): ±1E-12  
 Short Term Stability (tested after power for 1hr ref to 25°C, 1s, using PN9000 test equipment): 2E-11 max  
 Ageing (Vs and temperature constant, reference to T=25°C, Vs = 5.0V and after 30 days operation): ±0.2ppb per day, ±10ppb per year
- 1PPS Output from internal GPS receiver, Pin 10, Phase Accuracy when locked to GPS:  
 Initial Lock Status (<30mins locked to GPS): ±200ns max  
 Full Lock (>30mins locked to GPS): ±80ns max  
 Steady Lock State (>24hrs GPS lock): 25ns RMS max
- 24hrs Holdover Capability:  
 Reference 7 days powered on, 2 days GPS lock.  
 Temperature varied <1°C/min within operating temperature range.  
 Total Temperature Change Holdover Capability  
 ΔT<±2°C ±1.5µs



**Outline (mm)**

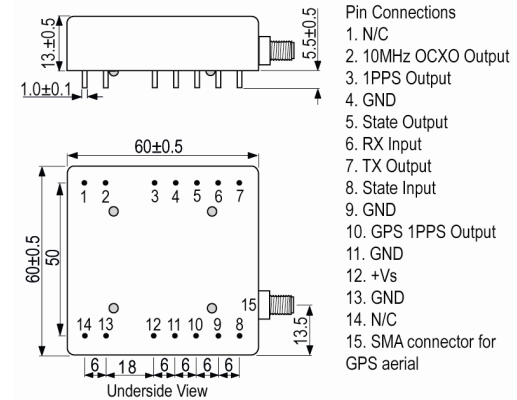

**Workflow Diagram**

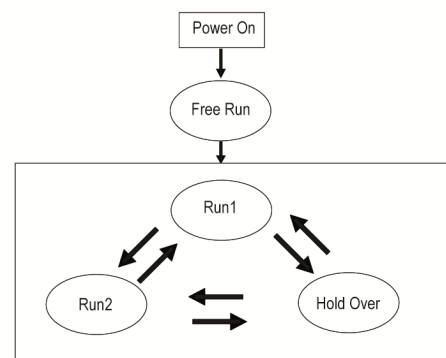

**Sales Office Contact Details:**

UK: +44 (0)1460 270200  
 Germany: 0800 1808 443

France: 0800 901 383  
 USA: +1.760.318.2824

Email: [info@iqdfrequencyproducts.com](mailto:info@iqdfrequencyproducts.com)  
 Web: [www.iqdfrequencyproducts.com](http://www.iqdfrequencyproducts.com)

**Customer Part:****Electrical Parameters**

- Supply Voltage 5.0V ±5%
- Note: Pins 3 to 11 and Pin 13 should not be subjected to a voltage greater 3.6V. If subjected to a higher voltage the processor will be damaged and the unit will not work correctly.
- 1PPS output from internal GPS receiver, Pin 10:  
Waveform: HCMOS  
Test Condition: 15pF  
ViH: 2.7V min  
ViL: 0.4V max  
Pulse Width: 100ms min
- State Input, Pin 8 (<5mA load):  
Lock: 2.7V min  
Unlock: 0.4V max  
Pin 8 has an internal pull-up cct.
- Power Supply Details, Pin 12:  
Supply Voltage: 5.0V ±5%  
Current Consumption: 2A during warm up, 1A steady state @ 25°C  
AC Ripple: 50mV pk-pk max, 10Hz to 1MHz
- GPS Internal Receiver Specification:  
Type: GPS Position Lock  
Number of Channels: 50  
Frequency Band: L1 (1575.42MHz)  
Tracking Code: C/A Code  
Tracking Capability: 12 Satellites  
Sensitivity: Tracking and Navigation 162dBm  
Reacquisition -157dBm  
Cold Start (autonomous) -148dBm  
Antenna Input SMA-KE (active antenna recommended)

**Output Details**

- Output Compatibility HCMOS
- 1PPS Reference Output, Pin 3 (15pF test condition):  
Waveform: HCMOS  
VoH: 2.7V min  
VoL: 0.4V max  
Pulse Width: 100ms min
- Lock Status Indicator, Pin 5:  
Module Locked: 2.7V min  
Module Holdover: 0.4V max  
Module Locked means Working State is = Run2  
Current: 5mA max
- Serial Interface (Pin 6 and Pin 7):  
NMEA-0183  
VoL and ViL: 0.4V max  
VoH and ViH: 2.7V min  
Baud rate: 9600  
Bits: 8  
Parity: N  
Stop Bit: 1

**Noise Parameters**

- Phase Noise on 10MHz RF Output Signal (dBm/Hz):

Offset	Typical	Max
10Hz	-118	-113
100Hz	-138	-133
1kHz	-148	-143
10kHz	-150	-145
100kHz	-150	-145
1MHz	-150	-150

**Sales Office Contact Details:**

UK: +44 (0)1460 270200

France: 0800 901 383

Email: [info@iqdfrequencyproducts.com](mailto:info@iqdfrequencyproducts.com)

Germany: 0800 1808 443

USA: +1.760.318.2824

Web: [www.iqdfrequencyproducts.com](http://www.iqdfrequencyproducts.com)

**Customer Part:****Environmental Parameters**

- Operating Temperature Range: -20 to 75°C
- Storage Conditions:
  - Temperature: -55 to 105°C
  - Humidity: 30 to 80%
- Shock: IEC 68-2-27 Test Ea, Severity 50A: 50G 11ms half sine wave, 3 times in three mutually perpendicular planes.
- Vibration: IEC 68-2-06, Test Fc: 10G, 0.75mm acceleration, 10Hz to 500Hz, 3 times in three mutually perpendicular planes.

**Manufacturing Details**

- ESD Levels: ANSI/ESDA/JEDEC JS-001-2010:
  - Human Body Model, Class 2: 2000V to 4000V
  - Machine Model, Class B: 200V to 400V

**Compliance**

- RoHS Status (2015/863/EU)      Compliant
- REACH Status                      Compliant
- MSL Rating (JDEC-STD-033):      Not Applicable

**Packaging Details**

- Pack Style: Bulk      Loose in bulk pack
  - Pack Size: 1
- *Alternative packing option available*

**Technical Notes**

- *Holdover stability 1.5µs in 24hrs ref ±2°C*

---

**Sales Office Contact Details:**

UK: +44 (0)1460 270200  
Germany: 0800 1808 443

France: 0800 901 383  
USA: +1.760.318.2824

Email: [info@iqdfrequencyproducts.com](mailto:info@iqdfrequencyproducts.com)  
Web: [www.iqdfrequencyproducts.com](http://www.iqdfrequencyproducts.com)

## X-ON Electronics

Largest Supplier of Electrical and Electronic Components

*Click to view similar products for [OCXO Oscillators](#) category:*

*Click to view products by [IQD](#) manufacturer:*

Other Similar products are found below :

[AOCTQ5-V-10.000MHz-I3-SW](#) [AOCTQ5-X-10.000MHz-M10-SW](#) [AOCTQ5-V-10.000MHz-I5](#) [AOCTQ5-X-10.000MHz-I3-SW](#) [AOCTQ5-V-10.000MHz-M10](#) [OX-221-9100-20M000](#) [OX-221-9102-49M152](#) [SIT8102AC12-33E-98.30400Y](#) [8208AI23-33E26.000](#) [ECOC-2522-40.000-3GS](#) [AOCJY2A-10.000MHz-F-SW](#) [AOCJY3B-10.000MHz-E-SW](#) [AOCJY4A-10.000MHz-SW](#) [AOCJY3-10.000MHz-E-SW](#) [AOC1409VAUC-20.0000C](#) [AOC1409XAUC-20.0000C](#) [AOC2012VAJC-25.0000C](#) [AOC2012XAJC-10.0000C](#) [AOC2012XAJC-12.8000C](#) [AOC2012XAJC-19.4400C](#) [AOC2012XAJC-25.0000C](#) [AOC2522BVAUC-20.0000](#) [AOC2522BVAUC-12.8000](#) [AOC2522BVAUC-38.8800](#) [AOCJY-100.000MHZ](#) [AOCJY-100.000MHz-E](#) [AOCJY-100.000MHz-F](#) [AOCJY1-100.000MHz](#) [AOCJY1-10.000MHZ](#) [AOCJY1-10.000MHz-E-SW](#) [AOCJY1A-100.000MHz](#) [AOCJY1A-10.000MHz](#) [AOCJY-20.000MHz](#) [AOCJY-20.000MHZ-F](#) [AOCJY2-10.000MHz](#) [AOCJY2-10.000MHZ-E](#) [AOCJY2-100.000MHZ-E](#) [AOCJY3-10.000MHz](#) [AOCJY-38.880MHz](#) [AOCJY3B-10.000MHz](#) [AOCJY3B-10.000MHz-E](#) [AOCJY4B-10.000MHz-SW](#) [AOCJY5-10.000MHz](#) [AOCJY6-10.000MHz-1](#) [AOCJY7TQ-X-100.000MHz-1](#) [AOCJYR-10.000MHz-M5625LF](#) [AOCJY1A-100.000MHZ-E](#) [AOCJY2-10.000MHZ-E-SW](#) [AOCJY-38.880MHZ-E](#) [AOCJY3A-100.000MHZ-F](#)