

# IS31AP2005 CLASS-D AUDIO AMPLIFIER

## DESCRIPTION

The IS31AP2005 demo board is a fully assembled and tested PCB that uses the IS31AP2005 Class-D power amplifier to drive an 8Ω or 4Ω speaker in portable audio applications. Designed to operate from a 2.7V to 5.5V DC power supply, the demo board accepts a single-ended or differential input signal. The demo board provides a BTL output capable of delivering 2.6W into a 4Ω speaker at 5V.

## FEATURES

- Supply voltage range from 2.7V to 5.5V
- Delivers 2.6W into a 4Ω speaker at 5V supply (THD+N=10%)
- Delivers 1.8W into an 8Ω speaker at 5V supply (THD+N=10%)
- Available in MSOP-8 and DFN-8 packages

## QUICK START

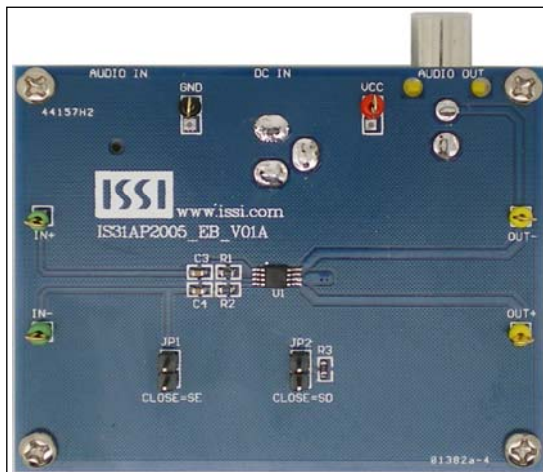

Figure 1: Photo of IS31AP2005 Evaluation Board

## RECOMMENDED EQUIPMENT

- 5.0V, 2A power supply
- Audio source (i.e. MP3 player, Notebook PC, etc.)
- 8Ω or 4Ω speaker

## ABSOLUTE MAXIMUM RATINGS

- ≤ 5.5V power supply

**Caution: Do not exceed the conditions listed above; otherwise the board will be damaged.**

## PROCEDURE

The IS31AP2005 demo board is fully assembled and tested. Follow the steps listed below to verify board operation.

**Caution: Do not turn on the power supply until all connections are completed.**

- 1) Connect a 4Ω (or larger) speaker across the OUT- terminal and OUT+ terminal.
- 2) Connect the ground terminal of the power supply to the GND and the positive terminal to the VCC. Or connect DC power to connector (DC IN).
- 3) If the audio source is differential, remove jumper JP1, connect the negative of the audio source to the IN- terminal, and connect the positive of the audio source to IN+ terminal.
- 4) If the audio source is single-ended, connect the audio source to the IN+ terminal, and close jumper JP1; or connect audio source to the audio connector (AUDIO IN) and close jumper JP1.
- 5) Turn on the power supply.
- 6) Turn on the audio source.

## ORDERING INFORMATION

Part No.	Temperature Range	Package
IS31AP2005-SLS2-EB	-40°C ~ +85°C (Industrial)	MSOP-8, Lead-free

Table 1: Ordering Information

**For pricing, delivery, and ordering information, please contact ISSI's analog marketing team at [analog@issi.com](mailto:analog@issi.com) or (408) 969-6600.**

## IS31AP2005 CLASS-D AUDIO AMPLIFIER

### DETAILED DESCRIPTION

The IS31AP2005 demo board features the IS31AP2005 Class-D power amplifier IC, designed to drive speaker impedance of 4Ω or larger.

### CUSTOMIZING THE GAIN

The IS31AP2005 demo board is shipped with a gain of 18.4dB and is set by resistors  $R_1$  ( $R_1$ ,  $R_2$ ). Change resistors  $R_1$  and  $R_2$  to reconfigure the gain of the board. Gain determined in Equation (1) and refer to IS31AP2005 data sheet for more detail.

$$Gain = \frac{2 \times 150k\Omega}{R_1} \left( \frac{V}{V} \right) \quad (1)$$

### HIGH-PASS FILTER

The input capacitors  $C_1$  ( $C_3$ ,  $C_4$ ) and input resistors  $R_1$  ( $R_1$ ,  $R_2$ ) form a high-pass filter with the corner frequency,  $f_c$  determined in Equation (2).

$$f_c = \frac{1}{(2\pi R_1 C_1)} \quad (2)$$

### SHUTDOWN MODE

Jumper (JP2) controls the shutdown pin of the IS31AP2005 IC. Connect the shunt across pin 1 and 2 of the jumper (JP2) to enter the shutdown mode of the board.

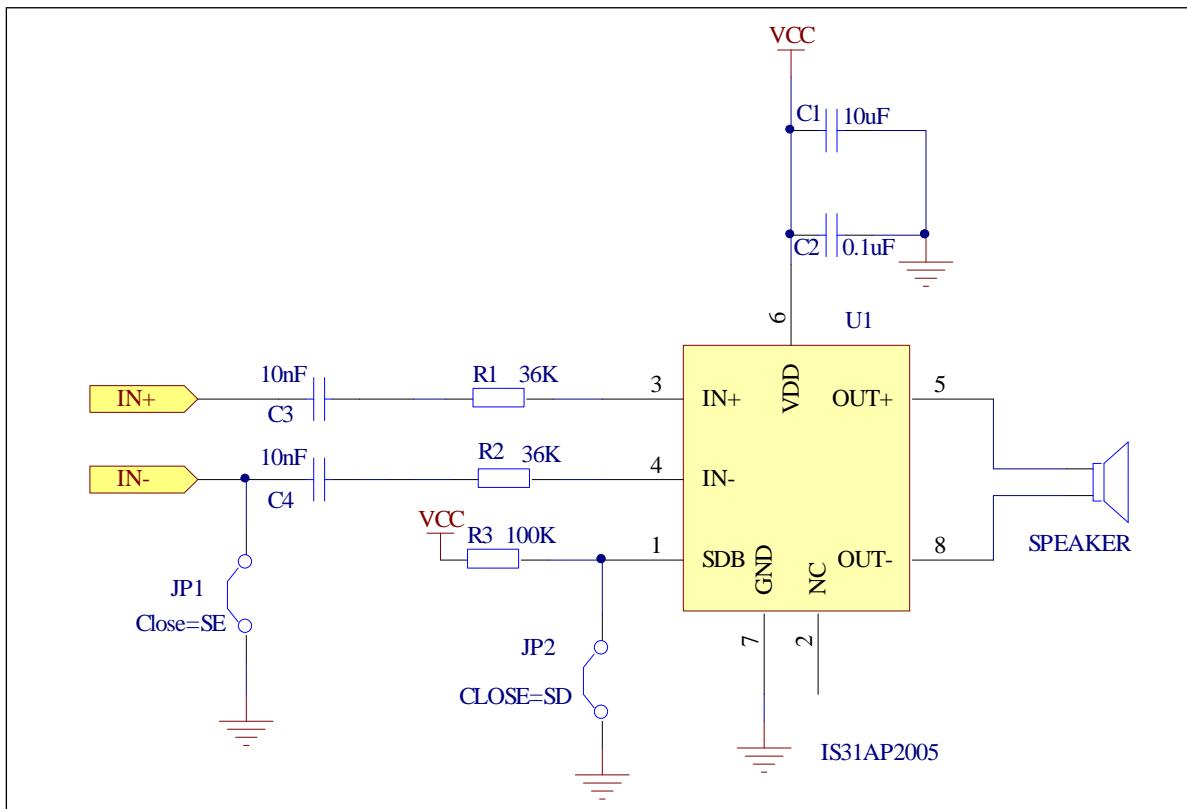

Figure 2: IS31AP2005 Application Circuit



## IS31AP2005 CLASS-D AUDIO AMPLIFIER

### BILL OF MATERIALS

Name	Symbol	Description	Qty	Supplier	Part No.
Amplifier	U1	Class- D power amplifier	1	ISSI	IS31AP2005
Resistor	R1,R2	RES,36k,1/16W,±1%,SMD	2	Yageo	RC0603FR-0720KL
Resistor	R3	RES,100k,1/16W,±5%,SMD	1	Yageo	RC0603JR-07100KL
Capacitor	C1	CAP,10µF,10V,±20%,SMD	1	Yageo	CC0805KKX7R6BB106
Capacitor	C2	CAP,0.1µF,50V,±10%,SMD	1	Yageo	CC0603KKX7R9BB104
Capacitor	C3,C4	CAP,0.1µF,50V,±10%,SMD	2	Yageo	CC0603KKX7R9BB104
Connector	DC IN	2.5mm DC connector	1		
Connector	AUDIO OUT	RCA –type connector	1		
Connector	AUDIO IN	3.5mm min connector	1		

*Bill of materials, refer to Figure 2 above.*

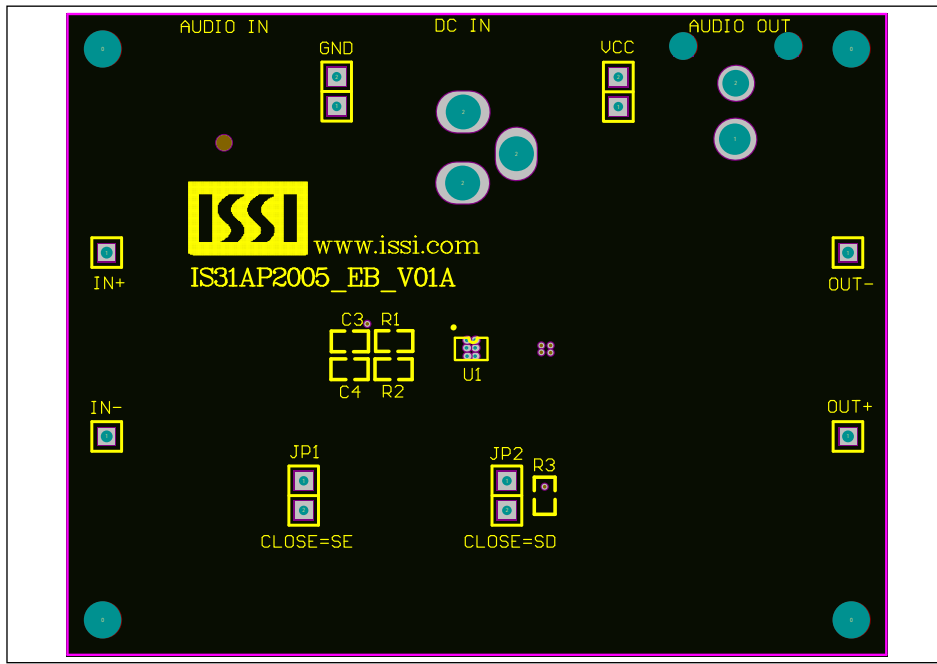

**Figure 3: Board Component Placement Guide - Top Layer**

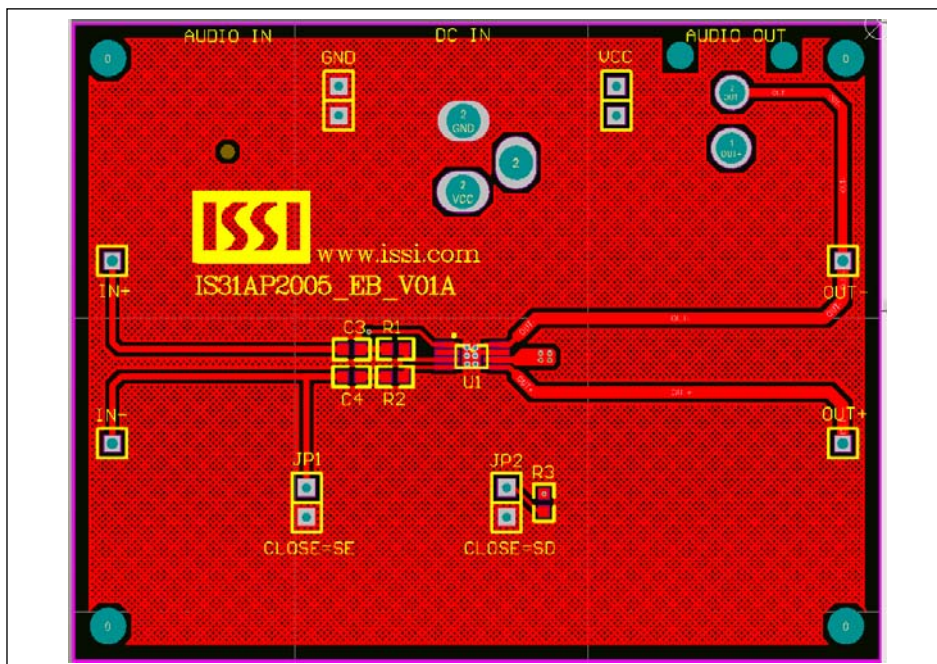

**Figure 4: Board PCB Layout - Top Layer**

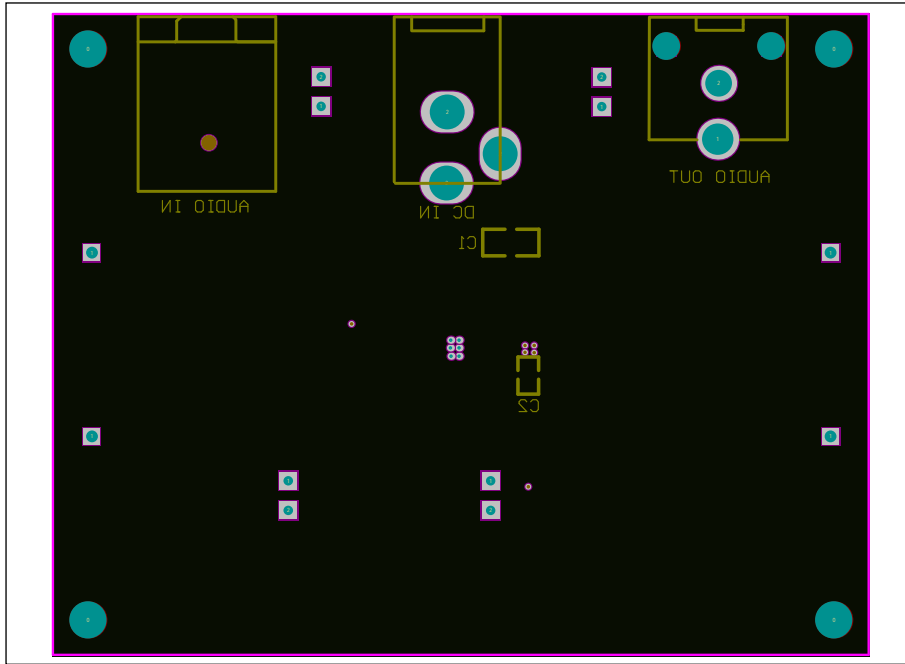

Figure 5: Board Component Placement Guide - Bottom Layer

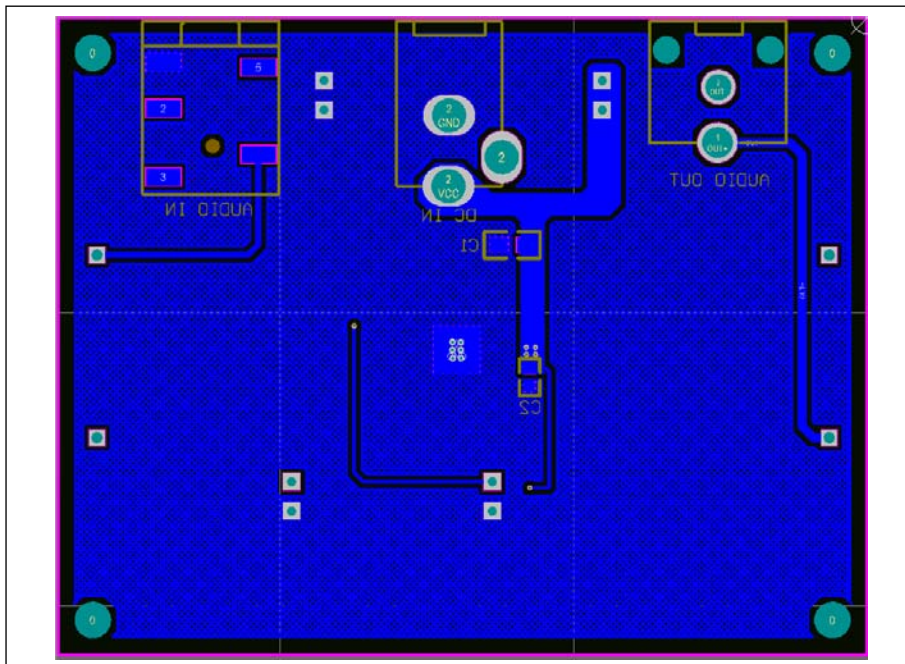

Figure 6: Board PCB Layout - Bottom Layer

Copyright © 2015 Integrated Silicon Solution, Inc. All rights reserved. ISSI reserves the right to make changes to this specification and its products at any time without notice. ISSI assumes no liability arising out of the application or use of any information, products or services described herein. Customers are advised to obtain the latest version of this device specification before relying on any published information and before placing orders for products. Integrated Silicon Solution, Inc. does not recommend the use of any of its products in life support applications where the failure or malfunction of the product can reasonably be expected to cause failure of the life support system or to significantly affect its safety or effectiveness. Products are not authorized for use in such applications unless Integrated Silicon Solution, Inc. receives written assurance to its satisfaction, that:

- a.) the risk of injury or damage has been minimized;
- b.) the user assume all such risks; and
- c.) potential liability of Integrated Silicon Solution, Inc is adequately protected under the circumstances

## X-ON Electronics

Largest Supplier of Electrical and Electronic Components

*Click to view similar products for [Audio IC Development Tools](#) category:*

*Click to view products by [ISSI](#) manufacturer:*

Other Similar products are found below :

[1580/5171-DEMO](#) [LM4935RLEVAL](#) [LM4923LQBD](#) [MAX9738EVKIT+](#) [EVAL-ADAV803EBZ](#) [CDBWM8725-M-1](#) [CDBWM8533-M-1](#)  
[EV\\_ICS-40740-FX](#) [SDCK3](#) [PIM524](#) [DEV-17737](#) [EVALAHNBIM69D130V01TOBO1](#) [1063](#) [MIKROE-2454](#) [1381](#) [MIKROE-2477](#) [1712](#)  
[175](#) [1788](#) [PGA2505EVM](#) [LM4780TABD/NOPB](#) [2130](#) [2220](#) [EVAL-ADAU1442EBZ](#) [AD8273-EVALZ](#) [2341](#) [2342](#) [TPA2100P1EVM](#)  
[TPA203XD1EVM](#) [TPA2031D1EVM](#) [TPA2014D1EVM](#) [TPA2006D1EVM](#) [DEM-PCM2912AEVM](#) [TLV320AIC3204EVM-K](#)  
[TLV320AIC3120EVM-U](#) [TLV320AIC3106EVM-K](#) [TLV320AIC3101EVM-K](#) [2716](#) [DFR0064](#) [DFR0119](#) [DFR0273](#) [SEN-14262](#) [3357](#)  
[EV\\_ICS-40619-FX](#) [ASD2841-R](#) [EV\\_ICS-43434-FX](#) [DEV-10587](#) [3346](#) [EV\\_ICS-40618-FX](#) [GSK-118](#)