

IS31AP4991 CLASS-AB AUDIO AMPLIFIER

DESCRIPTION

The IS31AP4991 demo board is a fully assembled and tested PCB that uses the IS31AP4991 Class-AB power amplifier to drive an 8Ω or larger speaker in portable audio applications. The demo board accepts a single-ended input signal. The demo board provides a BTL output capable of delivering 1.2W into an 8Ω speaker at 5V.

FEATURES

- Supply voltage range from 2.7V to 5.5V
- Delivers 1.2W into an 8Ω speaker at 5V supply. (THD+N=10%).
- Ultra-low distortion (0.025%@0.5W, 1kHz)
- Available in MSOP-8 and SOP-8 package

QUICK START

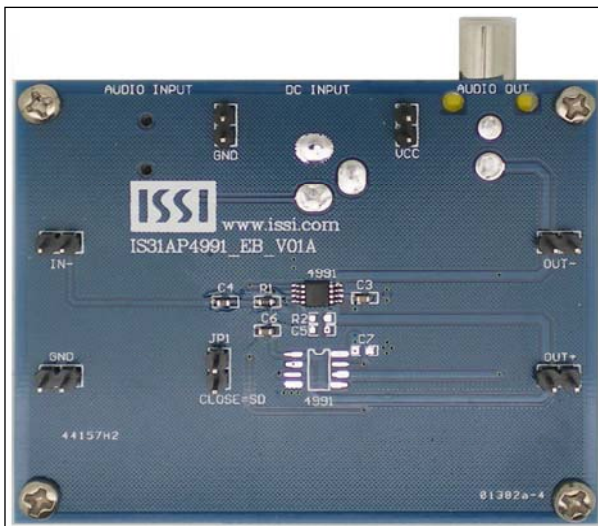

Figure 1: Photo of IS31AP4991 Evaluation Board

Note: Only one IC type will be installed on PCB.

RECOMMENDED EQUIPMENT

- 5.0V, 2A power supply
- Audio source (i.e. MP3 player, Notebook PC, etc.)
- 8Ω speaker

ABSOLUTE MAXIMUM RATINGS

- ≤ 5.5V power supply

Caution: Do not exceed the conditions listed above; otherwise the board will be damaged.

PROCEDURE

The IS31AP4991 demo board is fully assembled and tested. Follow the steps listed below to verify board operation.

Caution: Do not turn on the power supply until all connections are completed.

- 1) Connect an 8Ω (or larger) speaker across the OUT- terminal and OUT+ terminal. Or connect speaker to the connector (AUDIO OUT).
- 2) Connect the ground terminal of the power supply to the GND and the positive terminal to the VCC. Or connect DC power to connector (DC INPUT).
- 3) Connect the audio source to the IN- terminal; or connect audio source to the connector (AUDIO INPUT).
- 4) Turn on the power supply.
- 5) Turn on the audio source.

ORDERING INFORMATION

Part No.	Temperature Range	Package
IS31AP4991-GRLS2-EB IS31AP4991-SLS2-EB	-40°C ~ +85°C (Industrial)	SOP-8, Lead-free MSOP-8, Lead-free

Table 1: Ordering Information

For pricing, delivery, and ordering information, please contact Lumissil's analog marketing team at analog@Lumissil.com or (408) 969-6600.

IS31AP4991 CLASS-AB AUDIO AMPLIFIER

DETAILED DESCRIPTION

The IS31AP4991 demo board features the IS31AP4991 Class-AB power amplifier IC, designed to drive speaker impedance of 8Ω or larger.

CUSTOMIZING THE GAIN

The IS31AP4991 demo board is shipped with a gain of 18.3dB and is set by resistors R_I (R₁) and R_F (R₂). Change resistors R_I and R_F to reconfigure the gain of the board and gain determined in Equation (1)

$$Gain = \frac{2 \times R_F}{R_I} \left(\frac{V}{V} \right) \quad (1)$$

HIGH-PASS FILTER

The input capacitor C₁ (C₄) and input resistor R₁ (R₁) form a high-pass filter with the corner frequency, f_c, determined in Equation (2) and refer to IS31AP4991 data sheet for more detail.

$$f_c = \frac{1}{(2\pi R_I C_I)} \quad (2)$$

SHUTDOWN MODE

Jumper (JP1) controls the shutdown pin of the IS31AP4991 IC. Connect the shunt across pin 1 and 2 of the jumper (JP1) to enter the shutdown mode of the board.

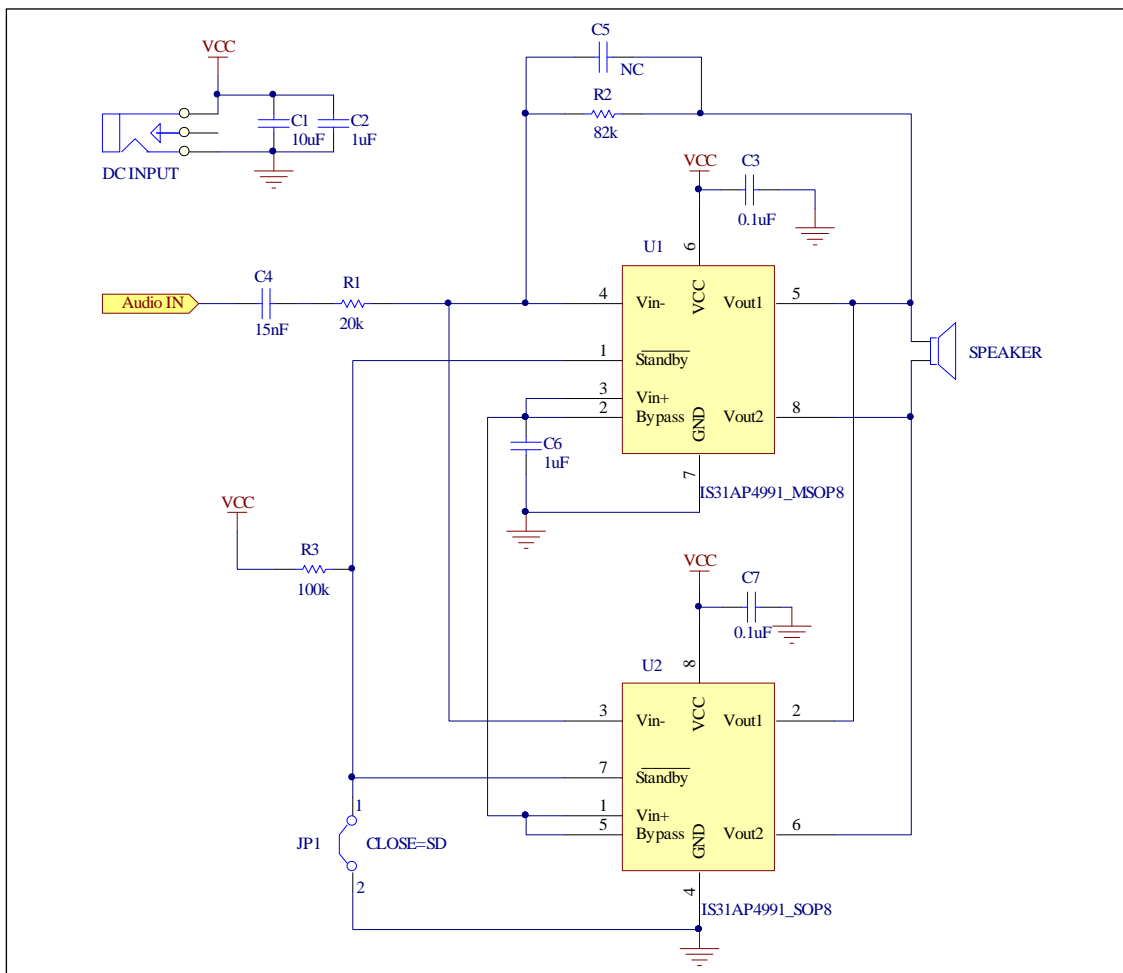

Figure 2: IS31AP4991 Application Circuit

IS31AP4991 CLASS-AB AUDIO AMPLIFIER

BILL OF MATERIALS

Name	Symbol	Description	Qty	Supplier	Part No.
Amplifier	U1	Class- AB power amplifier	1	Lumissil	IS31AP4991
Resistor	R1	RES,20k, 1/16W,±1%,SMD	1	Yageo	RC0603FR-0720KL
Resistor	R2	RES,82k, 1/16W,±1%,SMD	1	Yageo	RC0603FR-0782KL
Resistor	R3	RES,100k, 1/16W,±5%,SMD	1	Yageo	RC0603JR-07100KL
Capacitor	C1	CAP,10µF,10V,±20%,SMD	1	Yageo	CC0805KKX7R6BB106
Capacitor	C2,C6	CAP, 1µF,50V,±10%,SMD	2	Yageo	CC0603KKX7R9BB105
Capacitor	C3,C7	CAP,0.1µF,50V,±10%,SMD	2	Yageo	CC0603KKX7R9BB104
Capacitor	C4	CAP,15nF,50V,±10%,SMD	1	Yageo	CC0603KKX7R9BB153
Connector	DC INPUT	2.5mm DC connector	1		
Connector	AUDIO OUT	RCA –type connector	1		
Connector	AUDIO INPUT	3.5mm min connector	1		
	U2,C5	No installed			

Bill of materials, refers to Figure 2 above.

IS31AP4991 CLASS-AB AUDIO AMPLIFIER

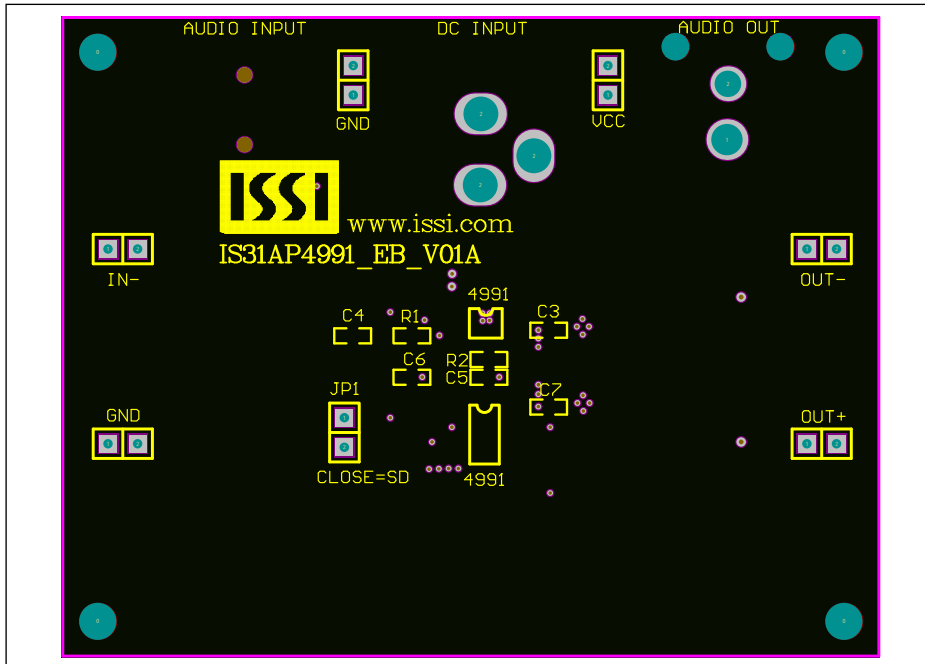

Figure 2: Board Component Placement Guide - Top Layer

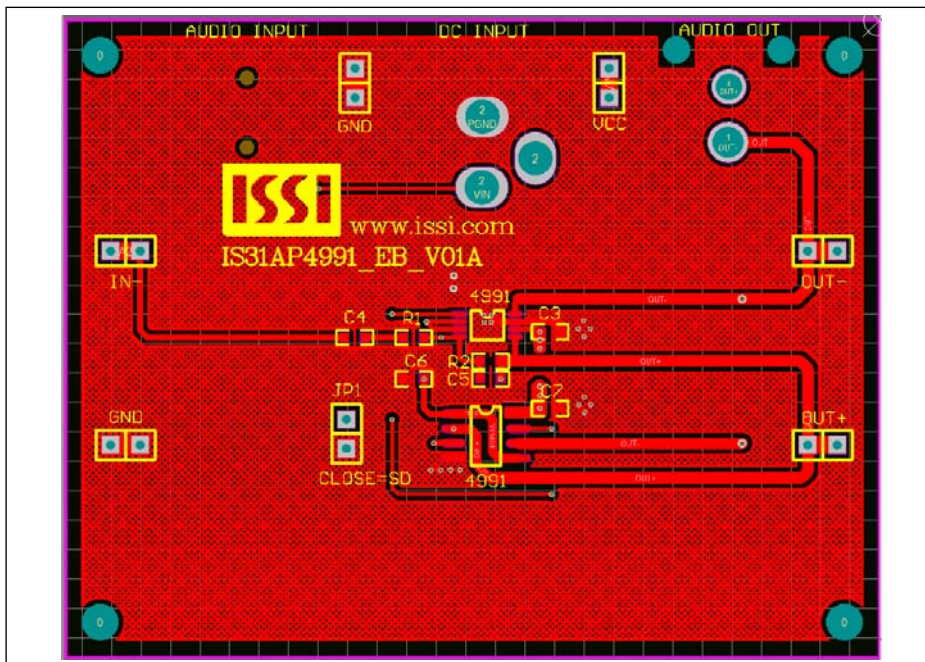

Figure 3: Board PCB Layout - Top Layer

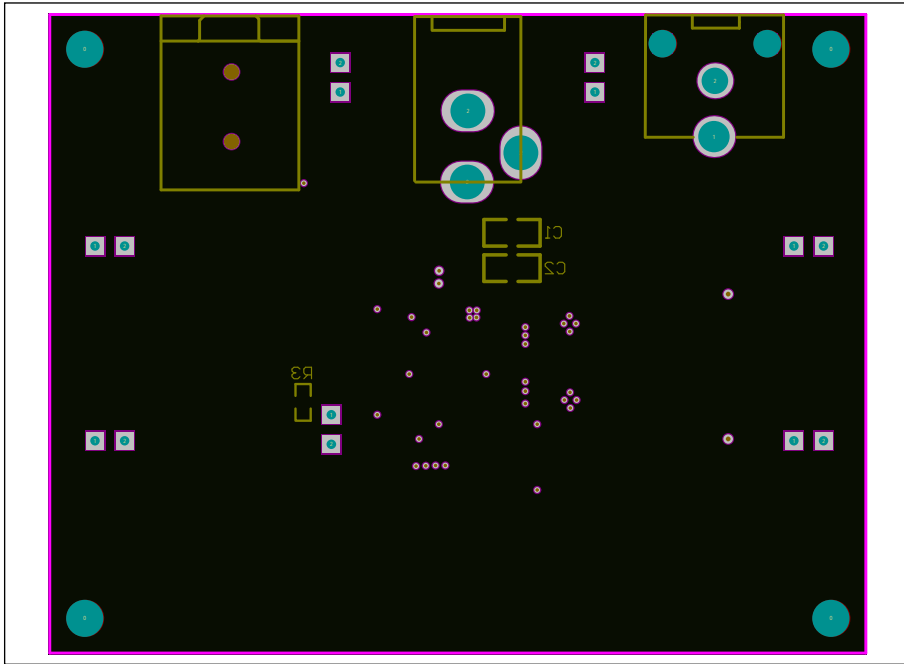

Figure 4: Board Component Placement Guide - Bottom Layer

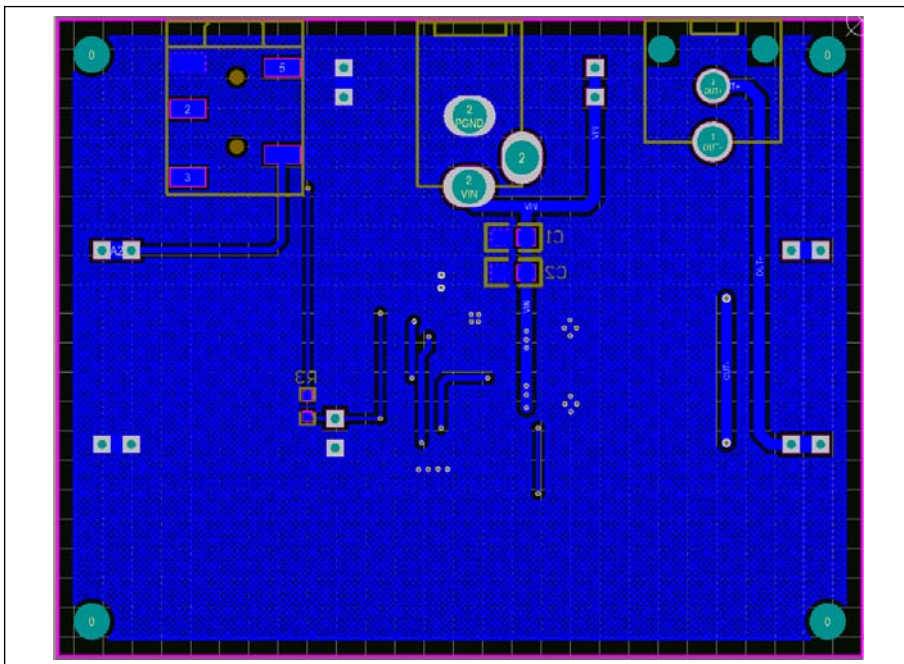

Figure 5: Board PCB Layout - Bottom Layer

Copyright © 2015 Lumissil Microsystems. All rights reserved. Lumissil Microsystems reserves the right to make changes to this specification and its products at any time without notice. Lumissil Microsystems assumes no liability arising out of the application or use of any information, products or services described herein. Customers are advised to obtain the latest version of this device specification before relying on any published information and before placing orders for products.

Lumissil Microsystems does not recommend the use of any of its products in life support applications where the failure or malfunction of the product can reasonably be expected to cause failure of the life support system or to significantly affect its safety or effectiveness. Products are not authorized for use in such applications unless Lumissil Microsystems receives written assurance to its satisfaction, that:

- a.) the risk of injury or damage has been minimized;
- b.) the user assume all such risks; and
- c.) potential liability of Lumissil Microsystems is adequately protected under the circumstances

X-ON Electronics

Largest Supplier of Electrical and Electronic Components

Click to view similar products for [Amplifier IC Development Tools](#) category:

Click to view products by [ISSI](#) manufacturer:

Other Similar products are found below :

[EVAL-ADCMP566BCPZ](#) [EVAL-ADCMP606BKSZ](#) [AD8013AR-14-EBZ](#) [AD8033AKS-EBZ](#) [AD8044AR-EBZ](#) [AD8225-EVALZ](#)
[ADA4859-3ACP-EBZ](#) [ADA4862-3YR-EBZ](#) [DEM-OPA-SO-2B](#) [OPA653EVM](#) [AD744JR-EBZ](#) [AD8023AR-EBZ](#) [AD8030ARJ-EBZ](#)
[AD8040ARU-EBZ](#) [AD8073JR-EBZ](#) [AD813AR-14-EBZ](#) [AD848JR-EBZ](#) [ADA4858-3ACP-EBZ](#) [ADA4922-1ACP-EBZ](#) [551600075-](#)
[001/NOPB](#) [DEM-OPA-SO-2E](#) [THS7374EVM](#) [EVAL-ADCMP553BRMZ](#) [EVAL-ADCMP608BKSZ](#) [MIOP 42109](#) [EVAL-ADCMP600BKSZ](#)
[EVAL-ADCMP609BRMZ](#) [ADA4950-1YCP-EBZ](#) [MAX9928EVKIT+](#) [MAX9611EVKIT](#) [MAX9937EVKIT+](#) [MAX9934TEVKIT+](#)
[MAX44290EVKIT#](#) [MAX2644EVKIT](#) [MAX2634EVKIT](#) [DEM-OPA-MSOP-2A](#) [AD8139ACP-EBZ](#) [MAX4073EVKIT+](#) [DEM-OPA-SO-2C](#)
[MAX2643EVKIT](#) [ISL28158EVAL1Z](#) [MAX40003EVKIT#](#) [MAX2470EVKIT](#) [MAX2473EVKIT](#) [MAX2472EVKIT](#) [MAX4223EVKIT](#)
[MAX9700BEVKIT](#) [DC2473A](#) [MADL-011014-001SMB](#) [DC1685A](#)