

# IS31BL3212

## FOUR CHANNEL CONSTANT CURRENT LED DRIVER

June 2014

### GENERAL DESCRIPTION

The IS31BL3212 provides four regulated current sources, delivers up to 23mA of load current to accommodate four white LEDs. It requires no charge pump, has no noise and significantly improved the efficiency.

The serial digital input is used to enable, disable, and set current for each LED with 16 settings down to 0.69mA. A low-current shutdown feature disconnects the load from the input and reduces quiescent current typically 1.0mA.

The IS31BL3212 is available in a Pb-free, space-saving 2mm×2mm DFN-8 and SOT23-6 package.

### FEATURES

- Ultra low headroom voltage
- Cost effective LED driver
- Four channel constant current output ideal for driving LEDs
- Best noise and efficiency performance
- Ultra low quiescent supply current: 1.0mA (Typ.)
- Highly integrated design, minimal component
- Low shutdown current: 1.0µA (Typ.)

### APPLICATIONS

- White LED display backlights
- White LED keypad backlights
- Cell Li-ion battery-operated equipment including PDAs, hand-held PCs, cellular phone

### TYPICAL APPLICATION CIRCUIT

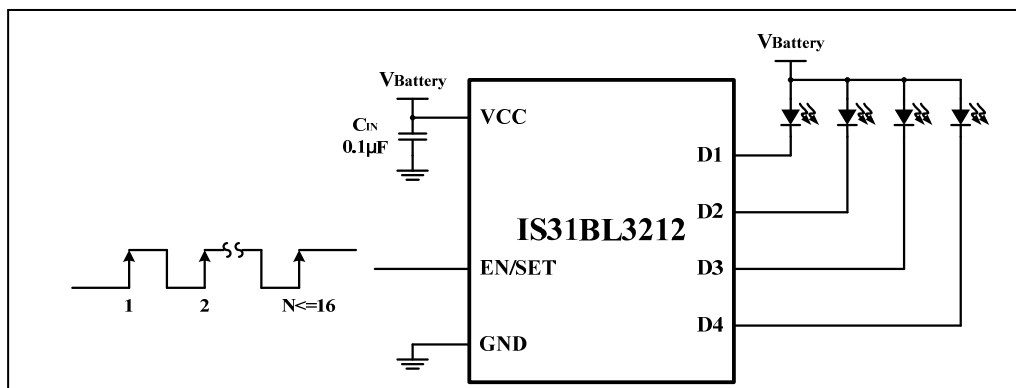

Figure 1 Typical Application Circuit

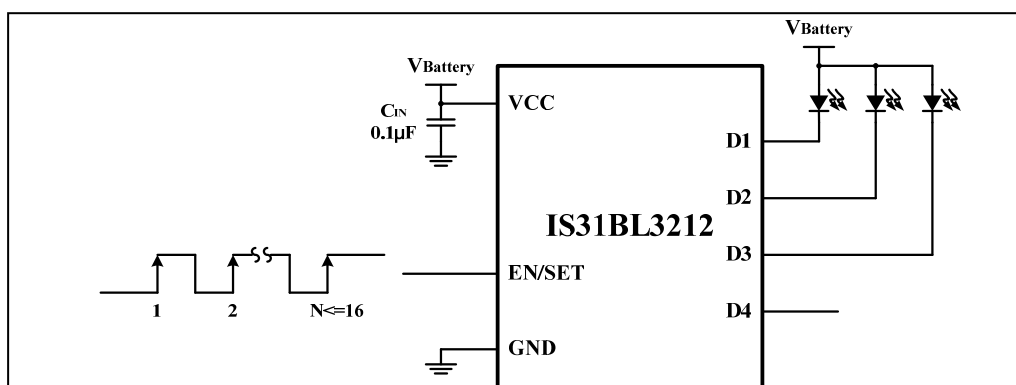
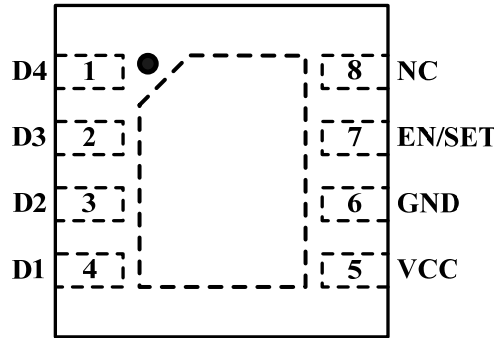
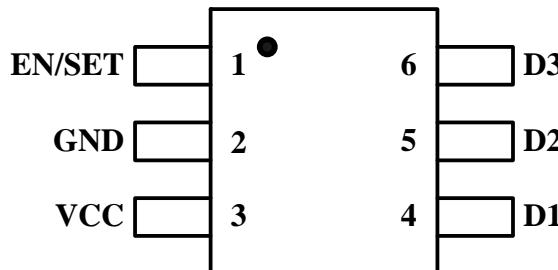

Figure 2 Application Circuit for Less Than 4 LEDs

**Note:** If less than four LEDs connected, the left pin can be floating or connected to GND. Connecting to GND is recommended.

# IS31BL3212

## PIN CONFIGURATION

Package	Pin Configuration (Top View)
DFN-8	
SOT23-6	

## PIN DESCRIPTION

No.		Pin	Description
DFN-8	SOT23-6		
1	-	D4	White LED channel.
2~4	6~4	D3~D1	White LED channel.
5	3	VCC	Power supply input.
6	2	GND	Ground.
7	1	EN/SET	Serial digital input, control the output current. Internal 500kΩ pull down resistor.
8	-	NC	No connection.
	-	Thermal Pad	Connect to GND.

# IS31BL3212

## ORDERING INFORMATION

Industrial Range: -40°C to +85°C

Order Part No.	Package	QTY/Reel
IS31BL3212-DLS2-TR	DFN-8, Lead-free	3000
IS31BL3212-STLS2-TR	SOT23-6, Lead-free	

Copyright © 2014 Lumissil Microsystems. All rights reserved. Lumissil Microsystems reserves the right to make changes to this specification and its products at any time without notice. Lumissil Microsystems assumes no liability arising out of the application or use of any information, products or services described herein. Customers are advised to obtain the latest version of this device specification before relying on any published information and before placing orders for products.

Lumissil Microsystems does not recommend the use of any of its products in life support applications where the failure or malfunction of the product can reasonably be expected to cause failure of the life support system or to significantly affect its safety or effectiveness. Products are not authorized for use in such applications unless Lumissil Microsystems receives written assurance to its satisfaction, that:

- a.) the risk of injury or damage has been minimized;
- b.) the user assume all such risks; and
- c.) potential liability of Lumissil Microsystems is adequately protected under the circumstances

# IS31BL3212

## ABSOLUTE MAXIMUM RATINGS

Supply voltage, $V_{CC}$	-0.3V ~ +6.0V
EN/SET voltage to GND, $V_{EN/SET}$	-0.3V ~ $V_{CC}+0.3V$
Maximum junction temperature, $T_{JMAX}$	+150°C
Storage temperature range, $T_{STG}$	-65°C ~ +150°C
Operating temperature range, $T_A$	-40°C ~ +85°C
ESD (HBM)	±3kV
ESD (CDM)	±1kV

**Note:** Stresses beyond those listed under "Absolute Maximum Ratings" may cause permanent damage to the device. These are stress ratings only and functional operation of the device at these or any other condition beyond those indicated in the operational sections of the specifications is not implied. Exposure to absolute maximum rating conditions for extended periods may affect device reliability.

## ELECTRICAL CHARACTERISTICS

$T_A = 25^\circ\text{C}$ , unless otherwise noted. Typical values are  $T_A = 25^\circ\text{C}$ ,  $V_{CC} = 3.6V$ . (Note 1)

Symbol	Parameter	Condition	Min.	Typ.	Max.	Unit
<b>Input Power Supply</b>						
$V_{CC}$	Operation range		2.7		5.5	V
$I_{IN}$	Operating current	$3.0 \leq V_{CC} \leq 5.5$ , active no load, current data = 1 (Note 2)		1.0		mA
$I_{SHDN}$	Shutdown current	$V_{EN/SET} = 0V$		1.0	2.6	μA
$V_{HR}$	Minimum headroom voltage (DX)	$I_{DX} = 15mA$ , $V_{CC} = 3.3V$		49		mV
$V_{HR}$	Minimum headroom voltage (DX)	$I_{DX} = 20mA$ , $V_{CC} = 3.3V$		60		mV
$I_{DX}$	Output current regulation	Data = 1 (Note 2)		23		mA
<b>EN/SET</b>						
$V_{EN/SET(L)}$	Enable threshold low	$V_{CC} = 2.7V$			0.4	V
$V_{EN/SET(H)}$	Enable threshold high	$V_{CC} = 5.5V$	1.4			V
$t_{EN/SET LO}$	EN/SET low time		0.3		75	μs
$t_{EN/SET HI MIN}$	Minimum EN/SET high time	(Note 3)	1.0			μs
$t_{EN/SET HI MAX}$	Maximum EN/SET high time	(Note 3)			92	μs
$t_{OFF}$	EN/SET off timeout		500			μs
$t_{LAT}$	EN/SET latch timeout		500			μs
$R_{EN/SET DOWN}$	EN/SET pull down resistor	(Note 3)		500		kΩ

**Note 1:** The IS31BL3212 is production tested at room temperature but guaranteed to meet performance specifications over other temperature range by design, characterization, and correlation with statistical process controls.

**Note 2:** See PCC wire Serial Interface section in application information for more.

**Note 3:** Guaranteed by design.

# IS31BL3212

## FUNCTIONAL BLOCK DIAGRAM

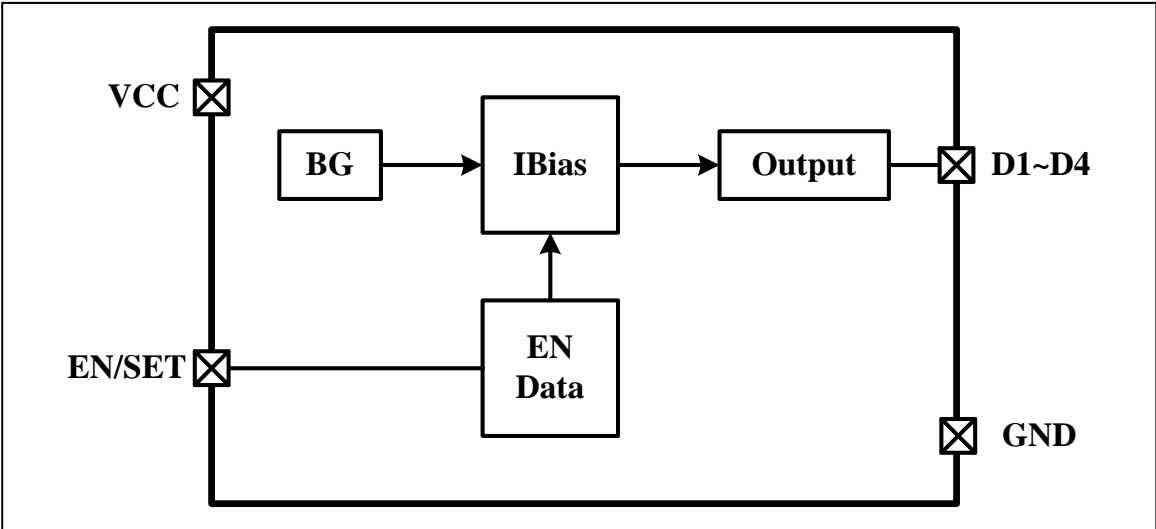

# IS31BL3212

## APPLICATION INFORMATION

### OUTPUT CURRENT CAPABILITY

In order for the output currents to be regulated properly, sufficient headroom voltage ( $V_{HR}$ ) is required. The headroom voltage refers to the minimum amount of voltage that must be present across the current source in order to ensure the desired current is realizable. To ensure the desired current is obtained, apply the following equations to find the minimum input voltage required:

$$V_{CC} - V_{LEDX} \geq V_{HR}$$

Notice that if less than four LEDs connected, the left pin can be floating or connected to GND.

### FUNCTIONAL DESCRIPTION

The four constant current source outputs (D1 to D4) can drive four individual LEDs with a maximum current of 23mA each. The PCC wire serial interface enables the IS31BL3212 and sets the current source magnitudes.

### CONSTANT CURRENT OUTPUT LEVEL SETTINGS

The constant current source levels for D1 to D4 are set via the serial interface according to a logarithmic scale. For the whole 16 codes, each code is approximately 1.5dB lower than the previous code. In this manner, LED brightness appears linear with each increasing code count. Because the outputs D1 to D4 are true independent constant current sources, the voltage observed on any single given output will be determined by the actual forward voltage ( $V_F$ ) for the LED being driven.

Since the output current sources of the IS31BL3212 are programmable, no PWM (pulse width modulation) or additional control circuitry is needed to control LED brightness. This feature greatly reduces the burden on a microcontroller or system IC to manage LED or display brightness, allowing the user to "set it and forget it." With its high-speed serial interface (1MHz data rate), the output current of the IS31BL3212 can be changed successively to brighten or dim LEDs, in

smooth transitions (e.g., to fade-out) or in abrupt steps, giving the user complete programmability and real-time control of LED brightness.

### PCC WIRE SERIAL INTERFACE

The current level magnitude is controlled by Pulse Count Control (PCC wire) serial interface. The interface records rising edges of the EN/SET pin and decodes them into 16 different states. The 16 current level settings available are indicated in Table 1.

**Table 1: Current Level Setting**

Data	Output(mA/Ch)	Data	Output(mA/Ch)
1	23.0	9	5.8
2	19.6	10	4.8
3	16.1	11	4.1
4	13.8	12	3.5
5	11.8	13	2.8
6	9.9	14	2.1
7	8.1	15	1.4
8	6.9	16	0.7

The PCC wire serial interface has flexible timing. After data is submitted, EN/SET is held high to latch the data. Once EN/SET has been held in the logic high state for time  $T_{LAT}$ , the programmed current becomes active and the internal data register is reset to zero.

For subsequent current level programming, the number of rising edges corresponding to the desired code must be entered on the EN/SET pin.

### PCC WIRE SERIAL INTERFACE TIMING

When EN/SET is held low for an amount of time greater than  $T_{OFF}$ , the IS31BL3212 enters into shutdown mode and draws 1.0 $\mu$ A typically from  $V_{CC}$ . The internal data register is reset to zero during shutdown.

# IS31BL3212

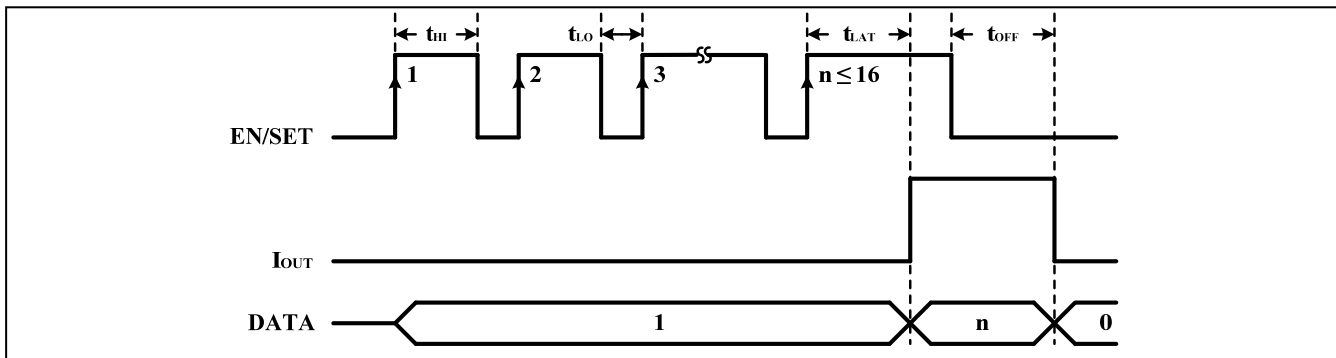

## LED SELECTION

The IS31BL3212 has low headroom voltage and it is designed to drive white-LEDs.

The drive current will automatically scale down to reduce the LED current consumption.

## INPUT CAPACITOR SELECTION

The IS31BL3212 is designed to run off of a fixed input voltage. Depending on the stability and condition of this voltage rail, it may be necessary to add a small input capacitor to help filter out any noise that may be present on the line. In the event that filtering is needed, ceramic composition capacitors are highly recommended over all other types of capacitors for use with the IS31BL3212. Ceramic capacitors offer many advantages over their tantalum and aluminum electrolytic counterparts. A ceramic capacitor typically has very low ESR, is lowest cost, has a smaller PCB footprint, and is non-polarized. Low ESR ceramic capacitors help to maximize charge pump transient response. Since ceramic capacitors are non-polarized, they are not prone to incorrect connection damage.

## THERMAL PROTECTION

The IS31BL3212 has a thermal protection circuit that will shut down the chip if the die temperature rises above the thermal limit.

Although the IS31BL3212 is designed for driving white LEDs, the device also can be used to drive most types of LEDs with forward voltage specifications ranging from 2.0V to 4.7V. LED applications may include main and sub-LCD display backlighting, camera photo-flash applications, color (RGB) LEDs, infrared (IR) diodes for remotes, and other loads benefiting from a controlled output current generated from a varying input voltage. Since the D1 to D4 output current sources are matched with negligible voltage dependence, the LED brightness will be matched regardless of the specific LED forward voltage ( $V_F$ ) levels. In some instances (e.g., in high luminous output applications such as photo flash), it may be necessary to drive high- $V_F$  type LEDs. The low dropout current sources in the IS31BL3212 make it capable of driving LEDs with forward voltages as high as 4.7V at full current from an input supply of 2.7V to 5.0V. Outputs can be paralleled to drive high-current LEDs without complication.

# IS31BL3212

## CLASSIFICATION REFLOW PROFILES

Profile Feature	Pb-Free Assembly
<b>Preheat &amp; Soak</b> Temperature min (T <sub>smin</sub> ) Temperature max (T <sub>smax</sub> ) Time (T <sub>smin</sub> to T <sub>smax</sub> ) (t <sub>s</sub> )	150°C 200°C 60-120 seconds
Average ramp-up rate (T <sub>smax</sub> to T <sub>p</sub> )	3°C/second max.
Liquidous temperature (T <sub>L</sub> ) Time at liquidous (t <sub>L</sub> )	217°C 60-150 seconds
Peak package body temperature (T <sub>p</sub> )*	Max 260°C
Time (t <sub>p</sub> )** within 5°C of the specified classification temperature (T <sub>c</sub> )	Max 30 seconds
Average ramp-down rate (T <sub>p</sub> to T <sub>smax</sub> )	6°C/second max.
Time 25°C to peak temperature	8 minutes max.

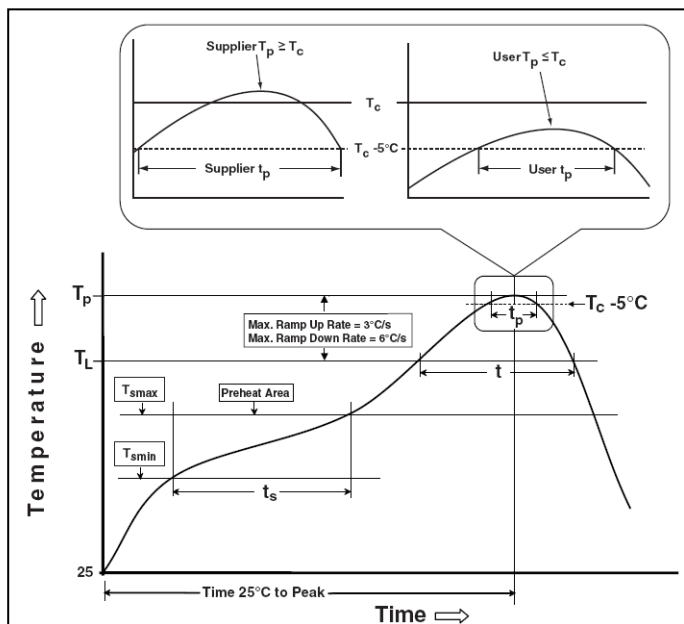

Figure 3 Classification Profile



# IS31BL3212

## PACKAGE INFORMATION

### DFN-8

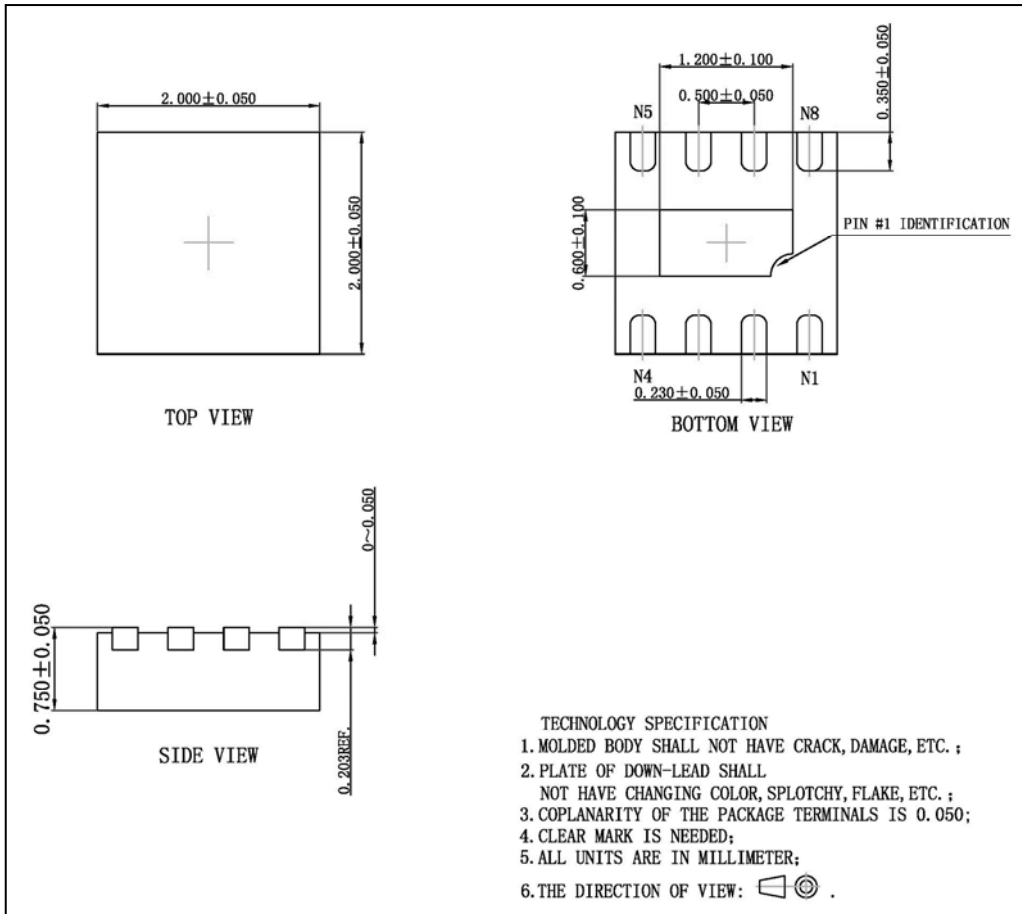

# IS31BL3212

## SOT23-6

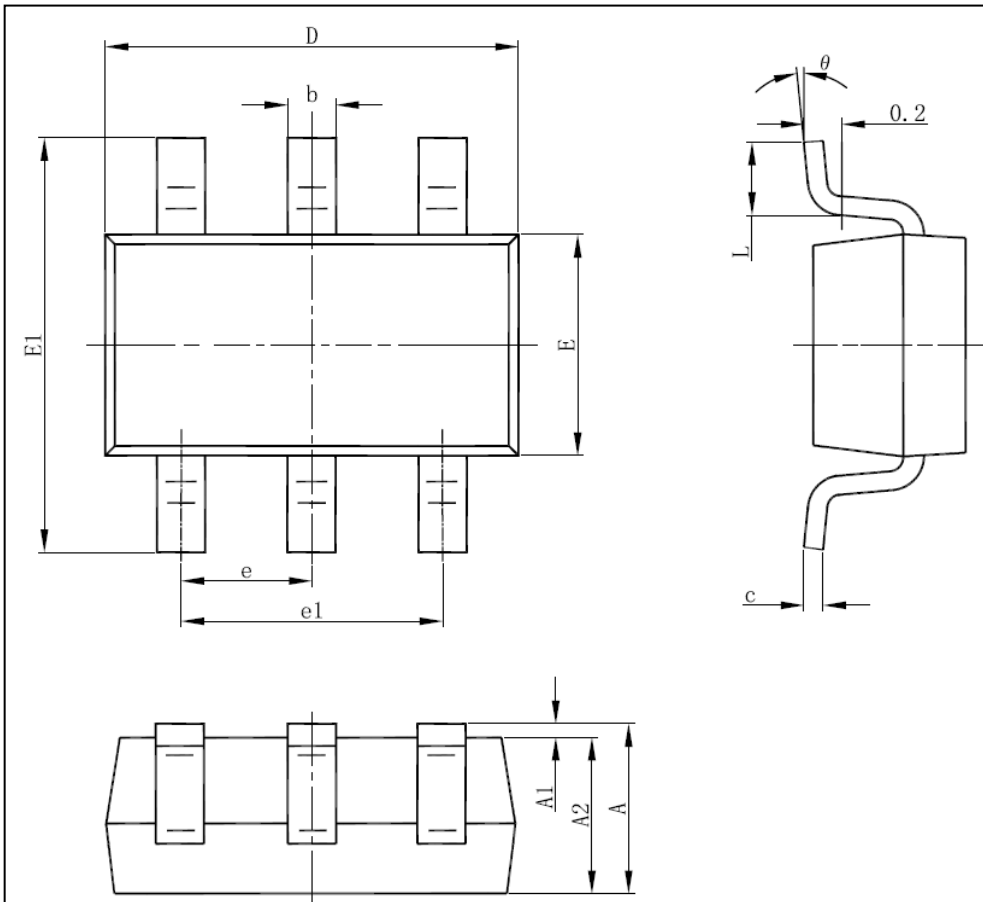

Symbol	Dimensions In Millimeters		Dimensions In Inches	
	Min	Max	Min	Max
A	1.050	1.250	0.041	0.049
A1	0.000	0.100	0.000	0.004
A2	1.050	1.150	0.041	0.045
b	0.300	0.500	0.012	0.020
c	0.100	0.200	0.004	0.008
D	2.820	3.020	0.111	0.119
E	1.500	1.700	0.059	0.067
E1	2.650	2.950	0.104	0.116
e	0.950(BSC)		0.037(BSC)	
e1	1.800	2.000	0.071	0.079
L	0.300	0.600	0.012	0.024
θ	0°	8°	0°	8°

**Note:** All dimensions in millimeters unless otherwise stated.

## X-ON Electronics

Largest Supplier of Electrical and Electronic Components

*Click to view similar products for [LED Lighting Drivers](#) category:*

*Click to view products by [ISSI](#) manufacturer:*

Other Similar products are found below :

[LV5235V-MPB-H](#) [MB39C602PNF-G-JNEFE1](#) [MIC2871YMK-T5](#) [AL1676-10BS7-13](#) [AL1676-20AS7-13](#) [AP5726WUG-7](#) [ICL8201](#)  
[IS31BL3228B-UTLS2-TR](#) [IS31BL3506B-TTLS2-TR](#) [AL3157F-7](#) [AP5725FDCG-7](#) [AP5726FDCG-7](#) [LV52204MTTBG](#) [AP5725WUG-7](#)  
[STP4CMPQTR](#) [NCL30086BDR2G](#) [CAT4004BHU2-GT3](#) [LV52207AXA-VH](#) [AP1694AS-13](#) [TLE4242EJ](#) [AS3688](#) [IS31LT3172-GRLS4-TR](#)  
[TLD2311EL](#) [KTD2694EDQ-TR](#) [KTZ8864EJAA-TR](#) [IS32LT3174-GRLA3-TR](#) [ZXLD1374QESTTC](#) [MP2488DN-LF-Z](#) [NLM0010XTSA1](#)  
[AL1676-20BS7-13](#) [ZXLD1370QESTTC](#) [MPQ7220GF-AEC1-P](#) [MPQ7220GR-AEC1-P](#) [MPQ4425BGJ-AEC1-P](#) [MPQ7220GF-AEC1-Z](#)  
[MPQ7220GR-AEC1-Z](#) [MPQ4425BGJ-AEC1-Z](#) [NCL30486A2DR2G](#) [IS31FL3737B-QFLS4-TR](#) [IS31FL3239-QFLS4-TR](#) [KTD2058EUAC-](#)  
[TR](#) [KTD2037EWE-TR](#) [DIO5662ST6](#) [IS31BL3508A-TTLS2-TR](#) [MAX20052CATC/V+](#) [MAX25606AUP/V+](#) [BD6586MUV-E2](#)  
[BD9206EFV-E2](#) [BD9416FS-E2](#) [LYT4227E](#)