

IS31BL3228B WHITE LED DRIVER EVALUATION BOARD GUIDE

DESCRIPTION

The IS31BL3228B is a low noise, constant frequency charge pump DC/DC converter for white LED applications. The IS31BL3228B is capable of driving up to six channels of LEDs at preset 20mA per channel from a 2.8V to 5.5V input. The current sinks may be operated individually or in parallel for driving higher current LEDs.

The serial digital input is used to enable, disable, and set current for each LED with 14 settings down to 1.8mA.

FEATURES

- Supply voltage range from 2.8V to 5.5V
- Fully programmable current with single wire
- 14 current levels
- Drives up to six channels of LEDs
- No inductors, low noise operation
- Built-in thermal protection
- Automatic soft start
- Low shutdown current: $I_{SHDN} < 3\mu A$
- UTQFN-12 (2mm × 2mm) package

QUICK START



Figure 1: Photo of IS31BL3228B Evaluation Board

RECOMMENDED EQUIPMENT

- 5.0V, 2A power supply

ABSOLUTE MAXIMUM RATINGS

- $\leq 5.5V$ power supply

Caution: Do not exceed the conditions listed above; otherwise the board will be damaged.

PROCEDURE

The IS31BL3228B evaluation board is fully assembled and tested. Follow the steps listed below to verify board operation.

Caution: Do not turn on the power supply until all connections are completed.

- 1) Connect the ground terminal of the power supply to the GND and the positive terminal to the VCC. Or connect the DC power to the connector (DC IN).
- 2) Turn on the power supply and pay attention to the supply current. If the current exceeds 600mA, please check for circuit fault.
- 3) Press Level- or Level+ button to change current of LEDs. The intensity of LEDs will be in 1 level (highest) when power on.
- 4) The button (SD/EN) controls the IS31BL3228B shutdown or enable. When power on the IS31BL3228B is enabled and the LED (D21) is on.

ORDERING INFORMATION

Part No.	Temperature Range	Package
IS31BL3228B-UTLS2-EB	-40°C to +85°C (Industrial)	UTQFN-12, Lead-free

Table 1: Ordering Information

For pricing, delivery, and ordering information, please contact Lumissil's analog marketing team at analog@lumissil.com or (408) 969-6600.

IS31BL3228B WHITE LED DRIVER EVALUATION BOARD GUIDE

EVALUATION BOARD OPERATION

The IS31BL3228B evaluation board performs constant output current with Pulse Count Control (PCC wire) serial interface. The interface records rising edges of the EN/SET pin and decodes them into 14 different states.

The evaluation board uses a MCU generating Pulse signal at EN/SET pin adjusting the LEDs current. There are 14 blue LEDs (D7~D20) above the buttons showing the intensity level.

Note: IS31BL3228B solely controls the white LEDs function on the evaluation board.

SOFTWARE SUPPORT

Please refer to the integrated program.

Note: The jumper JP1 is closed (Default). If JP1 is open, the MCU in the board will stop working and EN/SET pin will be in high-impedance state. The EN/SET pin (TP3) can be connected to external MCU to control the IS31BL3228B.

Please refer to the datasheet to get more information about IS31BL3228B.

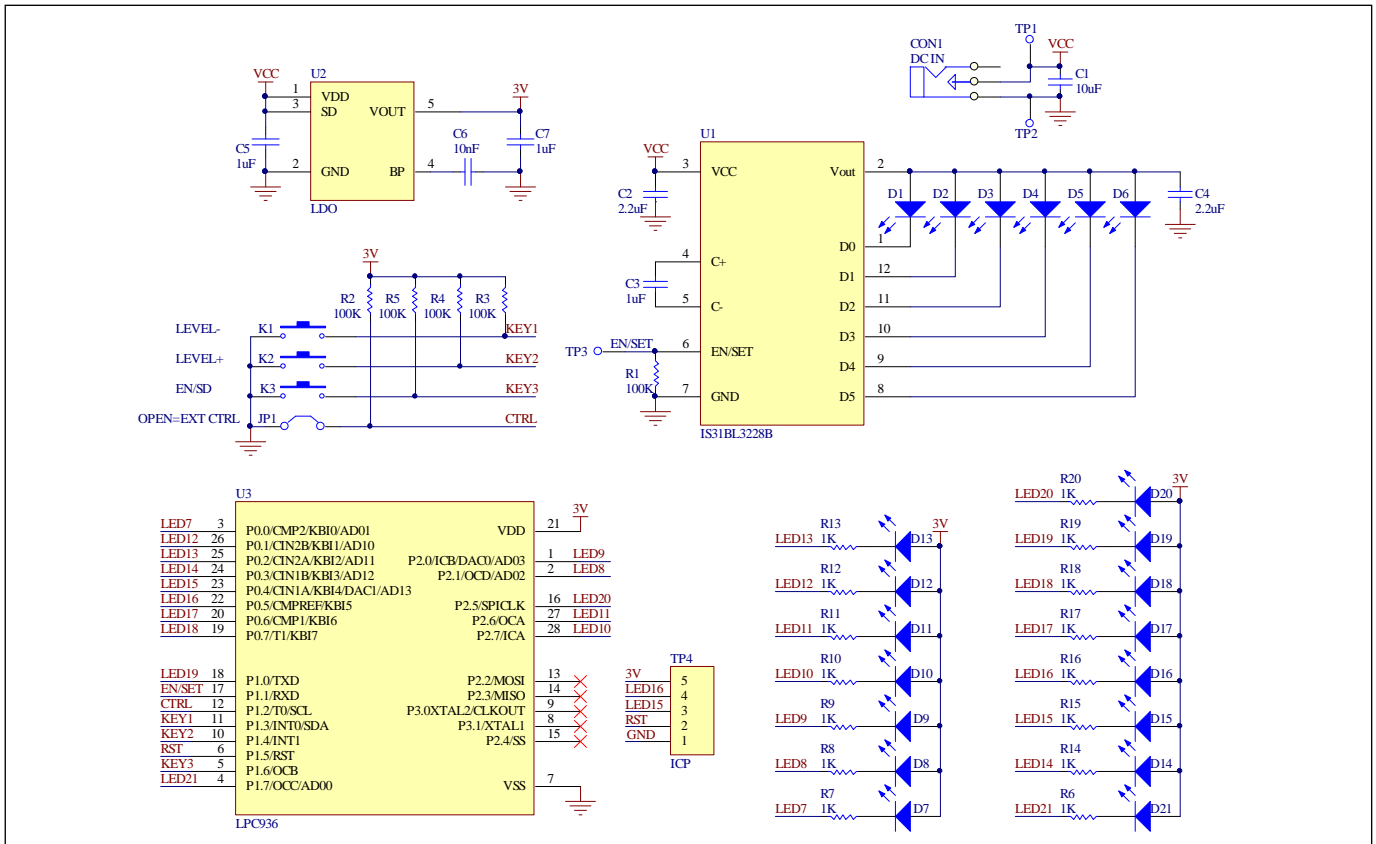

Figure 2: IS31BL3228B Application Schematic

IS31BL3228B WHITE LED DRIVER EVALUATION BOARD GUIDE

BILL OF MATERIALS

Name	Symbol	Description	Qty	Supplier	Part No.
LED Driver	U1	White LED driver	1	Lumissil	IS31BL3228B
LDO	U2	Low-dropout regulator	1	PAM	PAM3101
MCU	U3	Microcontroller	1	NXP	LPC936
LED	D7~D21	Diode, LED Blue, SMD	15	Everlight	19-217/BHC-ZL1M2RY/3T
LED	D1~D6	Diode, LED White, SMD	6	Everlight	EHP-C04/UT01-P01/TR
Resistor	R1~R5	RES,100k,1/16W,±5%,SMD	5	YAGEO	RC0603JR-07 100KL
Resistor	R6~R20	RES,1k,1/16W,±5%,SMD	15	YAGEO	RC0603JR-07 1KL
Capacitor	C1	CAP,10µF,16V,±10%,SMD	1	YAGEO	CC0805KRX7R7BB106
Capacitor	C2,C4	CAP, 2.2µF,16V,±10%,SMD	2	YAGEO	CC0603KRX7R7BB225
Capacitor	C3,C5,C7	CAP,1µF,16V,±10%,SMD	3	YAGEO	CC0603KRX7R7BB105
Capacitor	C6	CAP,10nF,16V,±10%,SMD	1	YAGEO	CC0603KRX7R7BB103
Button	K1~K3	Buttons SMD	3		

Bill of Materials, refer to Figure 2 above.

IS31BL3228B WHITE LED DRIVER EVALUATION BOARD GUIDE

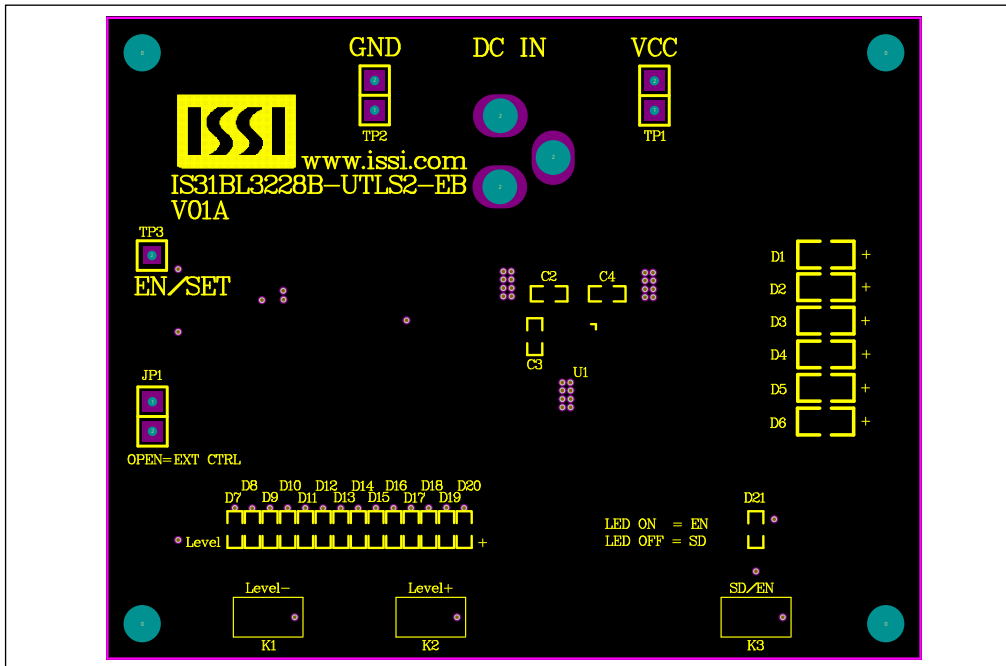

Figure 3: Board Component Placement Guide - Top Layer

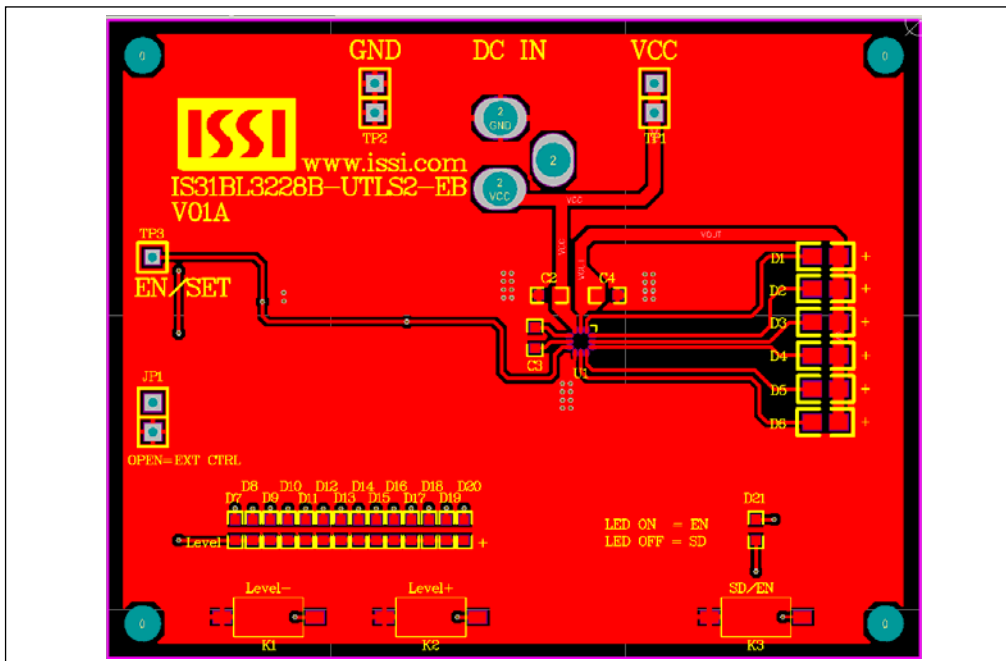

Figure 4: Board PCB Layout - Top Layer

IS31BL3228B WHITE LED DRIVER EVALUATION BOARD GUIDE

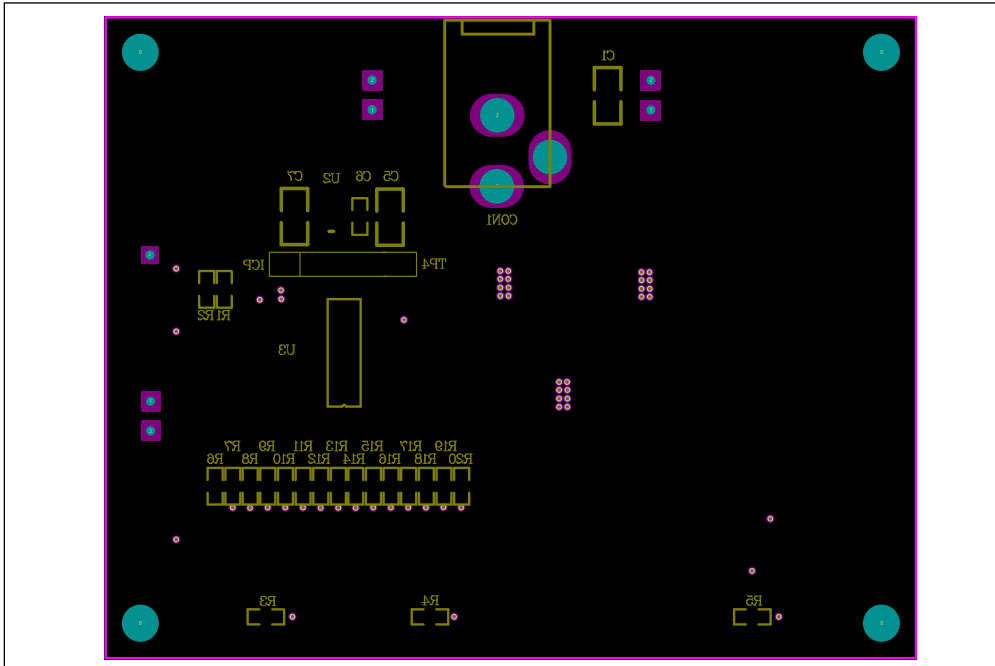

Figure 5: Board Component Placement Guide - Bottom Layer

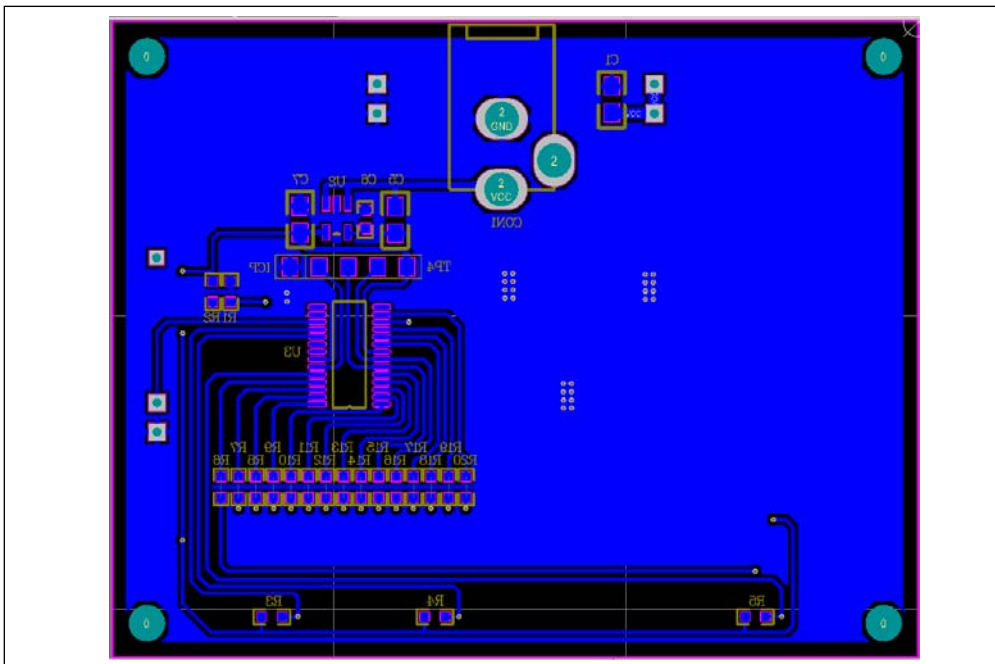

Figure 6: Board PCB Layout - Bottom Layer

Copyright © 2014 Lumissil Microsystems. All rights reserved. Lumissil Microsystems reserves the right to make changes to this specification and its products at any time without notice. Lumissil Microsystems assumes no liability arising out of the application or use of any information, products or services described herein. Customers are advised to obtain the latest version of this device specification before relying on any published information and before placing orders for products.

Lumissil Microsystems does not recommend the use of any of its products in life support applications where the failure or malfunction of the product can reasonably be expected to cause failure of the life support system or to significantly affect its safety or effectiveness. Products are not authorized for use in such applications unless Lumissil Microsystems receives written assurance to its satisfaction, that:

- the risk of injury or damage has been minimized;
- the user assume all such risks; and
- potential liability of Lumissil Microsystems is adequately protected under the circumstances

X-ON Electronics

Largest Supplier of Electrical and Electronic Components

Click to view similar products for [LED Lighting Development Tools](#) category:

Click to view products by [ISSI](#) manufacturer:

Other Similar products are found below :

[MIC2870YFT EV](#) [TDGL014](#) [ISL97682IRTZEVALZ](#) [EA6358NH](#) [TPS92315EVM-516](#) [STEVAL-LLL006V1](#) [IS31LT3948-GRLS4-EB](#)
[PIM526](#) [PIM527](#) [MAX6946EVKIT+](#) [MAX20070EVKIT#](#) [MAX20090BEVKIT#](#) [PIM498](#) [AP8800EV1](#) [ZXLD1370/1EV4](#) [1216.1013](#) [1270](#)
[1271.2004](#) [1272.1030](#) [1273.1010](#) [1278.1010](#) [1279.1002](#) [1279.1001](#) [1282.1000](#) [1293.1900](#) [1293.1800](#) [1293.1700](#) [1293.1500](#) [1293.1100](#)
[1282.1400](#) [1282.1100](#) [1293.1200](#) [1282.1200](#) [1293.1000](#) [1282.6000](#) [1296.2012](#) [MIKROE-2520](#) [1721](#) [1762](#) [PIR-GEVB](#) [TPS61161EVM-243](#)
[STEVAL-ILL056V1](#) [ADM00767](#) [STEVAL-ILL080V1](#) [DC1224A](#) [DC1160A](#) [DC1039A-A](#) [DC1816B](#) [DC1511A-A](#) [DC1274A](#)