

# IS31FL3191

## 1-CHANNEL FUN LED DRIVER

July 2021

### GENERAL DESCRIPTION

IS31FL3191 is a 1-channel fun LED driver which has One Shot Programming mode and PWM Control mode for LED lighting effects. The maximum output current can be adjusted in 5 levels (5mA~42mA).

In PWM Control mode, the PWM duty cycle of each output can be independently programmed and controlled in 256 steps to simplify color mixing. In One Shot Programming mode, the timing characteristics for output current - current rising, holding, falling and off time, can be adjusted individually.

IS31FL3191 is available in UTQFN-9 (1.5mm × 1.5mm). It operates from 2.7V to 5.5V over the temperature range of -40°C to +85°C.

### FEATURES

- Independently controlled automatic and semiautomatic breathing system-free pre-established pattern
- I2C interface, automatic address increment function
- Independently controlled output of 256 PWM steps
- 2.7V to 5.5V supply voltage
- 5 levels programmable output current
- Over-temperature protection
- Operating temperature  $T_A = -40^\circ\text{C} \sim +85^\circ\text{C}$
- UTQFN-9 (1.5mm × 1.5mm) package

### APPLICATIONS

- Mobile phones and other hand-held devices for LED display
- LED in home appliances

### TYPICAL APPLICATION CIRCUIT

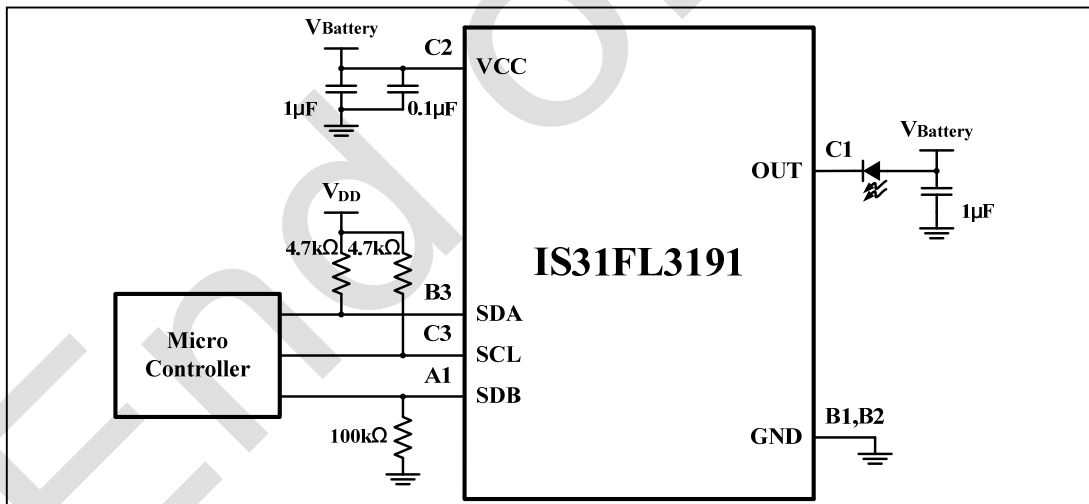
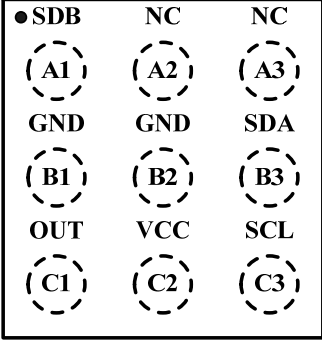

Figure 1 Typical Application Circuit

**Note:** The IC should be placed far away from the mobile antenna in order to prevent the EMI.

# IS31FL3191

## PIN CONFIGURATION

Package	Pin Configuration (Top View)
UTQFN-9	

## PIN DESCRIPTION

No.	Pin	Description
A1	SDB	Shutdown the chip when pulled to low.
A2, A3	NC	No connection.
B1, B2	GND	Ground.
B3	SDA	I2C serial data.
C1	OUT	Current source output.
C2	VCC	Power supply.
C3	SCL	I2C serial clock.

# IS31FL3191

## ORDERING INFORMATION

Industrial Range: -40°C to +85°C

Order Part No.	Package	QTY/Reel
IS31FL3191-UTLS2-TR	UTQFN-9, Lead-free	3000

End of Life

Copyright © 2021 Lumissil Microsystems. All rights reserved. Lumissil Microsystems reserves the right to make changes to this specification and its products at any time without notice. Lumissil Microsystems assumes no liability arising out of the application or use of any information, products or services described herein. Customers are advised to obtain the latest version of this device specification before relying on any published information and before placing orders for products.

Lumissil Microsystems does not recommend the use of any of its products in life support applications where the failure or malfunction of the product can reasonably be expected to cause failure of the life support system or to significantly affect its safety or effectiveness. Products are not authorized for use in such applications unless Lumissil Microsystems receives written assurance to its satisfaction, that:

- a.) the risk of injury or damage has been minimized;
- b.) the user assume all such risks; and
- c.) potential liability of Lumissil Microsystems is adequately protected under the circumstances

# IS31FL3191

## ABSOLUTE MAXIMUM RATINGS

Supply voltage, $V_{CC}$	-0.3V ~ +6.0V
Voltage at any input pin	-0.3V ~ $V_{CC}+0.3V$
Maximum junction temperature, $T_{JMAX}$	150°C
Operating temperature range, $T_A$	-40°C ~ +85°C
Storage temperature range, $T_{STG}$	-65°C ~ +150°C
ESD (HBM)	±8kV
ESD (CDM)	±1kV

**Note:** Stresses beyond those listed under "Absolute Maximum Ratings" may cause permanent damage to the device. These are stress ratings only and functional operation of the device at these or any other condition beyond those indicated in the operational sections of the specifications is not implied. Exposure to absolute maximum rating conditions for extended periods may affect device reliability.

## ELECTRICAL CHARACTERISTICS

$T_A = -40^\circ\text{C} \sim +85^\circ\text{C}$ ,  $V_{CC} = 5V$ , unless otherwise noted. Typical value are  $T_A = 25^\circ\text{C}$ .

Symbol	Parameter	Condition	Min.	Typ.	Max.	Unit
$V_{CC}$	Supply voltage		2.7		5.5	V
$I_{CC}$	Quiescent power supply current	$V_{SDB} = V_{CC}$		0.36		mA
$I_{SD}$	Shutdown current	$V_{SDB} = 0V$ or software shutdown			2.5	$\mu\text{A}$
$I_{OUT}$	Output current	PWM Control mode, $V_{DS} = 0.5V$ PWM Register(04h) = 0xFF Current Register(03h) = 0x00		42 (Note 1)		mA
$V_{HR}$	Current sink headroom voltage	$I_{OUT} = 42\text{mA}$		500		mV

### Logic Electrical Characteristics (SDA, SCL, SDB, AD)

$V_{IL}$	Logic "0" input voltage	$V_{CC} = 2.7V$			0.4	V
$V_{IH}$	Logic "1" input voltage	$V_{CC} = 5.5V$	1.4			V
$I_{IL}$	Logic "0" input current			5 (Note 2)		nA
$I_{IH}$	Logic "1" input current			5 (Note 2)		nA

# IS31FL3191

## DIGITAL INPUT SWITCHING CHARACTERISTICS (Note 3)

Symbol	Parameter	Condition	Min.	Typ.	Max.	Unit
$f_{SCL}$	Serial-Clock frequency				400	kHz
$t_{BUF}$	Bus free time between a STOP and a START condition		1.3			$\mu$ s
$t_{HD, STA}$	Hold time (repeated) START condition		0.6			$\mu$ s
$t_{SU, STA}$	Repeated START condition setup time		0.6			$\mu$ s
$t_{SU, STO}$	STOP condition setup time		0.6			$\mu$ s
$t_{HD, DAT}$	Data hold time				0.9	$\mu$ s
$t_{SU, DAT}$	Data setup time		100			ns
$t_{LOW}$	SCL clock low period		1.3			$\mu$ s
$t_{HIGH}$	SCL clock high period		0.7			$\mu$ s
$t_R$	Rise time of both SDA and SCL signals, receiving	(Note 4)		$20+0.1C_b$	300	ns
$t_F$	Fall time of both SDA and SCL signals, receiving	(Note 4)		$20+0.1C_b$	300	ns

**Note 1:**  $I_{OUT}$  represents the average output current. See PWM Register, Table 7.

**Note 2:** The LED is on.

**Note 3:** Guaranteed by design.

**Note 4:**  $C_b$  = total capacitance of one bus line in pF.  $I_{SINK} \leq 6mA$ .  $t_R$  and  $t_F$  measured between  $0.3 \times V_{CC}$  and  $0.7 \times V_{CC}$ .

# IS31FL3191

## DETAILED DESCRIPTION

### I2C INTERFACE

The IS31FL3191 uses a serial bus, which conforms to the I2C protocol, to control the chip's functions with two wires: SCL and SDA. The IS31FL3191 has a 7-bit slave address (A7:A1), followed by the R/W bit, A0. Since IS31FL3191 only supports write operations, A0 must always be "0".

The complete slave address is:

**Table 1 Slave Address (Write Only):**

Bit	A7:A1	A0
Value	1101 000	0

The SCL line is uni-directional. The SDA line is bi-directional (open-collector) with a pull-up resistor (typically 4.7kΩ). The maximum clock frequency specified by the I2C standard is 400kHz. In this discussion, the master is the microcontroller and the slave is the IS31FL3191.

The timing diagram for the I2C is shown in Figure 2. The SDA is latched in on the stable high level of the SCL. When there is no interface activity, the SDA line should be held high.

The "START" signal is generated by lowering the SDA signal while the SCL signal is high. The start signal will alert all devices attached to the I2C bus to check the incoming address against their own chip address.

The 8-bit chip address is sent next, most significant bit first. Each address bit must be stable while the SCL level is high.

After the last bit of the chip address is sent, the master checks for the IS31FL3191's acknowledge. The master releases the SDA line high (through a pull-up resistor). Then the master sends an SCL pulse. If the IS31FL3191 has received the address correctly, then it holds the SDA line low during the SCL pulse. If the SDA line is not low, then the master should send a "STOP" signal (discussed later) and abort the transfer.

Following acknowledge of IS31FL3191, the register address byte is sent, most significant bit first. IS31FL3191 must generate another acknowledge indicating that the register address has been received.

Then 8-bit of data byte are sent next, most significant bit first. Each data bit should be valid while the SCL level is stable high. After the data byte is sent, the IS31FL3191 must generate another acknowledge to indicate that the data was received.

The "STOP" signal ends the transfer. To signal "STOP", the SDA signal goes high while the SCL signal is high.

### ADDRESS AUTO INCREMENT

To write multiple bytes of data into IS31FL3191, load the address of the data register that the first data byte is intended for. During the IS31FL3191 acknowledge of receiving the data byte, the internal address pointer will increment by one. The next data byte sent to IS31FL3191 will be placed in the new address, and so on (Figure 5).

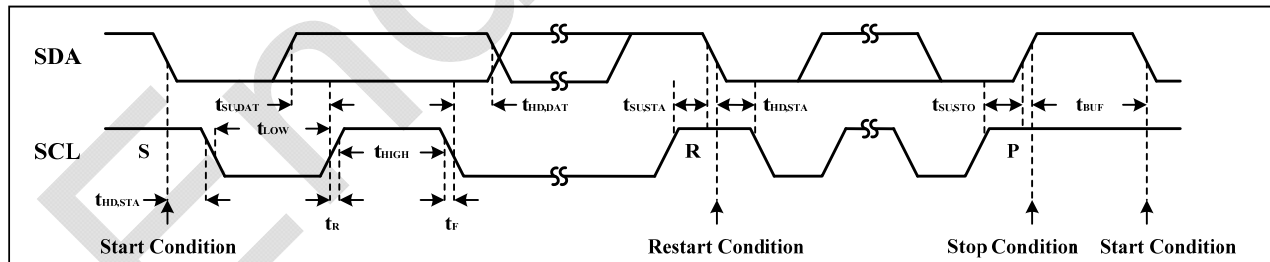

Figure 2 Interface Timing

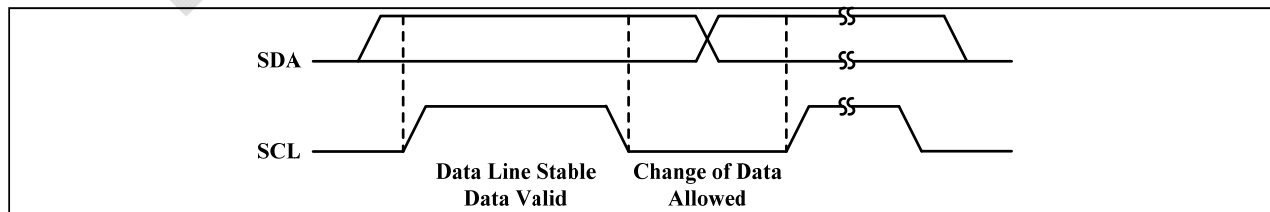
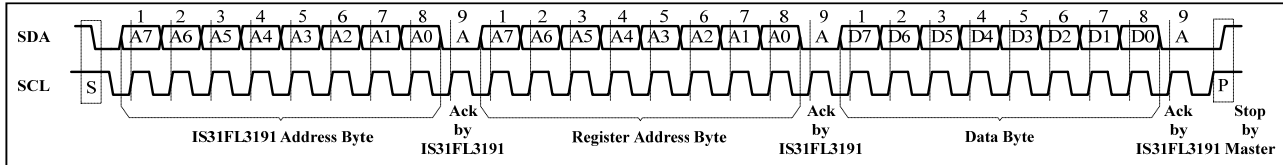
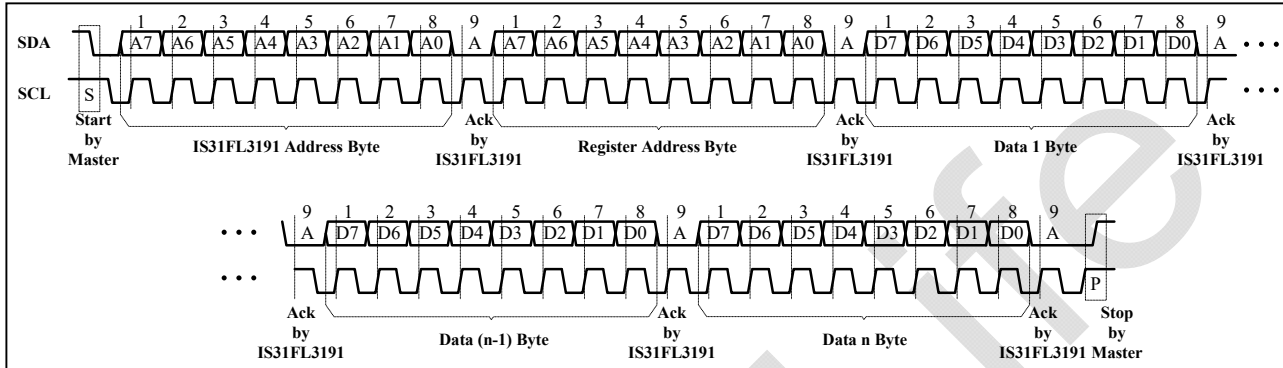

Figure 3 Bit Transfer



**Figure 4** Writing to IS31FL3191 (Typical)



**Figure 5** Writing to IS31FL3191 (Automatic Address Increment)

## REGISTERS DEFINITIONS

**Table 2** Register Function

Address	Name	Function	R/W	Table	Default
00h	Shutdown Register	Set software shutdown mode	W	3	0000 0001
01h	Breathing Control Register	Set the breathing function		4	0000 0000
02h	LED Mode Register	Set operation mode		5	
03h	Current Setting Register	Set output current		6	
04h	PWM Register	Channel PWM duty cycle data registers		7	
07h	PWM Update Register	Load PWM Registers data		-	xxxx xxxx
0Ah	T0 Register	Set the T0 time		8	0000 0000
10h	T1&T2 Register	Set the T1&T2 time		9	
16h	T3&T4 Register	Set the T3&T4 time		10	
1Ch	Time Update Register	Load time registers' data		-	xxxx xxxx
1Dh	LED Control Register	OUT enable bit		11	0000 0001
2Fh	Reset Register	Reset all registers to default value		-	xxxx xxxx

**Table 3** 00h Shutdown Register

Bit	D7:D6	D5	D4:D1	D0
Name	-	EN	-	SSD
Default	00	0	0000	1

The Shutdown Register sets software shutdown mode of IS31FL3191.

**EN** Channel Control  
 0 Channel disable  
 1 Channel enable

**SSD** Software Shutdown Enable  
 0 Normal operation  
 1 Software shutdown mode

# IS31FL3191

**Table 4 01h Breathing Control Register**

Bit	D7:D6	D5	D4	D3:D0
Name	-	RM	HT	-
Default	00	0	0	0000

The Breathing Control Register sets the breathing function.

**RM** Ramping Mode Enable  
 0 Disable  
 1 Enable

**HT** Hold Time Selection  
 0 Hold on T2  
 1 Hold on T4

**Table 5 02h LED Mode Register**

Bit	D7:D6	D5	D4:D0
Name	-	LED	-
Default	00	0	00000

The LED Mode Register sets operation mode of IS31FL3191.

**LED** LED Mode Selection  
 0 PWM Control Mode  
 1 One Shot Programming Mode

**Table 6 03h Current Setting Register**

Bit	D7:D5	D4:D2	D1:D0
Name	-	CS	-
Default	000	000	00

The Current Setting Register stores the maximum current setting,  $I_{MAX}$ , for all of the LED output channels.

**CS** Current Setting  
 000 42mA  
 001 10mA  
 010 5mA  
 011 30mA  
 1xx 17.5mA

**Table 7 04h PWM Register**

Bit	D7:D0
Name	PWM
Default	0000 0000

The value in the PWM Registers modulate the LEDs in 256 steps.

The value of the PWM Register decides the average output current. The average output current may be computed using the Formula (1):

$$I_{OUT} = \frac{I_{MAX}}{256} \cdot \sum_{n=0}^7 D[n] * 2^n \quad (1)$$

Where  $D[n]$  stands for the individual bit value, 1 or 0, in location  $n$ .

For example: if  $D7:D0 = 10110101$ ,

$$I_{OUT} = I_{MAX} (2^0 + 2^2 + 2^4 + 2^5 + 2^7) / 256$$

$I_{MAX}$  is set by Current Setting Register.

**07h PWM Update Register**

The data sent to the PWM Registers will be stored in temporary registers. A write operation of "0000 0000" value to the PWM Update Register is required to update the registers (04h).

**Table 8 0Ah T0 Register**

Bit	D7:D4	D3:D0
Name	T0	-
Default	0000	0000

The T0 Registers set the T0 time in One Shot Programming mode.

**T0** T0 Setting  
 0000 0s  
 0001 0.13s  
 0010 0.26s  
 0011 0.52s  
 0100 1.04s  
 0101 2.08s  
 0110 4.16s  
 0111 8.32s  
 1000 16.64s  
 1001 33.28s  
 1010 66.56s  
 Others Unavailable



# IS31FL3191

**Table 9 10h T1&T2 Register**

Bit	D7:D5	D4:D1	D0
Name	T1	T2	-
Default	000	0000	0

The T1&T2 Registers set the T1&T2 time in One Shot Programming mode.

**T1 T1 Setting**

000	0.13s
001	0.26s
010	0.52s
011	1.04s
100	2.08s
101	4.16s
110	8.32s
111	16.64s

**T2 T2 Setting**

0000	0s
0001	0.13s
0010	0.26s
0011	0.52s
0100	1.04s
0101	2.08s
0110	4.16s
0111	8.32s
1000	16.64s
Others	Unavailable

**Table 10 16h T3&T4 Register**

Bit	D7:D5	D4:D1	D0
Name	T3	T4	-
Default	000	0000	0

The T3&T4 Registers set the T3&T4 time in One Shot Programming mode.

**T3 T3 Setting**

000	0.13s
001	0.26s
010	0.52s
011	1.04s
100	2.08s
101	4.16s
110	8.32s
111	16.64s

**T4 T4 Setting**

0000	0s
0001	0.13s
0010	0.26s
0011	0.52s
0100	1.04s
0101	2.08s
0110	4.16s
0111	8.32s
1000	16.64s
1001	33.28s
1010	66.56s
Others	Unavailable

**1Ch Time Update Register**

The data sent to the time registers will be stored in temporary registers. A write operation of "0000 0000" value to the Time Update Register is required to update the registers (0Ah, 10h, 16h).

**Table 11 1Dh LED Control Register**

Bit	D7:D1	D0
Name	-	OUT
Default	0000 000	1

The LED Control Registers store the on or off state of each channel LED.

**OUT LED State**

0	LED off
1	LED on

**2Fh Reset Register**

Once user writes "0000 0000" to the Reset Register, IS31FL3191 will reset all registers to their default value. On initial power-up, the IS31FL3191 registers are reset to their default values for a blank display.

## FUNCTIONAL BLOCK DIAGRAM

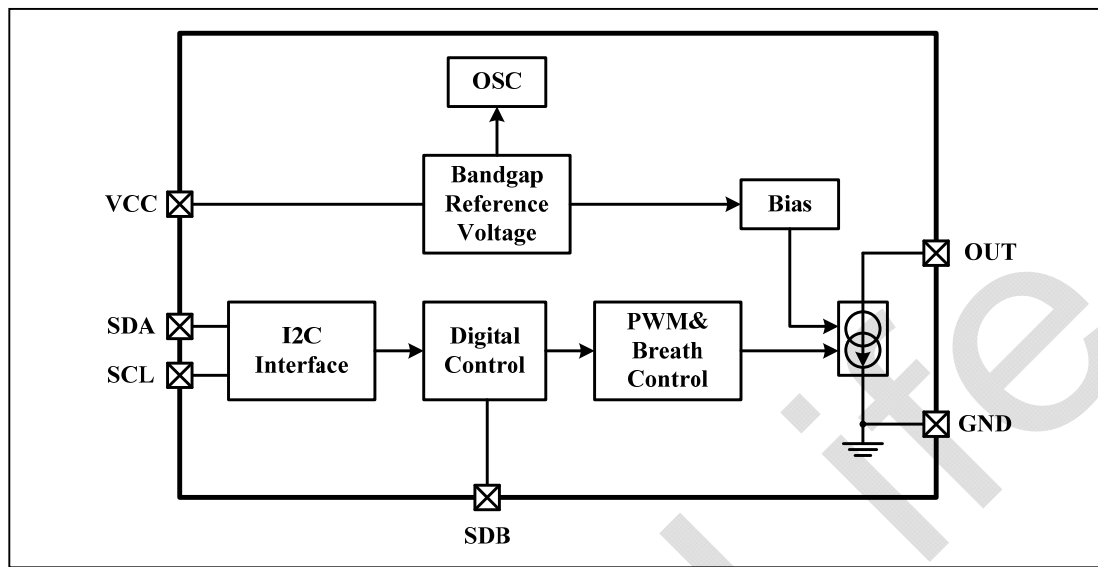

# IS31FL3191

## APPLICATION INFORMATION

### GENERAL DESCRIPTION

IS31FL3191 is a 1-channel LED driver with two-dimensional auto breathing and PWM Control mode. It can drive one individual LED.

### PWM CONTROL

By setting the LED bits of the LED Mode Register (03h) to "0", the IS31FL3191 will operate in PWM Control mode. The PWM Registers (04h) can modulate LED brightness of one channel with 256 steps. For example, if the data in PWM Register is "0000 0100", then the PWM is the fourth step, with a duty cycle of 4/256.

In PWM control mode, a new value must be written to the PWM registers to change the output PWM duty cycle. Writing new data continuously to the registers can modulate the brightness of the LEDs to achieve a breathing effect, blinking, or any other effects that the user defines.

### LED BREATHING CONTROL

By setting the LED bits of the LED Mode Register (03h) to "1", the IS31FL3191 will operate in One Shot Programming mode. In this mode, PWM Registers (04h) are unavailable and the LED intensity is automatically modulated in a breathing cycle, independently controlled by T0~T4. T0 is an offset time period which runs only once at the start of the cycle. The full cycle is T1 to T4 (Figure 6).

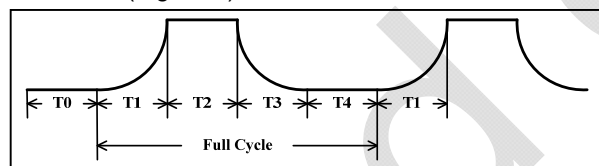

Figure 6 Breathing Timing

### SEMI-AUTOMATIC BREATHING

By setting the LED bits of the LED Mode Register (02h) to "1" and the RM bit of the Breathing Control Register (01h) to "1", the ramping function is enabled. HT is the time select bit. When HT bit is set to "0", T2 will be held forever, and the LED will remain at the programmed maximum intensity. When HT bit is set to "1", T3 will continue and T4 will be held, causing the LED to complete one breathing cycle and then remain off.

### SHUTDOWN MODE

Shutdown mode can either be used as a means of reducing power consumption or generating a flashing display (repeatedly entering and leaving shutdown mode). During shutdown mode all registers retain their data.

#### Software Shutdown

By setting SSD bit of the Shutdown Register (00h) to "1", the IS31FL3191 will operate in software shutdown mode, wherein they consume only 3.5µA (Typ.) current. When the IS31FL3191 is in software shutdown mode, all current sources are switched off.

#### Hardware Shutdown

The chip enters hardware shutdown mode when the SDB pin is pulled low, wherein they consume only 2.5µA (Typ.) current.

# IS31FL3191

## CLASSIFICATION REFLOW PROFILES

Profile Feature	Pb-Free Assembly
Preheat & Soak Temperature min (T <sub>smin</sub> ) Temperature max (T <sub>smax</sub> ) Time (T <sub>smin</sub> to T <sub>smax</sub> ) (t <sub>s</sub> )	150°C 200°C 60-120 seconds
Average ramp-up rate (T <sub>smax</sub> to T <sub>p</sub> )	3°C/second max.
Liquidous temperature (T <sub>L</sub> ) Time at liquidous (t <sub>L</sub> )	217°C 60-150 seconds
Peak package body temperature (T <sub>p</sub> )*	Max 260°C
Time (t <sub>p</sub> )** within 5°C of the specified classification temperature (T <sub>c</sub> )	Max 30 seconds
Average ramp-down rate (T <sub>p</sub> to T <sub>smax</sub> )	6°C/second max.
Time 25°C to peak temperature	8 minutes max.

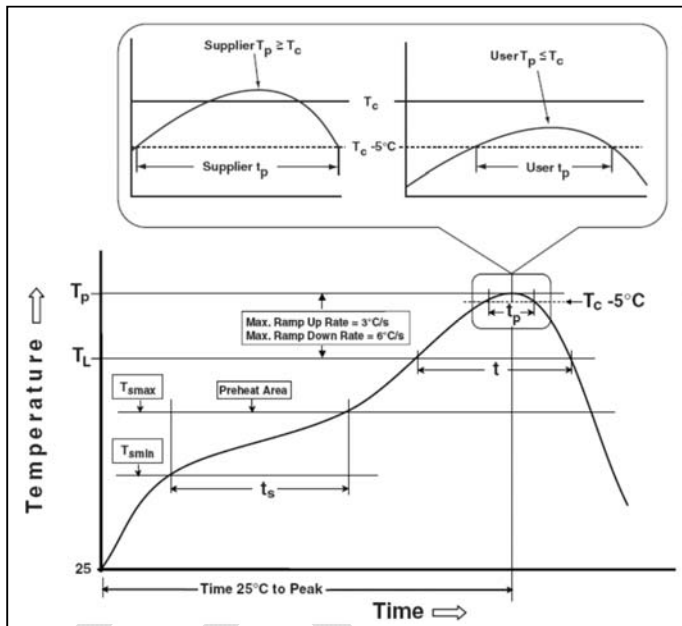
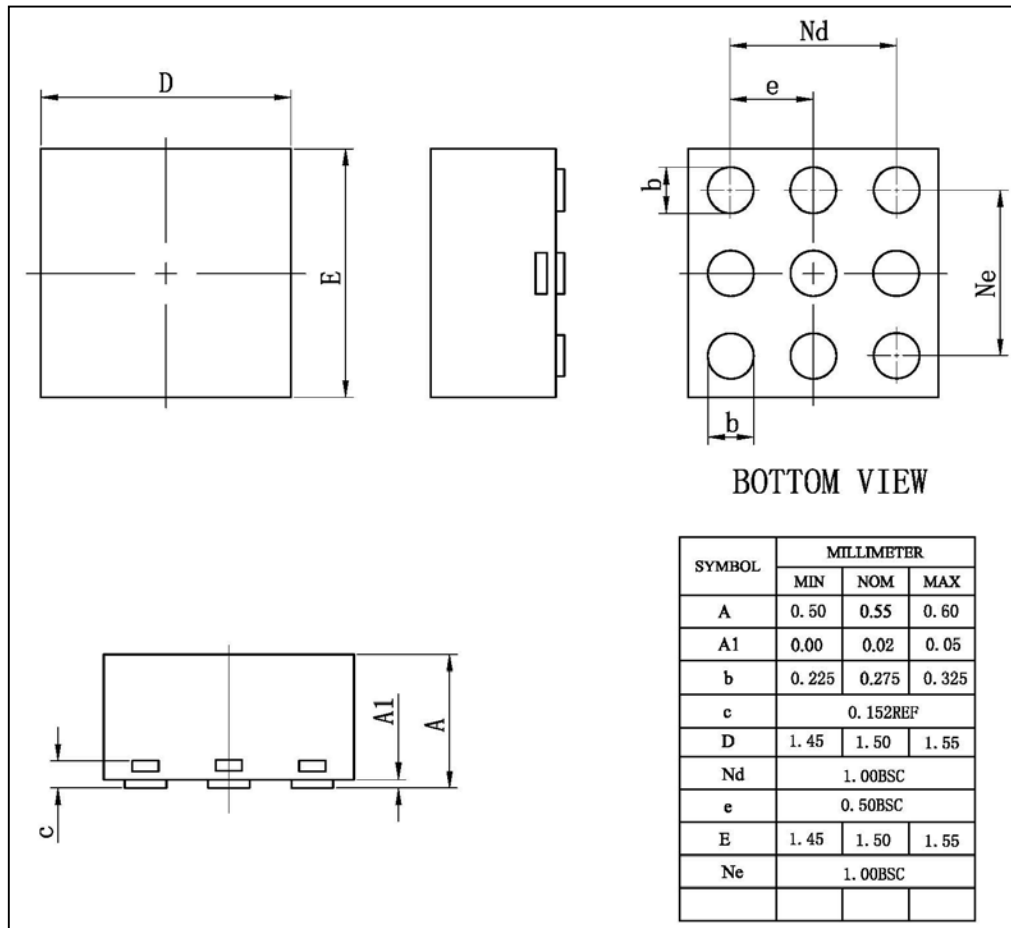

Figure 7 Classification Profile

# IS31FL3191

## PACKAGE INFORMATION

### UTQFN-9



# IS31FL3191

## RECOMMENDED LAND PATTERN

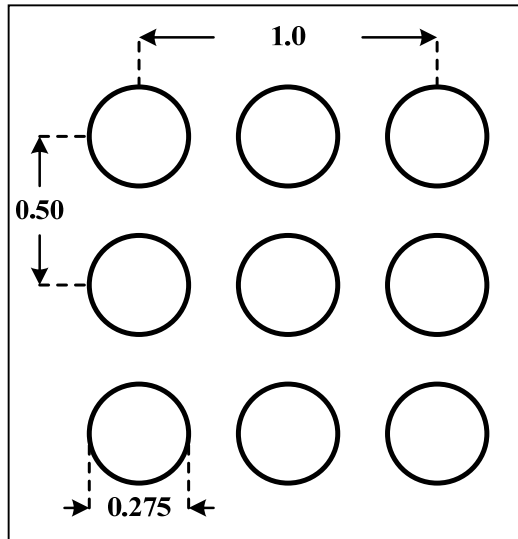

**Note:**

1. Land pattern complies to IPC-7351.
2. All dimensions in MM.
3. This document (including dimensions, notes & specs) is a recommendation based on typical circuit board manufacturing parameters. Since land pattern design depends on many factors unknown (eg. user's board manufacturing specs), user must determine suitability for use.

## REVISION HISTORY

Revision	Detail Information	Date
A	Initial release	2012.07.05
B	1. Update I2C writing figure 2. Add land pattern 3. Add ESD value 4. Add functional block	2015.07.10
C	Add EOL watermark	2021.07.05

End of Life

## X-ON Electronics

Largest Supplier of Electrical and Electronic Components

*Click to view similar products for [LED Lighting Drivers](#) category:*

*Click to view products by [ISSI](#) manufacturer:*

Other Similar products are found below :

[LV5235V-MPB-H](#) [MB39C602PNF-G-JNEFE1](#) [MIC2871YMK-T5](#) [AL1676-10BS7-13](#) [AL1676-20AS7-13](#) [AP5726WUG-7](#) [MX877RTR](#)  
[ICL8201](#) [IS31BL3228B-UTLS2-TR](#) [IS31BL3506B-TTLS2-TR](#) [AL3157F-7](#) [AP5725FDCG-7](#) [AP5726FDCG-7](#) [LV52204MTTBG](#)  
[AP5725WUG-7](#) [STP4CMPQTR](#) [NCL30086BDR2G](#) [CAT4004BHU2-GT3](#) [LV52207AXA-VH](#) [AP1694AS-13](#) [TLE4242EJ](#) [AS3688](#)  
[IS31LT3172-GRLS4-TR](#) [TLD2311EL](#) [KTD2694EDQ-TR](#) [KTZ8864EJAA-TR](#) [IS32LT3174-GRLA3-TR](#) [ZXLD1374QESTTC](#) [MP2488DN-](#)  
[LF-Z](#) [NLM0010XTSA1](#) [AL1676-20BS7-13](#) [MPQ7220GF-AEC1-P](#) [MPQ7220GF-AEC1-Z](#) [MPQ4425BGJ-AEC1-Z](#) [IS31FL3737B-QFLS4-](#)  
[TR](#) [IS31FL3239-QFLS4-TR](#) [KTD2058EUAC-TR](#) [KTD2037EWE-TR](#) [DIO5662ST6](#) [IS31BL3508A-TTLS2-TR](#) [MAX20052CATC/V+](#)  
[MAX25606AUP/V+](#) [BD6586MUV-E2](#) [BD9206EFV-E2](#) [BD9416FS-E2](#) [LYT4227E](#) [LYT6079C-TL](#) [MP3394SGF-P](#) [MP4689AGN-P](#)  
[MPQ4425AGQB-AEC1-Z](#)