

IS31FL3728

AUDIO MODULATED MATRIX LED DRIVER

June 2017

GENERAL DESCRIPTION

IS31FL3728 is a general purpose 8×8 LED matrix driver which features an audio frequency equalizer (EQ) mode or a general LED dot matrix display mode. The general LED matrix display defaults to an 8×8 configuration, however, it can be configured for a 5×11, 6×10, 7×9 dot matrix display. The matrix picture brightness can be modulated by audio. In either the audio EQ mode or matrix display mode, the array is internally scanned, and requires only one-time programming, thus eliminating the need for real time system resource utilization.

It programs the LED array through I2C interface. In the general purpose display mode, each dot of the LED array is independently programmed on or off over time. In the audio EQ mode, the X axis (column) represents the frequency bands while the Y axis (row) represents the strength of the input audio signal in each band. The number of LEDs lit in a column is proportional to the strength of the audio signal in the corresponding band in a thermometer-coded manner.

IS31FL3728 is available in 24-pin QFN (4mm × 4mm). It operates from 2.7V to 5.5V over the temperature range of -40°C to +85°C (IS31FL3728-QFLS2-TR), -40°C to +105°C (IS31FL3728-QFLS3-TR).

FEATURES

- 5~8 current source outputs for row control
- 8~11 outputs for column scan control
- Programmable 8×8, 7×9, 6×10, 5×11 matrix
- One-time programming, internal scan
- Full scale LED current controlled by internal register setting or audio signal
- Audio frequency EQ display with programmable input gain
- LED matrix brightness can be modulated with audio Signal
- One address pin with 4 logic levels to allow four I2C slave addresses
- I2C interface
- 2.7V to 5.5V supply
- Over-temperature protection
- QFN-24 (4mm × 4mm) package

APPLICATIONS

- Mobile phones and other hand-held devices for LED displays.
- Audio frequency equalizer display

TYPICAL APPLICATION CIRCUIT

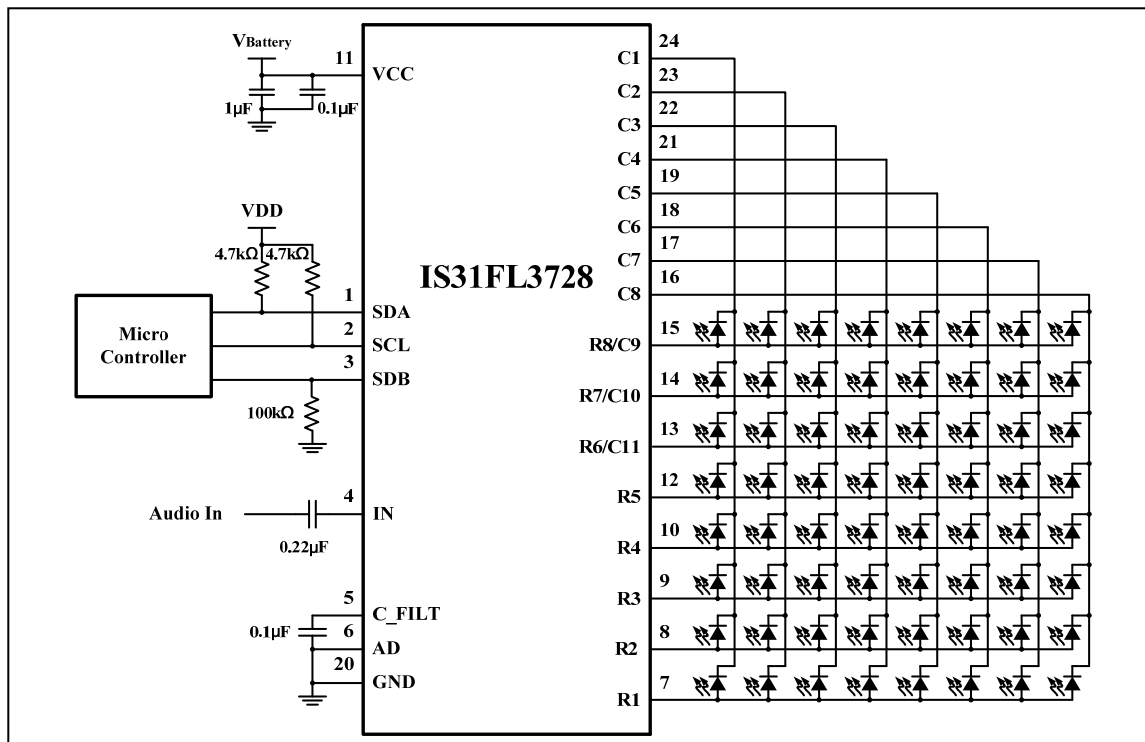
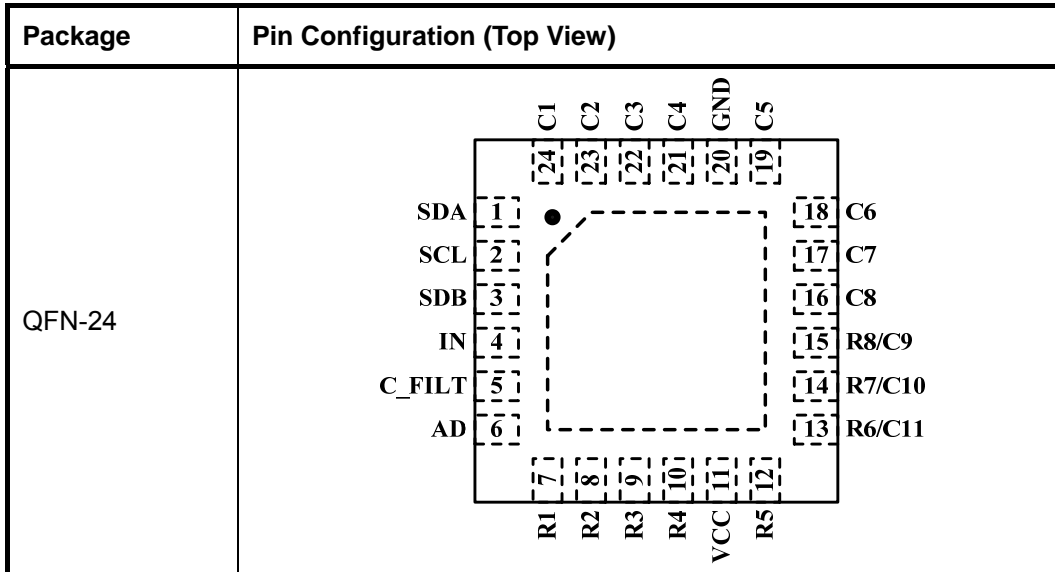

Figure 1 Typical Application Circuit

IS31FL3728

PIN CONFIGURATION



PIN DESCRIPTION

No.	Pin	Description
1	SDA	Serial data.
2	SCL	Serial clock.
3	SDB	Shutdown the chip when pull to low.
4	IN	Audio input.
5	C_FILT	Low pass filter cap for audio control.
6	AD	I2C Address setting.
7~10, 12	R1~R5	Current source outputs.
11	VCC	Power supply.
13~15	R6/C11, R7/C10, R8/C9	CMOS outputs.
16~19, 21~24	C8~C1	Current sink outputs.
20	GND	Ground.
	Thermal Pad	Connect to GND.

IS31FL3728

ORDERING INFORMATION

Industrial Range: -40°C to +85°C

Order Part No.	Package	QTY/Reel
IS31FL3728-QFLS2-TR	QFN-24, Lead-free	2500

Industrial Range: -40°C to +105°C

Order Part No.	Package	QTY/Reel
IS31FL3728-QFLS3-TR	QFN-24, Lead-free	2500

Copyright © 2017 Lumissil Microsystems. All rights reserved. Lumissil Microsystems reserves the right to make changes to this specification and its products at any time without notice. Lumissil Microsystems assumes no liability arising out of the application or use of any information, products or services described herein. Customers are advised to obtain the latest version of this device specification before relying on any published information and before placing orders for products.

Lumissil Microsystems does not recommend the use of any of its products in life support applications where the failure or malfunction of the product can reasonably be expected to cause failure of the life support system or to significantly affect its safety or effectiveness. Products are not authorized for use in such applications unless Lumissil Microsystems receives written assurance to its satisfaction, that:

- a.) the risk of injury or damage has been minimized;
- b.) the user assume all such risks; and
- c.) potential liability of Lumissil Microsystems is adequately protected under the circumstances

IS31FL3728

ABSOLUTE MAXIMUM RATINGS

Supply voltage, V_{CC}	-0.3V ~ +6.0V
Voltage at any input pin	-0.3V ~ $V_{CC}+0.3V$
Maximum junction temperature, T_{JMAX}	150°C
Storage temperature range, T_{STG}	-65°C ~ +150°C
Operating temperature range, $T_A = T_J$	-40°C ~ +85°C, IS31FL3728-QFLS2-TR -40°C ~ +105°C, IS31FL3728-QFLS3-TR
Junction to ambient, θ_{JA}	32.9°C/W
ESD (HBM) for all pins except C5	±2kV
ESD (CDM)	±1kV

Note: Stresses beyond those listed under "Absolute Maximum Ratings" may cause permanent damage to the device. These are stress ratings only and functional operation of the device at these or any other condition beyond those indicated in the operational sections of the specifications is not implied. Exposure to absolute maximum rating conditions for extended periods may affect device reliability.

ELECTRICAL CHARACTERISTICS

The following specifications apply for $V_{CC} = 5V$, $T_A = 25^\circ C$, unless otherwise noted.

Symbol	Parameter	Condition	Min.	Typ.	Max.	Unit
V_{CC}	Supply voltage		2.7		5.5	V
I_{CC}	Quiescent power supply current	$V_{IN} = 0V$, register CD1:CD11 = 0 dot matrix display mode without audio modulation		4.1	5.0	mA
I_{SD}	Shutdown current	$V_{SDB} = 0V$		1.7	5.0	μA
		$V_{SDB} = 5V$ Software Shutdown		1.7	5.0	μA
I_{OUT}	Output current of R1~R8	Dot matrix display mode without audio modulation		42.8 (Note 1)		mA
		Dot matrix display mode with audio modulation $V_{IN} = 1.5V_{p-p}$, 1kHz square wave, audio gain = 0dB		42.3 (Note 1)		mA
V_{HR}	Current sink (I_{SINK} , C1:C8) headroom voltage and current source (I_{OUT} , R1:R8) headroom voltage	$I_{SINK} = 320mA$ (Note 2)		300		mV
		$I_{OUT} = 40mA$		200		

Logic Electrical Characteristics

$V_{IN(0)}$	Logic "0" input voltage	$V_{CC} = 2.7V$			0.4	V
$V_{IN(1)}$	Logic "1" input voltage	$V_{CC} = 5.5V$	1.4			V
$I_{IN(0)}$	Logic "0" input current	$V_{IN} = 0V$ (Note 3)		5		nA
$I_{IN(1)}$	Logic "1" input current	$V_{IN} = V_{CC}$ (Note 3)		5		nA

IS31FL3728

DIGITAL INPUT SWITCHING CHARACTERISTICS (Note 3)

Symbol	Parameter	Condition	Min.	Typ.	Max.	Unit
f_{SCL}	Serial-clock frequency				400	kHz
t_{BUF}	Bus free time between a STOP and a START condition		1.3			μ s
$t_{HD, STA}$	Hold time (repeated) START condition		0.6			μ s
$t_{SU, STA}$	Repeated START condition setup time		0.6			μ s
$t_{SU, STO}$	STOP condition setup time		0.6			μ s
$t_{HD, DAT}$	Data hold time				0.9	μ s
$t_{SU, DAT}$	Data setup time		100			ns
t_{LOW}	SCL clock low period		1.3			μ s
t_{HIGH}	SCL clock high period		0.7			μ s
t_R	Rise time of both SDA and SCL signals, receiving	(Note 4)		$20 + 0.1C_b$	300	ns
t_F	Fall time of both SDA and SCL signals, receiving	(Note 4)		$20 + 0.1C_b$	300	ns

Note 1: Current of Single LED in Rx(x=1~8) is $I_{OUT}/8$.

Note 2: All Row Drivers are ON.

Note 3: Guaranteed by design.

Note 4: C_b = total capacitance of one bus line in pF. $I_{SINK} \leq 6mA$. t_R and t_F measured between $0.3 \times V_{CC}$ and $0.7 \times V_{CC}$.

IS31FL3728

REGISTERS DEFINITION

00h Configuration Register

Bit	D7	D6:D3	D2	D1:D0
Name	SSD	-	Audio_EN	ADM
Default	0	0000	0	00

The Configuration Register sets operation mode of IS31FL3728.

SSD Software Shutdown Enable
 0 Normal operation
 1 Software shutdown mode

Audio_EN Audio Input Enable
 0 Matrix intensity is controlled by the current setting in the Lighting Effect Register (0Dh)
 1 Enable audio signal to modulate the intensity of the matrix in dot matrix display mode

ADM Array Mode Selection
 00 8×8 dot matrix display mode
 01 7×9 dot matrix display mode
 10 6×10 dot matrix display mode
 11 5×11 dot matrix display mode

01h~0Bh Column Data Register (C1~C11)

Bit	D7:D0
Name	R8:R1
Default	0000 0000

The column data registers store the on or off state of each LED in the array.

Rx LED State
 0 LED off
 1 LED on

The data in the column data registers is valid only when the chip is configured in general purpose dot matrix display mode. 11 registers are assigned to CD1~CD11 columns respectively; the LED at a particular (row, column) location will be turned on when the respective data is set to 1. When configured to other than 8×8 dot matrix display mode operation, only the required number of LSBs is used in each column register. For example, in 5×11 dot matrix display mode, only bits R5 through R1 are used, and bits R8 through R6 are ignored.

0C Update Column Register

The data sent to the column data registers will be stored in temporary registers. A write operation of "0000 0000" value to the Update Column Register is required to update the Column Data Registers (01h: 0Bh).

0Dh Lighting Effect Register

Bit	D7	D6:D4	D3:D0
Name	-	AGS	CS
Default	0	000	0000

The Lighting Effect Register stores the intensity control settings for all of the LEDs in the array

AGS Audio Input Gain Selection
 000 0dB
 001 +3dB
 010 +6dB
 011 +9dB
 100 +12dB
 101 +15dB
 110 +18dB
 111 -6dB

CS Full Current Setting For Each Row Output
 0000 40mA
 0001 45mA

 0111 75mA
 1000 5mA
 1001 10mA

 1110 35mA

0Fh Audio_EQ Register

Bit	D7	D6	D5:D0
Name	-	AE_EN	-
Default	0	0	000000

The Audio_EQ Register enables the audio frequency equalizer (audio EQ) mode

AE_EN Audio EQ Mode
 0 Disable
 1 Enable

IS31FL3728

APPLICATION INFORMATION

AUDIO FREQUENCY EQUALIZER (AUDIO EQ) MODE

The IS31FL3728 features audio frequency equalizer mode, or audio EQ mode.

The current of the matrix is adjusted by Lighting Effect Register as dot matrix display mode.

In the audio EQ mode, only 8 columns are valid and display the three bands of the audio signal. When the IS31FL3728 is configured as 7×9, 6×10 or 5×11, only columns C1 thru C8 will be used, and the remaining columns will always be off.

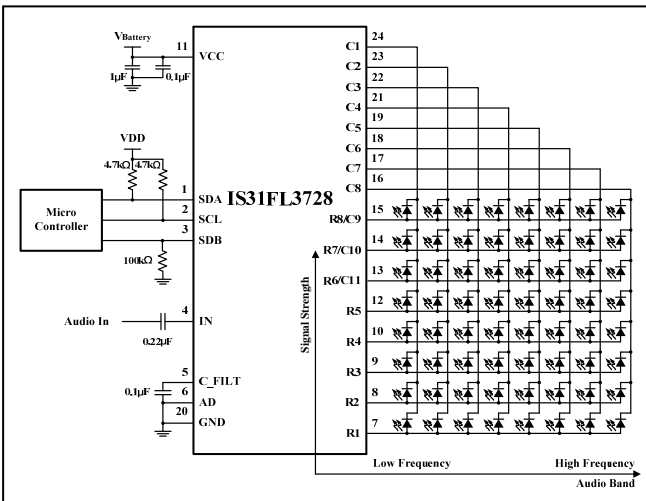

Figure 5 Audio EQ Mode

GENERAL PURPOSE DOT MATRIX DISPLAY MODE

The general purpose dot matrix display timing diagram is shown in Figure 6. The IS31FL3728 is configured as general purpose 8×8 dot matrix display mode at initial power up. Column controls C[8:1] scans the eight columns at a rate of 3.79KHz, or 264us per frame. Each column is effective for 32us. The non-overlap interval between adjacent columns is 1us.

The IS31FL3728 also can be configured as 7×9, 6×10 or 5×11 dot matrix display mode. The frame period is changed slightly depending on the number of columns required to scan by an additional time of 33us per column. For example, when in 7×9 dot matrix display mode, the column data registers' MSB will be invalid and column controls C[9:1] scans the nine columns 297us per frame.

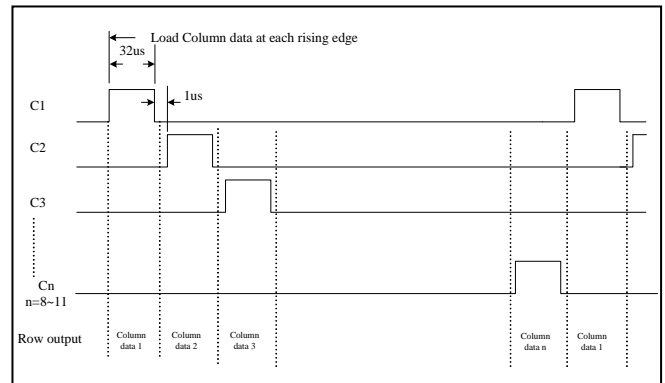

Figure 6 Dot Matrix Display Timing Diagram

8×8 DOT MATRIX DISPLAY MODE

The application example in Figure 1 shows the IS31FL3728 in the 8×8 LED dot matrix display mode.

The LED columns have common cathodes and are connected to the C1:C8 outputs. The rows are connected to the row drivers. Each of the 64 LEDs can be addressed separately. The columns are selected via the registers 01h~08h as described in the registers definition section.

5×11 DOT MATRIX DISPLAY MODE

By setting D1&D0 of the Configuration Register to 11, the IS31FL3728 will operate in the 5×11 LED dot matrix display mode.

The LED columns have common cathodes and are connected to the C1:C11 outputs. The rows are connected to the row drivers. Each of the 55 LEDs can be addressed separately. The three MSBs of each register, R8~R6, are ignored. The columns are selected via the registers as described in the registers definition section.

DOT MATRIX DISPLAY MODE WITH AUDIO MODULATION

When the IS31FL3728 operates in any of the Dot Matrix modes, if the bit Audio_EN in Configuration register is set to 1, the panel will get the effect of audio modulation

INITIAL POWER-UP

On initial power-up, the IS31FL3728 registers are reset to their default values for a blank display. At this time, all registers should be programmed for the desired operation.

IS31FL3728

SOFTWARE SHUTDOWN MODE

The IS31FL3728 devices feature a software shutdown mode, wherein they consume only 1.7 μ A (typ.) current. Shutdown mode is entered via a write to the Configuration Register. When the IS31FL3728 is in shutdown mode, all current sources and digital drivers are switched off, so that the array is blanked.

Shutdown mode can either be used as a means of reducing power consumption or generating a flashing display (repeatedly entering and leaving shutdown mode).

Note, during shutdown mode all registers retain their data.

IS31FL3728

CLASSIFICATION REFLOW PROFILES

Profile Feature	Pb-Free Assembly
Preheat & Soak Temperature min (T _{smin}) Temperature max (T _{smax}) Time (T _{smin} to T _{smax}) (t _s)	150°C 200°C 60-120 seconds
Average ramp-up rate (T _{smax} to T _p)	3°C/second max.
Liquidous temperature (T _L) Time at liquidous (t _L)	217°C 60-150 seconds
Peak package body temperature (T _p)*	Max 260°C
Time (t _p)** within 5°C of the specified classification temperature (T _c)	Max 30 seconds
Average ramp-down rate (T _p to T _{smax})	6°C/second max.
Time 25°C to peak temperature	8 minutes max.

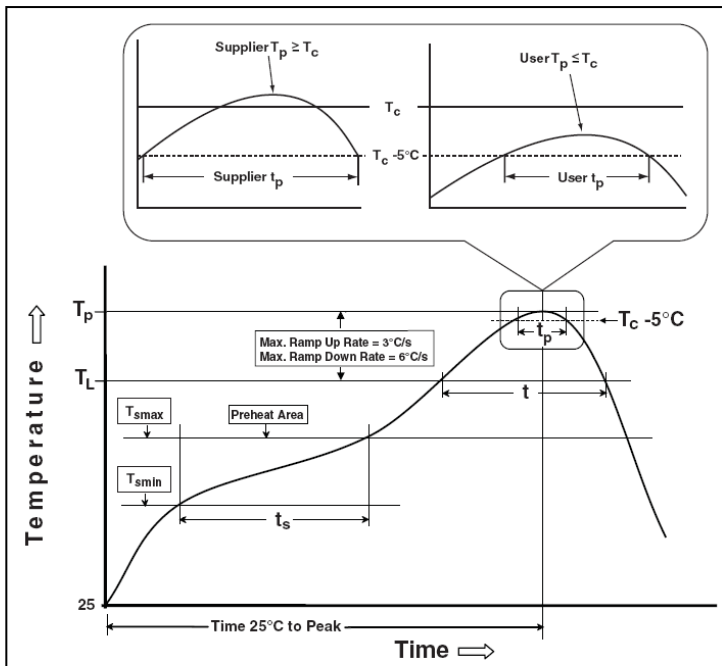
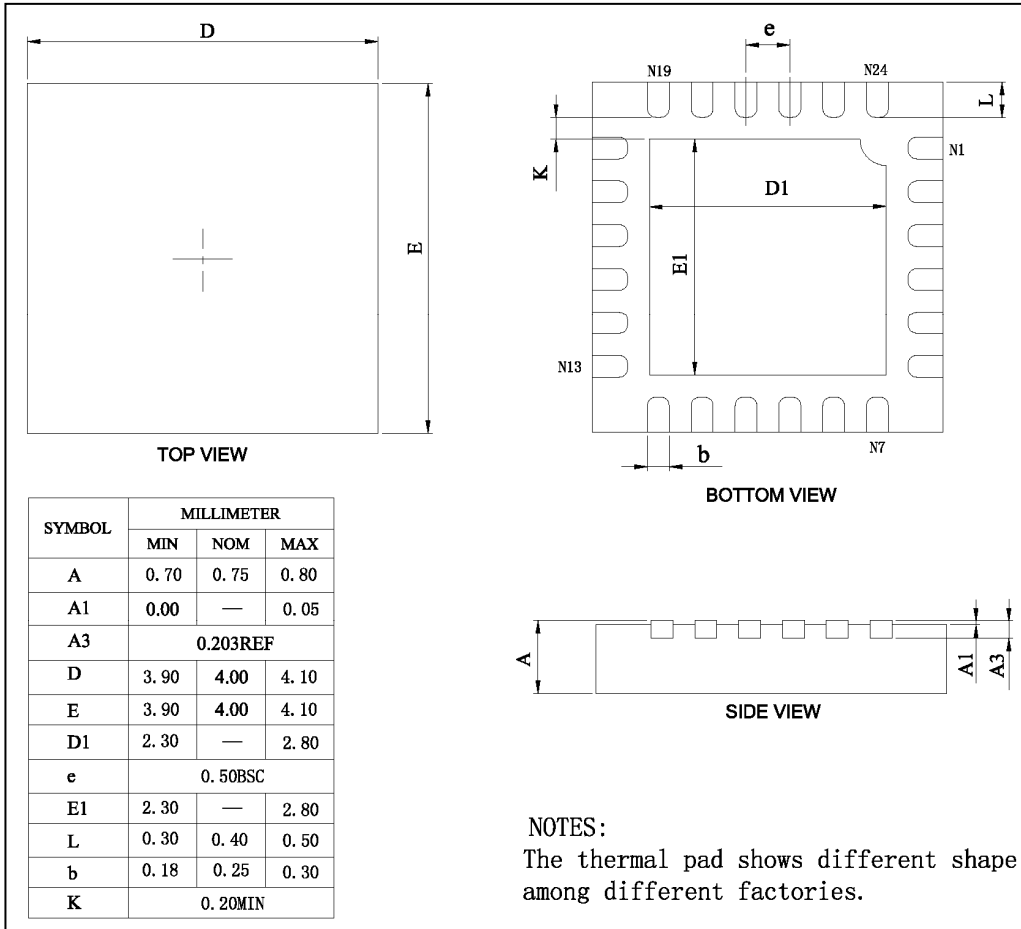

Figure 7 Classification Profile

IS31FL3728

PACKAGE INFORMATION

QFN-24



IS31FL3728

RECOMMENDED LAND PATTERN

QFN-24

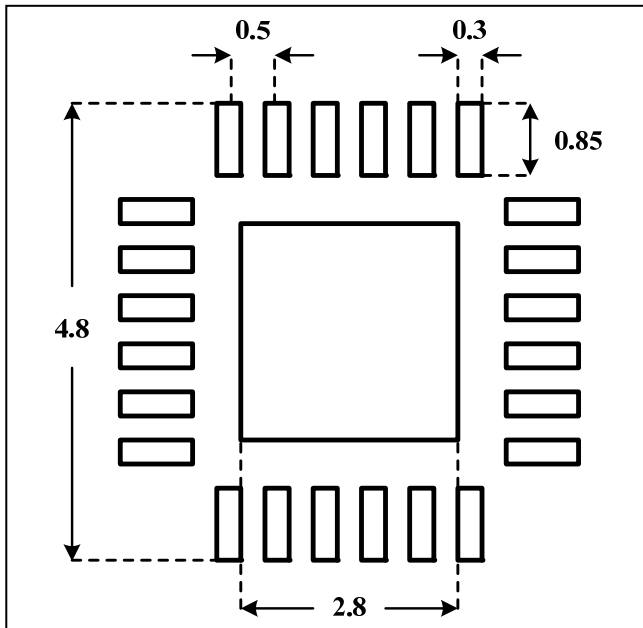

Note:

1. Land pattern complies to IPC-7351.
2. All dimensions in MM.
3. This document (including dimensions, notes & specs) is a recommendation based on typical circuit board manufacturing parameters. Since land pattern design depends on many factors unknown (eg. user's board manufacturing specs), user must determine suitability for use.

REVISION HISTORY

Revision	Detail Information	Date
A	Initial release	2011.12.19
B	<ol style="list-style-type: none">1. Add S3 temperature parameters.2. Add ESD (HBM/CDM) value and θ_{JA}.3. Update POD.4. Add Land pattern.5. Deleted tape and reel information.6. I_{OUT} test condition changes from $V_{IN} = 1.0V_{p-p}$ to $V_{IN} = 1.5V_{p-p}$.7. I_{SD} Typ. changes from 0.2 to 1.7.8. I_{SD} Max. changes from 1.0 to 5.0.	2016.11.15
C	<ol style="list-style-type: none">1. Update θ_{JA} to 32.9°C/W2. Update ESD (HBM) from 4kV to 2kV	2017.05.15

X-ON Electronics

Largest Supplier of Electrical and Electronic Components

Click to view similar products for [LED Lighting Drivers](#) category:

Click to view products by [ISSI](#) manufacturer:

Other Similar products are found below :

[LV5235V-MPB-H](#) [MB39C602PNF-G-JNEFE1](#) [MIC2871YMK-T5](#) [AL1676-10BS7-13](#) [AL1676-20AS7-13](#) [AP5726WUG-7](#) [MX877RTR](#)
[ICL8201](#) [IS31BL3228B-UTLS2-TR](#) [IS31BL3506B-TTLS2-TR](#) [AL3157F-7](#) [AP5725FDCG-7](#) [AP5726FDCG-7](#) [LV52204MTTBG](#)
[AP5725WUG-7](#) [STP4CMPQTR](#) [NCL30086BDR2G](#) [CAT4004BHU2-GT3](#) [LV52207AXA-VH](#) [AP1694AS-13](#) [TLE4242EJ](#) [AS3688](#)
[IS31LT3172-GRLS4-TR](#) [TLD2311EL](#) [KTD2694EDQ-TR](#) [KTZ8864EJAA-TR](#) [IS32LT3174-GRLA3-TR](#) [ZXLD1374QESTTC](#) [MP2488DN-](#)
[LF-Z](#) [NLM0010XTSA1](#) [AL1676-20BS7-13](#) [MPQ7220GF-AEC1-P](#) [MPQ7220GF-AEC1-Z](#) [MPQ4425BGJ-AEC1-Z](#) [IS31FL3737B-QFLS4-](#)
[TR](#) [IS31FL3239-QFLS4-TR](#) [KTD2058EUAC-TR](#) [KTD2037EWE-TR](#) [DIO5662ST6](#) [IS31BL3508A-TTLS2-TR](#) [MAX20052CATC/V+](#)
[MAX25606AUP/V+](#) [BD6586MUV-E2](#) [BD9206EFV-E2](#) [BD9416FS-E2](#) [LYT4227E](#) [LYT6079C-TL](#) [MP3394SGF-P](#) [MP4689AGN-P](#)
[MPQ4425AGQB-AEC1-Z](#)