

IS32LT3140A

SINGLE CHANNEL 450mA LED DRIVER WITH THERMAL SHUNT RESISTOR AND SINGLE LED SHORT DETECTION

June 2021

GENERAL DESCRIPTION

The IS32LT3140A is an automotive-grade high-side programmable current regulator consisting of a single output channel capable of 450mA. An external resistor sets the current level for the single-channel current source. An optional thermal shunt resistor can be used to significantly optimize IC power dissipation. It features an EN pin to enable or shutdown the device. It supports either PWM dimming via a PWM pin or power supply modulation (PSM). A resistor divider circuit can be used on the UV pin to set an external VCC under-voltage lockout threshold for LED string open and single LED short fault detection. In addition, the IS32LT3140A integrates fault protection for a single LED short, LED string open/short, output overcurrent (not reported), and over-temperature condition for robust operation. Detection of these failures is reported by the FAULTB pin. When a fault is detected the device will disable itself and output an active low open drain signal. Multiple devices can have their FAULTB pins connected to create a “one-fail-all-fail” condition.

The IS32LT3140A is targeted at the automotive market with end applications to include interior and exterior lighting. For 12V automotive applications, the low dropout driver can support one to several LEDs on the output channel. The device is offered in a small thermally enhanced eTSSOP-14 package.

FEATURES

- Wide input voltage range, 4.5V to 40V
- Single-channel sources up to 450mA
- High-side external resistor sets source current
- $\pm 8\%$ current accuracy over $-40^{\circ}\text{C} \sim +150^{\circ}\text{C}$
- Low headroom voltage, max 700mV at 150mA
- Low operating current of 350 μA and 5 μA in shutdown
- Optional thermal shunt resistor to optimize IC power dissipation
- Support for both PWM or PSM dimming
- Programmable VIN under-voltage lockout at PWM pin
- Fault protection with open-drain flag output:
 - Selectable fault actions
 - Single LED short
 - LED string open/short
 - Output overcurrent (not reported)
 - Thermal shutdown
- Shared fault flag for multiple device operation to comply with “one-fail-all-fail” function
- AEC-Q100 Qualified
- Operating temperature range from $-40^{\circ}\text{C} \sim +150^{\circ}\text{C}$

APPLICATIONS

- Automotive interior/exterior lighting:
 - Turn signal light
 - Rear lamp
 - Dome light

TYPICAL APPLICATION CIRCUIT

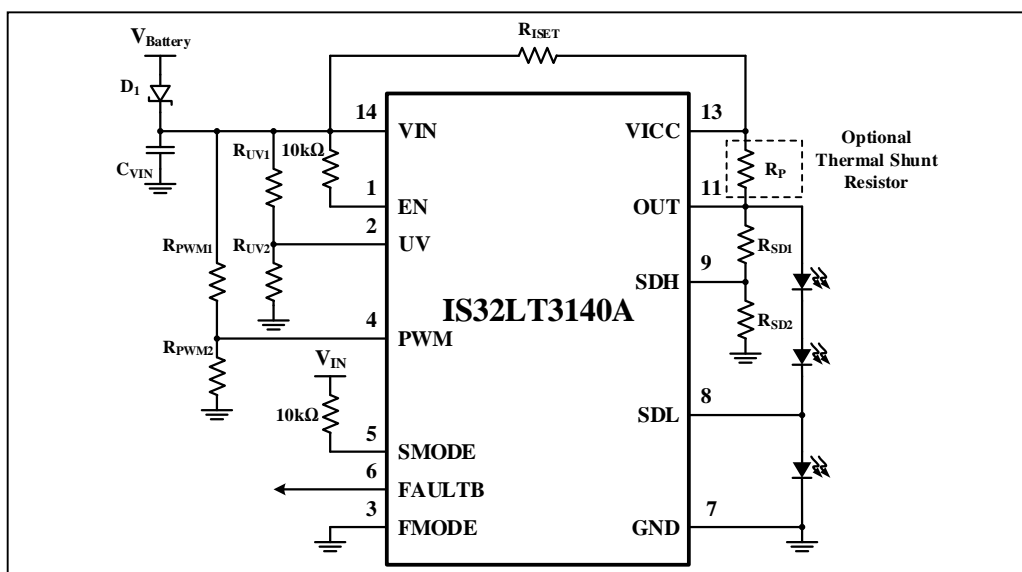

Figure 1 Typical Application Circuit (PSM Dimming Or Non-Dimming Applications)

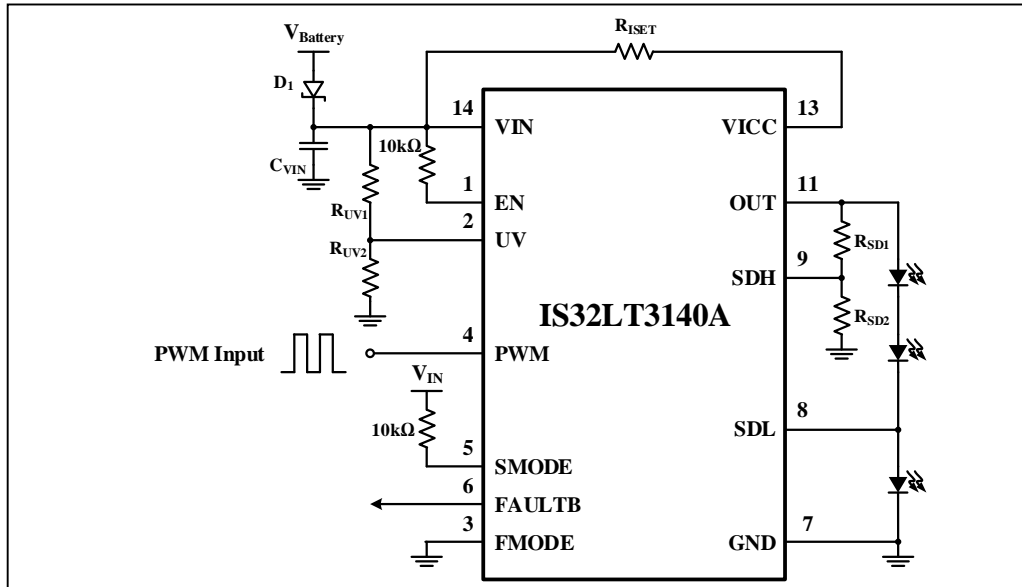

Figure 2 Typical Application Circuit with PWM Dimming

Note 1: For PSM dimming application, a high C_{VIN} capacitor value will affect the dimming accuracy. To get better dimming performance, recommend a value of $0.1\mu\text{F}$. If no PSM dimming requirement, C_{VIN} can be a larger value.

Note 2: The thermal shunt resistor R_P is only available for applications without EN shutdown, PWM dimming or “one fail all fail” mode fault protection.

Note 3: The current sense resistor R_{ISET} must be placed as close as possible to VIN and VICC pins on the PCB layout to avoid noise interference.

IS32LT3140A

PIN CONFIGURATION

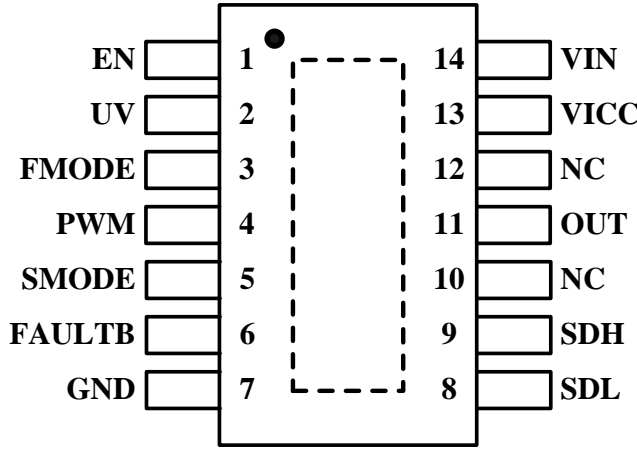
Package	Pin Configuration (Top View)
eTSSOP-14	

PIN DESCRIPTION

No.	Pin	Description
1	EN	Device enable pin. Internally pulled down to GND by a 4M Ω (Typ.) resistor. Pull low to shutdown the device. If unused, it must be connected to VIN pin via 10k Ω resistor.
2	UV	External under voltage lockout threshold setting for LED string open and signal LED short fault detection. Pull low will disable the LED open and single LED short fault detection. If unused, it must be connected to VIN pin via 10k Ω resistor.
3	FMODE	Fault mode set pin. Internally pulled down to GND by a 100k Ω (Typ.) resistor. Connect to VIN pin via a 10k Ω resistor to set high.
4	PWM	PWM dimming input. It also can be used for external VIN under voltage lockout threshold setting. If unused, it must be connected to VIN pin via 10k Ω resistor.
5	SMODE	Single LED short fault mode set pin. Internally pulled down to GND by a 100k Ω (Typ.) resistor. Connect it to VIN pin via a 10k Ω resistor to set high.
6	FAULTB	Open drain I/O diagnostic pin. Active low output driven by the device when it detects a fault condition. As an input (FMODE pin low), this pin will accept an externally generated FAULTB signal to disable the device output to satisfy the “one fail all fail” function. This pin is internally pulled up to internal 4.5V (Typ.) LDO by a 50k Ω (Typ.) resistor.
7	GND	Ground.
8	SDL	Single LED short low side detect reference.
9	SDH	Single LED short high side detect reference.
10,12	NC	Not connected.
11	OUT	Output current source channel.
13	VICC	Current input and current sense pin.
14	VIN	Power supply input and current sense pin.
	Thermal Pad	MUST be electrically connected to large GND plane for better thermal dissipation.

IS32LT3140A

ORDERING INFORMATION

Automotive Range: -40°C to +125°C

Order Part No.	Package	QTY/Reel
IS32LT3140A-ZLA3-TR	eTSSOP-14, Lead-free	2500

Copyright © 2021 Lumissil Microsystems. All rights reserved. Lumissil Microsystems reserves the right to make changes to this specification and its products at any time without notice. Lumissil Microsystems assumes no liability arising out of the application or use of any information, products or services described herein. Customers are advised to obtain the latest version of this device specification before relying on any published information and before placing orders for products.

Lumissil Microsystems does not recommend the use of any of its products in life support applications where the failure or malfunction of the product can reasonably be expected to cause failure of the life support system or to significantly affect its safety or effectiveness. Products are not authorized for use in such applications unless Lumissil Microsystems receives written assurance to its satisfaction, that:

- a.) the risk of injury or damage has been minimized;
- b.) the user assume all such risks; and
- c.) potential liability of Lumissil Microsystems is adequately protected under the circumstances

IS32LT3140A

ABSOLUTE MAXIMUM RATINGS

All pins voltage	-0.3V ~ +45V
VIN pin to VICC pin voltage, $V_{IN} - V_{VICC}$	-0.3V ~ +1V
Operating temperature, $T_A = T_J$	-40°C ~ +150°C
Maximum continuous junction temperature, $T_{J(MAX)}$	+150°C
Storage temperature range, T_{STG}	-65°C ~ +150°C
Package thermal resistance, junction to ambient (4 layer standard test PCB based on JEDEC standard), θ_{JA}	45.5°C/W
Package thermal resistance, junction to thermal PAD (4 layer standard test PCB based on JEDEC standard), θ_{JP}	1.61°C/W
Maximum power dissipation, P_{DMAX}	2.75W
ESD (HBM)	±2kV
ESD (CDM)	±750V

Note 4: Stresses beyond those listed under “Absolute Maximum Ratings” may cause permanent damage to the device. These are stress ratings only and functional operation of the device at these or any other condition beyond those indicated in the operational sections of the specifications is not implied. Exposure to absolute maximum rating conditions for extended periods may affect device reliability.

ELECTRICAL CHARACTERISTICS

$T_J = T_A = -40^\circ\text{C} \sim +150^\circ\text{C}$, $V_{IN} = 12\text{V}$, the detail refer to each condition description, unless otherwise noted. Typical values are at $T_J = T_A = 25^\circ\text{C}$ (Note 5).

Symbol	Parameter	Conditions	Min.	Typ.	Max.	Unit
Power Up Parameter						
V_{IN}	Supply voltage range		4.5		40	V
V_{UVLO_R}	VIN under voltage lockout rising threshold			3.2	4.0	V
V_{UVLO_F}	VIN under voltage lockout falling threshold		2.2	3.0		V
I_{IN}	VIN quiescent current	$V_{PWM} = \text{High}$, $V_{EN} = \text{High}$, no fault conditions	0.2	0.35	0.6	mA
I_{SD}	Shutdown current	$V_{EN} = \text{Low}$		5	10	μA
I_{IN_FLT}	VIN supply current in fault condition	$V_{PWM} = \text{High}$, $V_{EN} = \text{High}$, $V_{MODE} = \text{Low}$, $V_{UV} = \text{High}$, FAULTB externally pulled low	0.3	0.4	0.6	mA
t_{ON}	EN high time for IC power up	$I_{OUT} = -150\text{mA}$, $V_{IN} = 12\text{V}$, $V_{EN} = \text{High}$	20	40	60	μs
Channel Parameter						
I_{OUT_R}	Channel output current range	100% duty cycle	-450		-4	mA
V_{SENSE}	Current sense voltage ($V_{IN} - V_{VICC}$)	$V_{IN} = 4.5\text{V to }18\text{V}$, $T_J = T_A = 25^\circ\text{C}$	96	101	106	mV
		$V_{IN} = 4.5\text{V to }18\text{V}$, $T_J = T_A = -40^\circ\text{C} \sim +150^\circ\text{C}$	93	101	109	mV
V_{HR_MIN}	Minimum headroom voltage, from VIN to OUT (V_{SENSE} included)	$I_{OUT} = -10\text{mA}$		120	150	mV
		$I_{OUT} = -70\text{mA}$		250	400	
		$I_{OUT} = -150\text{mA}$		430	700	
		$I_{OUT} = -300\text{mA}$		800	1300	
I_{OUT_L}	Output limit current	VIN shorted to VICC, $V_{HR} = 3\text{V}$		-600		mA
I_{LEAK}	Channel leakage current	$V_{EN} = \text{Low}$, $V_{OUT} = 0\text{V}$			1	μA
		$V_{PWM} = \text{Low}$, $V_{EN} = \text{High}$, $V_{OUT} = 0\text{V}$			1	μA

IS32LT3140A

ELECTRICAL CHARACTERISTICS (CONTINUE)

$T_J = T_A = -40^{\circ}\text{C} \sim +150^{\circ}\text{C}$, $V_{IN} = 12\text{V}$, the detail refer to each condition description, unless otherwise noted. Typical values are at $T_J = T_A = 25^{\circ}\text{C}$ (Note 5).

Symbol	Parameter	Conditions	Min.	Typ.	Max.	Unit
t _{SL}	Current rising/falling slew time	Enabled/disabled by PWM pin, current rise/fall between 10%~90%, I _{OUT} = -300mA	8	16	24	μs
Fault Protect Parameter						
t _{FD_DT}	Fault detect deglitch time (except single LED short)	*Fault must be present at least this long to trigger the fault detect	70	130	190	μs
t _{FD_SS}	Single LED short fault detect deglitch time	*Fault must be present at least this long to trigger the fault detect	100	200	300	μs
t _{FD_RL}	Fault release deglitch time		30	60	90	μs
V _{FAULTB_PU}	FAULTB pin internally pull-up voltage		4		5.5	V
R _{FAULTB}	FAULTB pin pull-up resistor			50		kΩ
V _{FAULTB_PD}	FAULTB pin externally pull-down voltage	Sink current= 5mA		0.2	0.4	V
V _{FAULTB_IH}	FAULTB pin input high enable threshold	V _{FMODE} = Low	2			V
V _{FAULTB_IL}	FAULTB pin input low disable threshold	V _{FMODE} = Low			0.7	V
V _{SCD_R}	OUT pin short to GND rising threshold	Measured at OUT pin	1.1	1.2	1.3	V
V _{SCD_F}	OUT pin short to GND falling threshold	Measured at OUT pin	0.82	0.865	0.91	V
V _{OD_R}	OUT pin open rising threshold	Measured at (V _{VI} CC-V _{OUT})	70	120	160	mV
V _{OD_F}	OUT pin open falling threshold	Measured at (V _{VI} CC-V _{OUT})	250	320	400	mV
V _{SSH_TH}	Single LED short detection high side threshold	Measured at (V _{SDL} -V _{SDH})	200	230	260	mV
V _{SSL_TH}	Single LED short detection low side threshold	Measured at SDL pin, voltage falling	0.80	0.86	0.91	V
V _{SSL_HY}	Single LED short detection low side threshold hysteresis	Measured at SDL pin	40	80	110	mV
I _{RTR}	Output retry current in fault modes	V _{OUT} = 0V	-1.6	-1	-0.6	mA
T _{SD}	Thermal shutdown threshold	(Note 6)		175		°C
T _{HY}	Over-temperature hysteresis	(Note 6)		25		°C

IS32LT3140A

ELECTRICAL CHARACTERISTICS (CONTINUE)

$T_J = T_A = -40^{\circ}\text{C} \sim +150^{\circ}\text{C}$, $V_{IN} = 12\text{V}$, the detail refer to each condition description, unless otherwise noted. Typical values are at $T_J = T_A = 25^{\circ}\text{C}$ (Note 5).

Symbol	Parameter	Conditions	Min.	Typ.	Max.	Unit
Logic Input						
V_{IH}	EN, FMODE, SMODE pins input logic high voltage		2.0			V
V_{IL}	EN, FMODE, SMODE pins input logic low voltage				0.7	V
V_{UV_IH}	UV input rising threshold		1.14	1.20	1.3	V
V_{UV_IL}	UV input falling threshold		1.045	1.1	1.155	V
V_{PWM_IH}	PWM input rising threshold		1.14	1.20	1.3	V
V_{PWM_IL}	PWM input falling threshold		1.045	1.1	1.155	V
f_{PWM}	PWM frequency to PWM pin				1	kHz
t_{PWM_R}	Delay time of PWM rising edge to 10% output current	$I_{OUT} = -100\text{mA}$	10	17	25	μs
t_{PWM_F}	Delay time of PWM falling edge to 90% output current	$I_{OUT} = -100\text{mA}$	15	21	30	μs
R_{PD_MODE}	FMODE and SMODE pins internal pull-down resistor			100		k Ω
R_{PD_EN}	EN pin internal pull-down resistor			4		M Ω

Note 5: Limits are 100% production tested at 25°C. Limits over the operating temperature range verified through either bench and/or tester testing and correlation using Statistical methods.

Note 6: Guaranteed by design.

IS32LT3140A

FUNCTIONAL BLOCK DIAGRAM

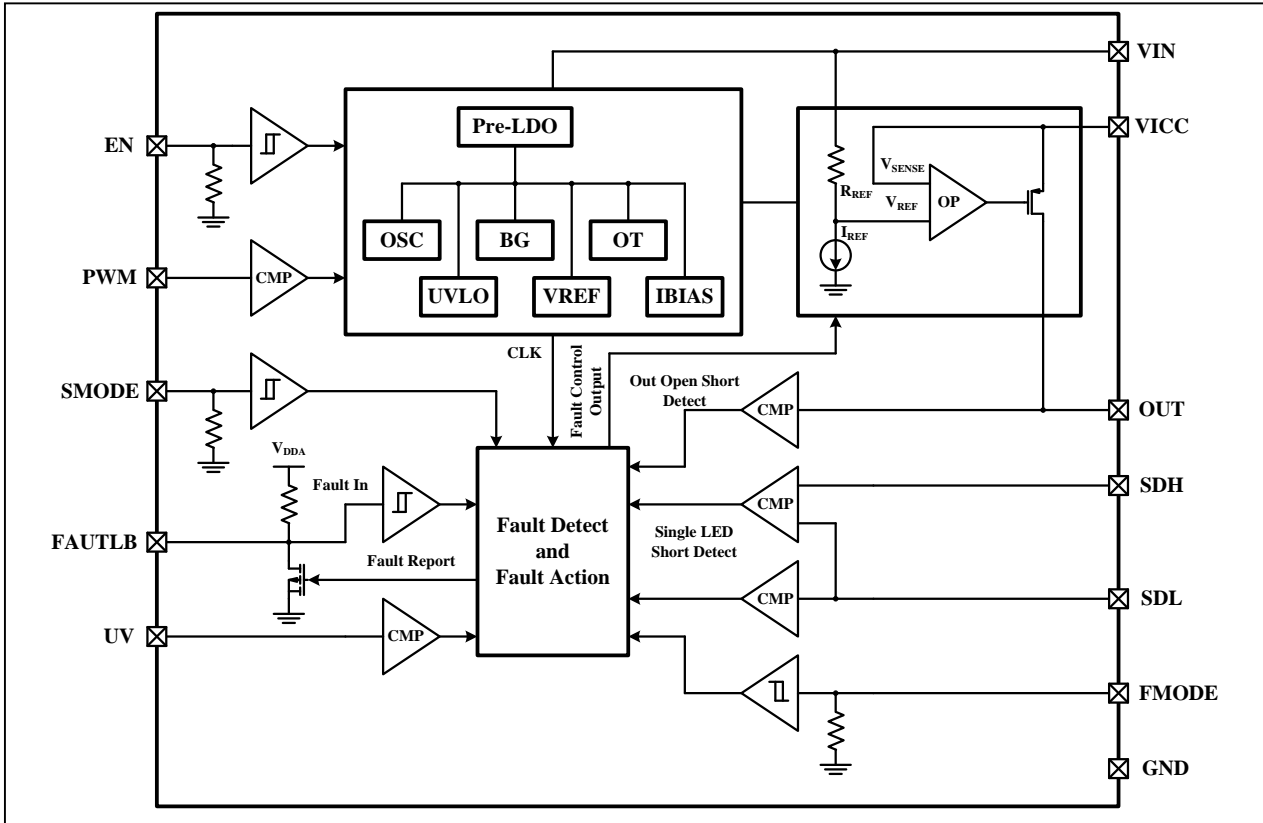

IS32LT3140A

TYPICAL PERFORMANCE CHARACTERISTICS

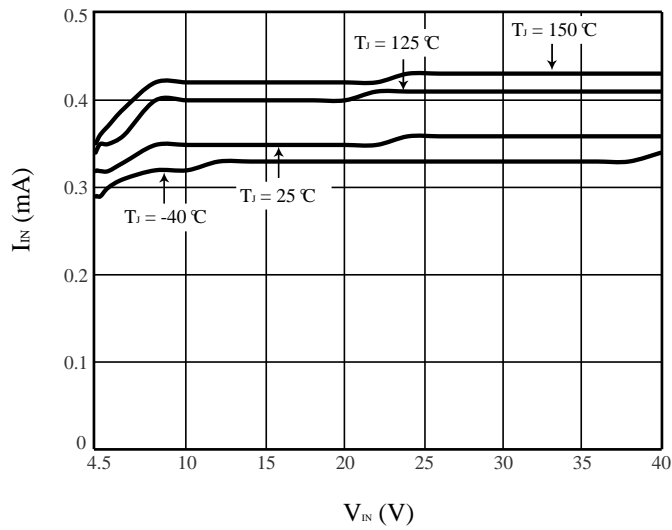

Figure 3 I_{IN} vs. V_{IN}

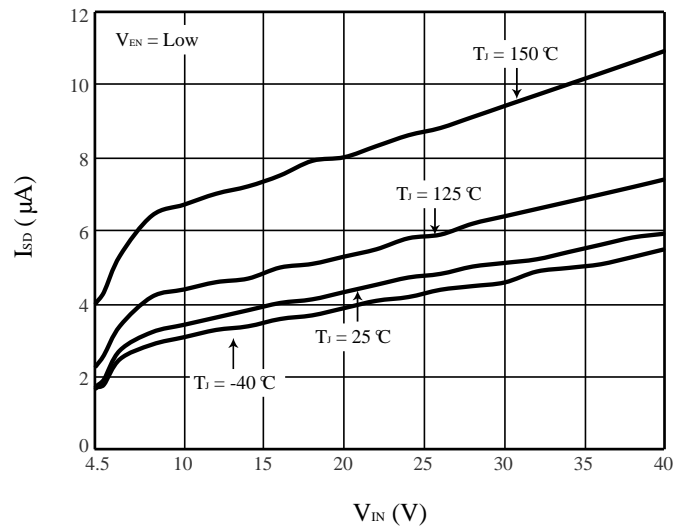

Figure 4 I_{SD} vs. V_{IN}

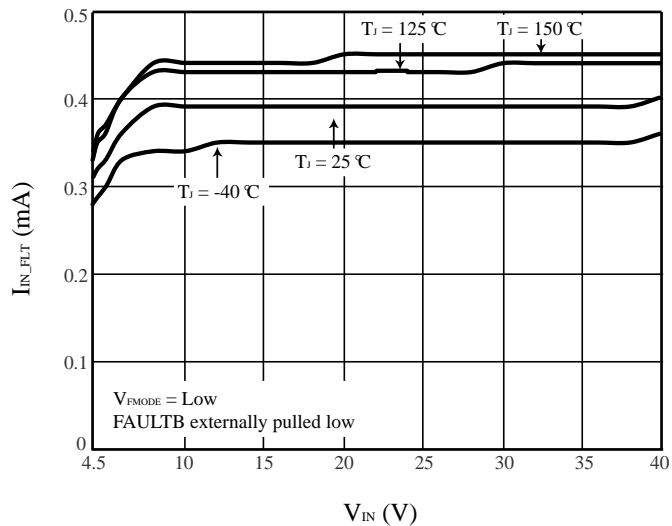

Figure 5 I_{IN_FLT} vs. V_{IN}

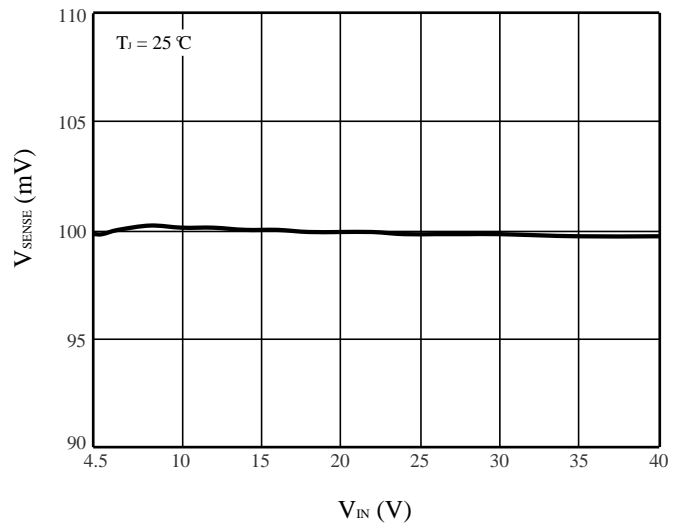

Figure 6 V_{SENSE} vs. V_{IN}

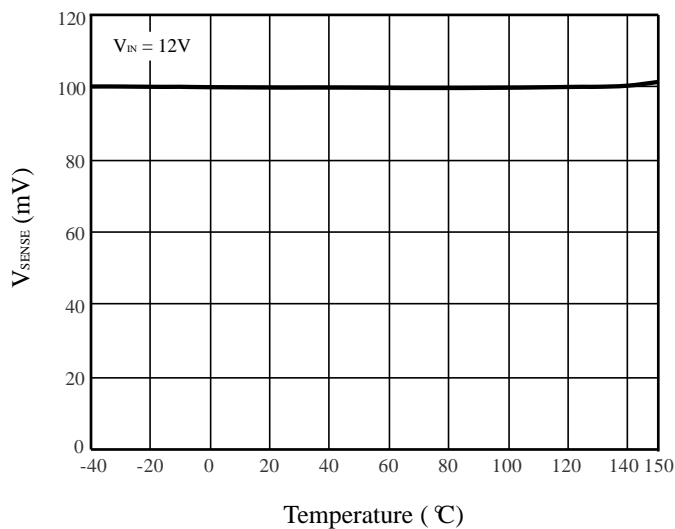

Figure 7 V_{SENSE} vs. T_J

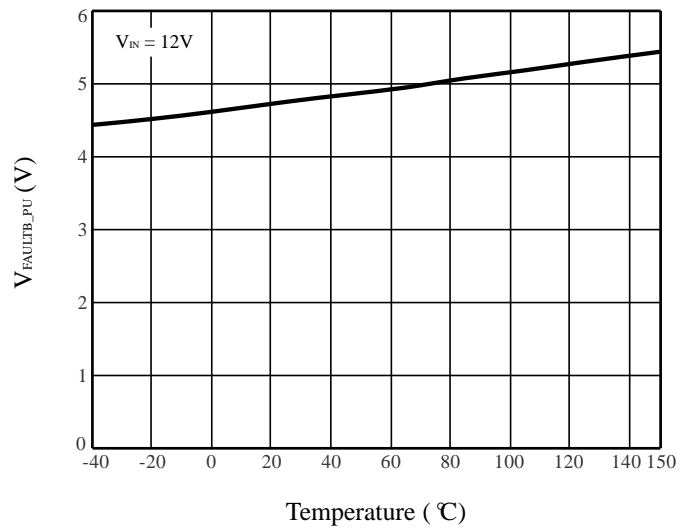

Figure 8 V_{FAULTB_PU} vs. T_J

IS32LT3140A

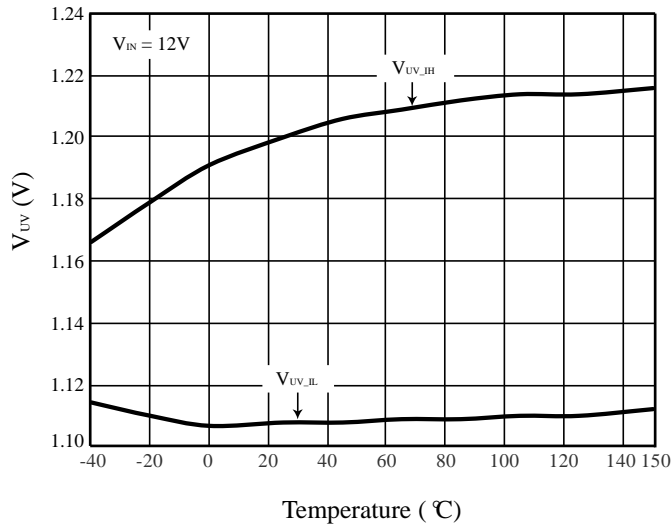

Figure 9 V_{UV} vs. T_J

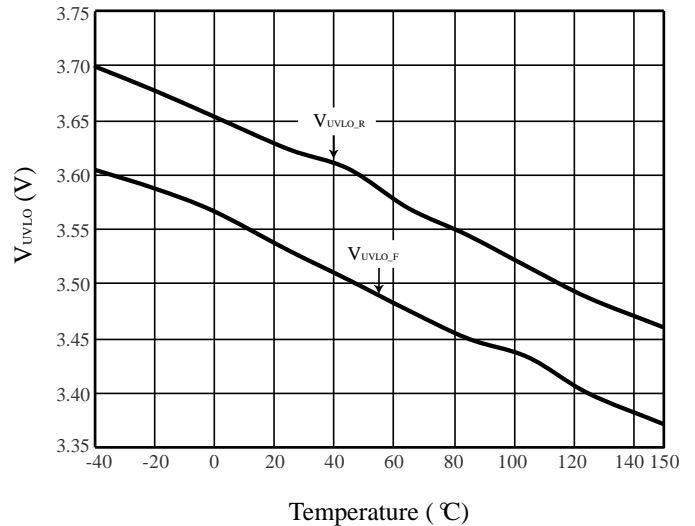

Figure 10 V_{UVLO} vs. T_J

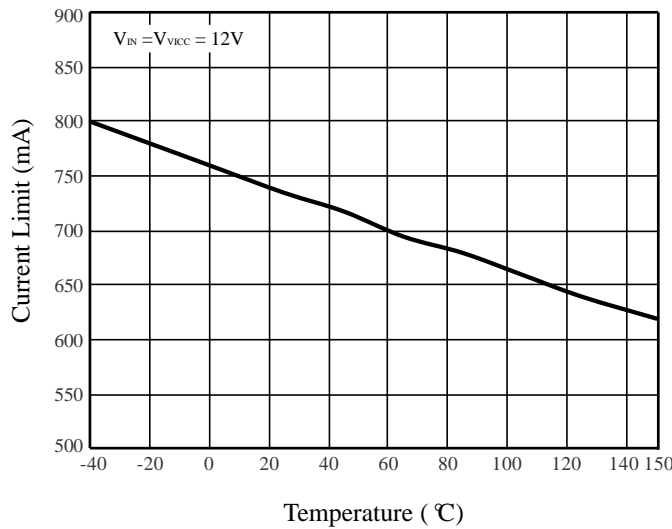

Figure 11 I_{OUT,L} vs. T_J

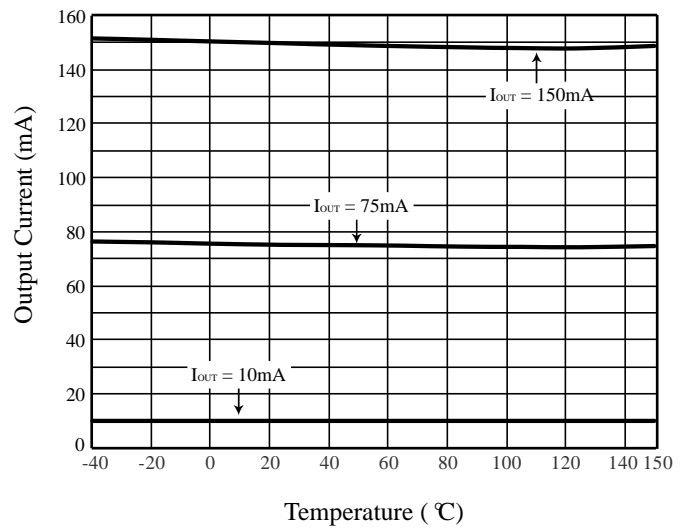

Figure 12 I_{OUT} vs. T_J

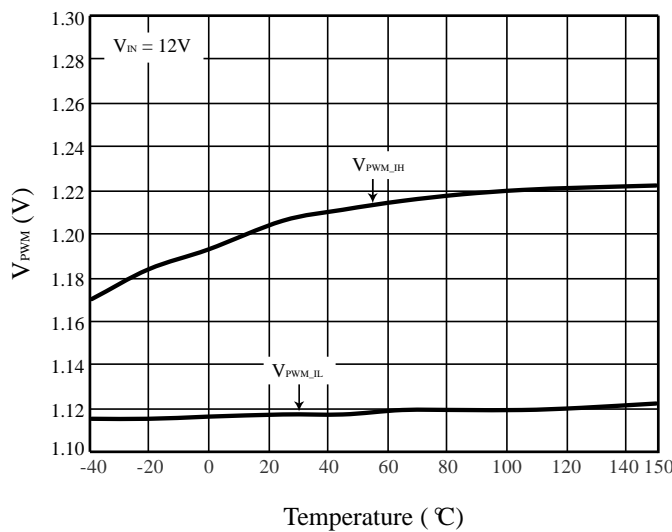

Figure 13 PWM Threshold vs. T_J

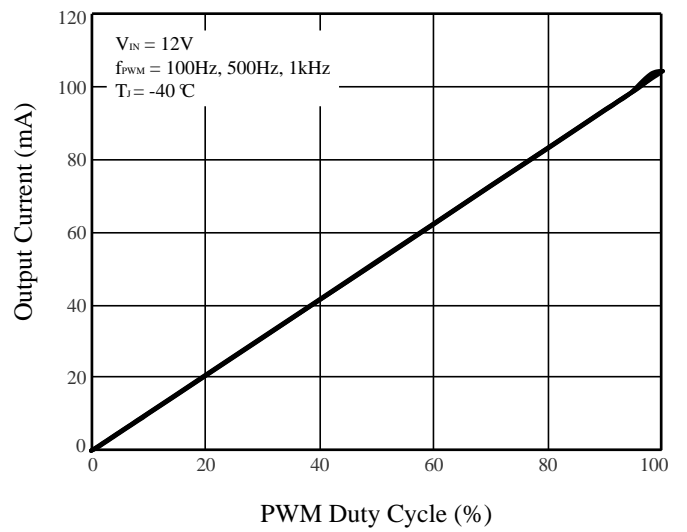

Figure 14 Output Current vs. PWM Duty Cycle

IS32LT3140A

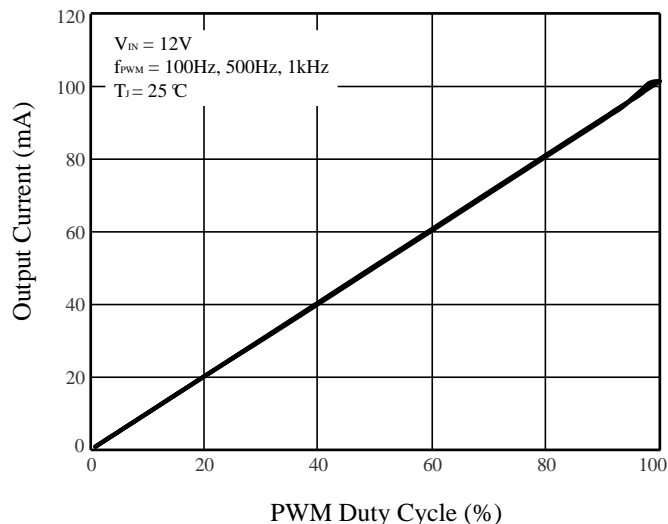

Figure 15 Output Current vs. PWM Duty Cycle

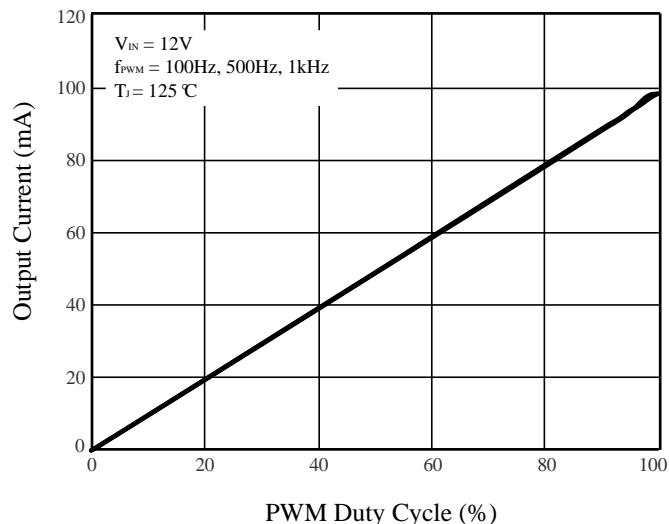

Figure 16 Output Current vs. PWM Duty Cycle

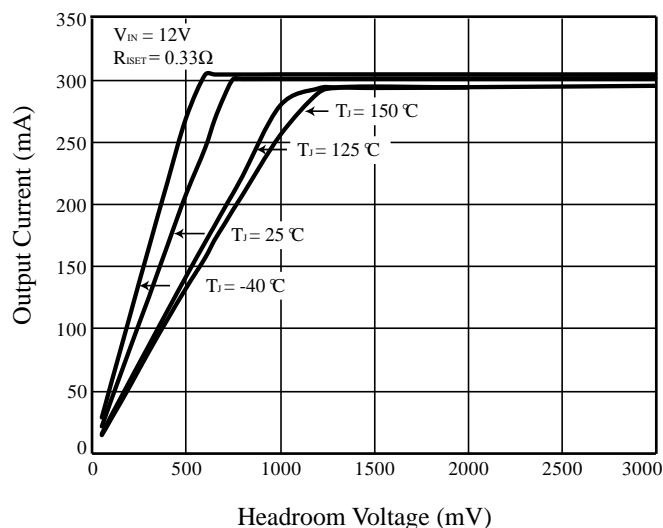

Figure 17 Output Current vs. Headroom Voltage

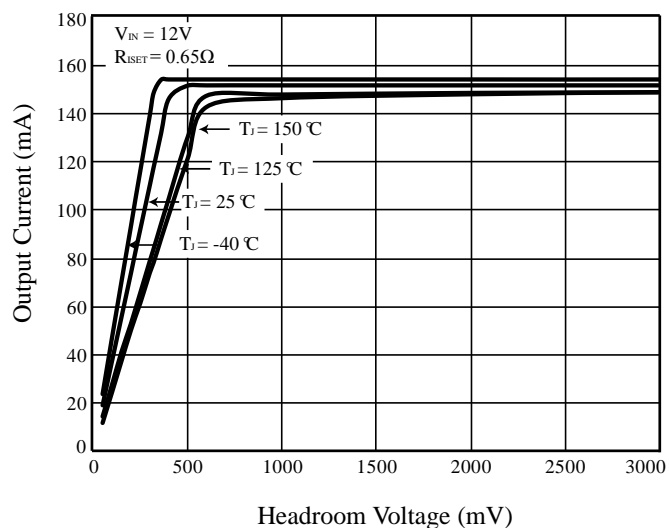

Figure 18 Output Current vs. Headroom Voltage

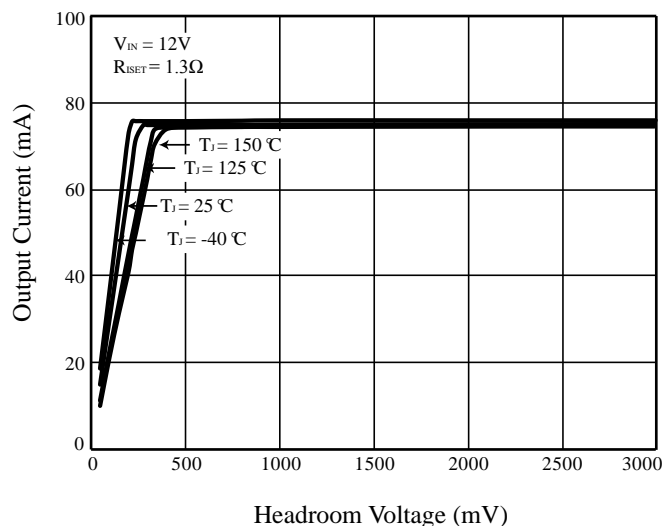

Figure 19 Output Current vs. Headroom Voltage

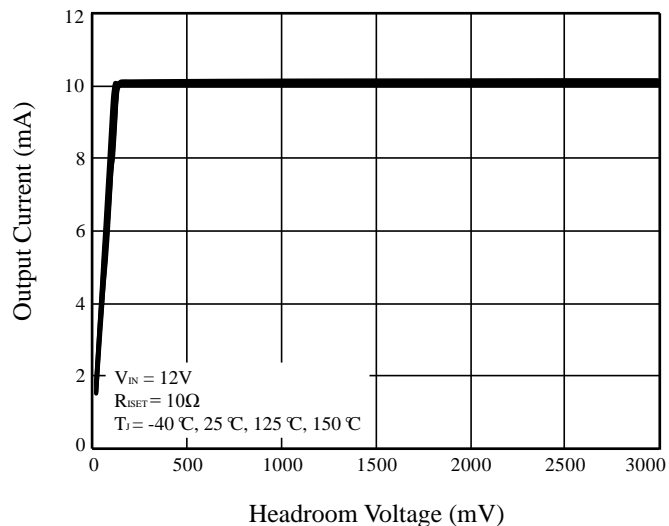

Figure 20 Output Current vs. Headroom Voltage

IS32LT3140A

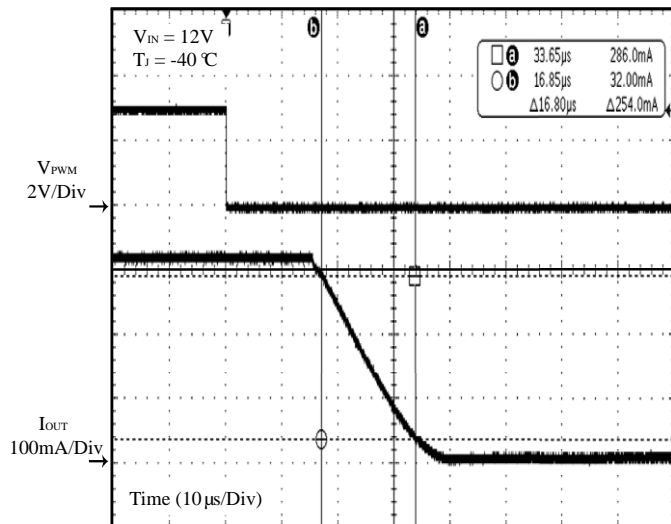

Figure 21 PWM Off

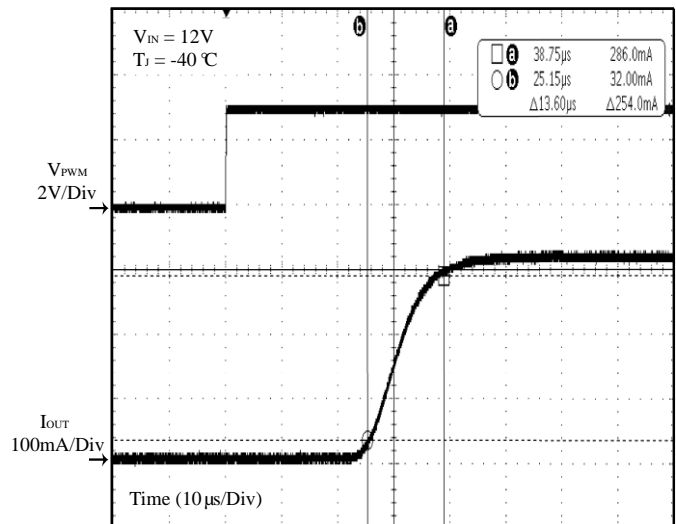

Figure 22 PWM On

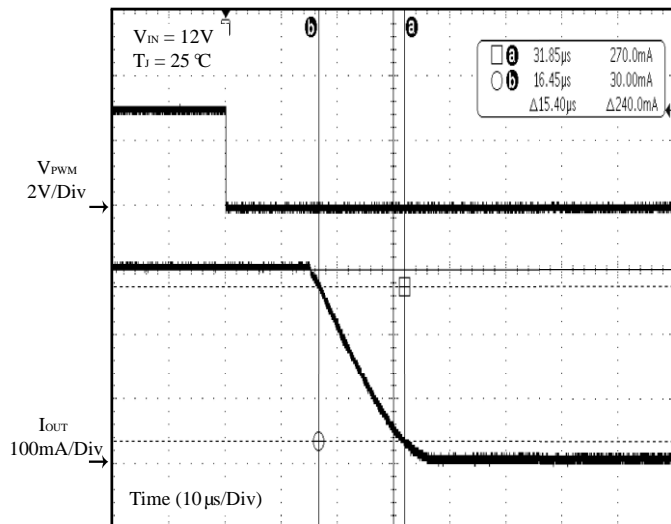

Figure 23 PWM Off

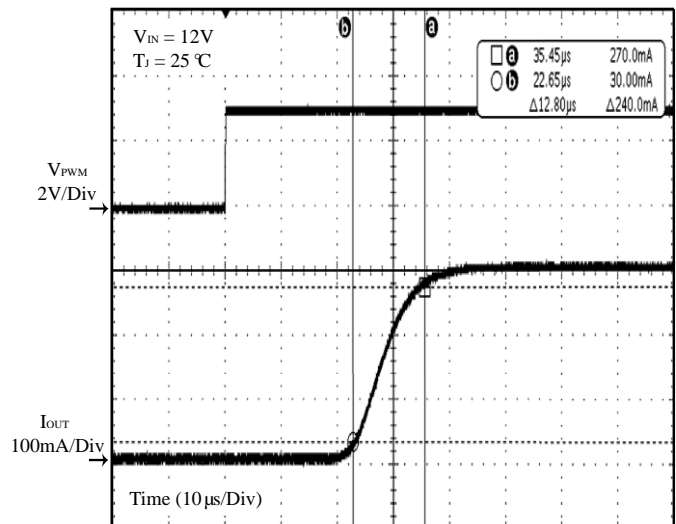

Figure 24 PWM On

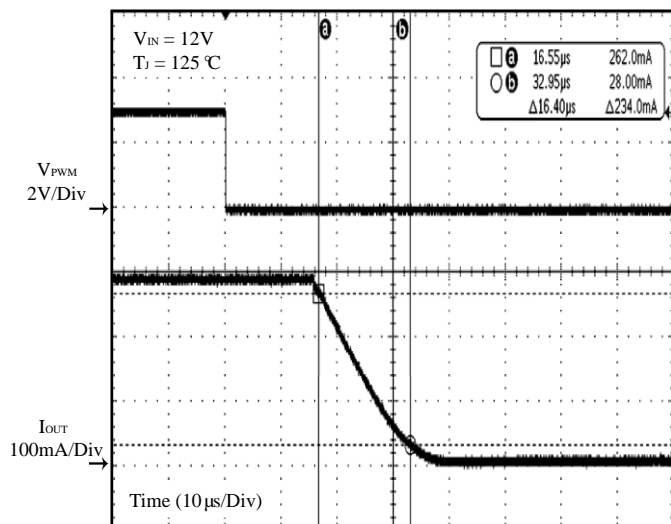

Figure 25 PWM Off

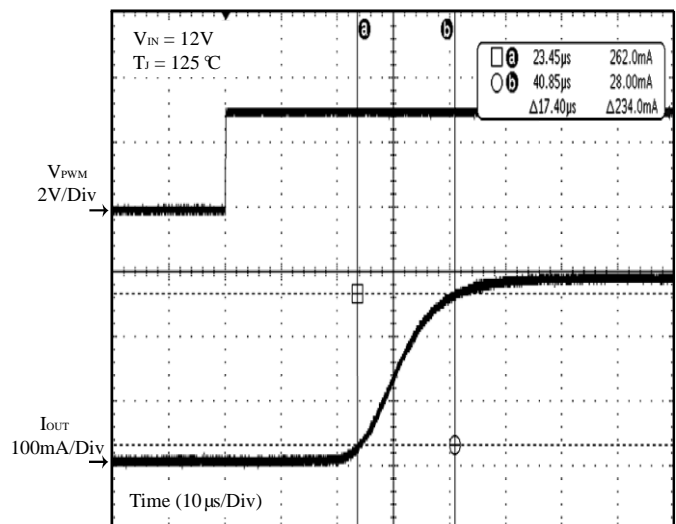

Figure 26 PWM On

IS32LT3140A

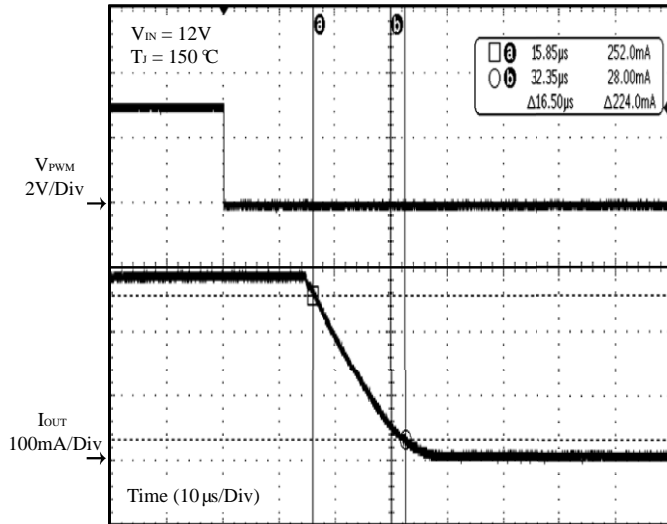

Figure 27 PWM Off

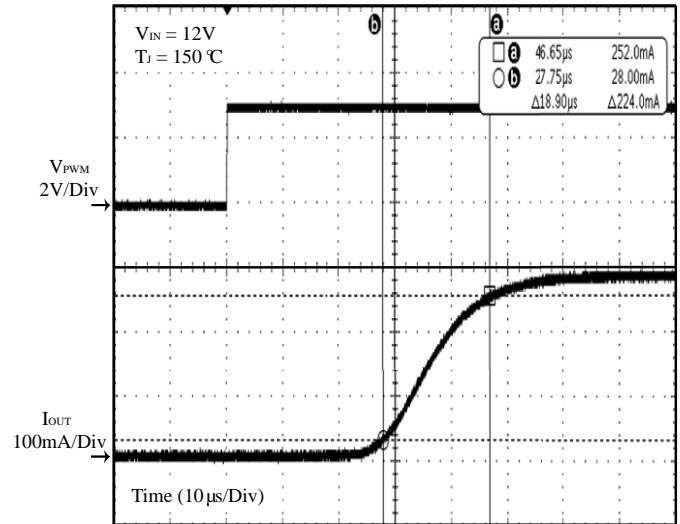

Figure 28 PWM On

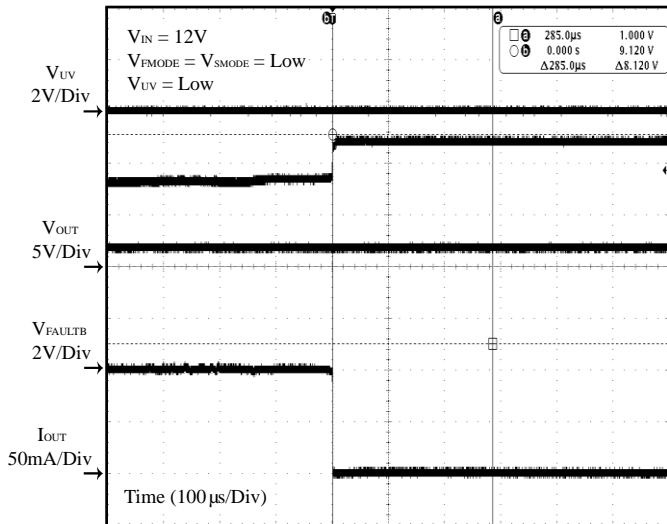

Figure 29 Output Open

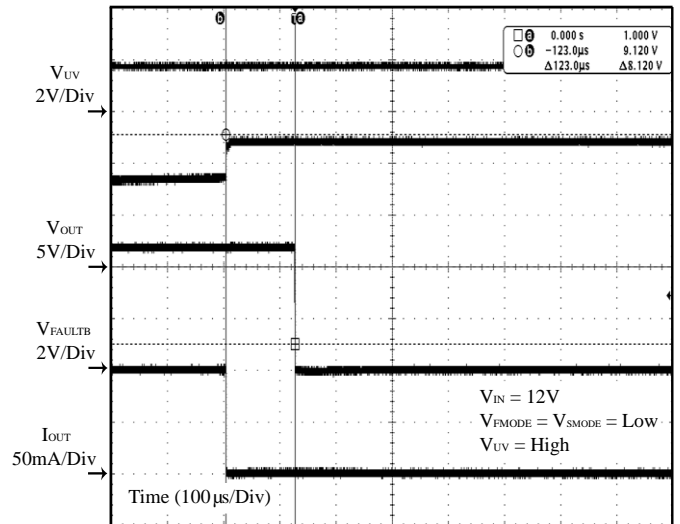

Figure 30 Output Open

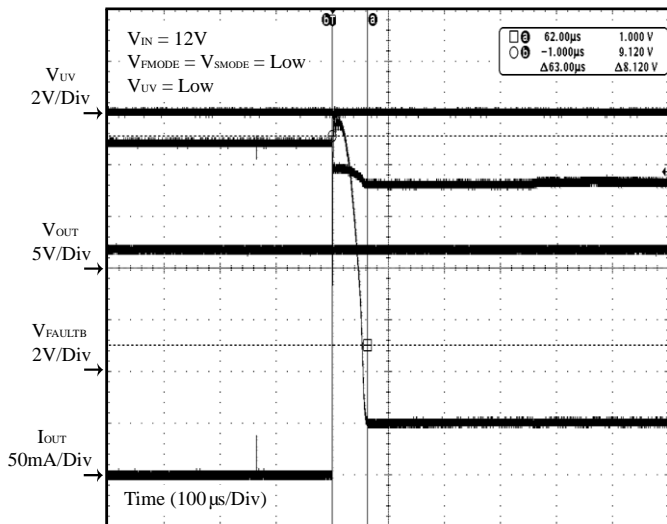

Figure 31 Output Open Fault Remove

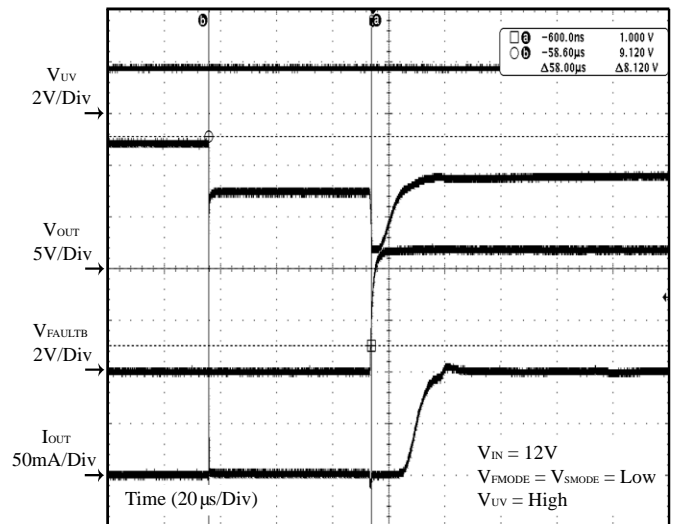

Figure 32 Output Open Fault Remove

IS32LT3140A

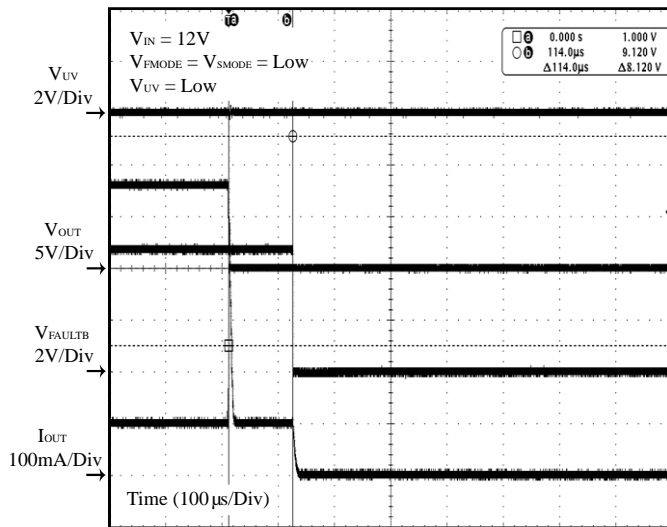

Figure 33 Output Short

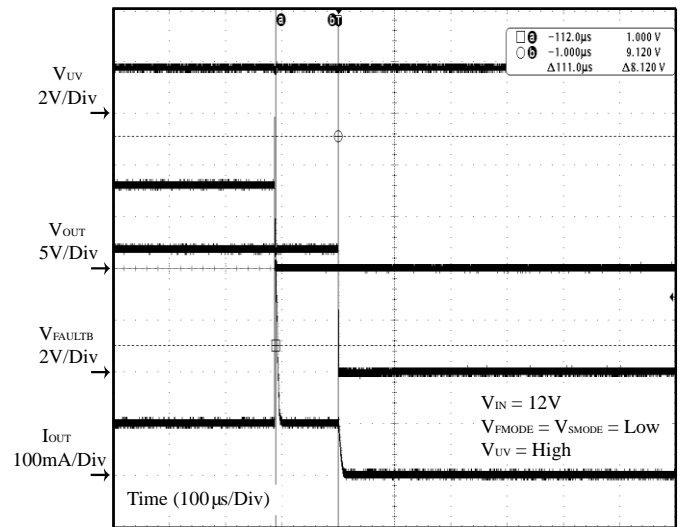

Figure 34 Output Short

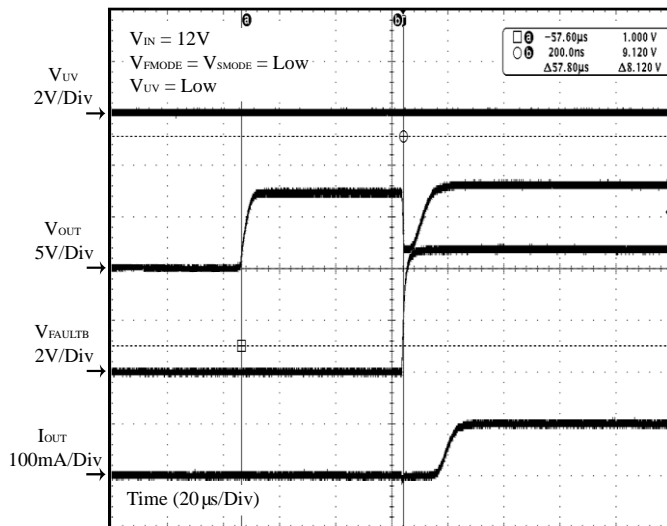

Figure 35 Output Short Fault Remove

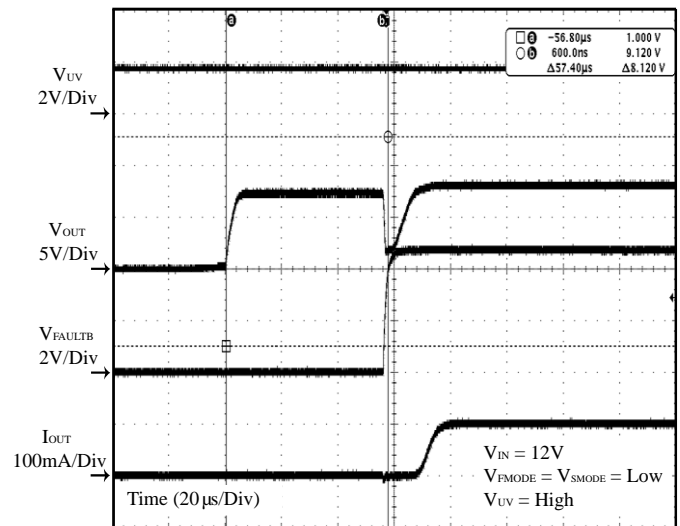

Figure 36 Output Short Fault Remove

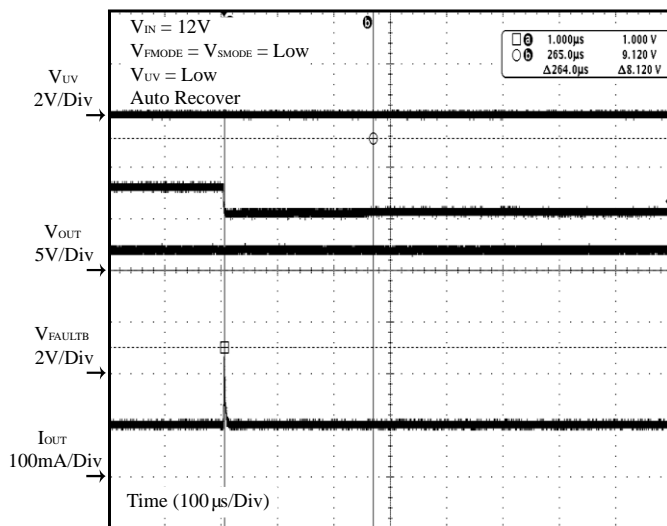

Figure 37 Single LED Short (Auto Recover)

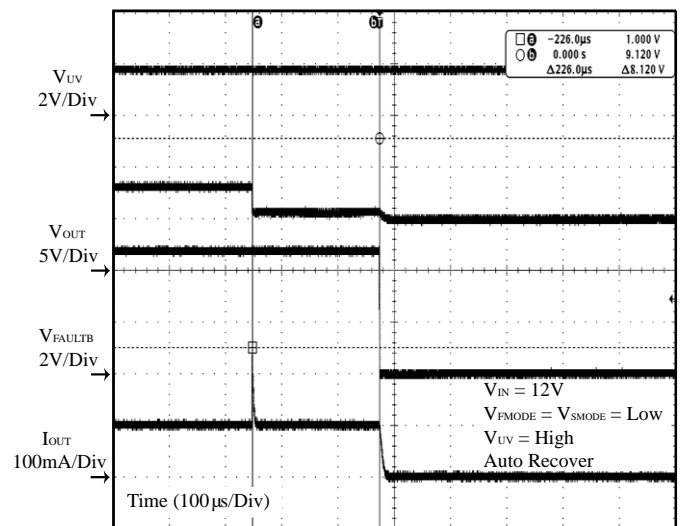

Figure 38 Single LED Short (Auto Recover)

IS32LT3140A

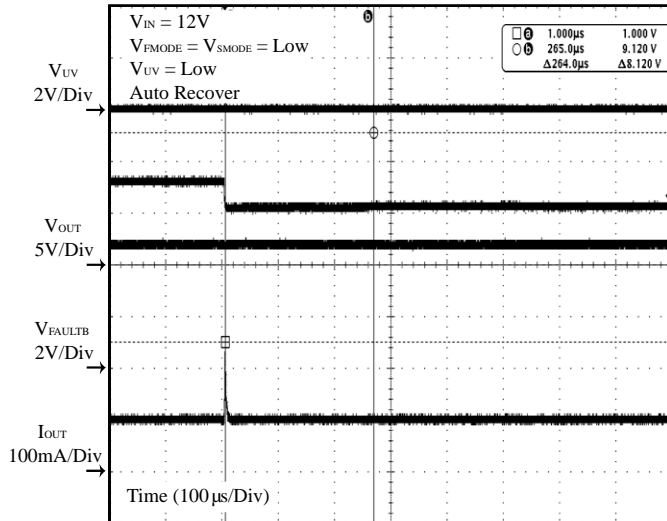

Figure 39 Single LED Short Remove (Auto Recover)

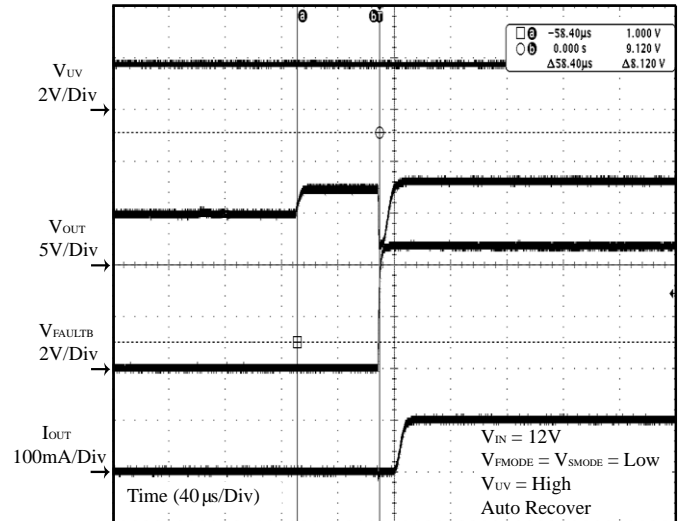

Figure 40 Single LED Short Remove (Auto Recover)

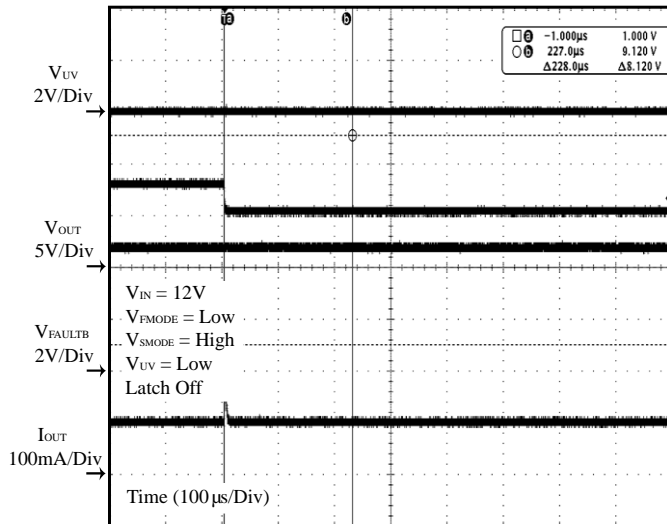

Figure 41 Single LED Short (Latch Off)

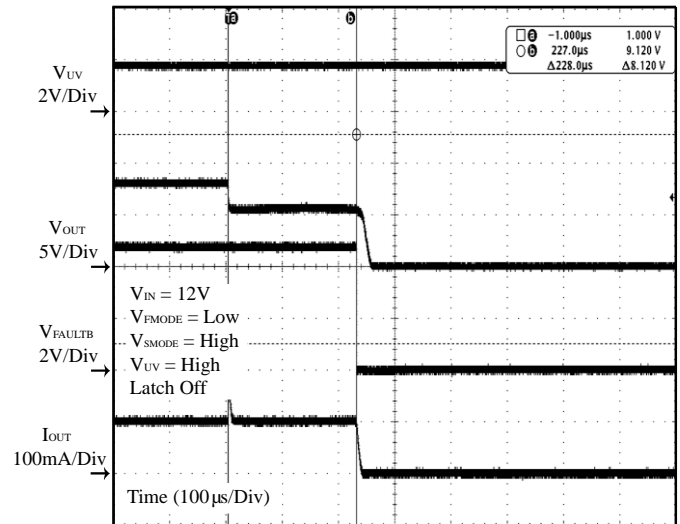

Figure 42 Single LED Short (Latch Off)

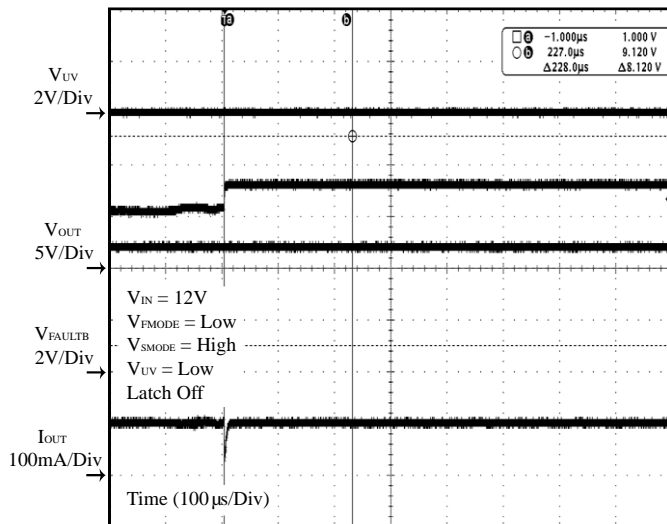

Figure 43 Single LED Short Remove (Latch Off)

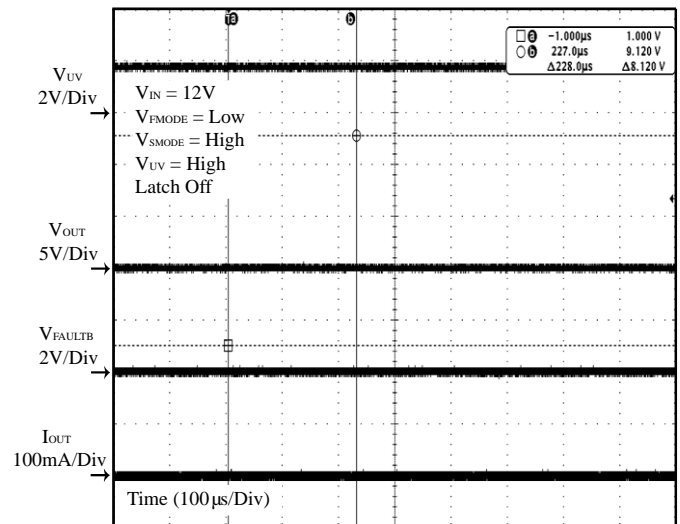

Figure 44 Single LED Short Remove (Latch Off)

IS32LT3140A

APPLICATION INFORMATION

The IS32LT3140A is a programmable linear current source capable of regulating a constant current up to 450mA. A single resistor R_{ISET} is connected across the VIN and VICC pins to set the output current value. The current flows from the power supply through the R_{ISET} resistor into the VICC pin and internal current source and out from OUT pin to LED string. The device senses the voltage drop on the R_{ISET} resistor and an internal regulation loop drives the output current source to regulate the voltage drop on the R_{ISET} resistor at V_{SENSE} .

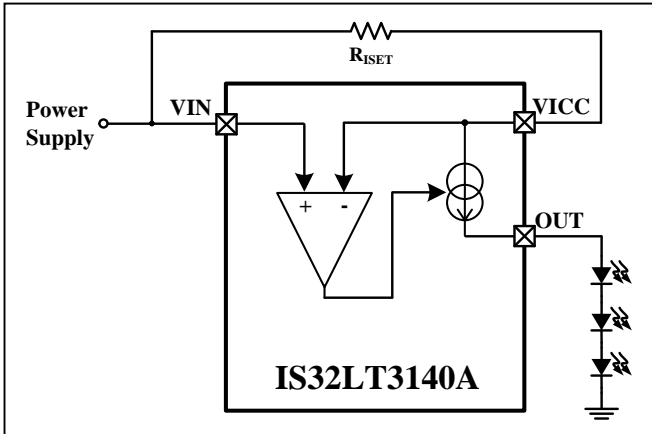

Figure 45 Constant Current Regulation

OUTPUT CURRENT SETTING

The regulated maximum LED current is set by the current sense resistor R_{ISET} . The R_{ISET} resistor value can be calculated using the following equation:

$$R_{ISET} = \frac{V_{SENSE}}{I_{LED}} \quad (1)$$

Where I_{LED} is the desired LED current in Amp and R_{ISET} is in Ω . V_{SENSE} is current sense voltage, 0.1V typical.

It is recommend that R_{ISET} be a 1% accuracy resistor with good temperature characteristic to ensure stable and precise output current. On the PCB layout, this resistor must be placed as close to VIN pin and VICC pin as possible to avoid noise interference.

When the desired current is high, the power rating also should be considered. The maximum power dissipation on the R_{ISET} resistor is calculated by:

$$P_{R_{ISET}} = V_{SENSE} \times I_{LED} \quad (2)$$

A single high wattage resistor or several small wattage resistors in parallel can be used to sustain the power dissipation.

The device is protected from an output overcurrent condition caused by R_{ISET} resistor. The output current is limited to an I_{OUT_L} value of 600mA for if a low value resistor is connected to VIN and VICC pins.

DEVICE ENABLE AND SHUTDOWN

The EN pin is an enable input for the device, pull it higher than V_{IH} to enable the device; pull it lower than V_{IL} to force the device into shutdown mode with an ultralow quiescent current. If the shutdown mode is unused, connect the EN pin to the VIN pin via a 10k Ω resistor.

PWM DIMMING

PWM pin controls the current source output source. The PWM pin voltage should be higher than V_{PWM_IH} to enable the output source and lower than V_{PWM_IL} to disable it. Note that the output fault detection is also disabled when the PWM pin is low.

An external PWM signal on the PWM pin can be used to modulate the output current to dim the LED light output.. The PWM dimming LED current is based on the PWM signal's duty cycle and can be calculated by the following Equation:

$$I_{LED_PWM} = I_{LED} \times D_{PWM} \quad (3)$$

Where D_{PWM} is the duty cycle of PWM signal.

The recommended frequency range of the external PWM signal is 100Hz~1kHz and the duty cycle can be from 0 to 100%. Due to the output's current slew rate control for EMI consideration plus the propagation time from PWM rising edge to the output activity, a lower frequency PWM will provide a better dimming contrast ratio.

UNDER VOLTAGE LOCKOUT (UVLO)

IS32LT3140A features an under voltage lockout (UVLO) function on the VIN pin to prevent misoperation at low input voltages. The UVLO threshold is an internally fixed value and cannot be adjusted. The device is enabled when the V_{IN} voltage exceeds V_{UVLO_R} (Typ. 3.2V), and disabled when the V_{IN} voltage falls below V_{UVLO_F} (Typ. 3.0V).

Besides this internal, fixed UVLO, it may be desirable to externally set a higher UVLO threshold for some applications. A precise UVLO threshold voltage can be set by using a resistor voltage divider between VIN and Gnd with the center connected to the PWM pin.

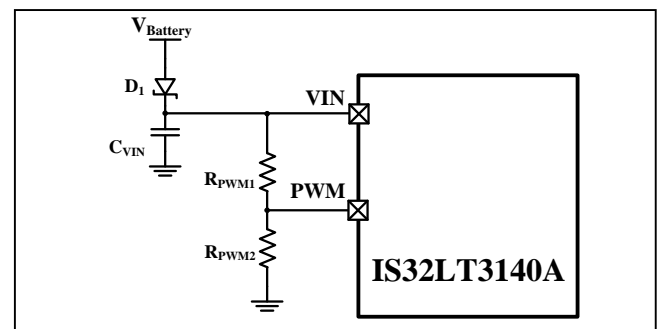

Figure 46 External UVLO for VIN

IS32LT3140A

The external UVLO threshold voltage can be computed by the following Equations:

$$V_{UVLO_EXTF} = V_{PWM_IL} \times \frac{R_{P_{PWM1}} + R_{P_{PWM2}}}{R_{P_{PWM2}}} \quad (4)$$

$$V_{UVLO_EXTR} = V_{PWM_IH} \times \frac{R_{P_{PWM1}} + R_{P_{PWM2}}}{R_{P_{PWM2}}} \quad (5)$$

The output source is enabled when the V_{IN} voltage exceeds V_{UVLO_EXTR} , and disabled when the V_{IN} voltage falls below V_{UVLO_EXTF} .

It is recommended that $R_{P_{PWM1}}$ and $R_{P_{PWM2}}$ be 1% accuracy resistors with good temperature characteristics to ensure a precise detection. On the PCB layout, this resistor divider must be placed as close as possible to the PWM pin to avoid noise coupling into the UVLO detection.

The PWM pin is a high impedance input. If the PWM pin is unused, connect it to the VIN pin using a 10kΩ resistor.

POWER SUPPLY MODULATION (PSM) DIMMING

The IS32LT3140A can support Power Supply Modulation (PSM), which implements LED dimming by pulse width modulation of the power supply rail. The IS32LT3140A's closed loop stability is not affected by PSM operation. To get better dimming linearity, the recommended PSM frequency should be in the range of 100Hz to 300Hz (200Hz Typ.) and the input capacitor, C_{VIN} , should be of a low value (0.1uF Typ.) to ensure rapid discharge during PSM low periods. In PSM dimming applications, the external UVLO should be used to improve the dimming accuracy. It is recommended for the V_{UVLO_EXTR} threshold voltage to be about 0.5V higher than the LED string voltage.

THERMAL SHUNT MECHANISM

IS32LT3140A is a linear constant current regulator subject thermal dissipation. The device begins current regulation when the voltage drop on the output source, called headroom voltage V_{HR} , exceeds the min headroom voltage V_{HR_MIN} . The power dissipation on the device will be proportional to the headroom voltage and LED current I_{LED} .

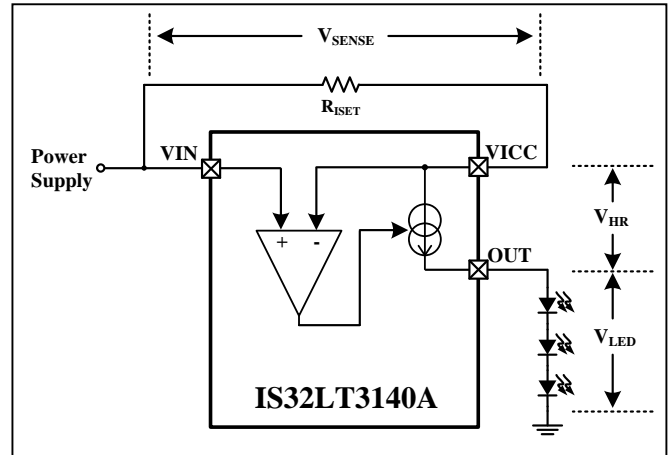

Figure 47 Voltage Drop

$$P_{3140A} = (V_{IN} - V_{SENSE} - V_{LED}) \times I_{OUT} = V_{HR} \times I_{OUT} \quad (6)$$

Note that the VIN quiescent current consumption is negligible and ignored in this calculation.

With a given LED string voltage (V_{LED}) and output current (I_{LED}), the higher the input voltage the larger the power dissipation on the IS32LT3140A. In automotive applications, the nominal battery voltage range is about 9V to 16V. However, electrical and radio-frequency disturbance frequently occurs in the vehicle environment that results in the supply voltage jumping over 16V. In a load dump condition the supply voltage could rise well above 40V. So the thermal management on device should be carefully considered when the output current is high, such as $I_{LED} \geq 200mA$.

To optimize the thermal resistance on the IS32LT3140A, an external power resistor (R_P) can be connected in parallel with the output current source to shunt some thermal energy away from the device..

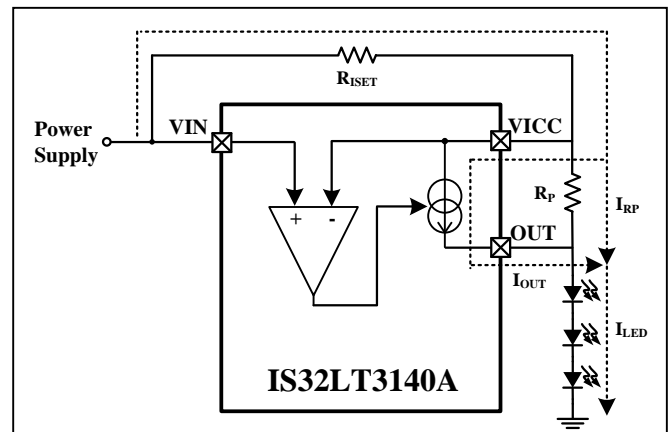

Figure 48 Thermal Shunt Resistor

When using an R_P power resistor, the internal regulation loop of IS32LT3140A still will drive the current source to regulate the voltage drop on the R_{SET} resistor to V_{SENSE} . As shown in Figure 49, the IS32LT3140A has different operating areas when using a power resistor. When the V_{IN} is low, the headroom voltage V_{HR} is insufficient for constant LED current

IS32LT3140A

regulation. If the V_{IN} rises above $(V_{LED}+V_{HR_MIN})$, the transition voltage V_{IN_OUTOFF} splits the operation into two areas: Constant Current area and Current Increasing area.

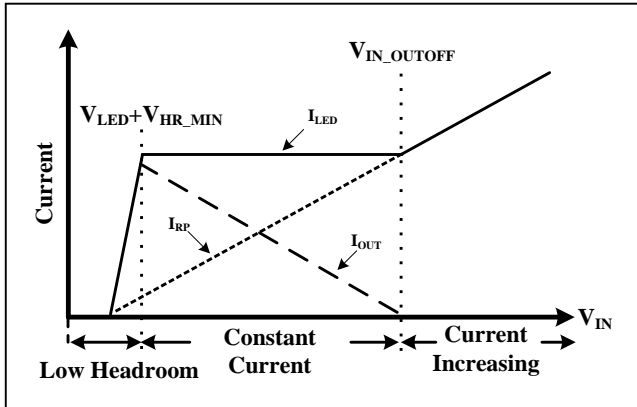

Figure 49 Current Distribution vs. Power Supply Voltage

Constant Current Area:

With a given R_{SET} value and a proper R_P shunt resistor, the LED current I_{LED} in this area is regulated by IS32LT3140A to be constant and can be calculated by the following Equation:

$$I_{LED} = I_{RP} + I_{OUT} = \frac{V_{SENSE}}{R_{SET}} \quad (7)$$

Where, I_{RP} is the current through the R_P shunt resistor and I_{OUT} is the output current of the current source.

The I_{OUT} linearly decreases following V_{IN} rising while the I_{RP} linearly increases due to the increase in V_{HR} . The I_{RP} is proportional to the headroom voltage V_{HR} and can be calculated by the following Equation:

$$I_{RP} = \frac{V_{HR}}{R_P} = \frac{V_{IN} - V_{SENSE} - V_{LED}}{R_P} \quad (8)$$

The power consumption on the R_P shunt resistor is:

$$P_{RP} = I_{RP}^2 \times R_P = \frac{(V_{IN} - V_{SENSE} - V_{LED})^2}{R_P} \quad (9)$$

The output current of the current source is:

$$I_{OUT} = I_{LED} - I_{RP} = I_{LED} - \frac{(V_{IN} - V_{SENSE} - V_{LED})}{R_P} \quad (10)$$

The power consumption on IS32LT3140A is:

$$P_{3140A} = I_{OUT} \times V_{HR} = (I_{LED} - I_{RP}) \times (V_{IN} - V_{SENSE} - V_{LED}) \quad (11)$$

Note that the V_{IN} quiescent current consumption is negligible and ignored in this calculation.

The power consumption distribution of the IS32LT3140A and the R_P shunt resistor are shown in Figure 50.

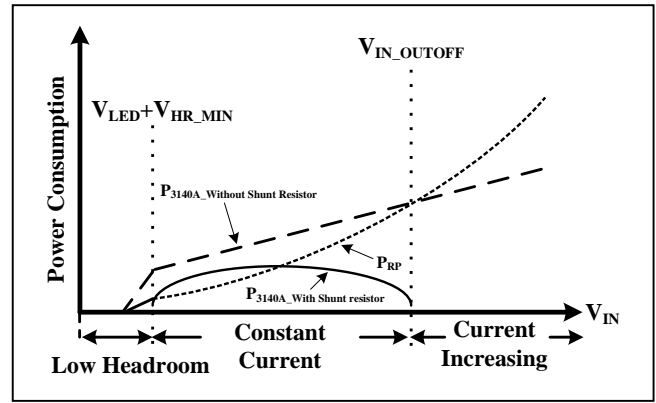

Figure 50 Power Distribution vs. Power Supply Voltage

The normal operating area is the Constant Current area, where the R_P power resistor shunts much of the thermal energy away from IS32LT3140A, especially at high V_{IN} . The thermal shunt mechanism significantly optimizes the device's thermal performance.

It is recommended to select a properly sized wattage resistor for R_P . A single high wattage resistor or several small wattage resistors in parallel can be used to sustain the power consumption at high V_{IN} voltage supply levels.

Constant Increasing Area:

If the V_{IN} is high enough to meet $I_{RP}=I_{LED}$, the I_{OUT} will be regulated to zero mA, which means all LED current flows through the R_P resistor and the current source is completely off.

$$V_{IN_OUTOFF} = I_{LED} \times R_P + V_{SENSE} + V_{LED} \quad (12)$$

Where, V_{IN_OUTOFF} is the V_{IN} resulting in $I_{OUT}=0A$. The power consumption on IS32LT3140A will also decrease to zero.

If the V_{IN} continues to rise over V_{IN_OUTOFF} , the current source of IS32LT3140A will remain in the off state and the LED current will no longer be constant but will linearly increase following the V_{IN} increase, which will be decided by:

$$I_{LED_INC} = \frac{V_{IN} - V_{LED}}{R_{SET} + R_P} \quad (13)$$

Where $V_{IN} > V_{IN_OUTOFF}$ and I_{LED_INC} is the LED current in Current Increasing area.

To achieve a constant current over the power supply voltage range, choose an R_P shunt resistor value so that V_{IN_OUTOFF} is never less than the maximum power supply voltage. So the R_P shunt resistor value should be calculated using the maximum power supply voltage V_{IN_MAX} :

$$R_P = \frac{V_{IN_MAX} - V_{LED} - V_{SENSE}}{I_{LED}} \quad (14)$$

IS32LT3140A

The V_{IN_MAX} means the maximum voltage which is possible to apply on the VIN pin. For a 12V automotive system, the V_{IN} voltage can range between 9V to 16V. However, a higher V_{IN} value can be used for passing extreme condition tests, such as a one minute burn-in test at 24V or 28V power supply. In this case, the V_{IN_MAX} should be 24V or 28V. The load dump test is another extreme condition, which could raise the supply voltage up to 40V. If calculating the R_P value according to the load dump voltage, the R_P value will be too large which will significantly degrade the thermal shunt effect in the normal operation voltage range of 9V to 16V. So a lower voltage rating TVS diode should be considered to be used upstream to clamp the maximum voltage appearing on the VIN pin.

Note the current through the R_P shunt resistor is always present and CANNOT be shut off by the IS32LT3140A. Therefore, the R_P shunt resistor should not be implemented if EN shutdown mode, PWM dimming and “one fail all fail” mode fault protection are to be used since they require turning off the output current. Only dimming method when using R_P shunt resistor is power supply modulation (PSM).

FAULT PROTECTION AND REPORTING

For robust system reliability, the IS32LT3140A integrates the detection circuitry to protect various fault conditions and report the fault conditions on the FAULTB pin which can be monitored by an external host. The fault protections include LED string open/short, single LED short, output over-current (not reported) and thermal shutdown. The FAULTB pin is an open drain structure with an internal 50k Ω (Typ.) resistor pulled up to an internal 4.5V (Typ.) LDO so it is allowed to float. The FAULTB pin will go low when the device enables fault detection and detects a fault condition. Refer to Table 1 and 2.

The FMODE is fault protection mode set pin. If the FMODE pin is set high (connected to VIN via a 10k Ω resistor), the fault protection is in ‘one fail other on’ mode, see Table 2; the FAULTB pin supports output function only. If the FMODE pin is set low (connected to GND), the fault protection is in ‘one fail all fail’ mode, see Table 1; the FAULTB pin supports both input and output functions. Externally pulling FAULTB pin low will disable the output. For lighting systems with multiple IS32LT3140A drivers which require the complete lighting system be shut down when a fault is detected, the FAULTB pin can be used in a parallel connection. A fault output by one device will pull low the FAULTB pins of the other parallel connected devices and simultaneously turn them off. This satisfies the “one fail all fail” operating requirement.

LED STRING OPEN PROTECTION

The LED string open detection is enabled if the UV pin voltage is above its rising voltage threshold, V_{UV_IH} , and disabled if below its falling voltage threshold, V_{UV_IL} . A proper resistor divider (R_{UV1} and R_{UV2}) connected from

VIN pin to UV pin can set a UVLO function for LED string open protection, which is to prevent insufficient V_{IN} falsely triggering LED string open and single LED short detections. The UVLO voltage threshold is programmed by the resistor divider.

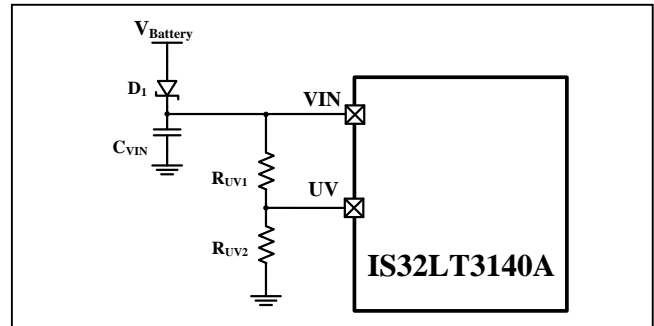

Figure 51 UVLO for LED String Open/Single LED Short Detection

$$V_{UVLO_FLTF} = V_{UV_IL} \times \frac{R_{UV1} + R_{UV2}}{R_{UV2}} \quad (15)$$

$$V_{UVLO_FLTR} = V_{UV_IH} \times \frac{R_{UV1} + R_{UV2}}{R_{UV2}} \quad (16)$$

It is recommend to set V_{UVLO_FLTF} at least 0.5V higher than the LED string voltage. Choose R_{UV1} and R_{UV2} to be 1% accuracy resistors with good temperature characteristic to ensure a stable and precise detection. On the PCB layout, this resistor divider must be placed as close to UV pin as possible to avoid noise interference. If the UV pin is unused, connect it to VIN pin via a 10k Ω resistor.

If the LED string is open, the OUT pin will be pulled up close to V_{ICC} pin voltage by the current source. If $V_{IN} > V_{UVLO_FLTR}$ and the V_{ICC} pin to OUT pin voltage drop, ($V_{VICC} - V_{OUT}$), falls below the open LED detect voltage threshold, V_{OD_R} , and persists for longer than the deglitch time t_{FD_DT} , the LED string open protection will be triggered and FAULTB pin will go low to report the fault condition. The output source will reserve a small current I_{RTR} for recovery detection, ignoring the PWM input.

The device will recover to normal operation and FAULTB pin will go back to high once the open condition is removed, ($V_{VICC} - V_{OUT}$) rising above the open LED detect voltage threshold, V_{OD_F} .

LED STRING SHORT PROTECTION

The LED string short condition is detected if the OUT pin voltage is lower than the short detect voltage threshold, V_{SCD_F} . Once short condition occurs and persists for longer than the deglitch time t_{FD_DT} , the LED string short protection will be triggered the FAULTB pin will go low to report the fault condition. The output source will reserve a small current I_{RTR} for recovery detection, ignoring the PWM input.

The device will recover to normal operation and FAULTB pin will go back to high once the short

IS32LT3140A

condition is removed, OUT pin voltage rising above the short detect voltage threshold, V_{SCD_R} .

SINGLE LED SHORT PROTECTION

The IS32LT3140A supports signal LED short detection by the SDH and SDL pins. The detection is enabled/disabled by UV pin as well to prevent insufficient V_{IN} falsely triggering. Please refer to Figure 51 and Equations 15 and 16.

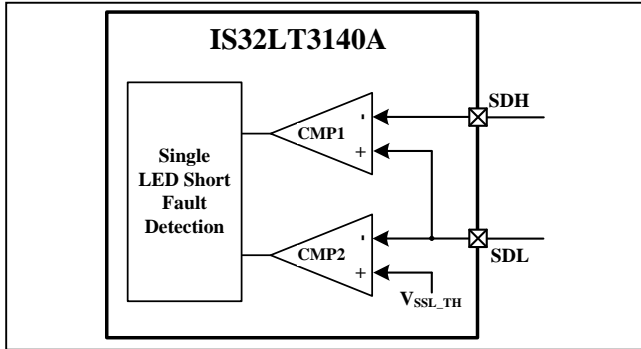

Figure 52 Single LED Short Detection

IS32LT3140A integrates two precise comparators to monitor and implement single LED short detection. The comparator CMP1 monitors the voltage difference between SDL pin and SDH pin, ($V_{SDH} - V_{SDL}$), and the comparator CMP2 monitors the voltage from the SDL pin to GND, V_{SDL} . In case of $V_{IN} > V_{UVLO_FLTR}$ and either ($V_{SDH} - V_{SDL}$) is greater than the internal high-side voltage threshold V_{SSH_TH} , or V_{SDL} drops below the internal low-side voltage threshold V_{SSL_TH} and persists for longer than the deglitch time t_{FD_SS} , the single LED short protection will be triggered and the FAULTB pin will go low to report the fault condition.

In the application, the SDL pin is connected to the anode of the bottom LED and the SDH is connected to OUT pin via a proper resistor divider; Figure 53 (A). The device uses the input voltage of the SDL pin, the forward voltage of the bottom LED, as the reference voltage of the CMP1 to monitor the SDH pin voltage. In case of any upper LED is shorted, the SDH pin voltage V_{SDH} will drop down. If it drops below V_{SDL} but greater than V_{SSH_TH} and persists for longer than the deglitch time t_{FD_SS} , the single LED short protection will be triggered and the FAULTB pin will go low to report the fault condition. The resistor divider ratio can be calculated by:

$$R_{SD1} = (N - 1) \times R_{SD2} \quad (17)$$

Where N is the number of LEDs in series. It is recommend that R_{SD1} and R_{SD2} be 1% accuracy resistors with good temperature characteristic and total resistance is greater than 100k Ω to ensure stable and precise detection. On the PCB layout, this resistor divider MUST be placed as close to SDH pin as possible to avoid noise interference.

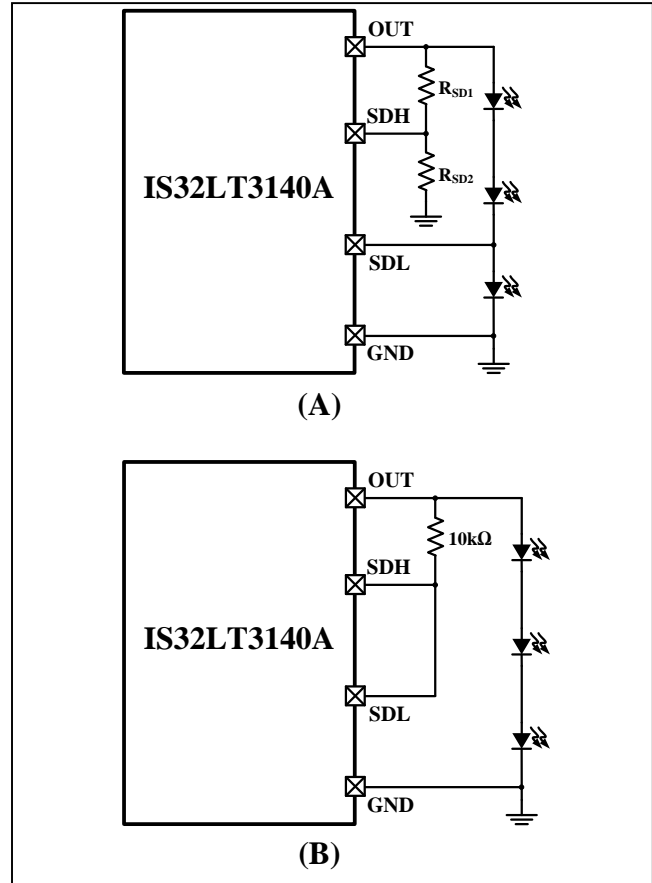

Figure 53 SDH and SDL Connection

Both V_{SDH} and V_{SDL} are equal to a single LED forward voltage in normal operation. However, the LED forward voltage always has deviation from part to part, even within same batch LEDs. If the deviation is greater than V_{SSH_TH} , the single LED short protection may be falsely triggered in normal operation. To prevent that, choose R_{SD1} value to be a slightly smaller than the result of Equation (17) and verify:

$$V_{f_MAX} - \frac{(V_{f_MIN} \times (N - 1) + V_{f_MAX}) \times R_{SD2}}{R_{SD1} + R_{SD2}} < V_{SSH_TH_MIN} \quad (18)$$

$$V_{f_MIN} - \frac{(V_{f_MAX} \times (N - 2) + V_{f_MIN}) \times R_{SD2}}{R_{SD1} + R_{SD2}} > V_{SSH_TH_MAX} \quad (19)$$

Where V_{f_MAX} and V_{f_MIN} are the maximum and minimum LED forward voltage. $V_{SSH_TH_MAX}$ and $V_{SSH_TH_MIN}$ are the maximum and minimum V_{SSH_TH} . Note that all LEDs in the string must be of same type, mixed type of LEDs will defeat the functionality of single LED short detection.

In the case of the bottom LED shorted, the SDL pin voltage V_{SDL} will drop below V_{SSL_TH} and persist for longer than the deglitch time t_{FD_SS} , the single LED short protection will be triggered and the FAULTB pin will go low to report the fault condition. The SMODE pin is for configuring the output state during the single LED short fault condition.

In "one fail all fail" mode (FMODE pin low):

IS32LT3140A

If the SMODE pin is set low (connected to GND), the output source will reserve a small current I_{RTR} for recovery detection, ignoring the PWM input. The remaining LED will be slightly visible. The device will recover to normal operation and FAULTB pin will go back to high once the single LED short condition is removed. In the event of the slight light is not allowed, set the SMODE pin high (connected to VIN via a 10kΩ resistor), then the single LED short protection will latch the output source at off state until power cycle or toggling EN to reset.

In “one fail other on” mode (FMODE pin high):

In most applications, the SMODE pin should be set high (connected to VIN via a 10kΩ resistor) to meet “one fail other on”. The remaining LEDs will keep normal current. The FAULTB pin will go back to high once the single

LED short condition is removed.

When the single LED short protection is unused, SDH and SDL pins must be connected together to OUT pin via a 10kΩ resistor. As Figure 53 (B).

THERMAL SHUTDOWN

In the event that the junction temperature exceeds T_{SD} (Typ. 175°C), the output source will go to the “OFF” state and FAULTB pin will pull low to report the fault condition. At this point, the IC presumably begins to cool off. Any attempt to toggle the channel back to the source condition before the IC cooled to below ($T_{SD}-T_{HY}$) (Typ. 150°C) will be blocked and the IC will not be allowed to restart. The FAULTB pin will recover to high once the IC has cooled down.

Table 1 Fault Actions Description of “One Fail All Fail”

V _{FMODE} = LOW (ONE FAIL ALL FAIL)							
UV Pin	Fault Type	Fault Condition	Output State		FAULTB Pin (with input function)	Recovery	
<V _{UV_IL}	LED string open or OUT short to VIN	Disabled					
	LED string short or OUT short to GND	$V_{OUT} < V_{SCD_F}$	Ignores the PWM input, outputs I_{RTR} for recovery detection		Pull low (If the FAULB pins of multiple devices are connected together, all devices will be off)	$V_{OUT} > V_{SCD_R}$	
	Single LED short	Disabled					
	Over temperature	$T_J > T_{SD}$	Off		Pull low (If the FAULB pins of multiple devices are connected together, all devices will be off)	$T_J < (T_{SD} - T_{HY})$	
>V _{UV_IH}	LED string open or OUT short to VIN	$(V_{VICC} - V_{OUT}) < V_{OD_R}$	Ignores the PWM input, outputs I_{RTR} for recovery detection			Pull low (If the FAULB pins of multiple devices are connected together, all devices will be off)	$(V_{VICC} - V_{OUT}) > V_{OD_F}$
	LED string short or OUT short to GND	$V_{OUT} < V_{SCD_F}$	Ignores the PWM input, outputs I_{RTR} for recovery detection				$V_{OUT} > V_{SCD_R}$
	Single LED short	$(V_{SDL} - V_{SDH}) > V_{SSH_TH}$ or $V_{SDL} < V_{SSL_TH}$	$V_{SMODE} = \text{low}$	Ignores the PWM input, outputs I_{RTR} for recovery detection			$(V_{SDL} - V_{SDH}) < V_{SSH_TH}$ or $V_{SDL} > (V_{SSL_TH} + V_{SSL_HY})$
			$V_{SMODE} = \text{high}$	Latched off			Power cycle or toggle EN pin
Over temperature	$T_J > T_{SD}$	Off			$T_J < (T_{SD} - T_{HY})$		

IS32LT3140A

Table 2 Fault Actions Description of ‘One Fail Other On’

V _{FMODE} = HIGH (ONE FAIL OTHER ON)							
UV Pin	Fault Type	Fault Condition	Output State		FAULTB Pin (without input function)	Recovery	
<V _{UV_IL}	LED string open or OUT short to VIN		Disabled				
	LED string short or OUT short to GND	V _{OUT} <V _{SCD_F}	Ignores the PWM input, outputs I _{RTR} for recovery detection		Pull low (If the FAULB pins of multiple devices are connected together, other devices will be on)	V _{OUT} >V _{SCD_R}	
	Single LED short		Disabled				
	Over temperature	T _J >T _{SD}	Off			T _J <(T _{SD} -T _{HY})	
>V _{UV_IH}	LED string open or OUT short to VIN	(V _{VICC} -V _{OUT})<V _{OD_R}	Ignores the PWM input, outputs I _{RTR} for recovery detection		Pull low (If the FAULB pins of multiple devices are connected together, other devices will be on)	(V _{VICC} -V _{OUT})>V _{OD_F}	
	LED string short or OUT short to GND	V _{OUT} <V _{SCD_F}	Ignores the PWM input, outputs I _{RTR} for recovery detection			V _{OUT} >V _{SCD_R}	
	Single LED short	(V _{SDL} -V _{SDH})>V _{SSH_TH} or V _{SDL} <V _{SSL_TH}	V _{SMODE} = low	Ignores the PWM input, outputs I _{RTR} for recovery detection		(V _{SDL} -V _{SDH})<V _{SSH_TH} or V _{SDL} >(V _{SSL_TH} +V _{SSL_L_HY})	
			V _{SMODE} = high	Keeps normal output			
	Over temperature	T _J >T _{SD}	Off				T _J <(T _{SD} -T _{HY})

THERMAL CONSIDERATIONS

The package thermal resistance, θ_{JA} , determines the amount of heat that can pass from the silicon die to the surrounding ambient environment. The θ_{JA} is a measure of the temperature rise created by power dissipation and is usually measured in degree Celsius per watt (°C/W). The junction temperature, T_J , can be calculated by the rise of the silicon temperature, ΔT , the power dissipation on IS32LT3140A, P_{3140A} , and the package thermal resistance, θ_{JA} , as in Equation (20):

$$T_J = T_A + \Delta T = T_A + P_{3140A} \times \theta_{JA} \quad (20)$$

The P_{3140A} is described in the “Thermal Shunt Mechanism” section.

When operating the chip at high ambient temperatures, or when the supply voltage is high, care must be taken to avoid exceeding the package power dissipation limits. The maximum power dissipation at $T_A=25^\circ\text{C}$ can be calculated using the following Equation (21):

$$P_{D(MAX)} = \frac{150^\circ\text{C} - 25^\circ\text{C}}{\theta_{JA}} \quad (21)$$

So,

$$P_{D(MAX)} = \frac{150^\circ\text{C} - 25^\circ\text{C}}{45.5^\circ\text{C/W}} \approx 2.75\text{W} \quad (22)$$

for eTSSOP-14 package.

Figure 54, shows the power derating of the IS32LT3140A on a JEDEC board (in accordance with JESD 51-5 and JESD 51-7) standing in still air.

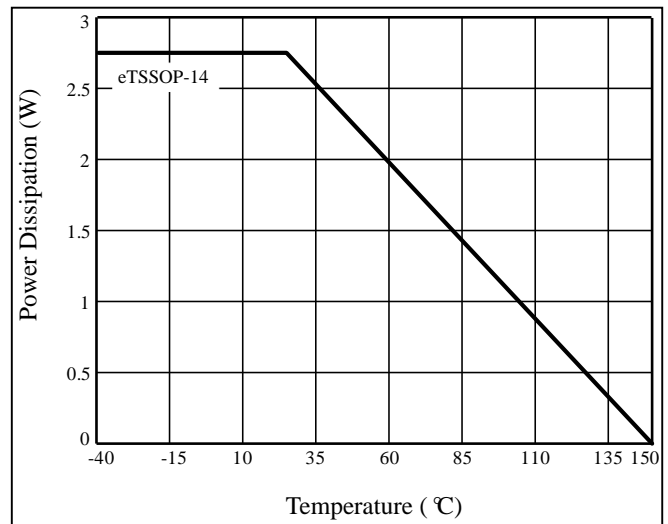

Figure 54 Dissipation Curve (eTSSOP-14)

In the thermal shunt application, the R_P will share quite a lot power dissipation; therefore its package power rating should be sufficient to prevent heat run away.

When designing the Printed Circuit Board (PCB) layout, double-sided PCB with a large copper area on each side of the board directly under the IS32LT3140A and the thermal shunt resistor. Multiple thermal vias, as shown in Figure 55, will help to conduct heat from the exposed pad of the IS32LT3140A and the thermal shunt resistor to the copper on each side of the board. To avoid the heat buildup, the thermal shunt resistor should be spread out on the PCB board with some distance from IS32LT3140A.

IS32LT3140A

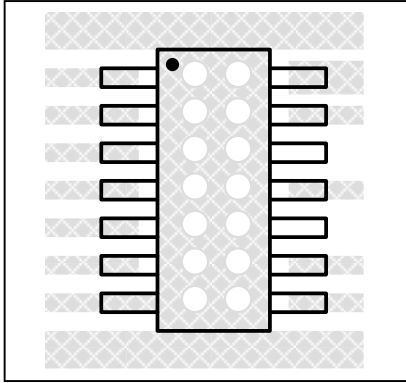

Figure 55 Board Via Layout For Thermal Dissipation

IS32LT3140A

CLASSIFICATION REFLOW PROFILES

Profile Feature	Pb-Free Assembly
Preheat & Soak Temperature min (T _{smin}) Temperature max (T _{smax}) Time (T _{smin} to T _{smax}) (t _s)	150°C 200°C 60-120 seconds
Average ramp-up rate (T _{smax} to T _p)	3°C/second max.
Liquidous temperature (T _L) Time at liquidous (t _L)	217°C 60-150 seconds
Peak package body temperature (T _p)*	Max 260°C
Time (t _p)** within 5°C of the specified classification temperature (T _c)	Max 30 seconds
Average ramp-down rate (T _p to T _{smax})	6°C/second max.
Time 25°C to peak temperature	8 minutes max.

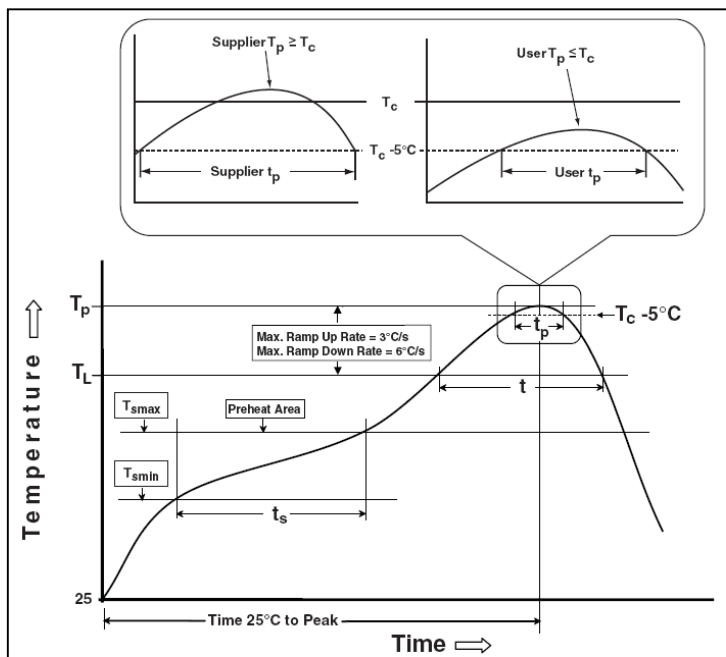
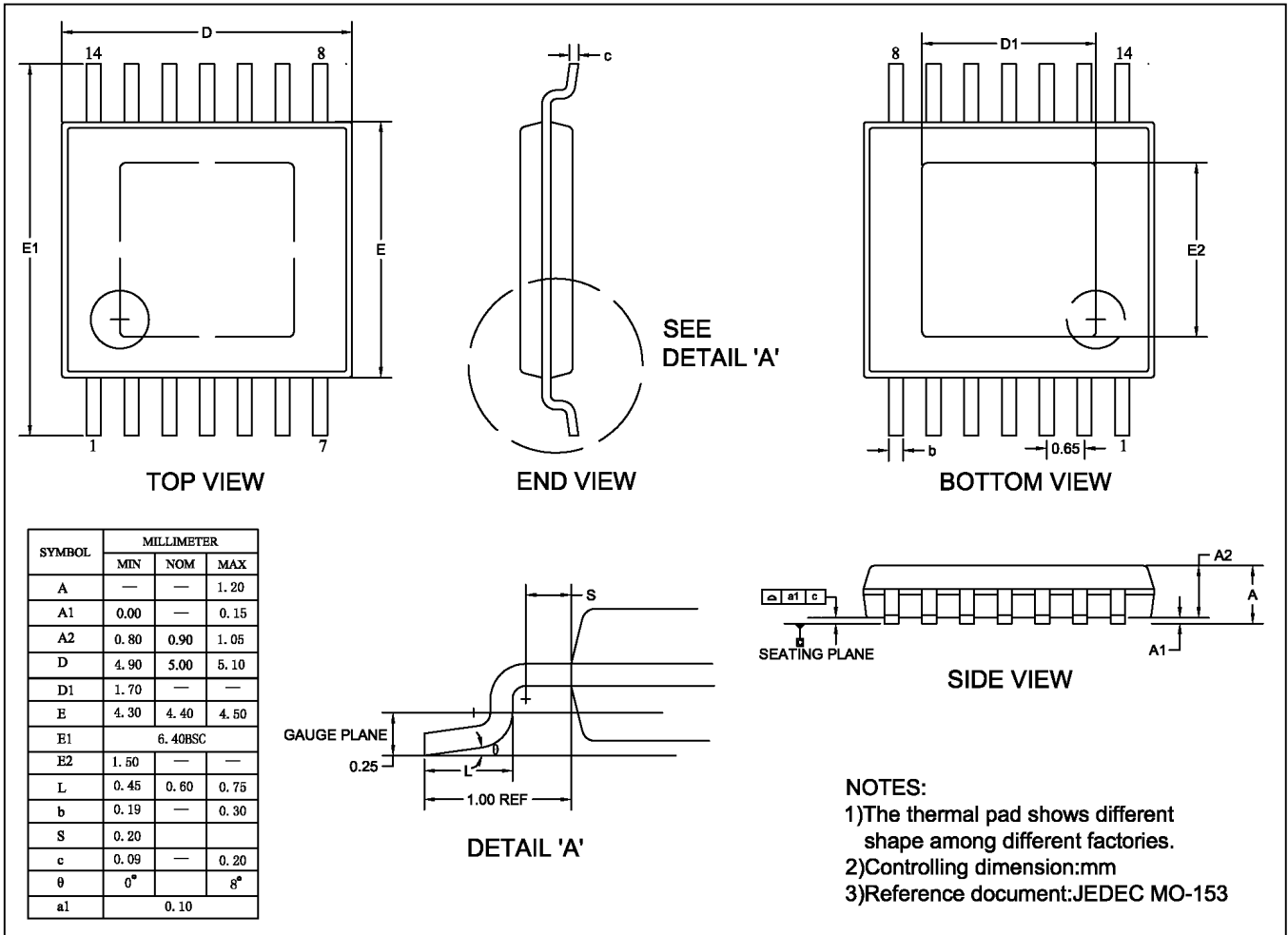

Figure 56 Classification Profile

IS32LT3140A

PACKAGE INFORMATION

eTSSOP-14



IS32LT3140A

RECOMMENDED LAND PATTERN

eTSSOP-14

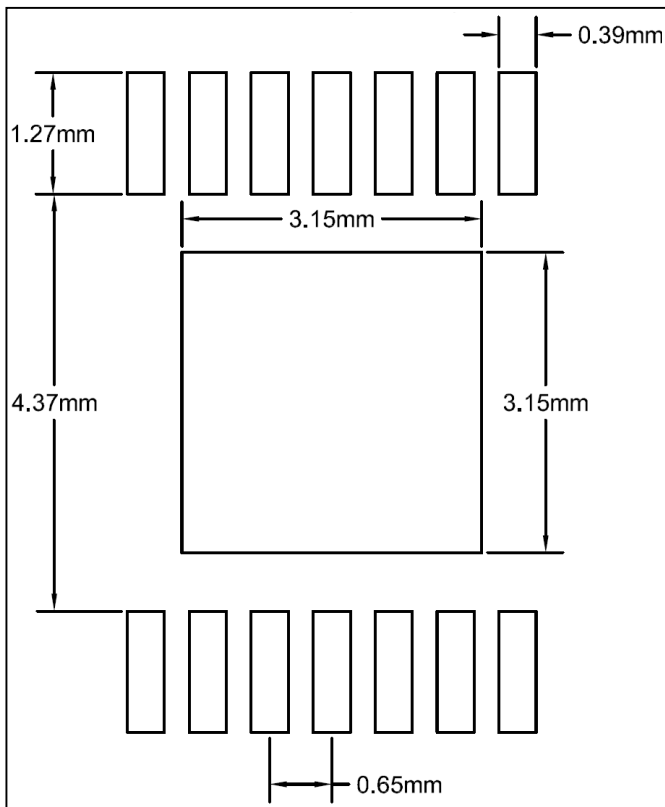

Note:

1. Land pattern complies to IPC-7351.
2. All dimensions in MM.
3. This document (including dimensions, notes & specs) is a recommendation based on typical circuit board manufacturing parameters. Since land pattern design depends on many factors unknown (eg. user's board manufacturing specs), user must determine suitability for use.

IS32LT3140A



A Division of 

REVISION HISTORY

Revision	Detail Information	Date
0A	Initial release	2020.11.02
A	Update EC table and release to final version	2021.02.08

X-ON Electronics

Largest Supplier of Electrical and Electronic Components

Click to view similar products for [LED Lighting Drivers](#) category:

Click to view products by [ISSI](#) manufacturer:

Other Similar products are found below :

[LV5235V-MPB-H](#) [MB39C602PNF-G-JNEFE1](#) [MIC2871YMK-T5](#) [AL1676-10BS7-13](#) [AL1676-20AS7-13](#) [AP5726WUG-7](#) [MX877RTR](#)
[ICL8201](#) [IS31BL3228B-UTLS2-TR](#) [IS31BL3506B-TTLS2-TR](#) [AL3157F-7](#) [AP5725FDCG-7](#) [AP5726FDCG-7](#) [LV52204MTTBG](#)
[AP5725WUG-7](#) [STP4CMPQTR](#) [NCL30086BDR2G](#) [CAT4004BHU2-GT3](#) [LV52207AXA-VH](#) [AP1694AS-13](#) [TLE4242EJ](#) [AS3688](#)
[IS31LT3172-GRLS4-TR](#) [TLD2311EL](#) [KTD2694EDQ-TR](#) [KTZ8864EJAA-TR](#) [IS32LT3174-GRLA3-TR](#) [ZXLD1374QESTTC](#) [MP2488DN-](#)
[LF-Z](#) [NLM0010XTSA1](#) [AL1676-20BS7-13](#) [MPQ7220GF-AEC1-P](#) [MPQ7220GF-AEC1-Z](#) [MPQ4425BGJ-AEC1-Z](#) [IS31FL3737B-QFLS4-](#)
[TR](#) [IS31FL3239-QFLS4-TR](#) [KTD2058EUAC-TR](#) [KTD2037EWE-TR](#) [DIO5662ST6](#) [IS31BL3508A-TTLS2-TR](#) [MAX20052CATC/V+](#)
[MAX25606AUP/V+](#) [BD6586MUV-E2](#) [BD9206EFV-E2](#) [BD9416FS-E2](#) [LYT4227E](#) [LYT6079C-TL](#) [MP3394SGF-P](#) [MP4689AGN-P](#)
[MPQ4425AGQB-AEC1-Z](#)