

IS32LT3175N/P SINGLE CHANNEL LINEAR LED DRIVER WITH FADE IN/FADE OUT AND PWM DIMMING

DESCRIPTION

The IS32LT3175 is a single channel linear programmable current regulator capable of up to 150mA. It integrates a debounce and latch circuit on the channel enable pin (EN) to facilitate the use of a low cost momentary contact switch. The PWM pin can be interfaced to a logic level “courtesy light” signal to directly drive the LED channel. The IS32LT3175P accepts a positive polarity PWM signal while the IS32LT3175N accepts a negative polarity PWM signal.

The device operates as a stand-alone LED driver configurable with external resistors; no microcontroller is required. A single external resistor programs the current level, while two separate resistors independently program the fade in and fade out ramp rate for the channel.

The device integrates a 63 steps fade in and fade out algorithm (Gamma correction) which causes the output LED current to gradually ramp up to the full source value after the EN pin is pulsed. The same controller causes the LED current to gradually ramp down to zero if the EN pin is pulsed while the output channel is ON. The fade ramp can be interrupted mid-cycle before completion of the ramp cycle. The EN pin will accept either a momentary contact switch or logic level signal pulsed low.

The IS32LT3175 is targeted at the automotive market with end applications to include map and dome lighting as well as exterior accent lighting. For 12V automotive applications the low dropout driver can support 1 to 3 LEDs ($V_F = 3.2V$) per channel.

QUICK START

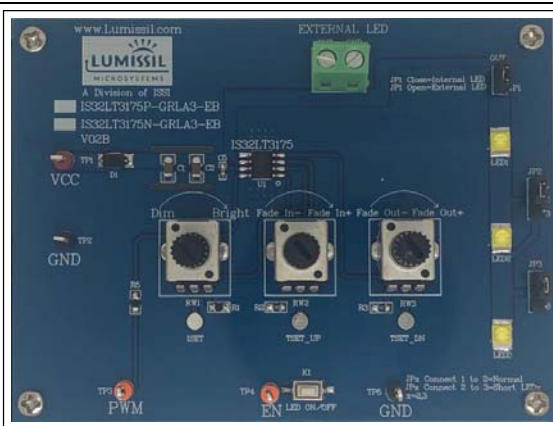

Figure 1: Photo of IS32LT3175N/P Evaluation Board

FEATURES

- Operating voltage 5V to 42V
- Single channel current source
 - Programmable current via a single external resistor
 - Configurable from 20mA to 150mA
- Momentary contact button EN input
 - Input is debounced and latched
 - Higher priority than PWM input
 - Gamma corrected Fade In/Out algorithm
 - Pull down resistors set independent fade IN and OUT ramp time
- PWM input pin driven by external PWM source
 - PWM directly drives the current source
 - IS32LT3175P – Positive polarity
 - IS32LT3175N – Negative polarity
- Fault Protection:
 - OUT pin shorted to GND
 - ISET pin shorted to GND
 - Over temperature
- SOP-8-EP package
- Automotive Grade - AEC-Q100
- Operating temperature range from $-40^{\circ}C \sim +125^{\circ}C$

RECOMMENDED EQUIPMENT

- 12V,1A DC power supply

ABSOLUTE MAXIMUM RATINGS

- $\leq 42V$ power supply

Caution: Do not exceed the conditions listed above, otherwise the board will be damaged.

PROCEDURE

The IS32LT3175N/P evaluation board is fully assembled and tested. Follow the steps listed below to verify board operation.

Caution: Do not turn on the power supply until all connections are completed.

- 1) Connect the ground terminal of the power supply to the GND and the positive terminal to the VCC.
Note: The V_{CC} supply should be set close to the IS32LT3175N/P minimal headroom voltage of 0.9V ($V_{CC} - V_{outx}$) for best thermal performance. The board can be operated with a larger headroom voltage as long as the increase in package temperature is monitored. Exceeding the device package temperature specification will cause the device to enter thermal protection mode.
- 2) The output current of is adjusted by the variable resistor (RW1). Turn RW1 counter clockwise to decrease the output current and clockwise to increase the output current. The test point ISET can be used to detect the resistor value at the ISET pin. The final resistance can be measured

IS32LT3175N/P SINGLE CHANNEL LINEAR LED DRIVER WITH FADE IN/FADE OUT AND PWM DIMMING



A Division of **ST**

- with an ohm meter across ISET and GND pins. Use this measured resistor value to replace the variable resistor RW1 and R1 (see schematic Figure 2).
- 3) The fade in time is adjusted by the variable resistor (RW2). Turn RW2 counter clockwise to decrease fade in time, and clockwise to increase fade in time. Once the desired fade in time is set, measure the resistor value across TSET_UP and GND. Use this measured resistor value to replace the variable resistor RW2 and R2 (see schematic Figure 2).
 - 4) The fade out time is adjusted by the variable resistor (RW3). Turn RW3 counter clockwise to decrease fade out time, and clockwise to increase fade out time. Once the desired fade out time is set, measure the resistor value across TSET_DN and GND. Use this measured resistor value to replace the variable resistor RW3 and R3 (see schematic Figure 2).
 - 5) Momentary contact buttons (K1) is used to enable/disable the Output LED. Press K1 to change the state of the onboard LED string anytime, even though the fade time doesn't complete.
 - 6) JP1 is used to connect the IS32LT3175N/P Output (pin6) to the onboard LED string (LED1~LED3). Use one of the green terminal blocks to connect an external LED string. Remove the corresponding jumper header (JP1) to disable the onboard LED string.
Note: Connecting an external LED string without removing the onboard string jumper header will drive both onboard and external LED strings in parallel resulting in lower current drive to the LED string.
 - 7) The on board LED string size can be adjusted from 1 to 3 LEDs by using jumper headers JP2~JP3. Connecting the header to pins 2-3 disables the corresponding LED, ie JP2 pins 2-3 disables LED2. To enable all the LED1~LED3 connect JP2~JP3 to pins 1-2.

ORDERING INFORMATION

| Part No. | Temperature Range | Package |
|----------------------|-----------------------------|---------------------|
| IS32LT3175P-GRLA3-EB | -40°C ~ +125°C (Automotive) | SOP-8-EP, Lead-free |
| IS32LT3175N-GRLA3-EB | | |

Table 1: Ordering Information

For pricing, delivery, and ordering information, please contact Lumissil's analog marketing team at analog@Lumissil.com or (408) 969-6600.

EVALUATION BOARD OPERATION

IS32LT3175N/P evaluation board drives one string of WLEDs. There are three variable resistors used for adjusting the LED current (RW1), fade in time (RW2), fade out time (RW3).

SETTING THE FADE TIME

The fade time is set by two external programming resistors; R_{TSET_UP} and R_{TSET_DN} . The R_{TSET_UP} connected to the TSET_UP pin configures the fade ramp ON time while the R_{TSET_DN} connected to the TSET_DN pin configures the fade ramp out time. The fade time (In or Out) is programmable by Equation (2):

$$t \approx R_{TSET} \times 2.5 \mu s \quad (2)$$

For example, $R_{TSET}=100k\Omega$, Fade In/Out time is about 0.25s.

Note: In order to get the optimized effect, the recommended fading time is between 1.5s ($R_{TSET}=600k\Omega$) and 0.25s ($R_{TSET}=100k\Omega$).

If either the TSET_UP or TSET_DN pin is tied directly to GND, the corresponding fade function is canceled and the ramp time is about 70 μ s, or 'instant on'. However, the debounce feature of the EN pin is not disabled.

OUTPUT CURRENT SETTING

A single programming resistor (R_{ISET}) controls the maximum output current for the output channel simultaneously. The programming resistor may be computed using the following Equation:

$$R_{ISET} = \frac{1500}{I_{SET}} \quad (10k\Omega \leq R_{ISET} \leq 75k\Omega)$$

The device is protected from an output over current condition caused by an accidental short circuit of the ISET pin, by internally limiting the maximum current in the event of an ISET short circuit to 205mA.

IS32LT3175N/P SINGLE CHANNEL LINEAR LED DRIVER WITH FADE IN/FADE OUT AND PWM DIMMING

FADE IN AND FADE OUT DIMMING

The LED fade function can be accomplished in one of two methods; 1) by applying a PWM control signal to the PWM pin, or 2) when the EN pin is pulled low.

PWM Dimming – The PWM pin can be driven by an external PWM signal source to accomplish LED dimming. The integrated gamma correction and fade IN/OUT ramp functions are disabled when actively driving the PWM pin. The PWM pin input is ignored if the LED channel was previously active due to the EN pin. The EN pin will override the PWM function; it can be used to toggle the LED channel from its previous state even though the PWM pin is active.

The recommended PWM signal frequency range is 50Hz-300Hz. The duty cycle can be 0-100%. The output current of the PWM dimming is given by:

$$I_{OUT} = \frac{1500}{R_{ISET}} \times D_{PWM}$$

Where, D_{PWM} is the duty cycle of the PWM.

EN Dimming –The LED output current will gradually ramp up from zero to the final value as programmed by the resistor (R_{ISET}) connected to the ISET pin. The time period over which the ramping happens is determined by the resistor (R_{TSET_UP}) connected to the TSET_UP pin for Fade In time and by resistor (R_{TSET_DN}) connected to TSET_DN pin for Fade Out time. The output current will ramp up (or down) in 63 steps, with integrated gamma correction for an extremely visual

linear lumen output of the LED. The ramp time can be interrupted mid-cycle each time the EN pin is pulled low.

The EN function has priority over the PWM function; if the LED has been turned on due to the EN function then the PWM dimming pin input is ignored.

FAULT DETECTION

An output shorted to GND fault is detected if the output voltage on a channel drops below the low voltage threshold V_{SCD} and remains below the threshold for t_{FD} . The channel (OUT) with the short condition will reduce its output current to 20% of I_{SET} . When short condition is removed, output current will recover to original value.

When output current is larger than limit value, about 260mA, the output current will be clamped. When the open fault condition is recovered, there will be a large current pulse about 10 μ s.

Debounce

Output control is provided by a debounced switch input, providing an ON/OFF toggle action for various switch or button characteristics. An internal debounce circuit will condition the EN input signal so a single press of the mechanical switch doesn't appear like multiple presses. The EN input is debounced by typically 37ms.

Note: The debounce time applies to both falling and rising edges of the EN signal.

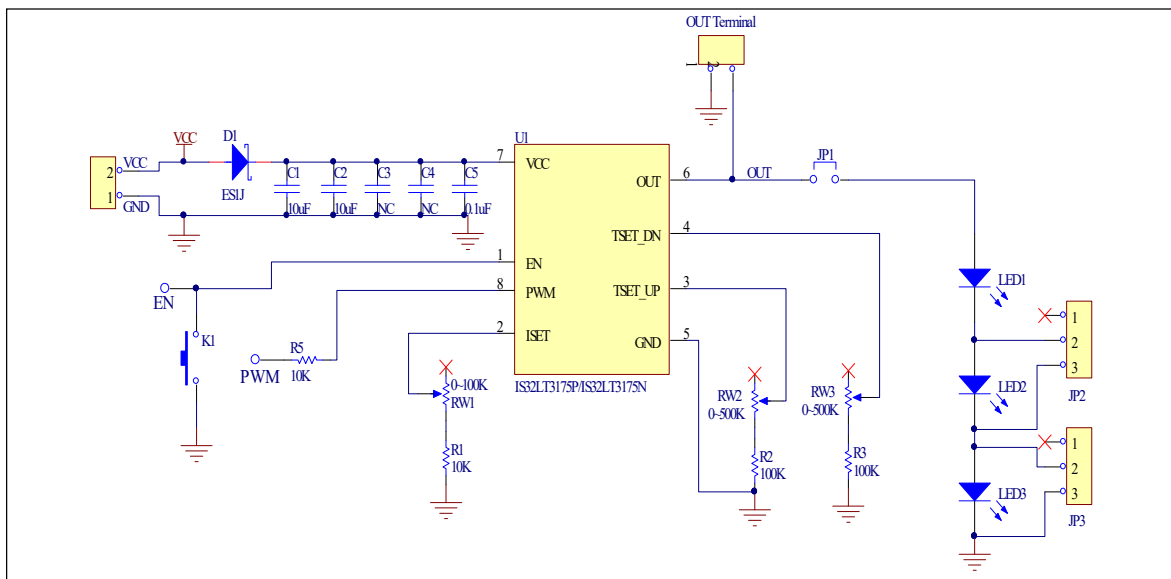

Figure 2: IS32LT3175N/P Application Schematic

IS32LT3175N/P SINGLE CHANNEL LINEAR LED DRIVER WITH FADE IN/FADE OUT AND PWM DIMMING



A Division of ISSI

BILL OF MATERIALS

| Name | Symbol | Description | Qty | Supplier | Part No. |
|-------------------|------------------------|-------------------------------|-----|-----------|-------------------|
| LED Driver | U1 | LED Driver | 1 | Lumissil | IS32LT3175N/P |
| Resistor | R2,R3 | RES,100k,1/8W,±1%,SMD | 2 | YAGEO | RC0805FR-07100KL |
| Resistor | R1,R5 | RES,10k,1/8W,±1%,SMD | 2 | YAGEO | RC0805FR-0710KL |
| Variable Resistor | RW1 | Trimmer, 100kohm ±10% 0.5W | 1 | Bourns | 3386P-1-104 |
| Variable Resistor | RW2,RW3 | Trimmer, 500kohm ±10% 0.5W | 2 | Bourns | 3386P-1-504 |
| Capacitor | C1,C2 | CAP,4.7µF,50V,±10%,SMD | 2 | YAGEO | CC1206KKX7R9BB475 |
| Capacitor | C5 | CAP,0.1µF,50V,±10%,SMD | 1 | YAGEO | CC0603KKX7R9BB104 |
| Capacitor | C3,C4 | Not installed | | | |
| Diode | D1 | 1A,600V, DO-214AC,SMA ES1J | 1 | Fairchild | ES1J |
| Button | K1 | Momentary Button SMD | 1 | | |
| Terminal blocks | OUT1 | green terminal blocks | 1 | | |
| Headers | JP2,JP3 | 3 pin headers | 2 | | |
| Headers | JP1 | 2 pin headers | 1 | | |
| Test point | VCC,GND, PWM,EN,GND | 1 pin test point | 5 | | |

Bill of materials, refer to Figure 2 above.

IS32LT3175N/P SINGLE CHANNEL LINEAR LED DRIVER WITH FADE IN/FADE OUT AND PWM DIMMING

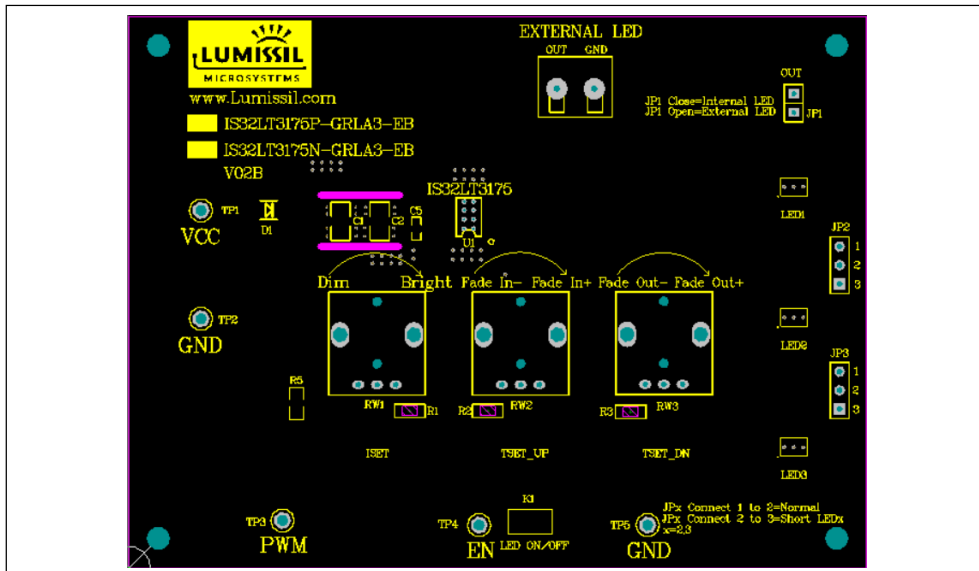

Figure 3: Board Component Placement Guide - Top Layer

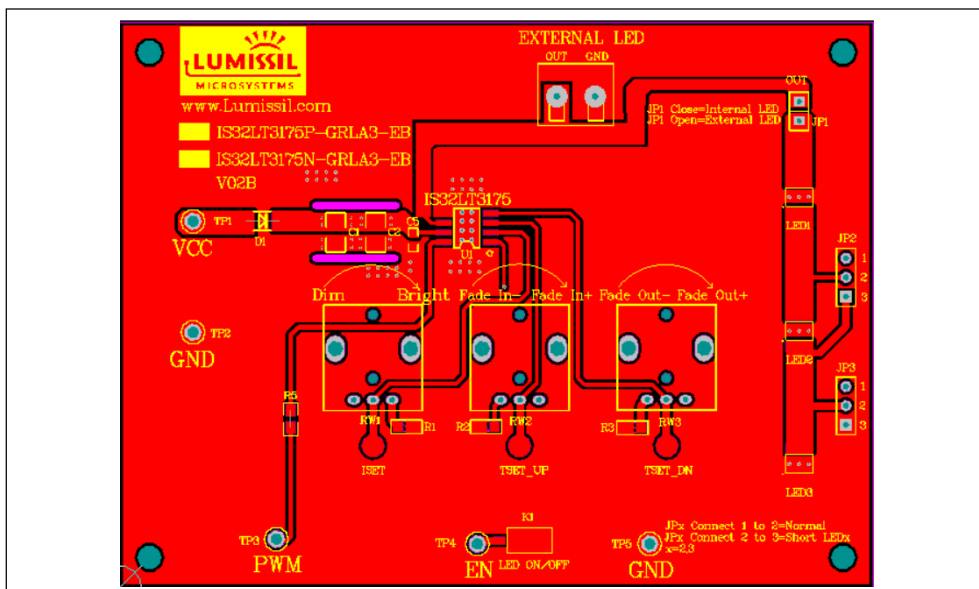

Figure 4: Board PCB Layout - Top Layer

IS32LT3175N/P SINGLE CHANNEL LINEAR LED DRIVER WITH FADE IN/FADE OUT AND PWM DIMMING



A Division of ISSI

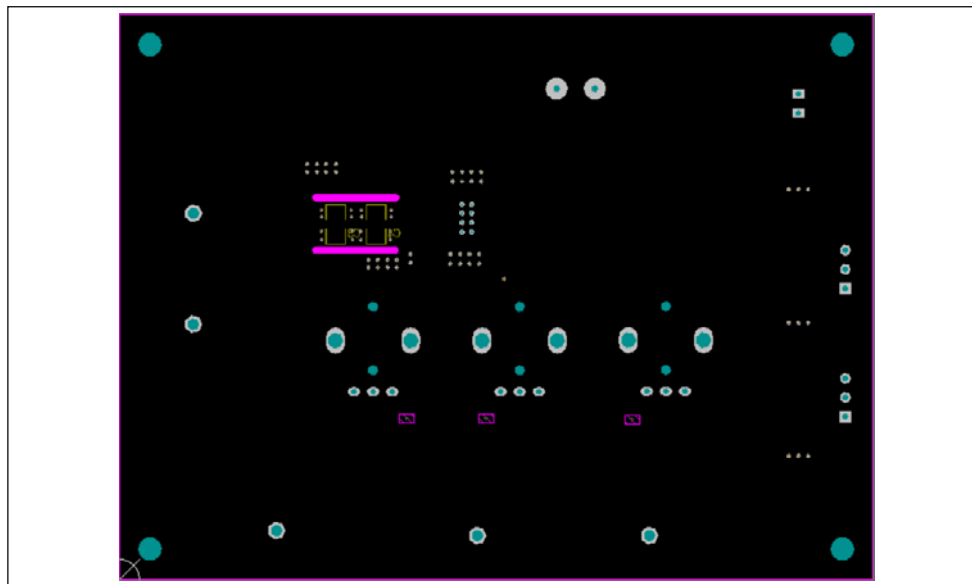

Figure 5: Board Component Placement Guide - Bottom Layer

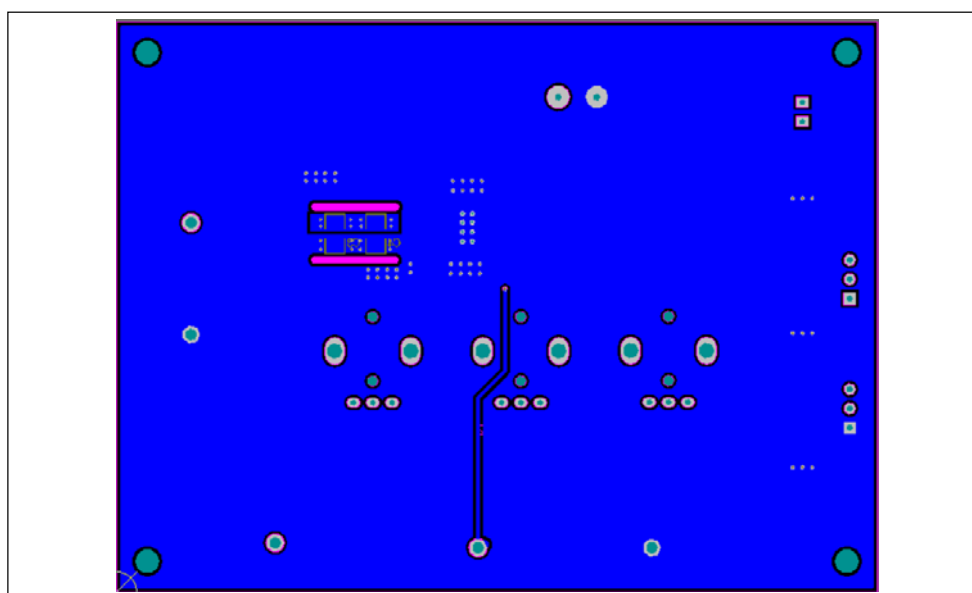

Figure 6: Board PCB Layout - Bottom Layer

Copyright © 2021 Lumissil Microsystems. All rights reserved. Lumissil Microsystems reserves the right to make changes to this specification and its products at any time without notice. Lumissil Microsystems assumes no liability arising out of the application or use of any information, products or services described herein. Customers are advised to obtain the latest version of this device specification before relying on any published information and before placing orders for products.

Lumissil Microsystems does not recommend the use of any of its products in life support applications where the failure or malfunction of the product can reasonably be expected to cause failure of the life support system or to significantly affect its safety or effectiveness. Products are not authorized for use in such applications unless Lumissil Microsystems receives written assurance to its satisfaction, that:

- a.) the risk of injury or damage has been minimized;
- b.) the user assume all such risks; and
- c.) potential liability of Lumissil Microsystems is adequately protected under the circumstances

IS32LT3175N/P SINGLE CHANNEL LINEAR LED DRIVER WITH FADE IN/FADE OUT AND PWM DIMMING



A Division of **ISSI**

REVISION HISTORY

| Revision | Detail Information | Date |
|----------|---|------------|
| B | Initial release | 2016.03.29 |
| C | Update PCB layout and Application Schematic | 2021.08.11 |

X-ON Electronics

Largest Supplier of Electrical and Electronic Components

Click to view similar products for [LED Lighting Development Tools](#) category:

Click to view products by [ISSI](#) manufacturer:

Other Similar products are found below :

[MIC2870YFT EV](#) [TDGL014](#) [ISL97682IRTZEVALZ](#) [EA6358NH](#) [TPS92315EVM-516](#) [STEVAL-LLL006V1](#) [IS31LT3948-GRLS4-EB](#)
[PIM526](#) [PIM527](#) [MAX6946EVKIT+](#) [MAX20070EVKIT#](#) [MAX20090BEVKIT#](#) [PIM498](#) [AP8800EV1](#) [ZXLD1370/1EV4](#) [1216.1013](#) [1270](#)
[1271.2004](#) [1272.1030](#) [1273.1010](#) [1278.1010](#) [1279.1002](#) [1279.1001](#) [1282.1000](#) [1293.1900](#) [1293.1800](#) [1293.1700](#) [1293.1500](#) [1293.1100](#)
[1282.1400](#) [1282.1100](#) [1293.1200](#) [1282.1200](#) [1293.1000](#) [1282.6000](#) [1296.2012](#) [MIKROE-2520](#) [1721](#) [1762](#) [PIR-GEVB](#) [TPS61161EVM-243](#)
[STEVAL-ILL056V1](#) [ADM00767](#) [STEVAL-ILL080V1](#) [DC1224A](#) [DC1160A](#) [DC1039A-A](#) [DC1816B](#) [DC1511A-A](#) [DC1274A](#)