

## 1M x 8 LOW VOLTAGE, ULTRA LOW POWER CMOS STATIC RAM

MARCH 2006

### FEATURES

- High-speed access time: 55ns, 70ns
- CMOS low power operation:
  - 36 mW (typical) operating
  - 12  $\mu$ W (typical) CMOS standby
- TTL compatible interface levels
- Single power supply:
  - 2.5V--3.6V  $V_{DD}$  (IS62WV10248BLL)
- Fully static operation: no clock or refresh required
- Three state outputs
- Industrial temperature available
- Lead-free available

### DESCRIPTION

The *ISSI* IS62WV10248BLL is a high-speed, 8M bit static RAMs organized as 1M words by 8 bits. It is fabricated using *ISSI's* high-performance CMOS technology. This highly reliable process coupled with innovative circuit design techniques, yields high-performance and low power consumption devices.

When  $\overline{CS1}$  is HIGH (deselected) or when CS2 is LOW (deselected), the device assumes a standby mode at which the power dissipation can be reduced down with CMOS input levels.

Easy memory expansion is provided by using Chip Enable and Output Enable inputs. The active LOW Write Enable ( $\overline{WE}$ ) controls both writing and reading of the memory.

The IS62WV10248BLL is packaged in the JEDEC standard 48-pin mini BGA (7.2mm x 8.7mm).

### FUNCTIONAL BLOCK DIAGRAM

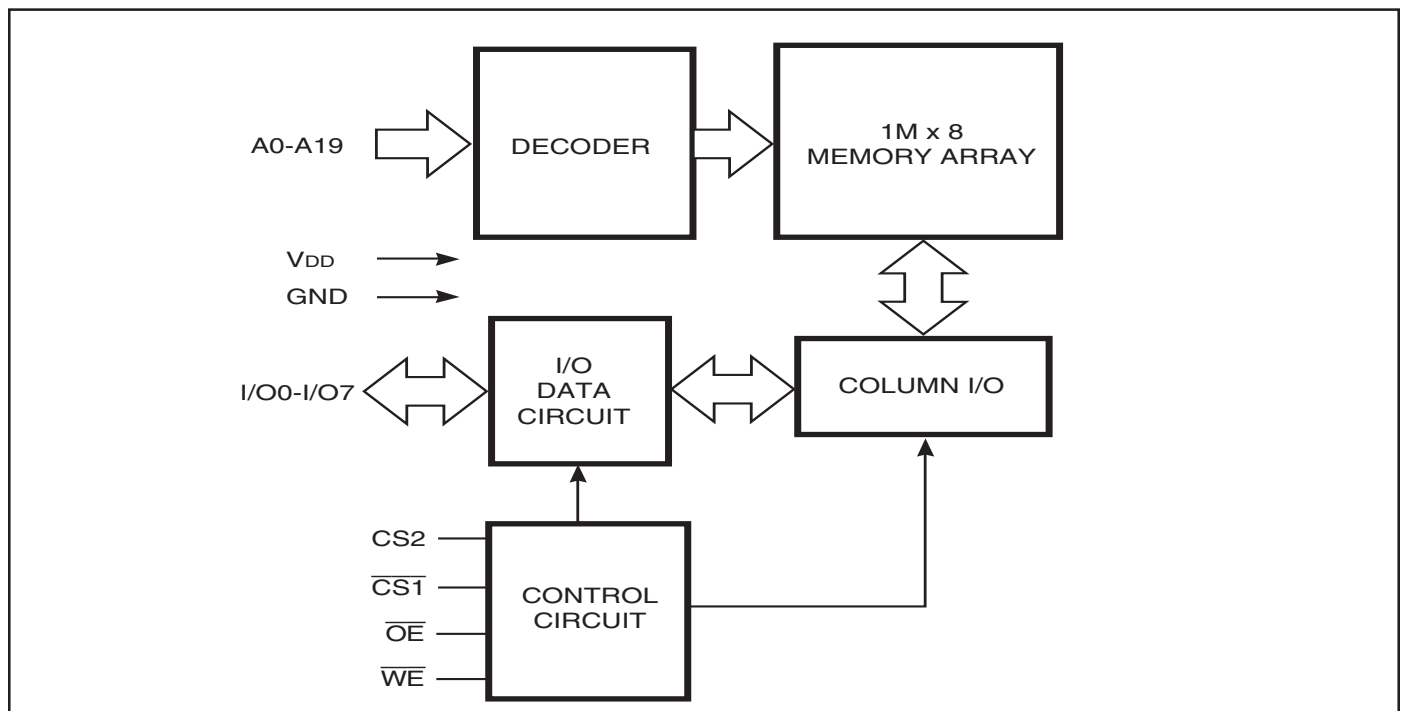

Copyright © 2006 Integrated Silicon Solution, Inc. All rights reserved. ISSI reserves the right to make changes to this specification and its products at any time without notice. ISSI assumes no liability arising out of the application or use of any information, products or services described herein. Customers are advised to obtain the latest version of this device specification before relying on any published information and before placing orders for products.

**PIN DESCRIPTIONS**

A0-A19	Address Inputs
$\overline{CS1}$	Chip Enable 1 Input
CS2	Chip Enable 2 Input
$\overline{OE}$	Output Enable Input
$\overline{WE}$	Write Enable Input
I/O0-I/O7	Input/Output
NC	No Connection
V <sub>DD</sub>	Power
GND	Ground

**PIN CONFIGURATION**

48-pin mini BGA (B) (7.2mm x 8.7mm)

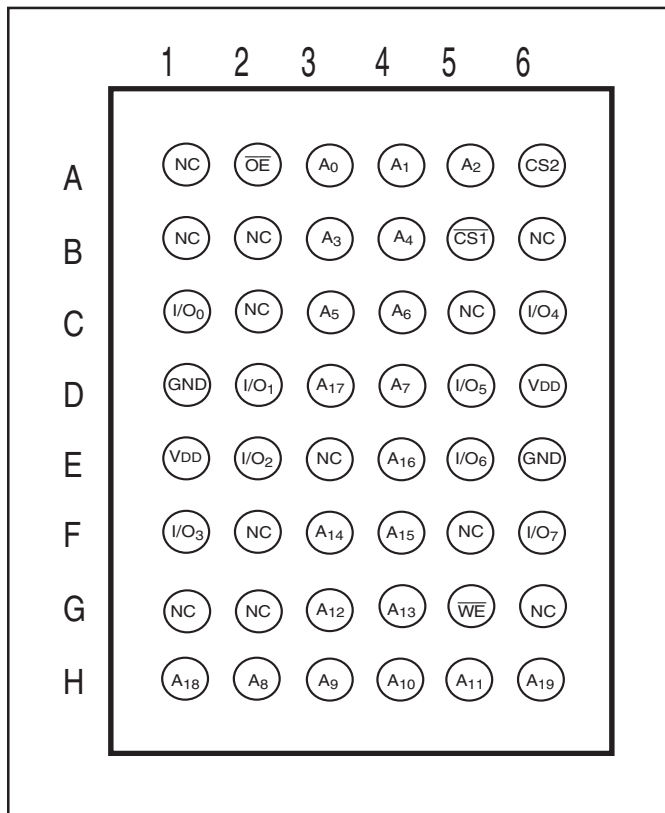

## TRUTH TABLE

Mode	$\overline{WE}$	$\overline{CS1}$	CS2	$\overline{OE}$	I/O Operation	V <sub>DD</sub> Current
Not Selected	X	H	X	X	High-Z	ISB1, ISB2
(Power-down)	X	X	L	X	High-Z	ISB1, ISB2
Output Disabled	H	L	H	H	High-Z	I <sub>CC</sub>
Read	H	L	H	L	D <sub>OUT</sub>	I <sub>CC</sub>
Write	L	L	H	X	D <sub>IN</sub>	I <sub>CC</sub>

ABSOLUTE MAXIMUM RATINGS<sup>(1)</sup>

Symbol	Parameter	Value	Unit
V <sub>TERM</sub>	Terminal Voltage with Respect to GND	-0.2 to V <sub>DD</sub> +0.3	V
V <sub>DD</sub>	V <sub>DD</sub> Related to GND	-0.2 to +3.8	V
T <sub>STG</sub>	Storage Temperature	-65 to +150	°C
P <sub>T</sub>	Power Dissipation	1.0	W

## Note:

1. Stress greater than those listed under ABSOLUTE MAXIMUM RATINGS may cause permanent damage to the device. This is a stress rating only and functional operation of the device at these or any other conditions above those indicated in the operational sections of this specification is not implied. Exposure to absolute maximum rating conditions for extended periods may affect reliability.

OPERATING RANGE (V<sub>DD</sub>)

Range	Ambient Temperature	IS62WV10248BLL
Commercial	0°C to +70°C	2.5V - 3.6V
Industrial	-40°C to +85°C	2.5V - 3.6V

## DC ELECTRICAL CHARACTERISTICS (Over Operating Range)

Symbol	Parameter	Test Conditions	V <sub>DD</sub>	Min.	Max.	Unit
V <sub>OH</sub>	Output HIGH Voltage	I <sub>OH</sub> = -1 mA	2.5-3.6V	2.2	—	V
V <sub>OL</sub>	Output LOW Voltage	I <sub>OL</sub> = 2.1 mA	2.5-3.6V	—	0.4	V
V <sub>IH</sub>	Input HIGH Voltage		2.5-3.6V	2.2	V <sub>DD</sub> + 0.3	V
V <sub>IL</sub> <sup>(1)</sup>	Input LOW Voltage		2.5-3.6V	-0.2	0.6	V
I <sub>LI</sub>	Input Leakage	GND ≤ V <sub>IN</sub> ≤ V <sub>DD</sub>		-1	1	μA
I <sub>LO</sub>	Output Leakage	GND ≤ V <sub>OUT</sub> ≤ V <sub>DD</sub> , Outputs Disabled		-1	1	μA

## Notes:

1. V<sub>IL</sub> (min.) = -1.0V for pulse width less than 10 ns.

CAPACITANCE<sup>(1)</sup>

Symbol	Parameter	Conditions	Max.	Unit
C <sub>IN</sub>	Input Capacitance	V <sub>IN</sub> = 0V	8	pF
C <sub>OUT</sub>	Input/Output Capacitance	V <sub>OUT</sub> = 0V	10	pF

**Note:**

1. Tested initially and after any design or process changes that may affect these parameters.

## AC TEST CONDITIONS

Parameter	IS62WV10248BLL (Unit)
Input Pulse Level	0.4 to V <sub>DD</sub> -0.3V
Input Rise and Fall Times	5 ns
Input and Output Timing and Reference Level	V <sub>REF</sub>
Output Load	See Figures 1 and 2

IS62WV10248BLL 2.5V - 3.6V	
R1(Ω)	1029
R2(Ω)	1728
V <sub>REF</sub>	1.5V
V <sub>TM</sub>	2.8V

## AC TEST LOADS

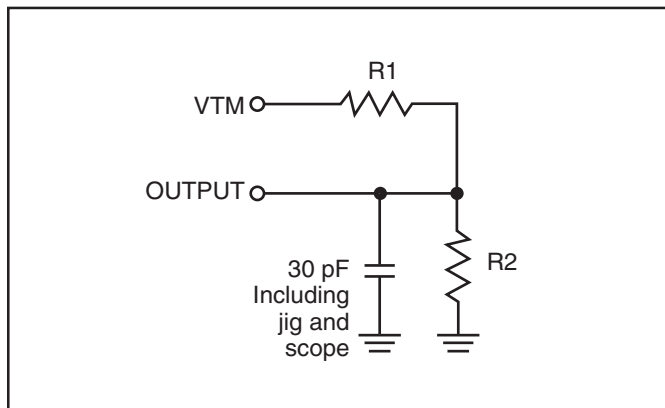

Figure 1

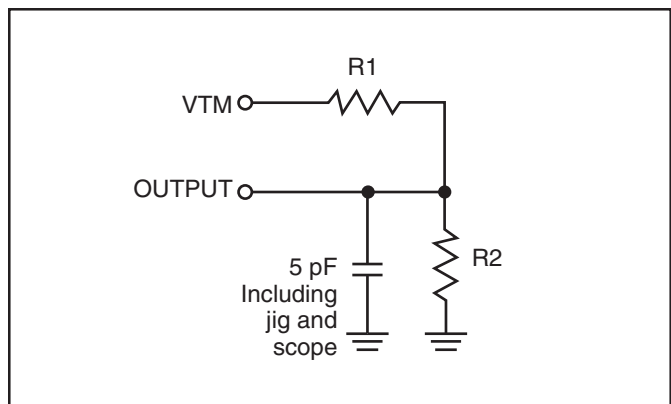

Figure 2

POWER SUPPLY CHARACTERISTICS<sup>(1)</sup> (Over Operating Range)

## IS62WV10248BLL

Symbol	Parameter	Test Conditions		Max.	Max.	Unit
				55	70	
I <sub>OC</sub>	V <sub>DD</sub> Dynamic Operating Supply Current	V <sub>DD</sub> = Max., I <sub>OUT</sub> = 0 mA, f = f <sub>MAX</sub>	Com.	30	25	mA
			Ind.	35	30	
I <sub>CC1</sub>	Operating Supply Current	V <sub>DD</sub> = Max., $\overline{CS1} = 0.2V$ $\overline{WE} = V_{DD} - 0.2V$ CS2 = V <sub>DD</sub> - 0.2V, f = 1MHz	Com.	5	5	mA
			Ind.	5	5	
I <sub>SB1</sub>	TTL Standby Current (TTL Inputs)	V <sub>DD</sub> = Max., V <sub>IN</sub> = V <sub>IH</sub> or V <sub>IL</sub> $\overline{CS1} = V_{IH}$ , CS2 = V <sub>IL</sub> , f = 1 MHz	Com.	0.3	0.3	mA
			Ind.	0.3	0.3	
I <sub>SB2</sub>	CMOS Standby Current (CMOS Inputs)	V <sub>DD</sub> = Max., $\overline{CS1} \geq V_{DD} - 0.2V$ , CS2 ≤ 0.2V, V <sub>IN</sub> ≥ V <sub>DD</sub> - 0.2V, or V <sub>IN</sub> ≤ 0.2V, f = 0	Com.	20	20	μA
			Ind. typ. <sup>(1)</sup>	25	25	
				3	3	

**Note:**

1. Typical Values are measured at V<sub>DD</sub> = 3.0V, T<sub>A</sub> = 25°C and not 100% tested.

READ CYCLE SWITCHING CHARACTERISTICS<sup>(1)</sup> (Over Operating Range)

Symbol	Parameter	55 ns		70 ns		Unit
		Min.	Max.	Min.	Max.	
$t_{RC}$	Read Cycle Time	55	—	70	—	ns
$t_{AA}$	Address Access Time	—	55	—	70	ns
$t_{OHA}$	Output Hold Time	10	—	10	—	ns
$t_{ACS1}/t_{ACS2}$	$\overline{CS1}/CS2$ Access Time	—	55	—	70	ns
$t_{DOE}$	$\overline{OE}$ Access Time	—	25	—	35	ns
$t_{HZOE}^{(2)}$	$\overline{OE}$ to High-Z Output	—	20	—	25	ns
$t_{LZOE}^{(2)}$	$\overline{OE}$ to Low-Z Output	5	—	5	—	ns
$t_{HZCS1}/t_{HZCS2}^{(2)}$	$\overline{CS1}/CS2$ to High-Z Output	0	20	0	25	ns
$t_{LZCS1}/t_{LZCS2}^{(2)}$	$\overline{CS1}/CS2$ to Low-Z Output	10	—	10	—	ns

**Notes:**

1. Test conditions assume signal transition times of 5 ns or less, timing reference levels of 1.5V, input pulse levels of 0.4V to  $V_{DD}-0.3V$  and output loading specified in Figure 1.
2. Tested with the load in Figure 2. Transition is measured  $\pm 500$  mV from steady-state voltage. Not 100% tested.

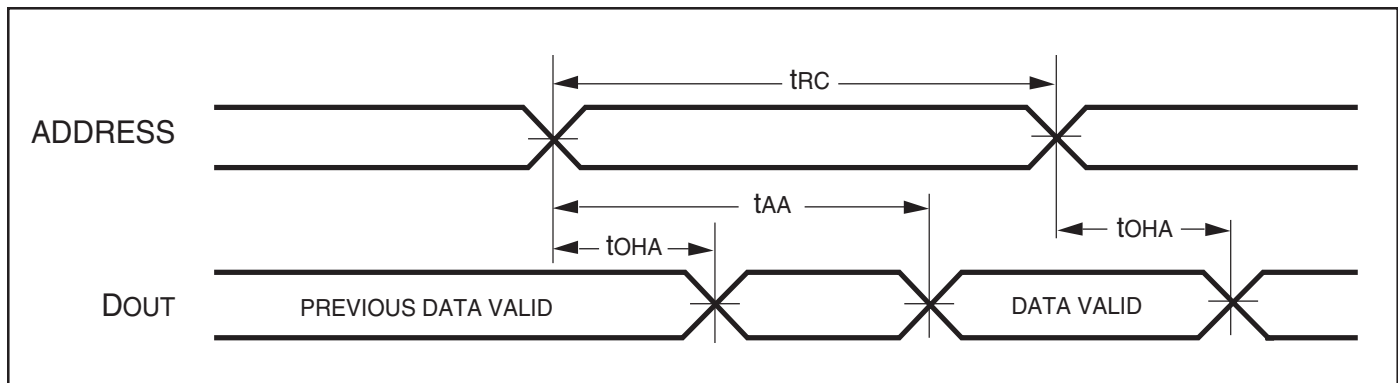
**AC WAVEFORMS****READ CYCLE NO. 1<sup>(1,2)</sup>** (Address Controlled) ( $\overline{CS1} = \overline{OE} = V_{IL}$ ,  $CS2 = \overline{WE} = V_{IH}$ )



WRITE CYCLE SWITCHING CHARACTERISTICS<sup>(1,2)</sup> (Over Operating Range)

Symbol	Parameter	55 ns		70 ns		Unit
		Min.	Max.	Min.	Max.	
$t_{WC}$	Write Cycle Time	55	—	70	—	ns
$t_{SCS1}/t_{SCS2}$	$\overline{CS1}/CS2$ to Write End	45	—	60	—	ns
$t_{AW}$	Address Setup Time to Write End	45	—	60	—	ns
$t_{HA}$	Address Hold from Write End	0	—	0	—	ns
$t_{SA}$	Address Setup Time	0	—	0	—	ns
$t_{PWE}^{(4)}$	$\overline{WE}$ Pulse Width	40	—	50	—	ns
$t_{SD}$	Data Setup to Write End	25	—	30	—	ns
$t_{HD}$	Data Hold from Write End	0	—	0	—	ns
$t_{HZWE}^{(3)}$	$\overline{WE}$ LOW to High-Z Output	—	25	—	25	ns
$t_{LZWE}^{(3)}$	$\overline{WE}$ HIGH to Low-Z Output	5	—	5	—	ns

## Notes:

1. Test conditions assume signal transition times of 5 ns or less, timing reference levels of 1.5V, input pulse levels of 0.4V to  $V_{DD}-0.3V$  and output loading specified in Figure 1.
2. The internal write time is defined by the overlap of  $\overline{CS1}$  LOW, CS2 HIGH and  $\overline{WE}$  LOW. All signals must be in valid states to initiate a Write, but any one can go inactive to terminate the Write. The Data Input Setup and Hold timing are referenced to the rising or falling edge of the signal that terminates the write.
3. Tested with the load in Figure 2. Transition is measured  $\pm 500$  mV from steady-state voltage. Not 100% tested.
4.  $t_{PWE} > t_{HZWE} + t_{SD}$  when  $\overline{OE}$  is LOW.

## AC WAVEFORMS

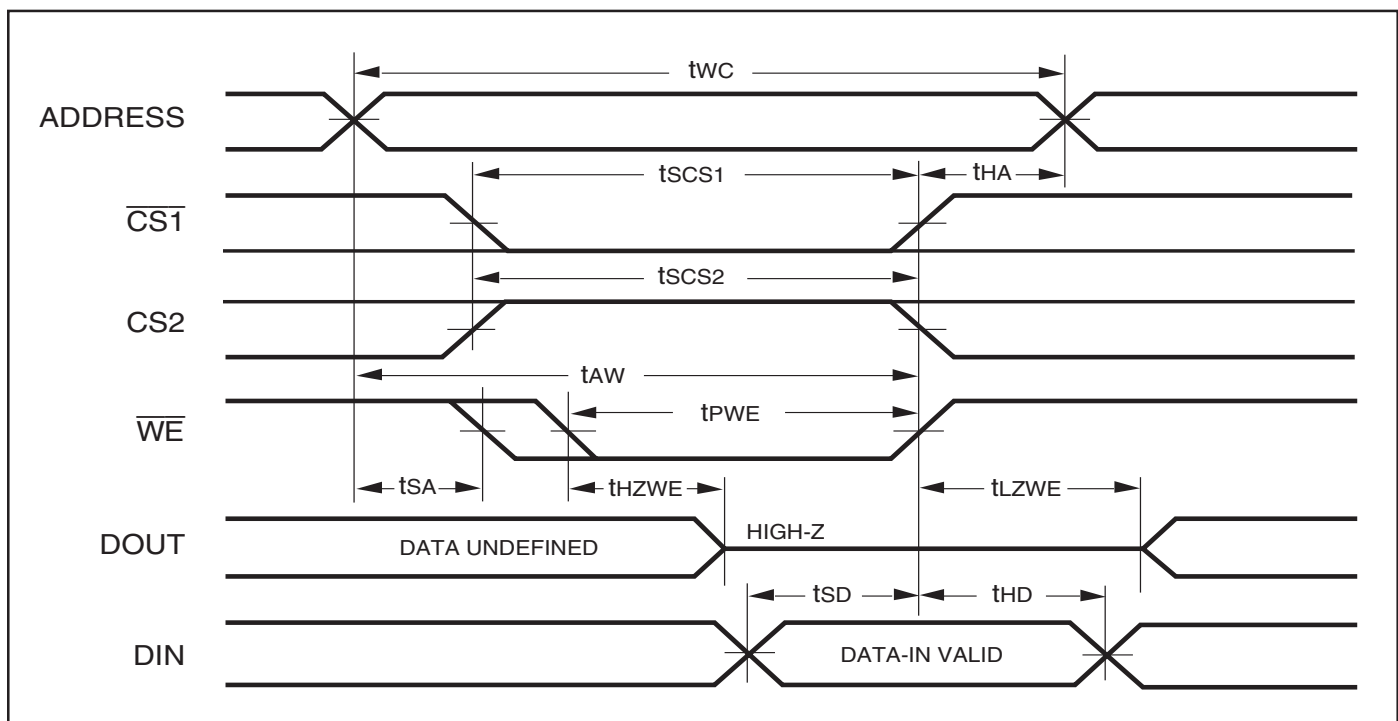
WRITE CYCLE NO. 1 ( $\overline{CS1}/CS2$  Controlled,  $\overline{OE} = \text{HIGH or LOW}$ )



**WRITE CYCLE NO. 2** ( $\overline{WE}$  Controlled:  $\overline{OE}$  is HIGH During Write Cycle)

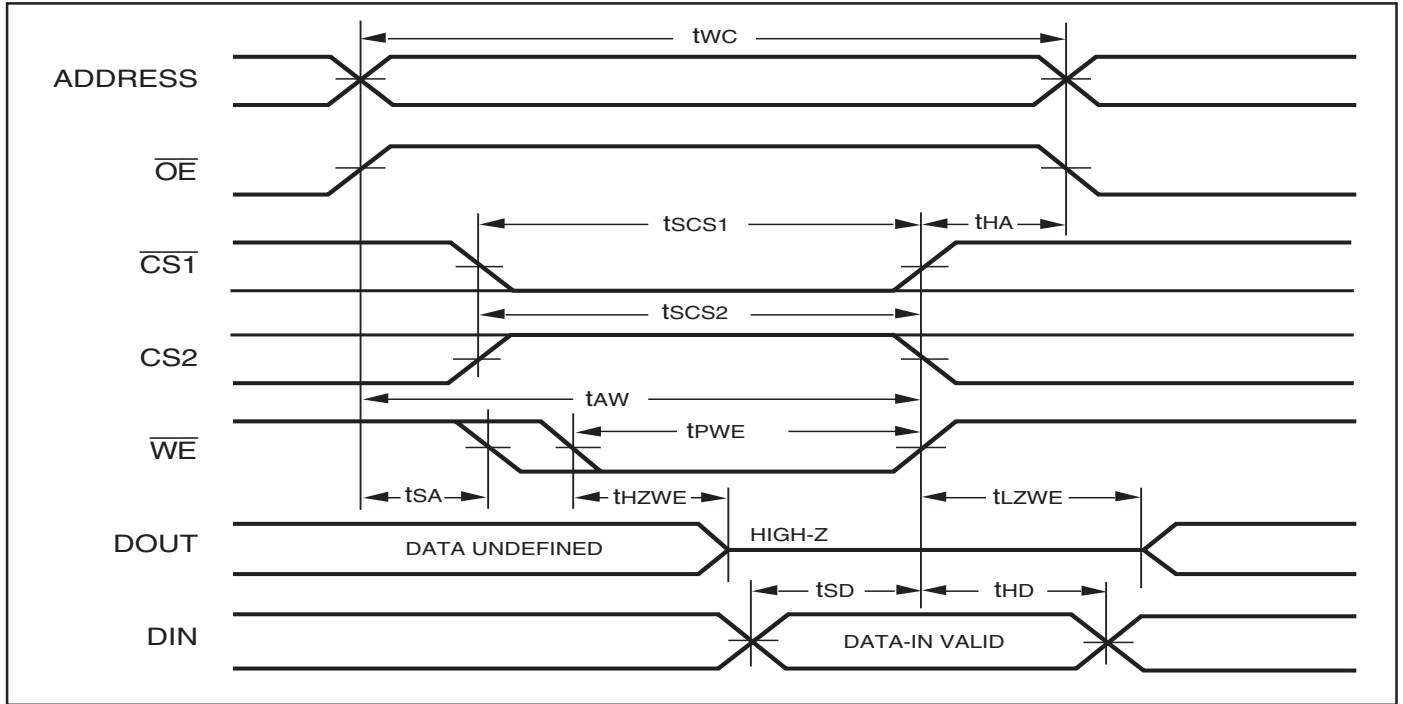

**WRITE CYCLE NO. 3** ( $\overline{WE}$  Controlled:  $\overline{OE}$  is LOW During Write Cycle)

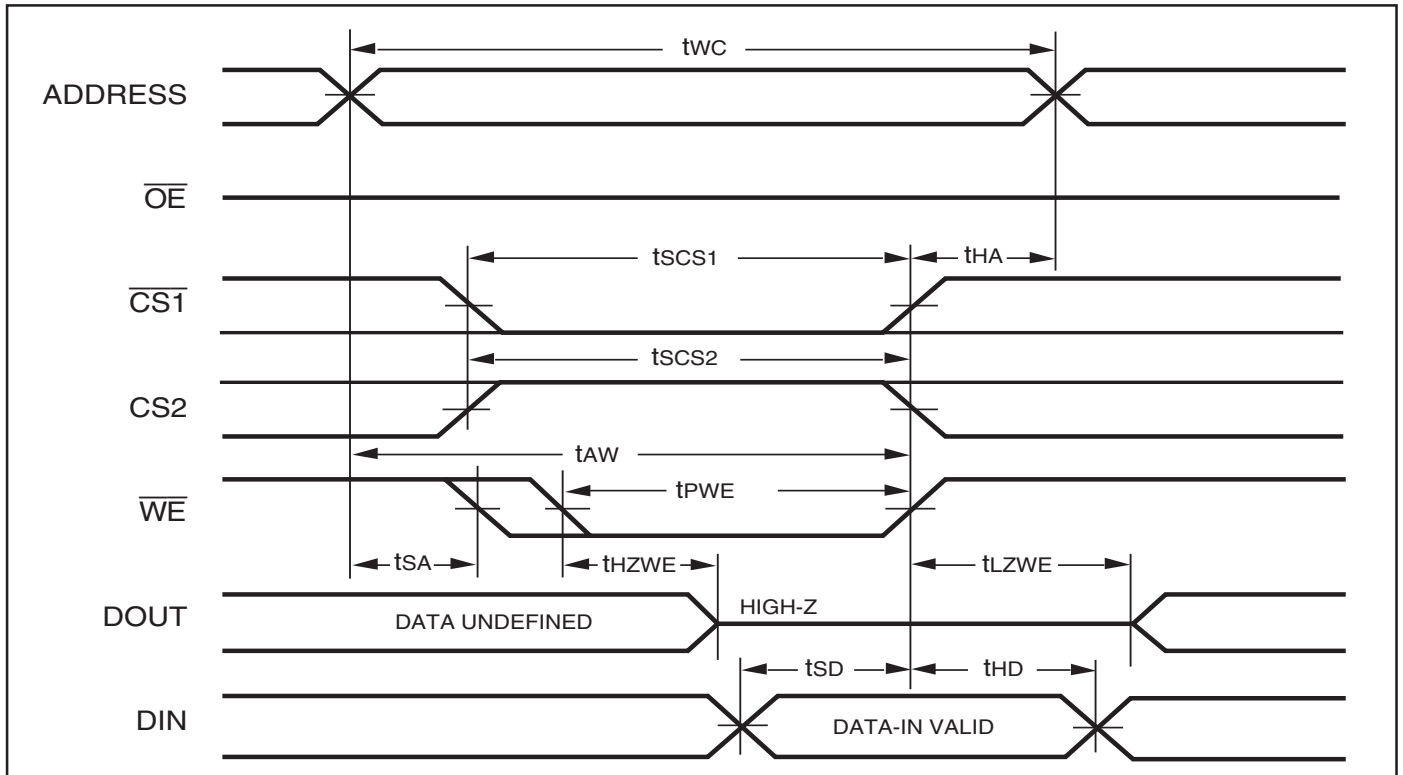

**DATA RETENTION SWITCHING CHARACTERISTICS**

Symbol	Parameter	Test Condition	Min.	Max.	Unit
V <sub>DR</sub>	V <sub>DD</sub> for Data Retention	See Data Retention Waveform	1.2	3.6	V
I <sub>DR</sub>	Data Retention Current	V <sub>DD</sub> = 1.2V, $\overline{CS1} \geq V_{DD} - 0.2V$	—	20	μA
t <sub>SDR</sub>	Data Retention Setup Time	See Data Retention Waveform	0	—	ns
t <sub>RDR</sub>	Recovery Time	See Data Retention Waveform	t <sub>rc</sub>	—	ns

**DATA RETENTION WAVEFORM ( $\overline{CS1}$  Controlled)**

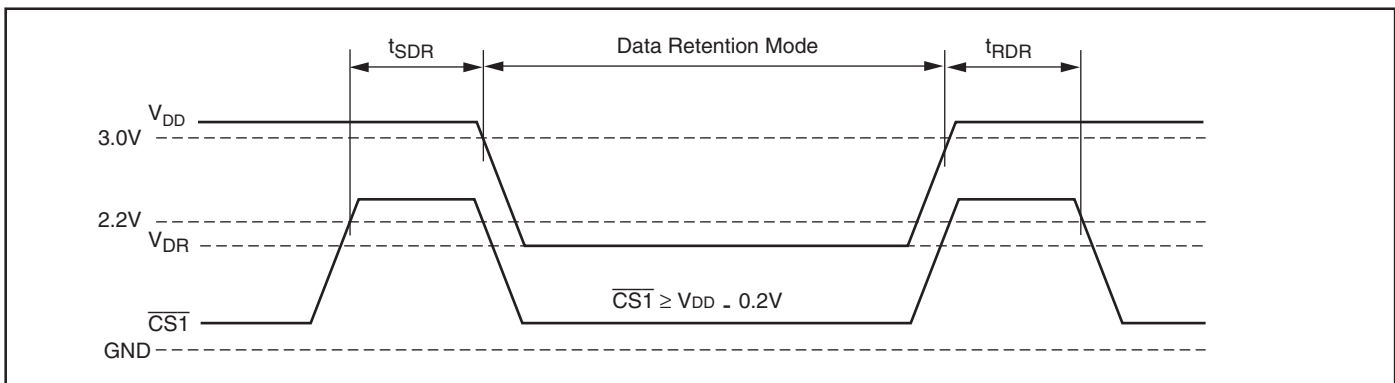

**DATA RETENTION WAVEFORM (CS2 Controlled)**

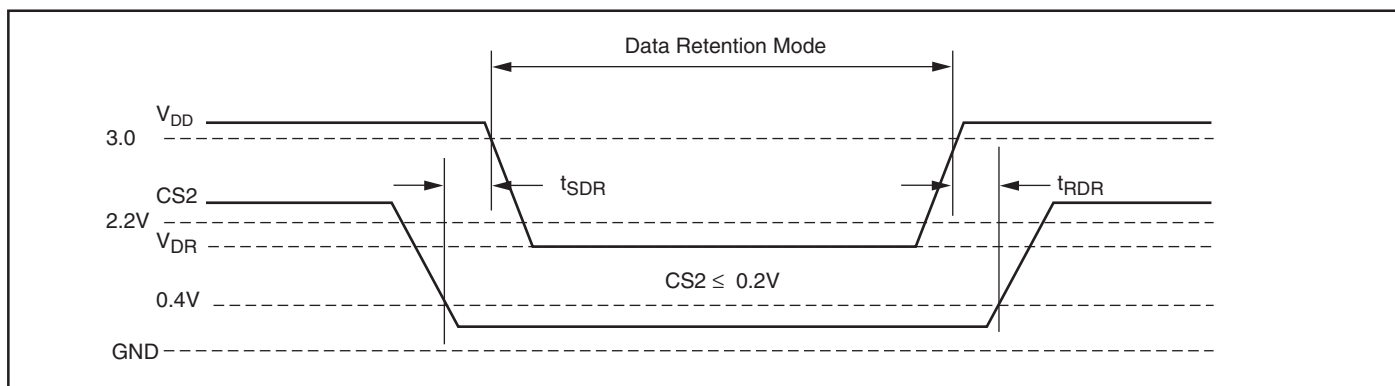

**ORDERING INFORMATION: IS62WV10248BLL (2.5V - 3.6V)****Industrial Range: -40°C to +85°C**

<b>Speed (ns)</b>	<b>Order Part No.</b>	<b>Package</b>
55	IS62WV10248BLL-55BI	mini BGA (7.2mm x 8.7mm)
	IS62WV10248BLL-55BLI	mini BGA (7.2mm x 8.7mm), Lead-free
70	IS62WV10248BLL-70BI	mini BGA (7.2mm x 8.7mm)
70	IS62WV10248BLL-70XI	DIE

Mini Ball Grid Array  
 Package Code: B (48-pin)

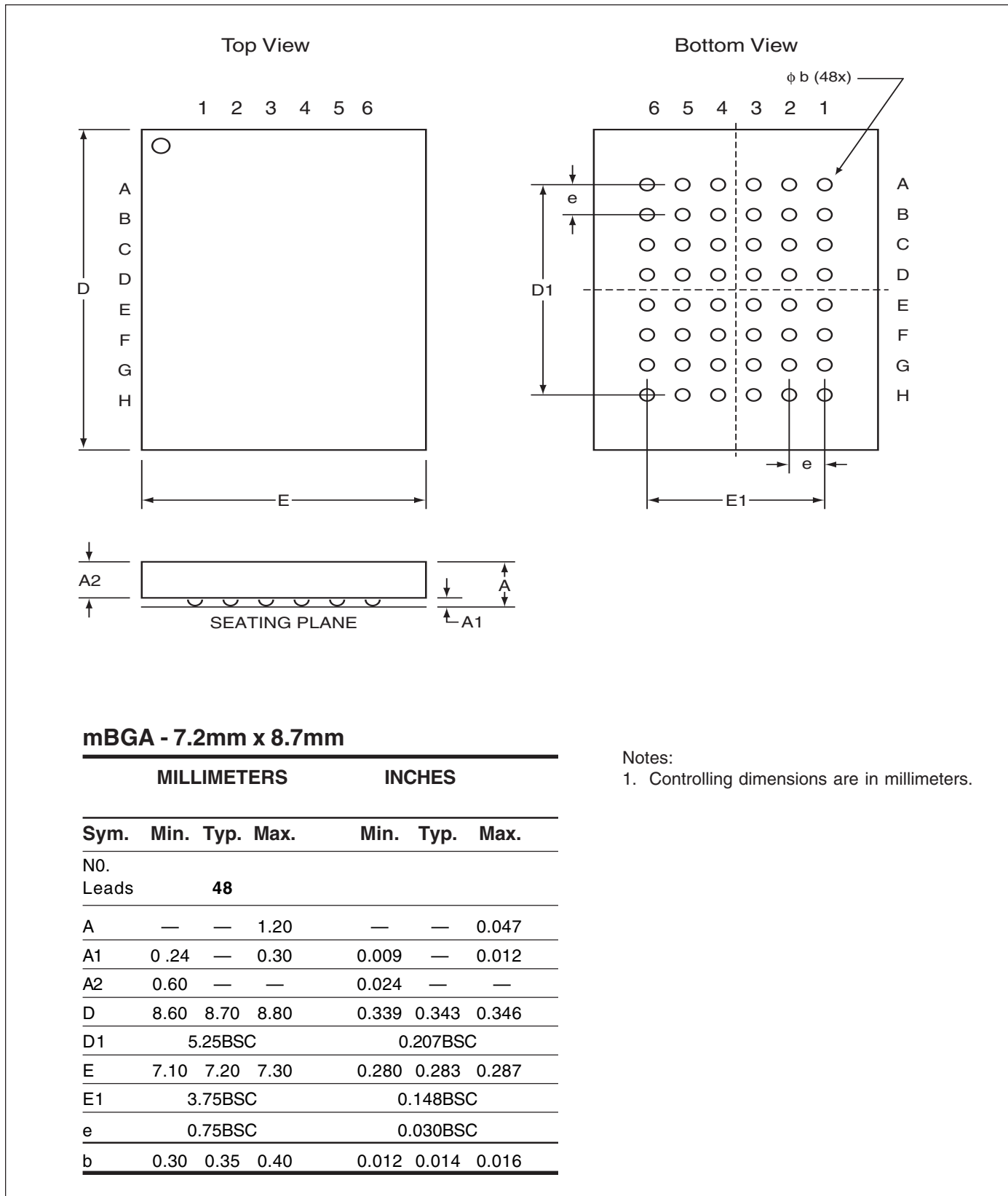

## X-ON Electronics

Largest Supplier of Electrical and Electronic Components

*Click to view similar products for [SRAM](#) category:*

*Click to view products by [ISSI](#) manufacturer:*

Other Similar products are found below :

[CY6116A-35DMB](#) [CY7C1049GN-10VXI](#) [CY7C128A-45DMB](#) [GS8161Z36DD-200I](#) [GS88237CB-200I](#) [RMLV0408EGSB-4S2#AA0](#)  
[IDT70V5388S166BG](#) [IS64WV3216BLL-15CTLA3](#) [IS66WVE4M16ECLL-70BLI](#) [PCF8570P](#) [K6F2008V2E-LF70000](#) [K6T4008C1B-GB70](#)  
[CY7C1353S-100AXC](#) [AS6C8016-55BIN](#) [AS7C164A-15PCN](#) [515712X](#) [IDT71V67603S133BG](#) [IS62WV51216EBLL-45BLI](#)  
[IS63WV1288DBLL-10HLI](#) [IS66WVE2M16ECLL-70BLI](#) [IS66WVE4M16EALL-70BLI](#) [IS62WV6416DBLL-45BLI](#) [IS61WV102416DBLL-](#)  
[10TLI](#) [CY7C1381KV33-100AXC](#) [CY7C1381KVE33-133AXI](#) [8602501XA](#) [5962-3829425MUA](#) [5962-3829430MUA](#) [5962-8855206YA](#)  
[5962-8866201YA](#) [5962-8866204TA](#) [5962-8866206MA](#) [5962-8866208UA](#) [5962-8872502XA](#) [5962-9062007MXA](#) [5962-9161705MXA](#)  
[GS882Z18CD-150I](#) [M38510/28902BVA](#) [8413202RA](#) [5962-9161708MYA](#) [5962-8971203XA](#) [5962-8971202ZA](#) [5962-8872501LA](#) [5962-](#)  
[8866208YA](#) [5962-8866205YA](#) [5962-8866205UA](#) [5962-8866203YA](#) [5962-8855202YA](#) [5962-8751309VA](#) [5962-8687519XA](#)