

512K x 8 LOW VOLTAGE, ULTRA LOW POWER CMOS STATIC RAM

JANUARY 2008

FEATURES

- High-speed access time: 55ns, 70ns
- CMOS low power operation
 - 36 mW (typical) operating
 - 9 μ W (typical) CMOS standby
- TTL compatible interface levels
- Single power supply
 - 1.65V – 2.2V V_{DD} (IS62WV5128ALL)
 - 2.5V – 3.6V V_{DD} (IS62WV5128BLL)
- Fully static operation: no clock or refresh required
- Three state outputs
- Industrial temperature available
- Lead-free available

DESCRIPTION

The *ISSI* IS62WV5128ALL / IS62WV5128BLL are high-speed, 4M bit static RAMs organized as 512K words by 8 bits. It is fabricated using *ISSI*'s high-performance CMOS technology. This highly reliable process coupled with innovative circuit design techniques, yields high-performance and low power consumption devices.

When $\overline{CS1}$ is HIGH (deselected) the device assumes a standby mode at which the power dissipation can be reduced down with CMOS input levels.

Easy memory expansion is provided by using Chip Enable and Output Enable inputs. The active LOW Write Enable (\overline{WE}) controls both writing and reading of the memory.

The IS62WV5128ALL and IS62WV5128BLL are packaged in the JEDEC standard 32-pin TSOP (TYPE I), 32-pin sTSOP (TYPE I), 32-pin TSOP (Type II), 32-pin SOP and 36-pin mini BGA.

FUNCTIONAL BLOCK DIAGRAM

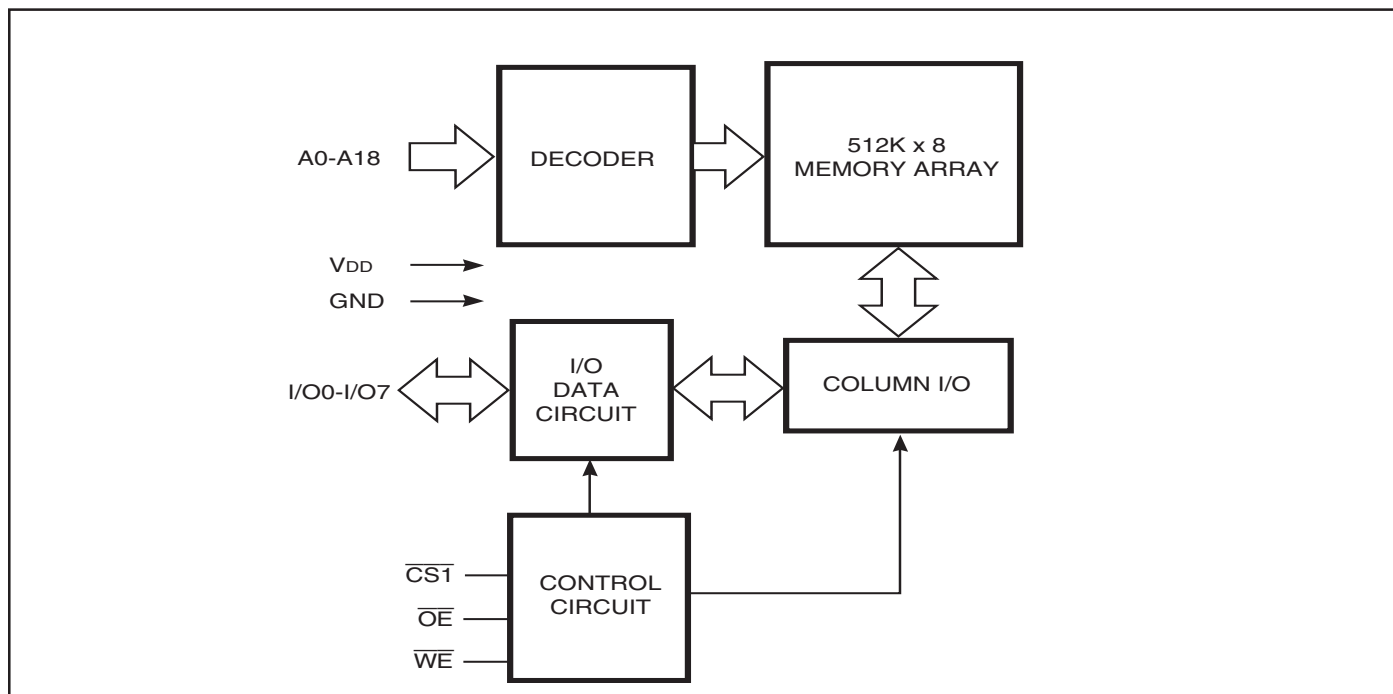

Copyright © 2005 Integrated Silicon Solution, Inc. All rights reserved. ISSI reserves the right to make changes to this specification and its products at any time without notice. ISSI assumes no liability arising out of the application or use of any information, products or services described herein. Customers are advised to obtain the latest version of this device specification before relying on any published information and before placing orders for products.

PIN DESCRIPTIONS

A0-A18	Address Inputs
$\overline{CS1}$	Chip Enable 1 Input
\overline{OE}	Output Enable Input
\overline{WE}	Write Enable Input
I/O0-I/O7	Input/Output
NC	No Connection
VDD	Power
GND	Ground

**36-pin mini BGA (B) (6mm x 8mm)
(Package Code B)**

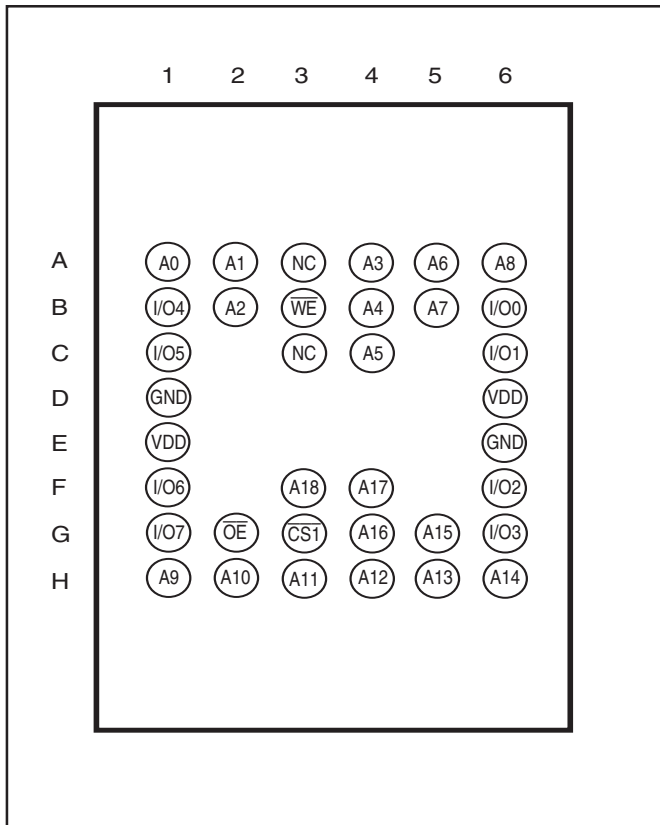

PIN DESCRIPTIONS

A0-A18	Address Inputs
$\overline{CS1}$	Chip Enable 1 Input
\overline{OE}	Output Enable Input
\overline{WE}	Write Enable Input
I/O0-I/O7	Input/Output
V _{DD}	Power
GND	Ground

PIN CONFIGURATION

32-pin TSOP (TYPE I), (Package Code T)
32-pin sTSOP (TYPE I) (Package Code H)

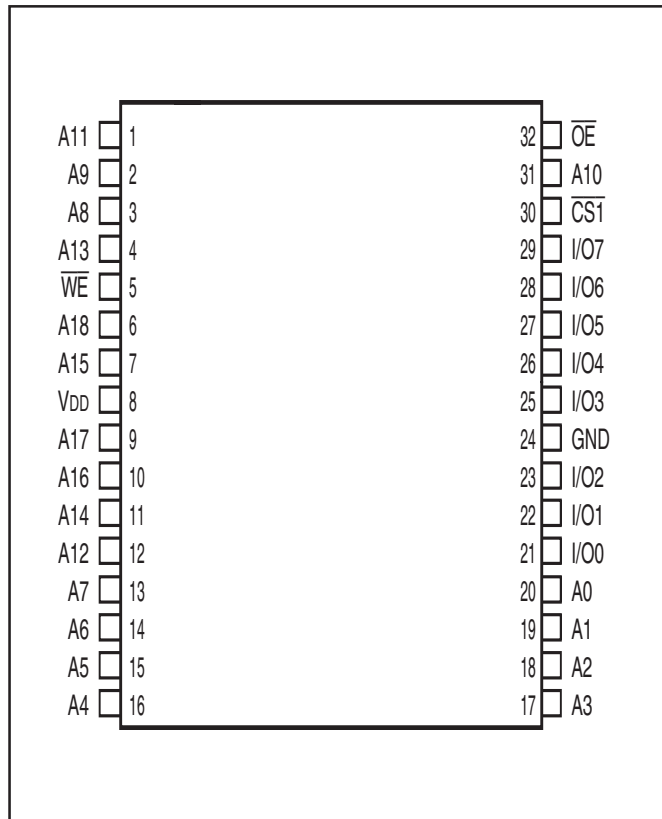

32-pin SOP (Package Code Q)
32-pin TSOP (TYPE II) (Package Code T2)

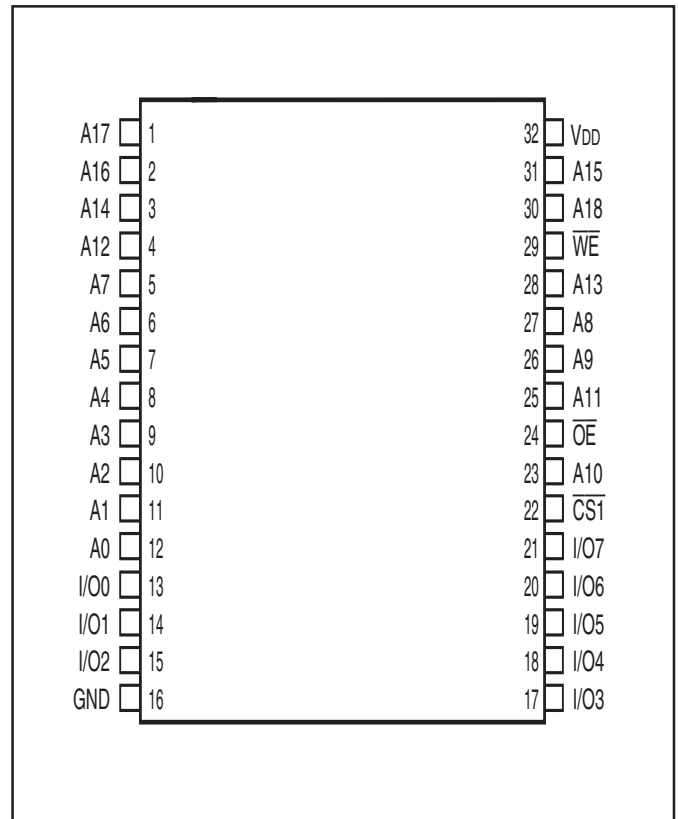



IS62WV5128ALL, IS62WV5128BLL

OPERATING RANGE (V_{DD})

Range	Ambient Temperature	IS62WV5128ALL	IS62WV5128BLL
Commercial	0°C to +70°C	1.65V - 2.2V	2.5V - 3.6V
Industrial	-40°C to +85°C	1.65V - 2.2V	2.5V - 3.6V

ABSOLUTE MAXIMUM RATINGS⁽¹⁾

Symbol	Parameter	Value	Unit
V _{TERM}	Terminal Voltage with Respect to GND	-0.2 to V _{DD} +0.3	V
V _{DD}	V _{DD} Related to GND	-0.2 to V _{DD} +0.3	V
T _{STG}	Storage Temperature	-65 to +150	°C
P _T	Power Dissipation	1.0	W

Note:

1. Stress greater than those listed under ABSOLUTE MAXIMUM RATINGS may cause permanent damage to the device. This is a stress rating only and functional operation of the device at these or any other conditions above those indicated in the operational sections of this specification is not implied. Exposure to absolute maximum rating conditions for extended periods may affect reliability.

DC ELECTRICAL CHARACTERISTICS (Over Operating Range)

Symbol	Parameter	Test Conditions	V _{DD}	Min.	Max.	Unit
V _{OH}	Output HIGH Voltage	I _{OH} = -0.1 mA	1.65-2.2V	1.4	—	V
		I _{OH} = -1 mA	2.5-3.6V	2.2	—	V
V _{OL}	Output LOW Voltage	I _{OL} = 0.1 mA	1.65-2.2V	—	0.2	V
		I _{OL} = 2.1 mA	2.5-3.6V	—	0.4	V
V _{IH}	Input HIGH Voltage		1.65-2.2V	1.4	V _{DD} + 0.2	V
			2.5-3.6V	2.2	V _{DD} + 0.3	V
V _{IL} ⁽¹⁾	Input LOW Voltage		1.65-2.2V	-0.2	0.4	V
			2.5-3.6V	-0.2	0.6	V
I _{LI}	Input Leakage	GND ≤ V _{IN} ≤ V _{DD}		-1	1	μA
I _{LO}	Output Leakage	GND ≤ V _{OUT} ≤ V _{DD} , Outputs Disabled		-1	1	μA

Notes:

1. V_{IL} (min.) = -1.0V for pulse width less than 10 ns.

CAPACITANCE⁽¹⁾

Symbol	Parameter	Conditions	Max.	Unit
C _{IN}	Input Capacitance	V _{IN} = 0V	8	pF
C _{OUT}	Input/Output Capacitance	V _{OUT} = 0V	10	pF

Note:

1. Tested initially and after any design or process changes that may affect these parameters.

AC TEST CONDITIONS

Parameter	IS62WV5128ALL (Unit)	IS62WV5128BLL (Unit)
Input Pulse Level	0.4V to V _{DD} -0.2V	0.4V to V _{DD} -0.3V
Input Rise and Fall Times	5 ns	5ns
Input and Output Timing and Reference Level	V _{REF}	V _{REF}
Output Load	See Figures 1 and 2	See Figures 1 and 2

	IS62WV5128ALL 1.65 - 2.2V	IS62WV5128BLL 2.5V - 3.6V
R1(Ω)	3070	3070
R2(Ω)	3150	3150
V _{REF}	0.9V	1.5V
V _{TM}	1.8V	2.8V

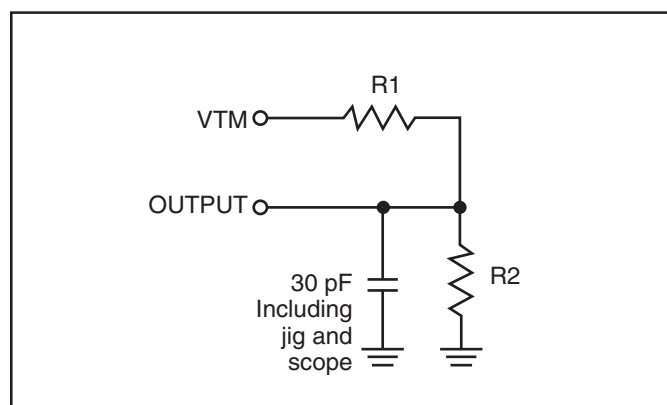
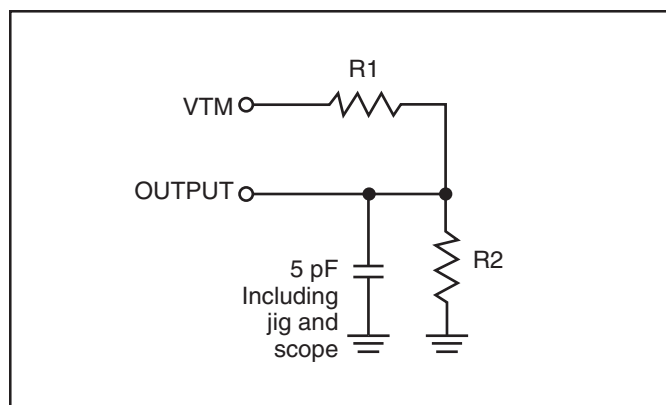
AC TEST LOADS

Figure 1

Figure 2

IS62WV5128ALL, IS62WV5128BLL

POWER SUPPLY CHARACTERISTICS⁽¹⁾ (Over Operating Range)

62WV5128ALL (1.65V - 2.2V)

Symbol	Parameter	Test Conditions		Max. 70 ns	Unit
I _{CC}	V _{DD} Dynamic Operating Supply Current	V _{DD} = Max., I _{OUT} = 0 mA, f = f _{MAX}	Com. Ind.	25 30	mA
I _{CC1}	Operating Supply Current	V _{DD} = Max., $\overline{CS1} = 0.2V$ $\overline{WE} = V_{DD} - 0.2V$ f = 1 MHz	Com. Ind.	10 10	mA
I _{SB1}	TTL Standby Current (TTL Inputs)	V _{DD} = Max., V _{IN} = V _{IH} or V _{IL} $\overline{CS1} = V_{IH}$, f = 1 MHz	Com. Ind.	0.35 0.35	mA
I _{SB2}	CMOS Standby Current (CMOS Inputs)	V _{DD} = Max., $\overline{CS1} \geq V_{DD} - 0.2V$, V _{IN} ≥ V _{DD} - 0.2V, or V _{IN} ≤ 0.2V, f = 0	Com. Ind.	15 15	μA

Note:

1. At f = f_{MAX}, address and data inputs are cycling at the maximum frequency, f = 0 means no input lines change.

POWER SUPPLY CHARACTERISTICS⁽¹⁾ (Over Operating Range)

62WV5128BLL (2.5V - 3.6V)

Symbol	Parameter	Test Conditions		Max. 55 ns	Unit
I _{CC}	V _{DD} Dynamic Operating Supply Current	V _{DD} = Max., I _{OUT} = 0 mA, f = f _{MAX}	Com. Ind.	40 45	mA
I _{CC1}	Operating Supply Current	V _{DD} = Max., $\overline{CS1} = 0.2V$ $\overline{WE} = V_{DD} - 0.2V$ f = 1 MHz	Com. Ind.	15 15	mA
I _{SB1}	TTL Standby Current (TTL Inputs)	V _{DD} = Max., V _{IN} = V _{IH} or V _{IL} $\overline{CS1} = V_{IH}$, f = 1 MHz	Com. Ind.	0.35 0.35	mA
I _{SB2}	CMOS Standby Current (CMOS Inputs)	V _{DD} = Max., $\overline{CS1} \geq V_{DD} - 0.2V$, V _{IN} ≥ V _{DD} - 0.2V, or V _{IN} ≤ 0.2V, f = 0	Com. Ind.	15 15	μA

Note:

1. At f = f_{MAX}, address and data inputs are cycling at the maximum frequency, f = 0 means no input lines change.

READ CYCLE SWITCHING CHARACTERISTICS⁽¹⁾ (Over Operating Range)

Symbol	Parameter	55 ns		70 ns		Unit
		Min.	Max.	Min.	Max.	
t_{RC}	Read Cycle Time	55	—	70	—	ns
t_{AA}	Address Access Time	—	55	—	70	ns
t_{OHA}	Output Hold Time	10	—	10	—	ns
t_{ACS1}	$\overline{CS1}$ Access Time	—	55	—	70	ns
t_{DOE}	\overline{OE} Access Time	—	25	—	35	ns
$t_{HZOE}^{(2)}$	\overline{OE} to High-Z Output	—	20	—	25	ns
$t_{LZOE}^{(2)}$	\overline{OE} to Low-Z Output	5	—	5	—	ns
t_{HZCS1}	$\overline{CS1}$ to High-Z Output	0	20	0	25	ns
t_{LZCS1}	$\overline{CS1}$ to Low-Z Output	10	—	10	—	ns

Notes:

1. Test conditions assume signal transition times of 5 ns or less, timing reference levels of 0.9V/1.5V, input pulse levels of 0.4 to $V_{DD}-0.2V/V_{DD}-0.3V$ and output loading specified in Figure 1.
2. Tested with the load in Figure 2. Transition is measured ± 500 mV from steady-state voltage. Not 100% tested.

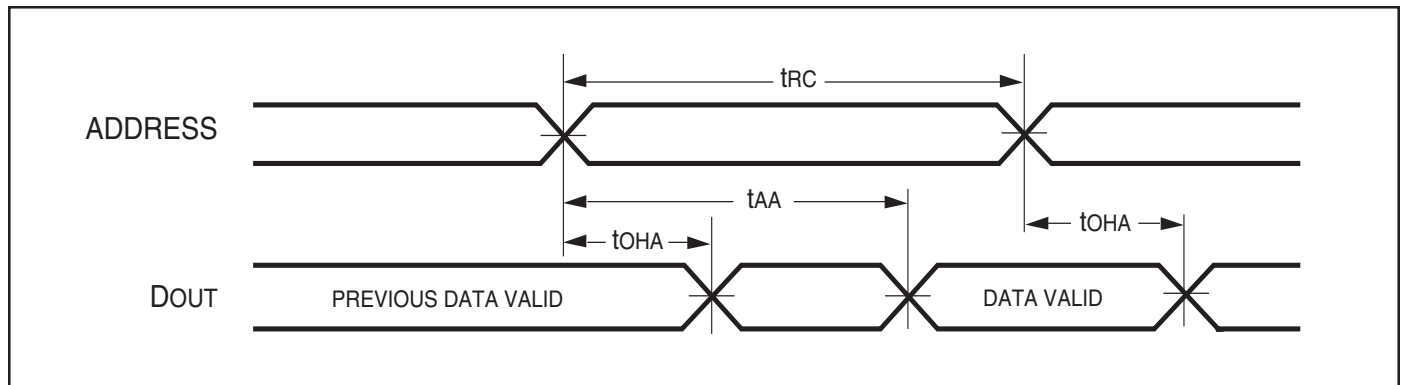
AC WAVEFORMS
READ CYCLE NO. 1^(1,2) (Address Controlled) ($\overline{CS1} = \overline{OE} = V_{IL}$, $\overline{WE} = V_{IH}$)

AC WAVEFORMS

READ CYCLE NO. 2^(1,3) ($\overline{CS1}$, \overline{OE} Controlled)

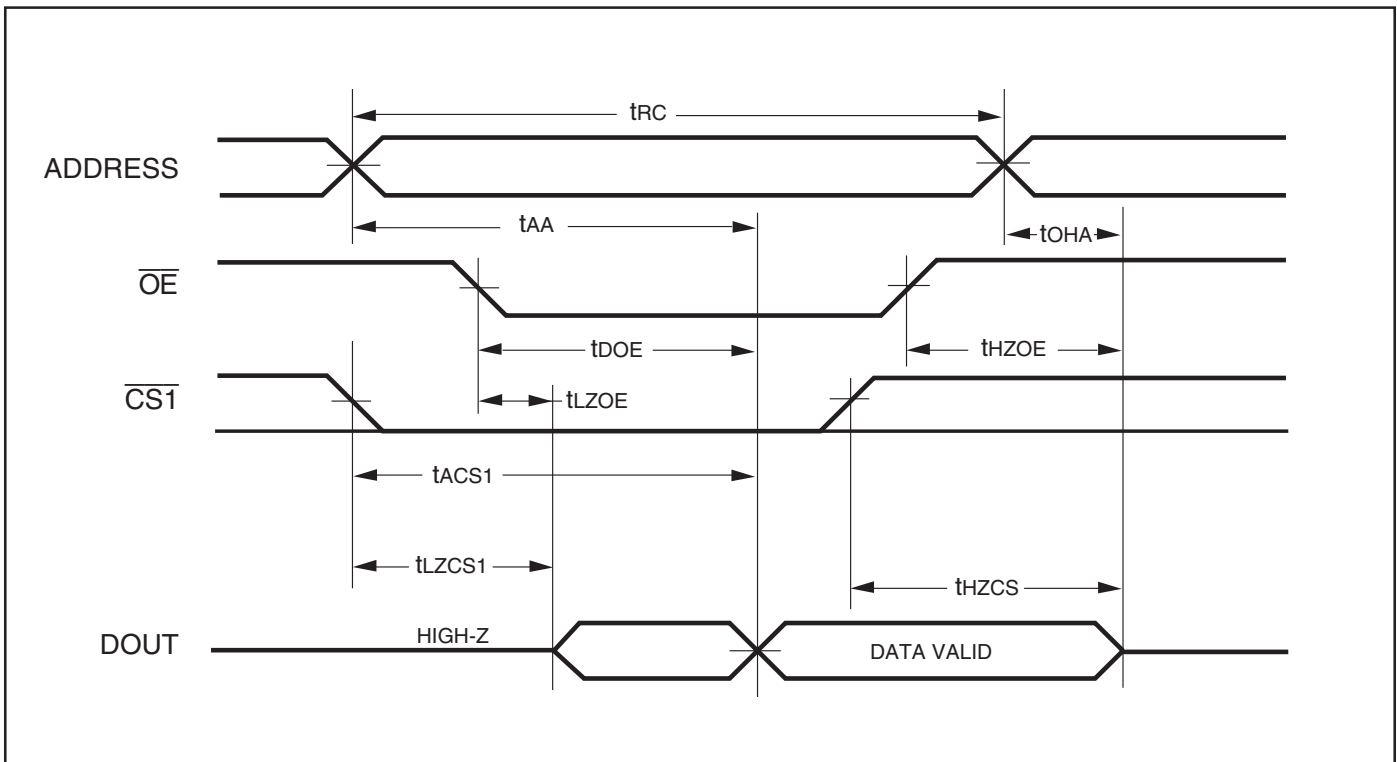

Notes:

1. \overline{WE} is HIGH for a Read Cycle.
2. The device is continuously selected. \overline{OE} , $\overline{CS1} = V_{IL}$. $\overline{WE} = V_{IH}$.
3. Address is valid prior to or coincident with $\overline{CS1}$ LOW transition.

WRITE CYCLE SWITCHING CHARACTERISTICS^(1,2) (Over Operating Range)

Symbol	Parameter	55 ns		70 ns		Unit
		Min.	Max.	Min.	Max.	
t_{WC}	Write Cycle Time	55	—	70	—	ns
t_{SCS1}	$\overline{CS1}$ to Write End	45	—	60	—	ns
t_{AW}	Address Setup Time to Write End	45	—	60	—	ns
t_{HA}	Address Hold from Write End	0	—	0	—	ns
t_{SA}	Address Setup Time	0	—	0	—	ns
t_{PWE}	\overline{WE} Pulse Width	40	—	50	—	ns
t_{SD}	Data Setup to Write End	25	—	30	—	ns
t_{HD}	Data Hold from Write End	0	—	0	—	ns
$t_{HZWE}^{(3)}$	\overline{WE} LOW to High-Z Output	—	20	—	20	ns
$t_{LZWE}^{(3)}$	\overline{WE} HIGH to Low-Z Output	5	—	5	—	ns

Notes:

1. Test conditions assume signal transition times of 5 ns or less, timing reference levels of 0.9V/1.5V, input pulse levels of 0.4V to $V_{DD}-0.2V/V_{DD}-0.3V$ and output loading specified in Figure 1.
2. The internal write time is defined by the overlap of $\overline{CS1}$ LOW and \overline{WE} LOW. All signals must be in valid states to initiate a Write, but any one can go inactive to terminate the Write. The Data Input Setup and Hold timing are referenced to the rising or falling edge of the signal that terminates the write.
3. Tested with the load in Figure 2. Transition is measured ± 500 mV from steady-state voltage. Not 100% tested.

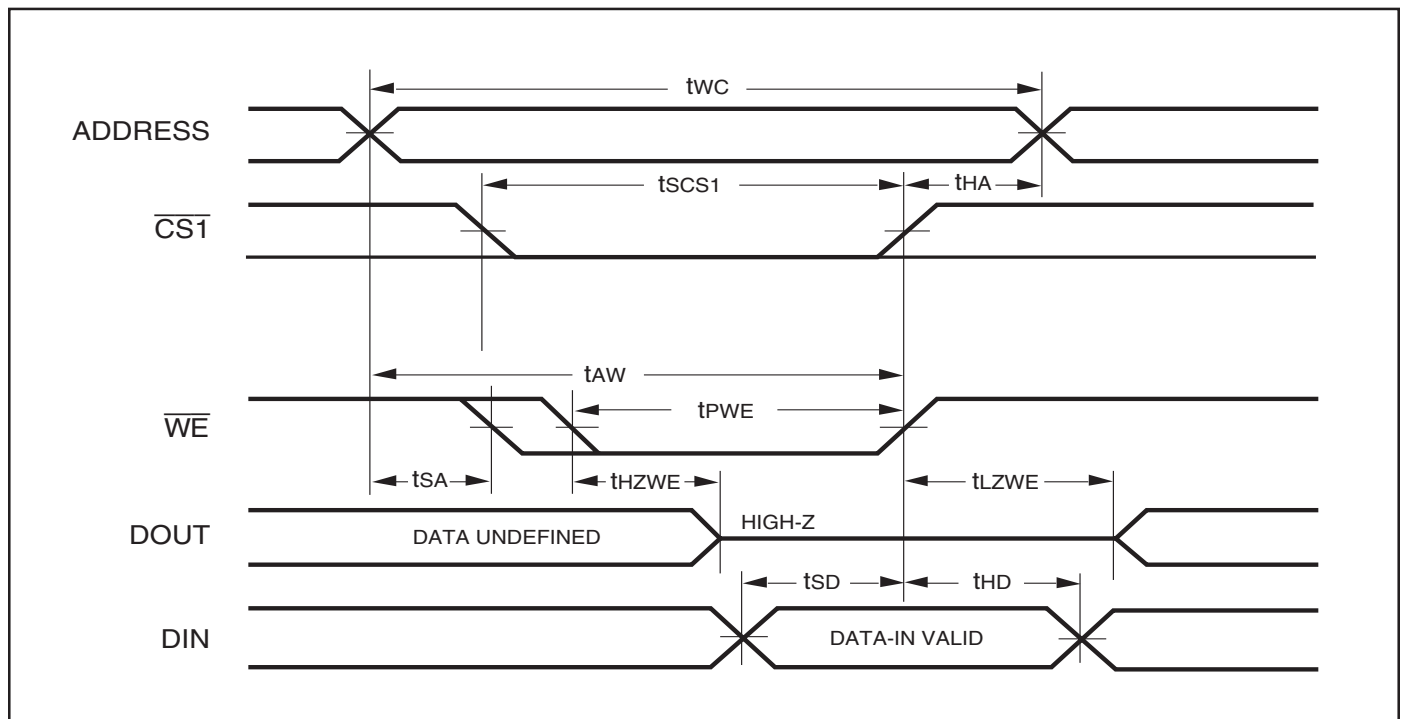
AC WAVEFORMS
WRITE CYCLE NO. 1 ($\overline{CS1}$ Controlled, \overline{OE} = HIGH or LOW)

WRITE CYCLE NO. 2 (\overline{WE} Controlled: \overline{OE} is HIGH During Write Cycle)

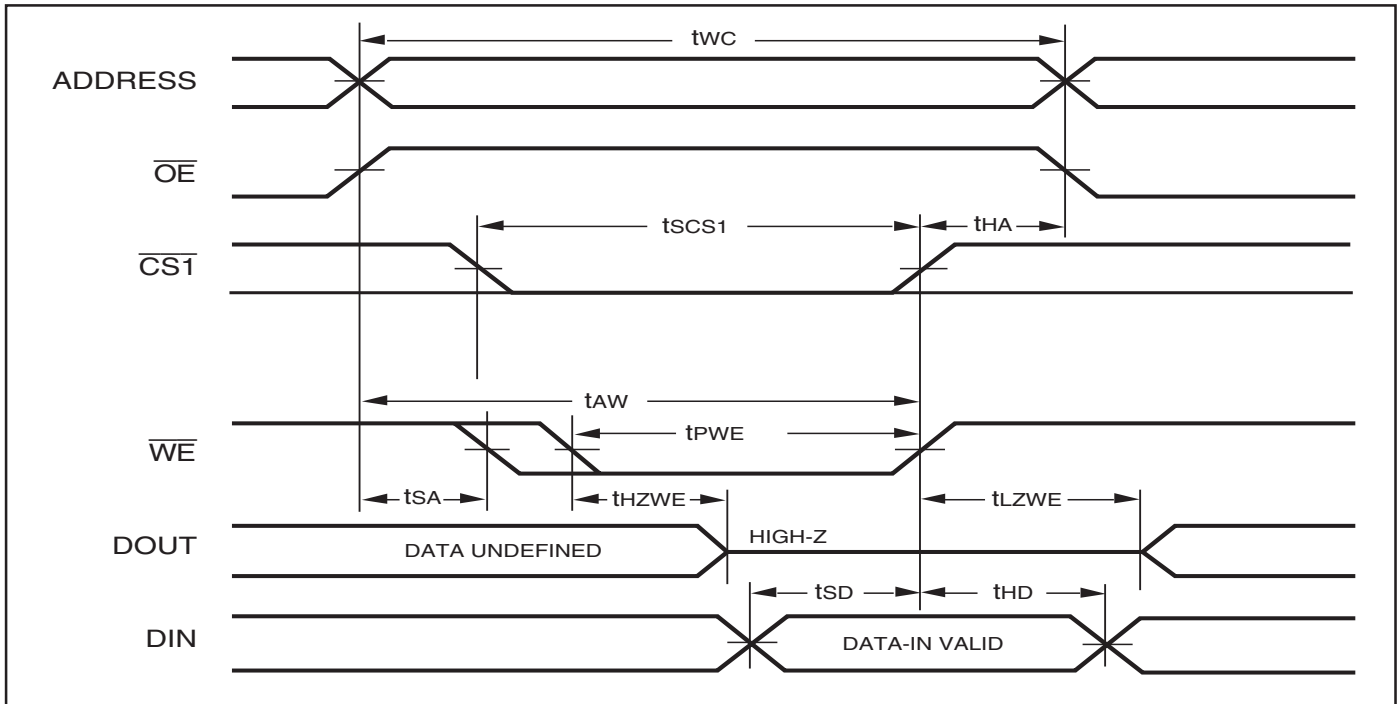

WRITE CYCLE NO. 3 (\overline{WE} Controlled: \overline{OE} is LOW During Write Cycle)

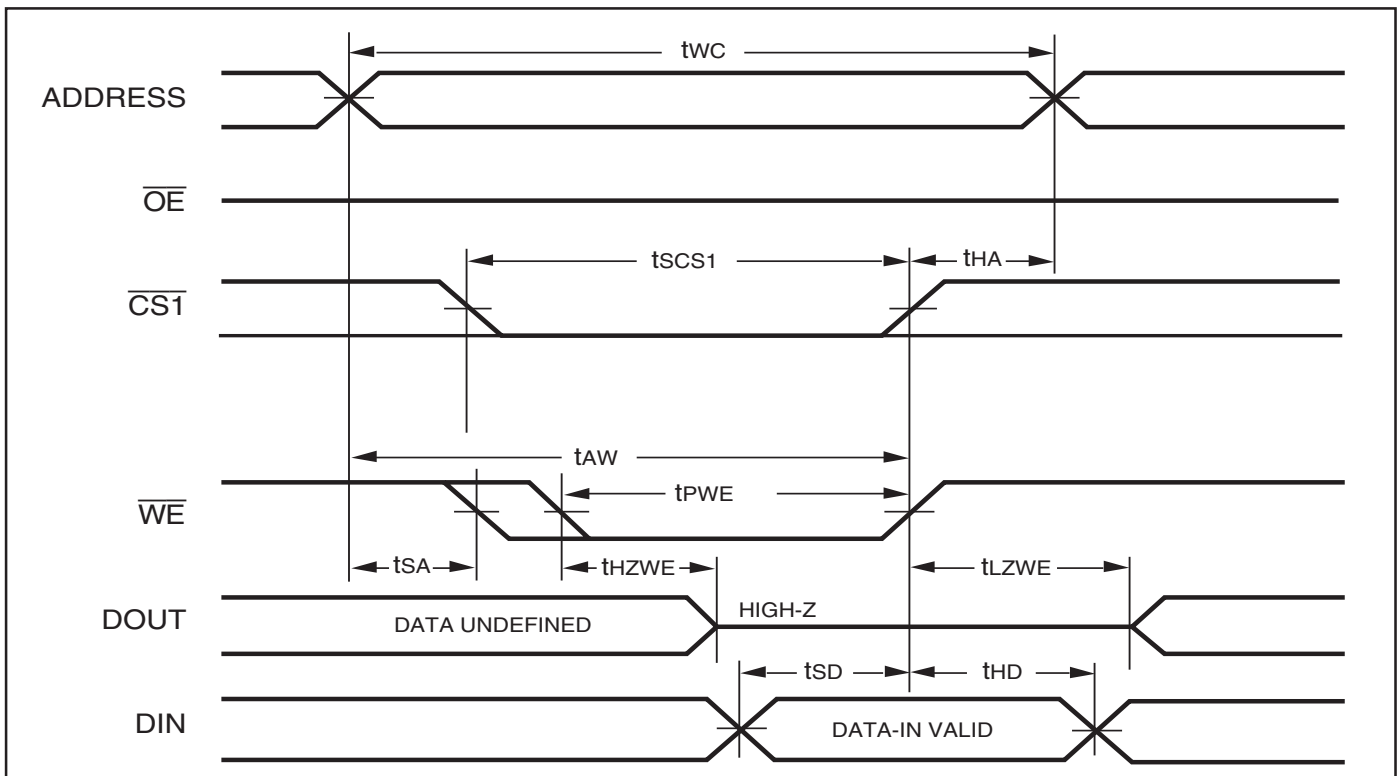

DATA RETENTION SWITCHING CHARACTERISTICS

Symbol	Parameter	Test Condition	Min.	Max.	Unit
V _{DR}	V _{DD} for Data Retention	See Data Retention Waveform	1.2	3.6	V
I _{DR}	Data Retention Current	V _{DD} = 1.2V, $\overline{CS1} \geq V_{DD} - 0.2V$	—	15	μA
t _{SDR}	Data Retention Setup Time	See Data Retention Waveform	0	—	ns
t _{RDR}	Recovery Time	See Data Retention Waveform	t _{rc}	—	ns

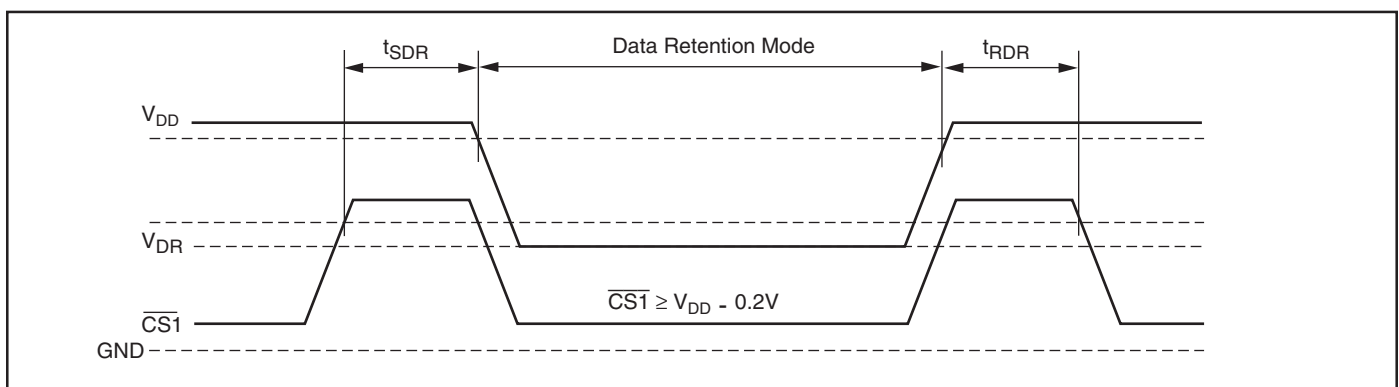
DATA RETENTION WAVEFORM ($\overline{CS1}$ Controlled)

IS62WV5128ALL, IS62WV5128BLL

ORDERING INFORMATION

IS62WV5128ALL (1.65V-2.2V)

Industrial Range: -40°C to +85°C

Speed (ns)	Order Part No.	Package
70	IS62WV5128ALL-70TI	TSOP, TYPE I
70	IS62WV5128ALL-70T2I	TSOP, TYPE II
70	IS62WV5128ALL-70HI	sTSOP, TYPE I
70	IS62WV5128ALL-70BI	mini BGA (6mmx8mm)

ORDERING INFORMATION

IS62WV5128BLL (2.5V - 3.6V)

Commercial Range: 0°C to +70°C

Speed (ns)	Order Part No.	Package
55	IS62WV5128BLL-55H	sTSOP, TYPE I

Industrial Range: -40°C to +85°C

Speed (ns)	Order Part No.	Package
55	IS62WV5128BLL-55TI	TSOP, TYPE I
55	IS62WV5128BLL-55TLI	TSOP, TYPE I, Lead-free
55	IS62WV5128BLL-55QLI	SOP, Lead-free
55	IS62WV5128BLL-55T2I	TSOP, TYPE II
55	IS62WV5128BLL-55T2LI	TSOP, TYPE II, Lead-free
55	IS62WV5128BLL-55HI	sTSOP, TYPE I
55	IS62WV5128BLL-55HLI	sTSOP, TYPE I, Lead-free
55	IS62WV5128BLL-55BI	mini BGA (6mmx8mm)
55	IS62WV5128BLL-55BLI	mini BGA (6mmx8mm), Lead-free

PACKAGING INFORMATION

Plastic TSOP
 Package Code: T (Type II)

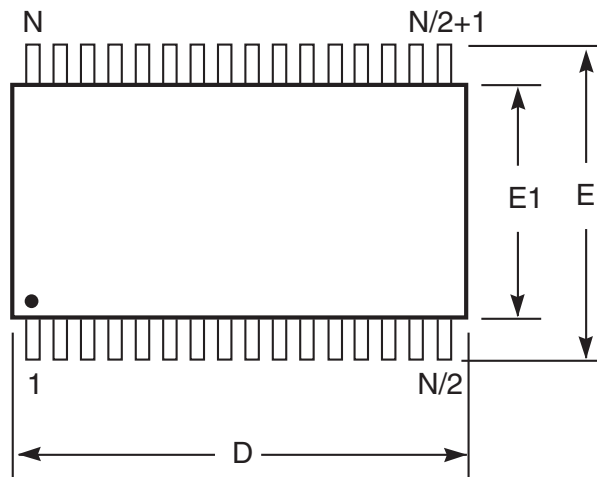

Notes:

1. Controlling dimension: millimeters, unless otherwise specified.
2. BSC = Basic lead spacing between centers.
3. Dimensions D and E1 do not include mold flash protrusions and should be measured from the bottom of the package.
4. Formed leads shall be planar with respect to one another within 0.004 inches at the seating plane.

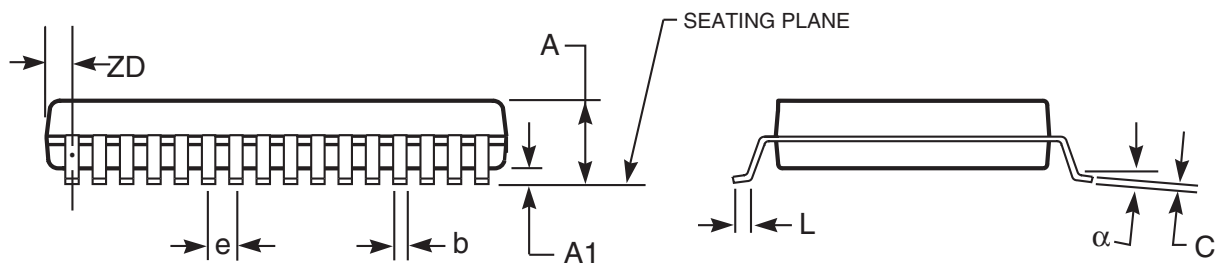

Plastic TSOP (T - Type II)

Symbol	Millimeters		Inches		Millimeters		Inches		Millimeters		Inches	
	Min	Max	Min	Max	Min	Max	Min	Max	Min	Max	Min	Max
Ref. Std.												
No. Leads (N)	32				44				50			
A	—	1.20	—	0.047	—	1.20	—	0.047	—	1.20	—	0.047
A1	0.05	0.15	0.002	0.006	0.05	0.15	0.002	0.006	0.05	0.15	0.002	0.006
b	0.30	0.52	0.012	0.020	0.30	0.45	0.012	0.018	0.30	0.45	0.012	0.018
C	0.12	0.21	0.005	0.008	0.12	0.21	0.005	0.008	0.12	0.21	0.005	0.008
D	20.82	21.08	0.820	0.830	18.31	18.52	0.721	0.729	20.82	21.08	0.820	0.830
E1	10.03	10.29	0.391	0.400	10.03	10.29	0.395	0.405	10.03	10.29	0.395	0.405
E	11.56	11.96	0.451	0.466	11.56	11.96	0.455	0.471	11.56	11.96	0.455	0.471
e	1.27 BSC		0.050 BSC		0.80 BSC		0.032 BSC		0.80 BSC		0.031 BSC	
L	0.40	0.60	0.016	0.024	0.41	0.60	0.016	0.024	0.40	0.60	0.016	0.024
ZD	0.95 REF		0.037 REF		0.81 REF		0.032 REF		0.88 REF		0.035 REF	
α	0°	5°	0°	5°	0°	5°	0°	5°	0°	5°	0°	5°

Copyright © 2003 Integrated Silicon Solution, Inc. All rights reserved. ISSI reserves the right to make changes to this specification and its products at any time without notice. ISSI assumes no liability arising out of the application or use of any information, products or services described herein. Customers are advised to obtain the latest version of this device specification before relying on any published information and before placing orders for products.

PACKAGING INFORMATION

Plastic TSOP-Type I

Package Code: T (32-pin)

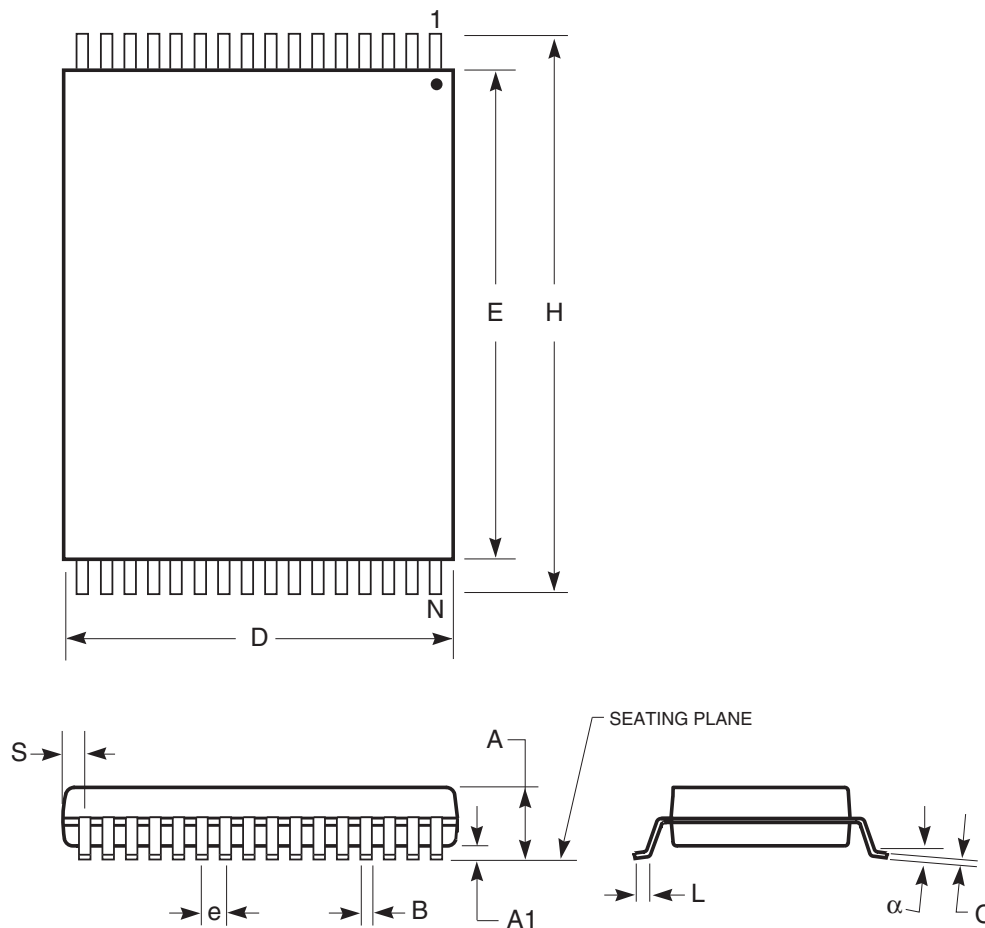

Symbol	MILLIMETERS		INCHES	
	Min.	Max.	Min.	Max.
No. Leads	32			
A	—	1.20	—	0.047
A1	0.05	0.25	0.002	0.010
B	0.17	0.23	0.007	0.009
C	0.12	0.17	0.005	0.007
D	7.90	8.10	0.311	0.319
E	18.30	18.50	0.720	0.728
H	19.80	20.20	0.780	0.795
e	0.50 BSC		0.020 BSC	
L	0.40	0.60	0.016	0.024
alpha	0°	8°	0°	8°
S	0.25 REF		0.010 REF	

Notes:

1. Controlling dimension: millimeters, unless otherwise specified.
2. BSC = Basic lead spacing between centers.
3. Dimensions D and E do not include mold flash protrusions and should be measured from the bottom of the package.
4. Formed leads shall be planar with respect to one another within 0.004 inches at the seating plane.

PACKAGING INFORMATION

450-mil Plastic SOP
 Package Code: Q (32-pin)

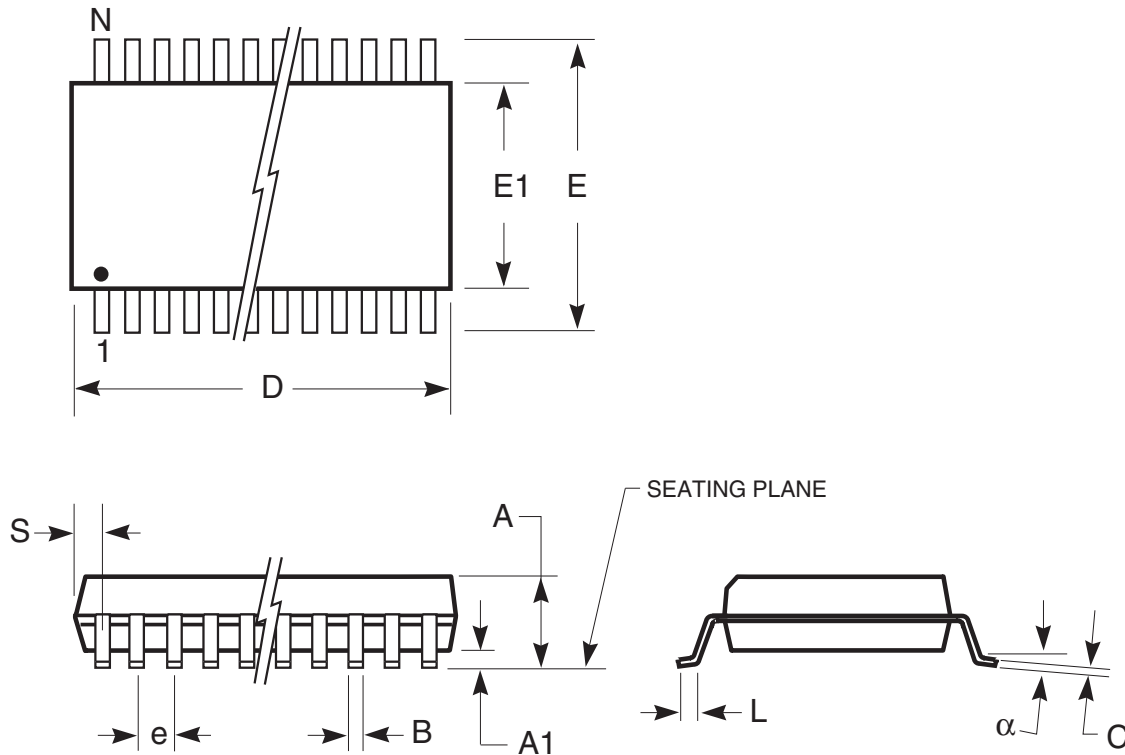

	MILLIMETERS		INCHES	
Symbol	Min.	Max.	Min.	Max.
No. Leads	32			
A	—	3.00	—	0.118
A1	0.10	—	0.004	—
B	0.36	0.51	0.014	0.020
C	0.15	0.30	0.006	0.012
D	20.14	20.75	0.793	0.817
E	13.87	14.38	0.546	0.566
E1	11.18	11.43	0.440	0.450
e	1.27 BSC		0.050 BSC	
L	0.58	0.99	0.023	0.039
α	0°	10°	0°	10°
S	—	0.86	—	0.034

Notes:

1. Controlling dimension: inches, unless otherwise specified.
2. BSC = Basic lead spacing between centers.
3. Dimensions D and E1 do not include mold flash protrusions and should be measured from the bottom of the package.
4. Formed leads shall be planar with respect to one another within 0.004 inches at the seating plane.

Copyright © 2003 Integrated Silicon Solution, Inc. All rights reserved. ISSI reserves the right to make changes to this specification and its products at any time without notice. ISSI assumes no liability arising out of the application or use of any information, products or services described herein. Customers are advised to obtain the latest version of this device specification before relying on any published information and before placing orders for products.

PACKAGING INFORMATION

Plastic STSOP - 32 pins

Package Code: H (Type I)

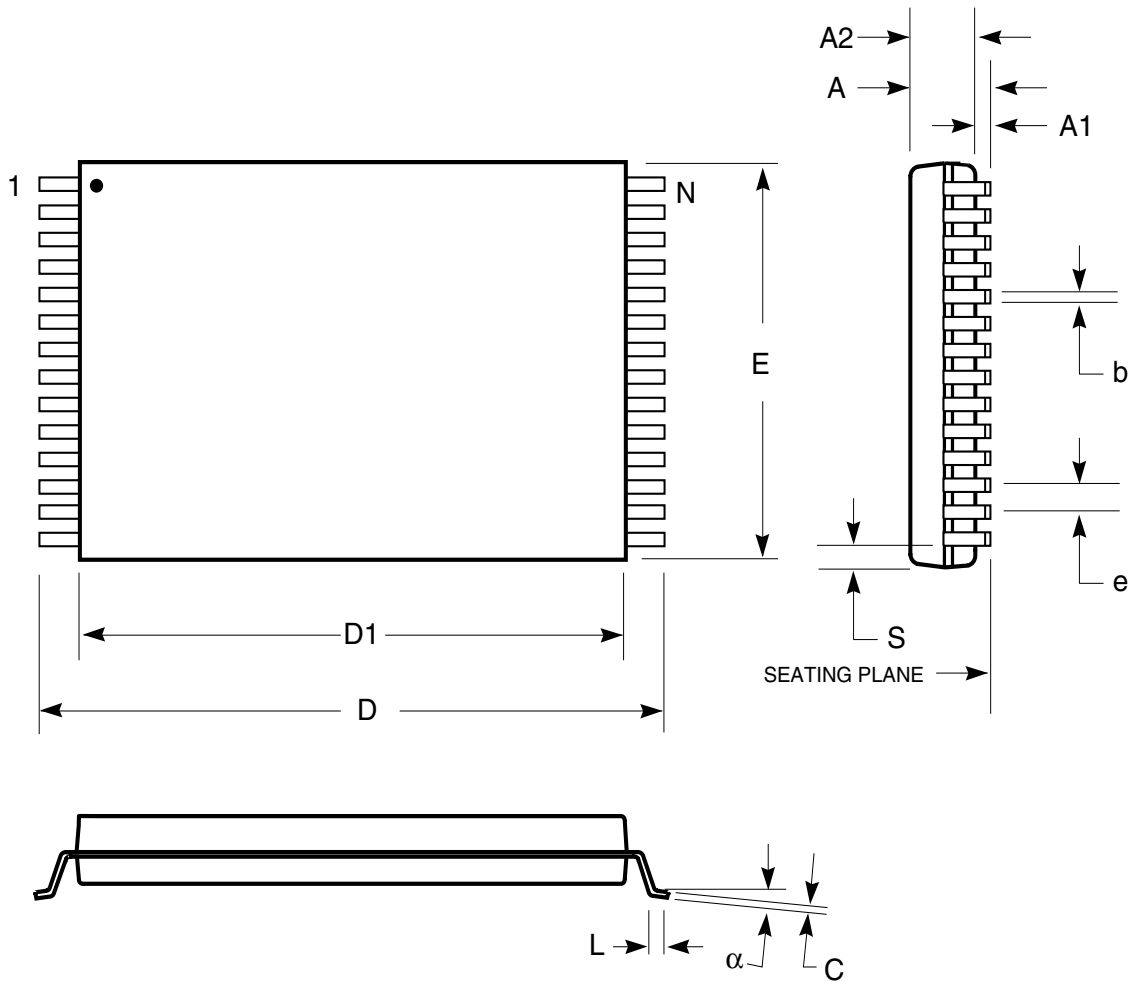

Plastic STSOP (H - Type I)				
	Millimeters		Inches	
Symbol	Min	Max	Min	Max
Ref. Std.				
N	32			
A	—	1.25	—	0.049
A1	0.05	—	0.002	—
A2	0.95	1.05	0.037	0.041
b	0.17	0.23	0.007	0.009
C	0.14	0.16	0.0055	0.0063
D	13.20	13.60	0.520	0.535
D1	11.70	11.90	0.461	0.469
E	7.90	8.10	0.311	0.319
e	0.50 BSC		0.020 BSC	
L	0.30	0.70	0.012	0.028
S	0.28 Typ.		0.011 Typ.	
alpha	0°	5°	0°	5°

Notes:

1. Controlling dimension: millimeters, unless otherwise specified.
2. BSC = Basic lead spacing between centers.
3. Dimensions D1 and E do not include mold flash protrusions and should be measured from the bottom of the package.
4. Formed leads shall be planar with respect to one another within 0.004 inches at the seating plane.

PACKAGING INFORMATION

Mini Ball Grid Array Package Code: B (36-pin)

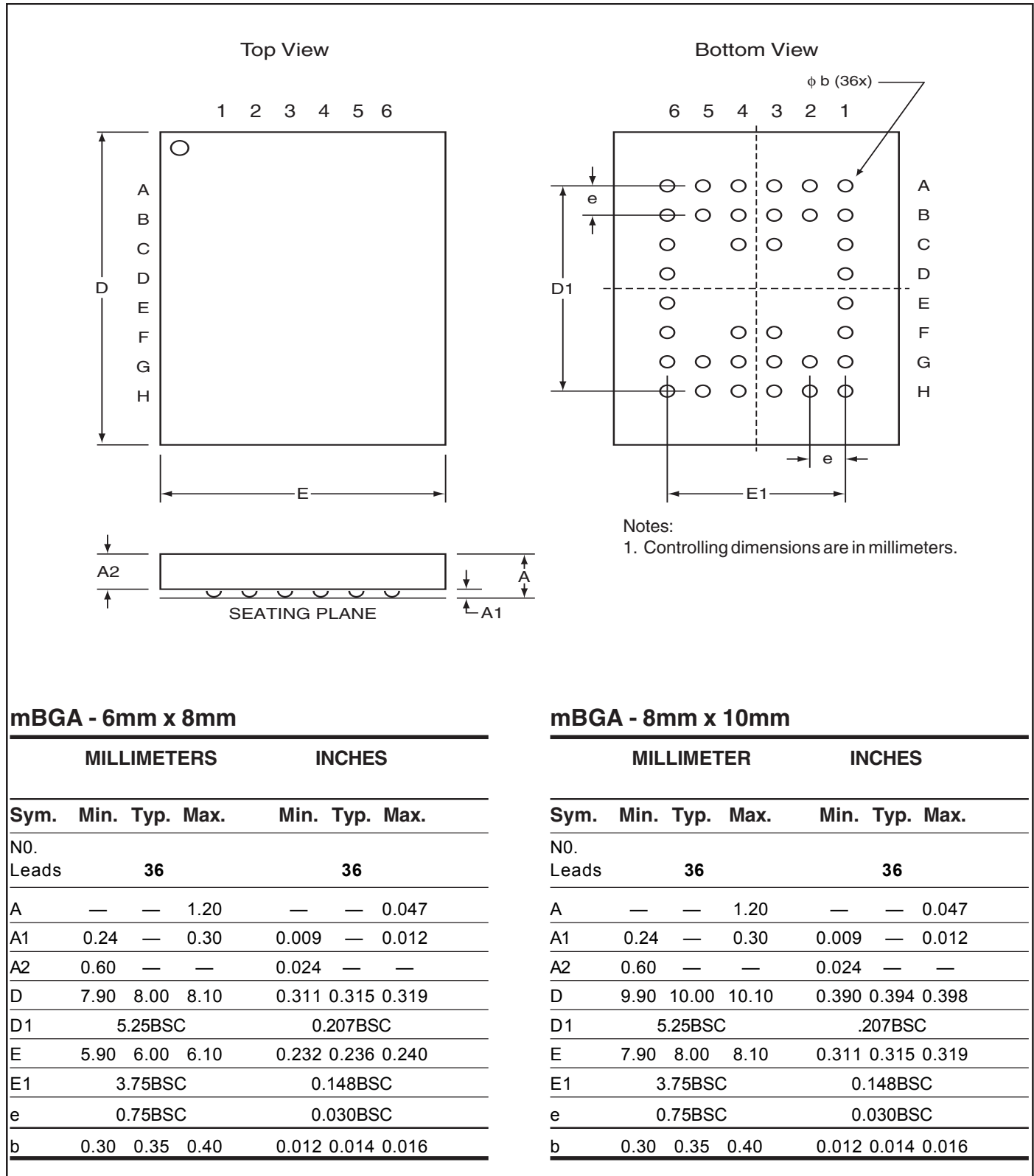

Copyright © 2003 Integrated Silicon Solution, Inc. All rights reserved. ISSI reserves the right to make changes to this specification and its products at any time without notice. ISSI assumes no liability arising out of the application or use of any information, products or services described herein. Customers are advised to obtain the latest version of this device specification before relying on any published information and before placing orders for products.

X-ON Electronics

Largest Supplier of Electrical and Electronic Components

Click to view similar products for [SRAM](#) category:

Click to view products by [ISSI](#) manufacturer:

Other Similar products are found below :

[5962-8855206XA](#) [CY6116A-35DMB](#) [CY7C128A-45DMB](#) [CY7C1461KV33-133AXI](#) [CY7C199-45LMB](#) [CYDM128B16-55BVXIT](#)
[GS8161Z36DD-200I](#) [GS88237CB-200I](#) [R1QDA7236ABB-20IB0](#) [RMLV0408EGSB-4S2#AA0](#) [IS64WV3216BLL-15CTLA3](#)
[IS66WVE4M16ECLL-70BLI](#) [PCF8570P](#) [K6T4008C1B-GB70](#) [CY7C1353S-100AXC](#) [AS6C8016-55BIN](#) [515712X](#) [IS62WV51216EBLL-](#)
[45BLI](#) [IS63WV1288DBLL-10HLI](#) [IS66WVE2M16ECLL-70BLI](#) [47L16-E/SN](#) [IS66WVE4M16EALL-70BLI](#) [IS62WV6416DBLL-45BLI](#)
[IS61WV102416DBLL-10TLI](#) [CY7C1381KV33-100AXC](#) [CY7C1381KV33-100BZXI](#) [CY7C1373KV33-100AXC](#) [CY7C1381KVE33-133AXI](#)
[CY7C4042KV13-933FCXC](#) [8602501XA](#) [5962-3829425MUA](#) [5962-8855206YA](#) [5962-8866201XA](#) [5962-8866201YA](#) [5962-8866204TA](#)
[5962-8866206MA](#) [5962-8866207NA](#) [5962-8866208UA](#) [5962-8872502XA](#) [5962-8959836MZA](#) [5962-8959841MZA](#) [5962-9062007MXA](#)
[5962-9161705MXA](#) [N08L63W2AB7I](#) [7130LA100PDG](#) [GS882Z18CD-150I](#) [GS81284Z36B-250I](#) [M38510/28902BVA](#) [IS62WV12816ALL-](#)
[70BLI](#) [5962-8971203XA](#)