



IS66WVO8M8DALL/BLL

IS67WVO8M8DALL/BLL

64Mb OctalRAM

**1.8V/3.0V SERIAL PSRAM MEMORY WITH 200MHZ DTR OPI
(OCTAL PERIPHERAL INTERFACE) PROTOCOL**

DATA SHEET

64Mb OctalRAM

SERIAL PSRAM MEMORY WITH 200MHz DTR OPI (Octal Peripheral Interface) Protocol

FEATURES

- **Industry Standard Serial Interface**

- Octal Peripheral Interface (OPI) Protocol
- Low Signal Counts :11 Signal pins (CS#, SCLK, DQSM, SIO0~SIO7)

- **High Performance**

- Up to 400MB/s
- Double Transfer Rate (DTR) Operation
- 200MHz (400MB/s) at 105°C
- 166MHz (332MB/s) at 125°C
- Source Synchronous Output signal during Read Operation (DQSM)
- Data Mask during Write Operation (DQSM)
- Configurable Latency for Read/Write Operation)
- Supports Variable Latency mode and Fixed Latency mode
- Configurable Drive Strength
- Supports Wrapped Burst mode and Continuous Burst mode
- Supports Deep Power Down mode
- Hidden Refresh

- **Burst Operation**

- Configurable Wrapped Burst Length : 16, 32, 64, and 128
- Word Order Burst Sequence
- Continuous Burst Operation:
 - Continues Read operation until the end of array address
 - Continues Write operation even after the end of array address

- **Low Power Consumption**

- Single 1.7V to 1.95V Voltage Supply
- Single 2.7V to 3.6V Voltage Supply
- 375 μ A Standby Current (typ.) at 105°C.

- **Hardware Features**

- **SCLK Input:** Serial clock input
- **SIO0 - SIO7:** Serial Data Input or Serial Data Output
- **DQSM:**
 - Output during command, address transactions as Refresh Collision Indicator
 - Output during read data transactions as Read Data Strobe
 - Input during write data transactions as Write Data Mask
- **RESET#:** Hardware Reset pin

- **Temperature Grades**

- Industrial: -40°C to +85°C
- Auto (A2) Grade: -40°C to +105°C
- Auto (A3) Grade: -40°C to +125°C

- **Industry Standard PACKAGE**

- B = 24-ball TFBGA 6x8mm 5x5 Array
- KGD (Call Factory)

GENERAL DESCRIPTION

The IS66/67WVO8M8DALL/BLL are integrated memory device containing 64Mb Pseudo Static Random Access Memory using a self-refresh DRAM array organized as 8M words by 8 bits.

The device supports Octal Peripheral Interface (Address, Command, and Data through 8 SIO pins), Very Low Signal Count (11 signal pins; SCLK, CS#, DQSM, and 8 SIOs), Hidden Refresh Operation, and Automotive temperature (A3, -40°C to +125°C) operation.

Due to DTR operation, minimum transferred data size is word (16 bits) base instead of byte (8 bits) base.

PERFORMANCE SUMMARY

Read / Write Operation	
Maximum Clock Rate at 1.8V VCC/VCCQ, 105°C	200MHz
Maximum Clock Rate at 3.0V VCC/VCCQ, 105°C	200MHz

Maximum Current Consumption		
VCC Active Read Current	3V	30 mA
	1.8V	30 mA
VCC Active Write Current	3V	25 mA
	1.8V	25 mA
Standby (CS# = High, 125°C)	3V	600 uA
	1.8V	600 uA
Deep Power Down (CS# = High, 125°C)	3V	50 uA
	1.8V	30 uA

TABLE OF CONTENTS

FEATURES	2
GENERAL DESCRIPTION	3
PERFORMANCE SUMMARY	3
TABLE OF CONTENTS	4
1. PIN CONFIGURATION.....	5
2. PIN DESCRIPTIONS.....	6
3. BLOCK DIAGRAM	7
4. COMMAND AND ADDRESS ASSIGNMENTS	8
5. Memory READ/WRITE OPERATIONS.....	9
5.1 Memory READ OPERATIONS	9
5.2 WRITE OPERATIONS.....	13
5.3 PREAMBLE BIT Data PATTERN READ OPERATION.....	16
5.4 RESET OPERATION.....	17
5.5 POWER-UP INITIALIZATION.....	18
6. REGISTER.....	19
6.1 REGISTER READ/WRITE OPERATION	19
6.2 CONFIGURATION REGISTER	20
6.3 DEVICE IDENTIFICATION REGISTER	25
7. ELECTRICAL CHARACTERISTICS.....	26
7.1 ABSOLUTE MAXIMUM RATINGS ⁽¹⁾	26
7.2 OPERATING RANGE	26
7.3 DC CHARACTERISTICS.....	27
7.4 AC Measurement Conditions.....	28
7.5 PIN CAPACITANCE (TA = 25°C, VCC=1.8V/ 3V, 1MHz).....	28
7.6 AC CHARACTERISTICS.....	29
8. PACKAGE TYPE INFORMATION.....	32
8.1 24-Ball Thin Profile Fine Pitch BGA 6x8mm 5x5 BALL ARRAY (B).....	32
9. ORDERING INFORMATION – Valid Part Numbers.....	33

1. PIN CONFIGURATION

24-ball TFBGA (5x5 ball array)

Top View, Balls Facing Down

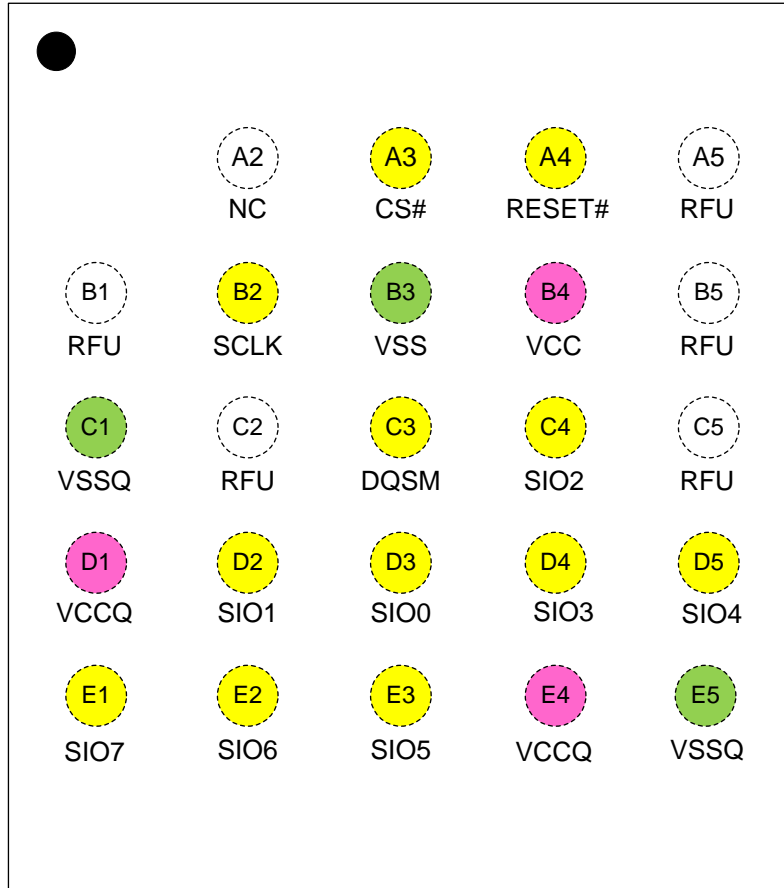

2. PIN DESCRIPTIONS

SYMBOL	TYPE	DESCRIPTION
CS#	INPUT	Chip Select: Bus transactions are initiated with a High to Low transition. Bus transactions are initiated with a Low to High transition.
DQSM	INPUT/OUTPUT	Refresh Collision Indicator ⁽²⁾, Data Strobe Signal in Read operation, and Write Data Mask in Write operation:
RESET# ⁽¹⁾	INPUT	RESET#: The RESET# pin is a hardware RESET signal. When RESET# is driven HIGH, the memory is in the normal operating mode. When RESET# is driven Low, the memory enters reset mode and output is High-Z.
SIO0-SIO7	INPUT	Serial Data Input & Output pins.
SCLK	INPUT	Serial Data Clock: Synchronized Clock for input and output timing operations.
VCC	POWER	Power Supply
VCCQ	POWER	IO Power Supply
VSS	GROUND	Ground
VSSQ	GROUND	IO Ground
RFU	Reserved	RFU: Reserved for future use: May or may not be connected internally.
NC	Unused	NC: No Connect: Not connected internally. The ball may be used in PCB routing.

Notes:

- RESET# pin has an internal pull-up.**
- Contact ISSI MKT for DQSM without Refresh Collision Indicator

3. BLOCK DIAGRAM

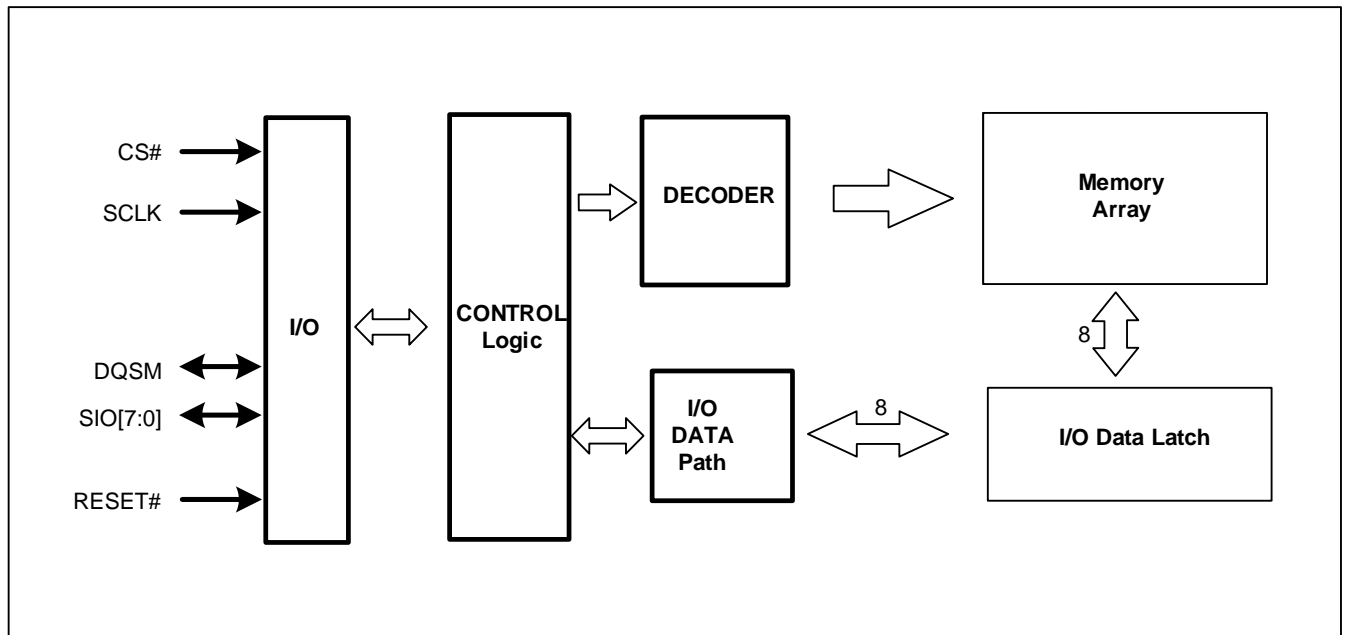

4. COMMAND AND ADDRESS ASSIGNMENTS

The device is serial interface, so all command and address inputs are transferred through SIO pins.

Figure 4.1 Command and Address Cycles

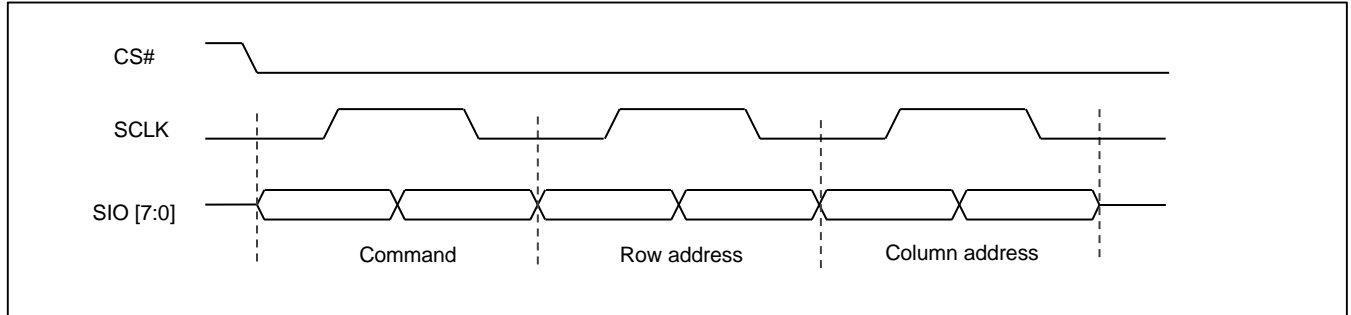

Notes:

1. The figure shows the initial three clock cycles of all operations on the OctalRAM Interface.
2. Command and Address information is “center aligned” with the clock during both Read and Write operations.

Table 4.1 Command / Address bit assignment

Clock	1 st clock	2 nd clock		3 rd clock	
Function	Command	Row address		Column address	
SIO[7]	Command	Reserved	RA7	CA9	Reserved
SIO[6]		Reserved	RA6	CA8	Reserved
SIO[5]		Reserved	RA5	CA7	Reserved
SIO[4]		RA12	RA4	CA6	Reserved
SIO[3]		RA11	RA3	CA5	CA3
SIO[2]		RA10	RA2	CA4	CA2
SIO[1]		RA9	RA1	Reserved	CA1
SIO[0]		RA8	RA0	Reserved	CA0 ⁽³⁾

Notes:

1. The 64Mb OctalRAM address assignments:
- Row Address 12 ~ 0: 8K (13bits), Column Address 9 ~ 0: 1k (10bits), 64Mb density = 8K X 1K X 8 (bits)
2. Data is always transferred in full word increment (word granularity -2 bytes-transfer).
3. Column Address A0 should be always 0.

Table 4.2 Command / Address bit assignment

Command	1 st clock		2 nd clock		3 rd clock	
	Command		Row address		Column address	
Memory READ with continuous burst	A0h	00h	RA[12:0]		CA[9:0]	
Memory READ with wrapped burst	80h	00h	RA[12:0]		CA[9:0]	
Memory WRITE with continuous burst	20h	00h	RA[12:0]		CA[9:0]	
Memory WRITE with wrapped burst	00h	00h	RA[12:0]		CA[9:0]	
Identification Register (read only)	C0h or E0h	00h	00h	00h	00h	00h
Configuration Register READ	C0h or E0h	00h	00h	04h	00h	00h
Configuration Register WRITE	40h or 60h	00h	00h	04h	00h	00h
Preamble Bit Pattern READ	F0h	00h	Don't care		CA[9:1] Don't care CA[0] Pattern Selection	

5. Memory READ/WRITE OPERATIONS

5.1 MEMORY READ OPERATIONS

Figure 5.1 Read Timing Diagram - No Refresh Collision at Variable Latency READ (1LC operation)

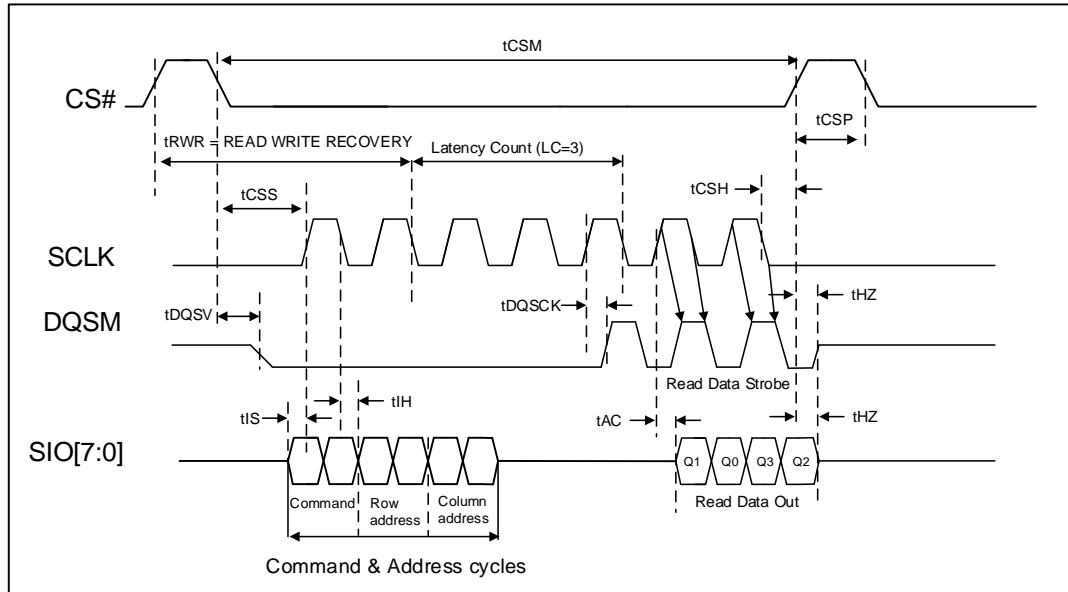

Notes:

1. The Latency count is defined by the initial latency value in a configuration register.
2. Latency count (LC) is 3 clocks, CR [8] = 1 (DQSM 1 clock pre-cycle before Valid READ Data).
3. Diagram in the figure above is representative of **variable latency with no refresh collision access**.
4. Read access (LC) starts once RA [7:0] is captured (falling edge of 2nd command/address clock)
5. The memory drives DQSM during read cycles.
6. DQSM is a read data strobe with data values edge aligned with the transitions of DQSM driven by the OctalRAM.
7. Column address A0 must be 0.

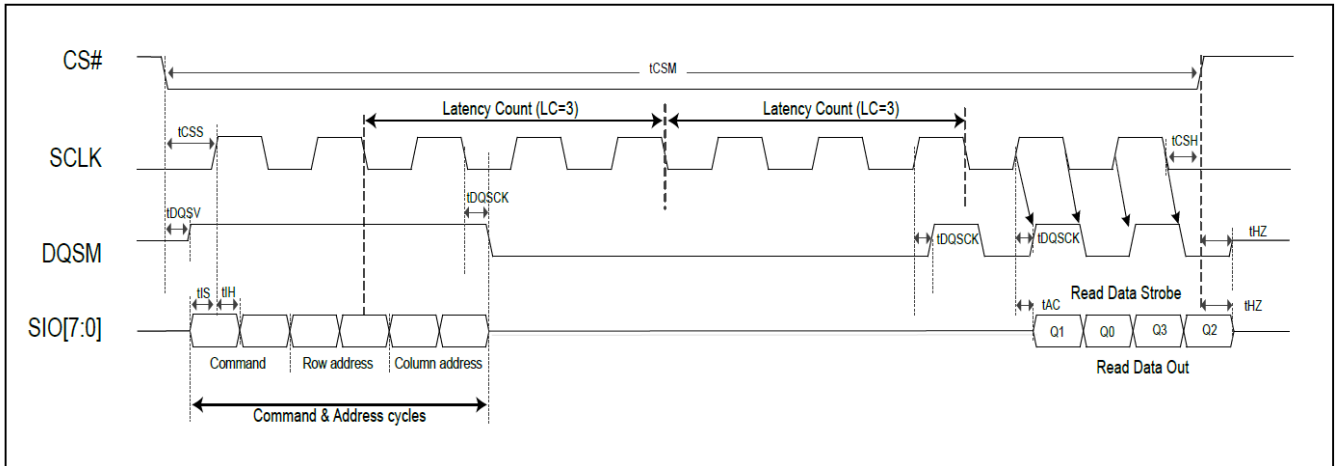
Figure 5.2 Read Timing Diagram - Refresh Collision at Variable-Latency READ (2LC operation)

Notes:

1. The Latency count is defined by the initial latency value in a configuration register.
2. Latency count (LC) is 3 clocks, CR [8] =1 (DQSM 1 clock pre-cycle before Valid READ Data).
3. Diagram in the figure above is representative of **variable latency with refresh collision or fixed-latency access (2LC operation)**.
4. In this Read there is a 2 Latency Count (2LC) for read access.
5. Read access (LC) starts once RA [7:0] is captured.
6. The memory drives DQSM during read cycles.
7. DQSM is a read data strobe with data values edge aligned with the transitions of DQSM driven by the OctalRAM.
8. Column address A0 must be 0.
9. **Fixed initial READ access latency outputs the first data at a consistent time regardless of worst-case refresh collisions.**

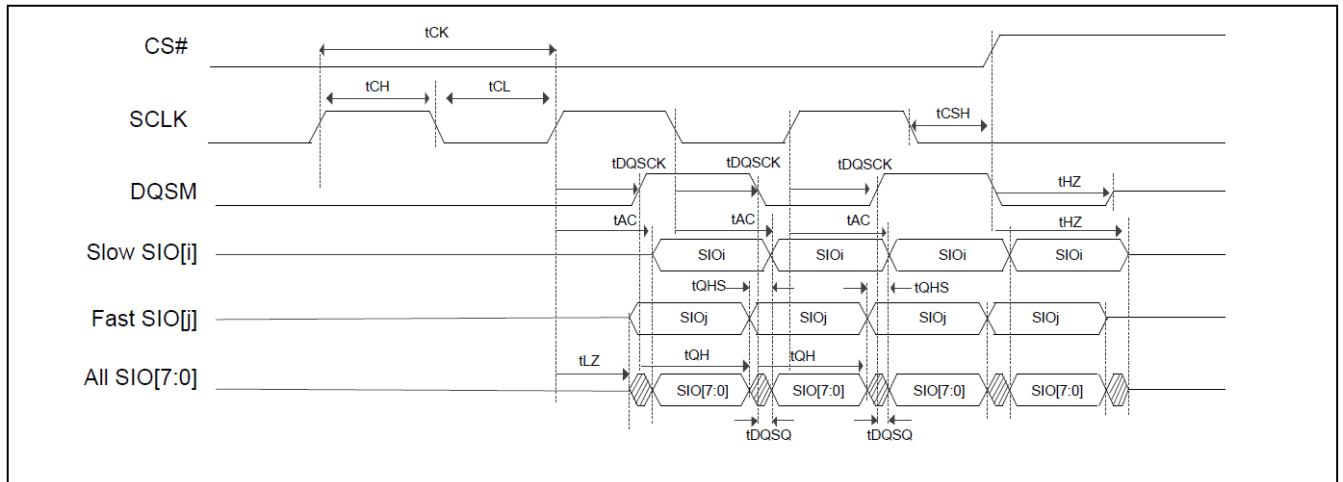
Figure 5.3 Data Valid Timing



Notes:

1. Burst READ data valid timing in detail.
2. t_{AC} defines CLK transition to DQ Valid.
3. t_{DQSK} defines CLK transition to DQSM Valid.
4. t_{DQSQ} defines DQSM-DQ skew.
5. t_{QHS} defines Data Hold skew factor.
6. t_{QH} defines DQ hold time from DQSM.

Figure 5.4 READ Burst Wrap

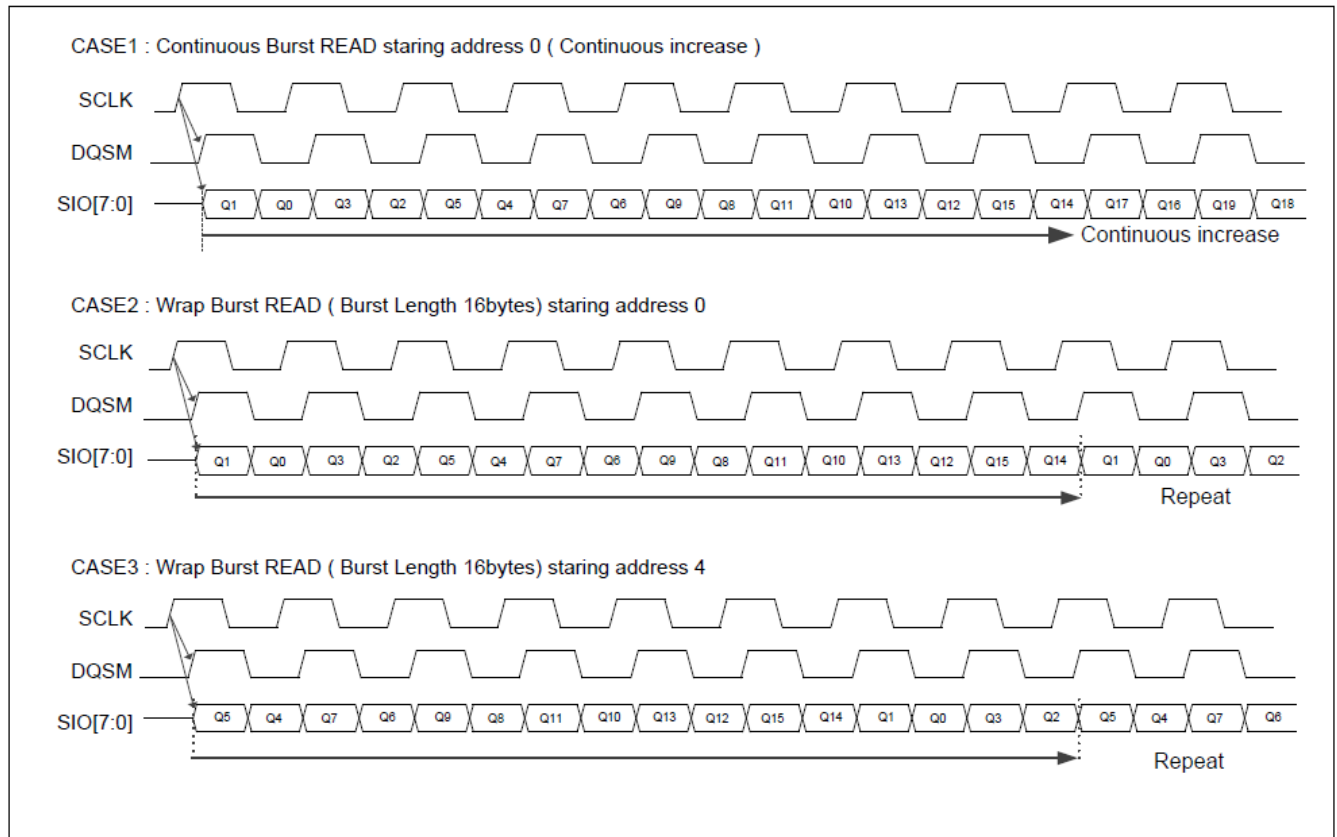

Notes:

1. CS# can stay Low between burst operations, but CS# must not remain Low longer than tCSM.
2. Read operation can be ended at any time by bringing CS# High.
3. Continues Read operation until last address. Continuing beyond last address, undefined data will be available.

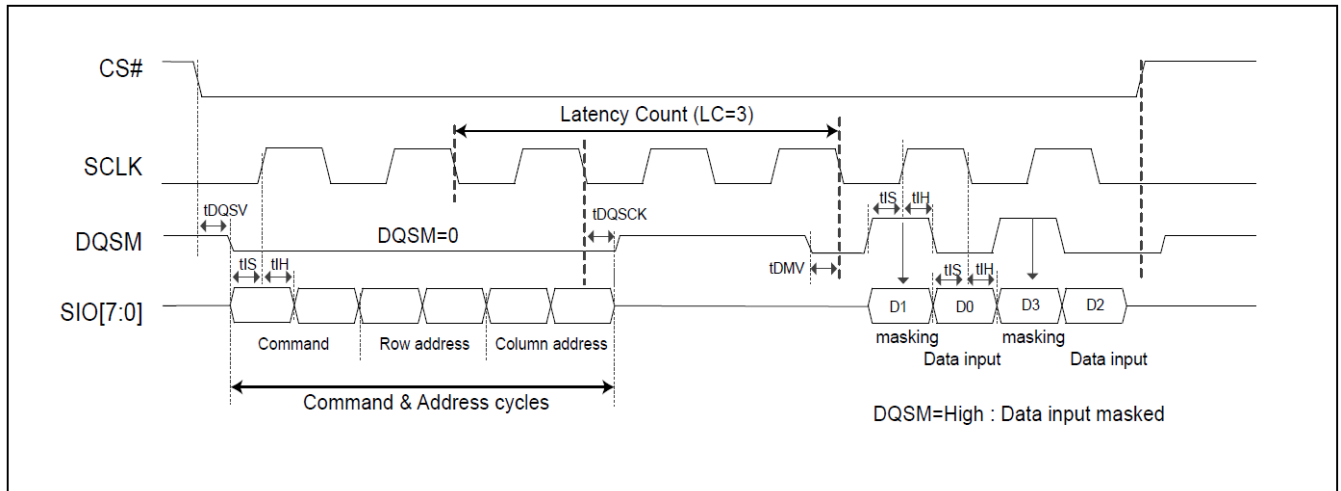
5.2 WRITE OPERATIONS
Figure 5.5 No Refresh Collision at Variable Latency WRITE (1LC) / Data Input Masking

Notes:

1. The Latency count is defined by the initial latency value in a configuration register.
2. Latency count (LC) is 3 clocks.
3. Diagram in the figure above is representative of **variable latency with no refresh collision access**.
4. Write access (LC) starts once RA [7:0] is captured.
5. The memory drives DQSM "Low" during command address cycles and DQSM goes to "Hi-Z" after command address cycles.
6. The system memory controller must drive DQSM to a valid Low before the end of initial latency to provide a data mask preamble time.
This can be done during the last cycle of LC cycle.
7. During Write data input, data is center aligned with the clock.
8. During Write data input, DQSM indicates whether each data byte is masked with DQSM High or not masked with DQSM Low.
9. D1, D3 are masked.
10. Column address A0 must be 0.

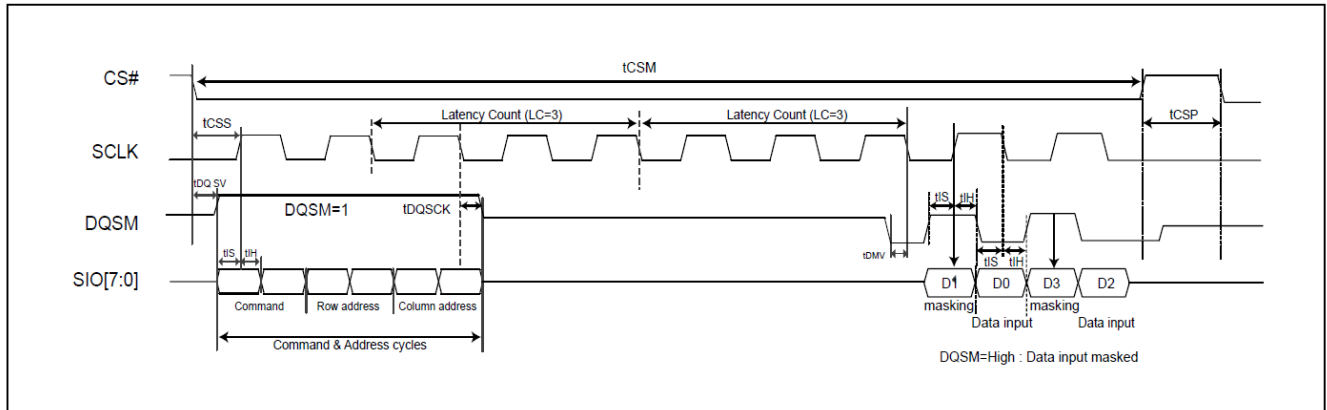
Figure 5.6 Refresh Collision at Variable Latency WRITE (2LC) / Data Input Masking



Notes:

1. The Latency count is defined by the initial latency value in a configuration register.
2. Latency count (LC) is 3 clocks.
3. Diagram in the figure above is representative of **variable latency with refresh collision or fixed-latency access. (2LC operation)**
4. **In this Write there is a latency count (2LC) for WRITE operation**
5. Write access (LC) starts once RA [7:0] is captured.
6. The memory drives DQSM High during command address cycles and DQSM goes to "Hi-Z" after command address cycles.
7. The system memory controller must drive DQSM to a valid Low before the end of initial latency to provide a data mask preamble time.
This can be done during the last cycle of LC cycle.
8. During Write data input, data is center aligned with the clock.
9. During Write data input, DQSM indicates whether each data byte is masked with DQSM High or not masked with DQSM Low.
10. D1, D3 are masked.
11. Column address A0 must be 0.

Figure 5.7 WRITE Burst Wrap

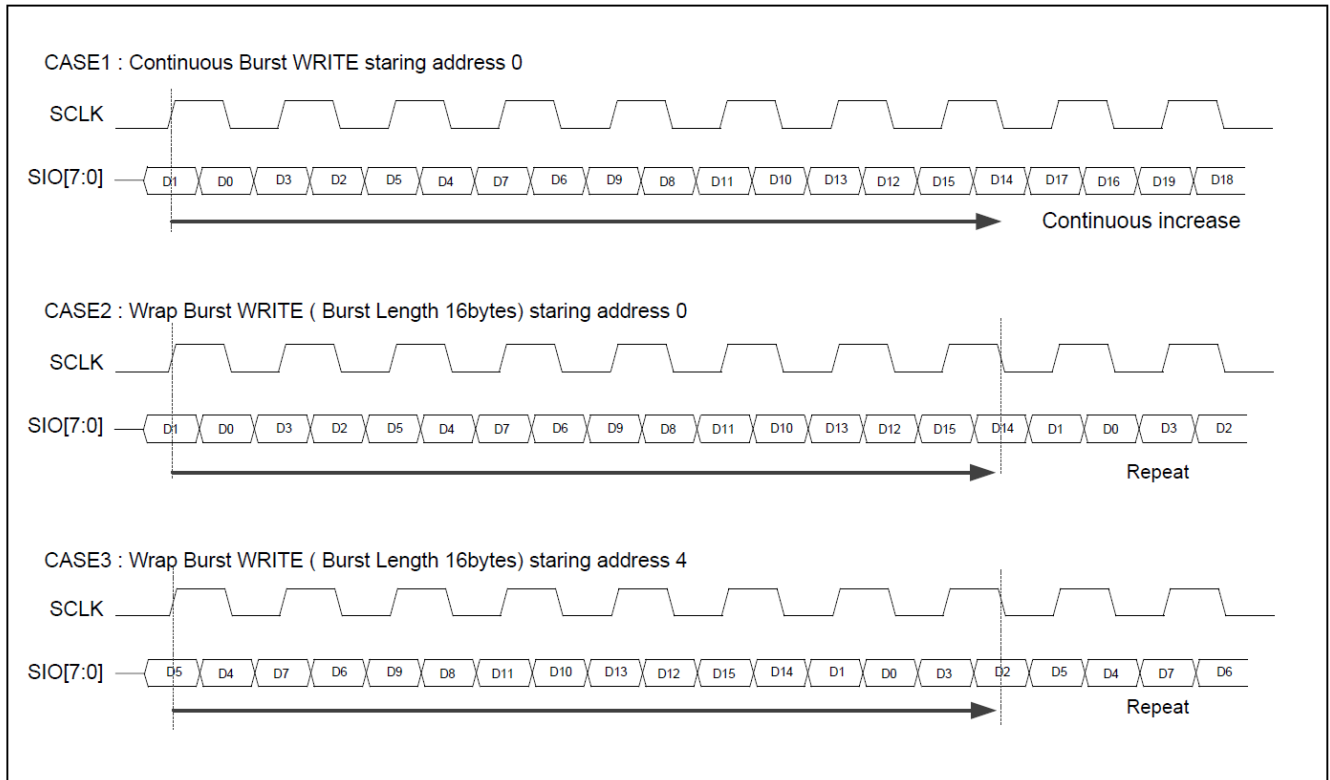

Notes:

1. CS# can stay Low between burst operations, but CS# must not remain Low longer than tCSM.
2. Write operation can be ended at any time by bringing CS# High.
3. When continuous burst write reaches the last address in the memory array, continuing the burst will write to the beginning of the address.

5.3 PREAMBLE BIT DATA PATTERN READ OPERATION

The Preamble Bit Data Pattern READ Operation can improve data capture reliability while the OctalRAM is running in high frequency, while supporting the System/Memory Controller to determine the data output valid windows more easily.

The Preamble Bit is designed as a 16-bits data pattern, it can be output by Preamble Bit READ Command (F0h + 00h). The Row Address and Column Address are “don’t care”, except Column Address A0 is used for selecting the pattern.

Once Preamble Bit feature is enabled, a fixed 16-bits data pattern will output on all SIO pins, according to A0 setting in Column Address. Refer to "Table 5.1. Preamble Bit Data Pattern SIO assignments".

The Latency Count values are defined in configuration register CR [7-4] which is the same as Read timing diagram -1LC operation case.

Figure 5.8 Preamble Bit Data Pattern READ Timing, No Refresh Collision at Variable Latency

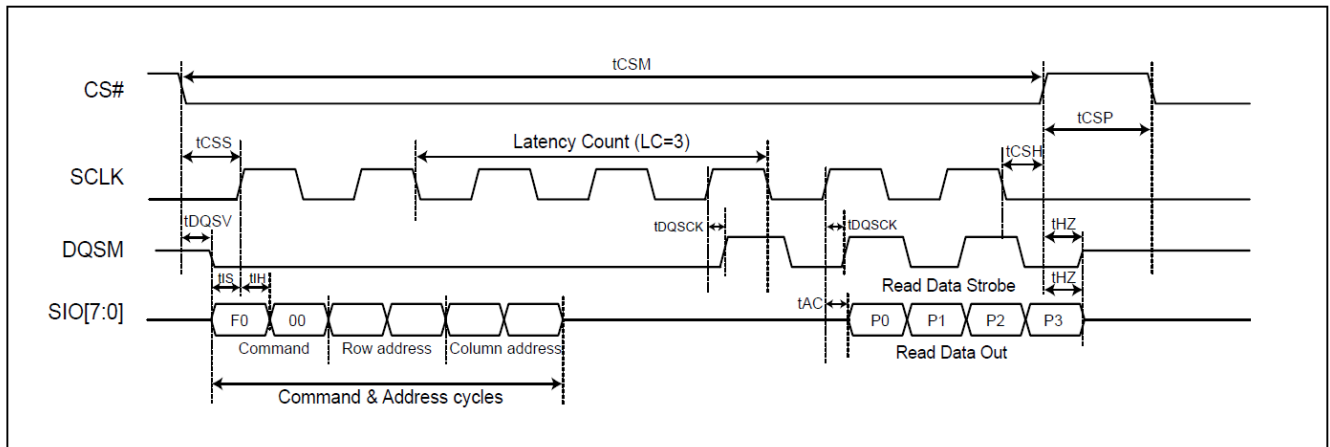

Notes:

1. Latency Count (LC) = 3 clocks, CR[8]=1 (DQSM 1 clock pre-cycle before Valid READ Data)
2. The memory drives DQSM during the entire Data Learning Pattern Read.
3. The required latency count is device and clock frequency dependent.
4. Column address A0 is used for pattern selection, and Row address RA [13:0] and Column address CA [9:1] are don't care.

Table 5.1 Preamble Bit Data Pattern SIO assignments

Column Address A0	All SIOs (except SIO3)	SIO3
A0=0	0011 0100 1001 1010	0011 0101 0001 0100
A0=1	0101 0101 0101 0101	0101 0101 0101 0101

5.4 RESET OPERATION

Figure 5.9 RESET Timing

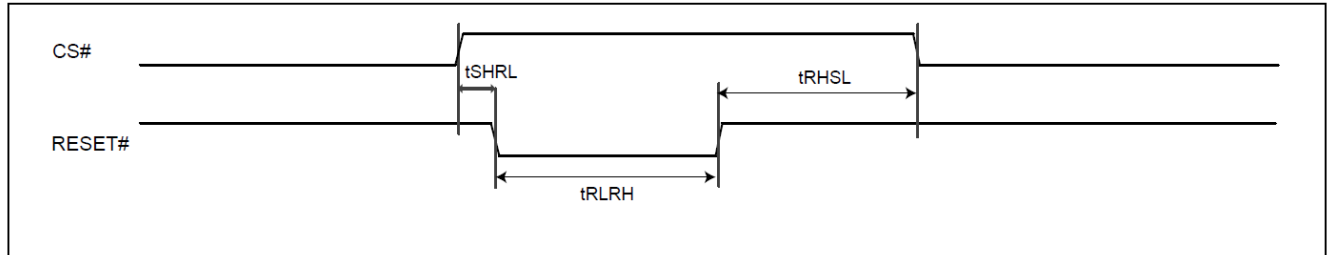
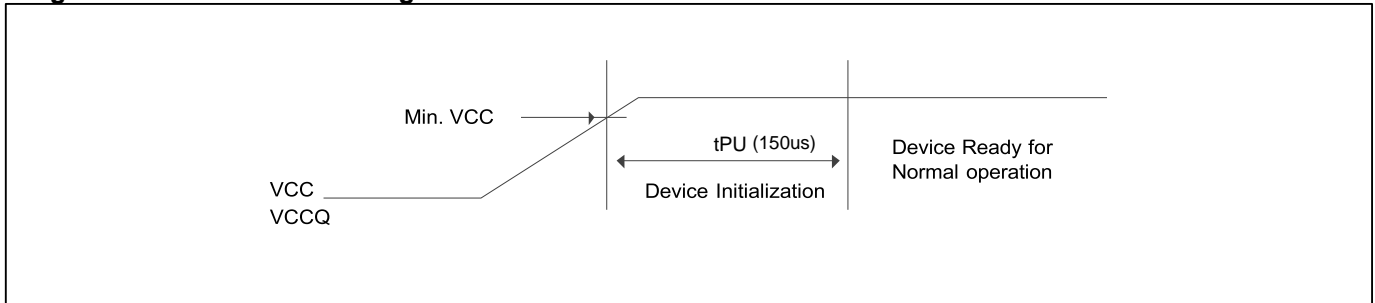

Table 5.2 RESET Timing Parameters

Parameter	Description	Min	Max	Unit
t_{SHRL}	RESET# Low after CS# High	15	-	ns
t_{RLRH}	RESET# Low Pulse width	10	-	us
t_{RHSL}	RESET# High before CS# Low	10	-	us

5.5 POWER-UP INITIALIZATION

Figure 5.10 POWER-UP Timing



6. REGISTER

The device has 16 bit Configuration Register and ID Register, and they can be accessed by Register Read or Write command.

6.1 REGISTER READ/WRITE OPERATION

Figure 6.1 Register WRITE, No Refresh Collision at Variable Latency

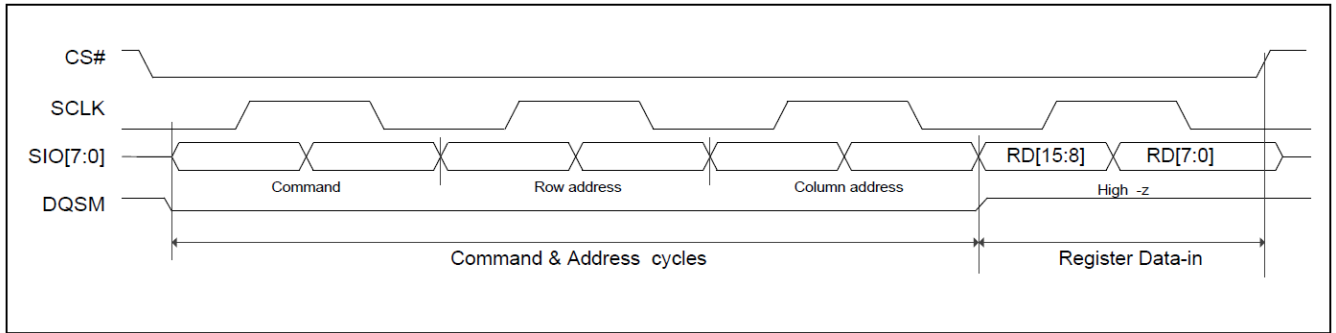

Notes:

1. The device drives DQSM “Low or High for Refresh indication” during command address cycles, which must be ignored by host. DQSM goes to “Hi-Z” after command address cycles.
2. The register value is always provided immediately after the Command Address cycles (0 cycle latency)
3. The DQSM signal keep Hi-Z during register data-in cycles. DQSM will be ignored by host and device during entire register write operation.

Figure 6.2 Register READ (Initial Latency = 1LC), No Refresh Collision at Variable Latency

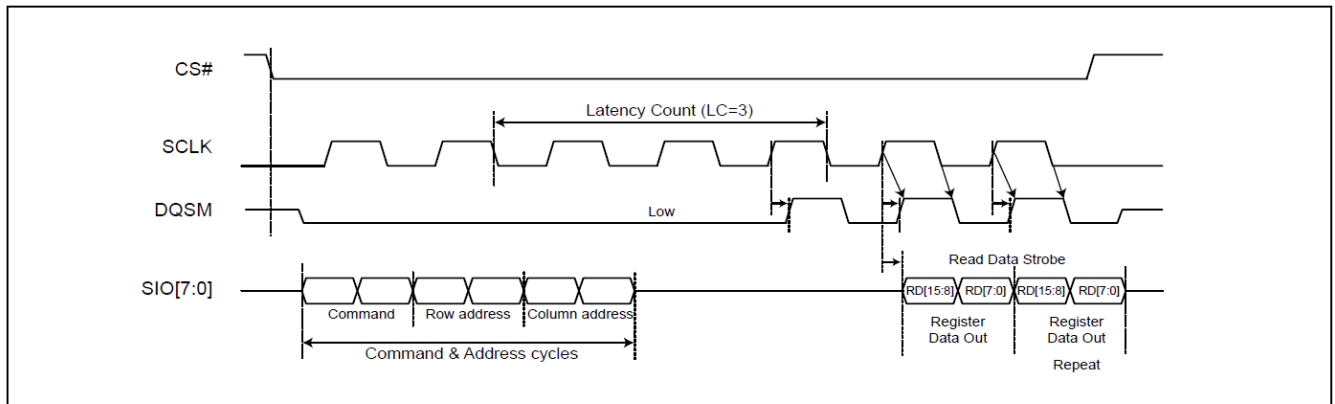

Notes:

1. The device drives DQSM “Low or High for Refresh indication” during command address cycles, which must be ignored by host. DQSM goes to “Low” after command address cycles until DQSM pre-cycle.
2. Initial Latency is 1LC for Register Read operation when DQSM is Low during command & address cycle. Refresh Indication. Initial Latency is always 2LC for Register Read operation when fixed initial latency is selected by configuration register.
3. DQSM is a read data strobe with register values edge aligned with the transitions of DQSM driven by the device.

6.2 CONFIGURATION REGISTER

The Configuration Register is able to change the defaulted status of the device. The device will be configured after the CR bit is set.

Table 6.1 Configuration Register

Bit	Function	Settings (Binary)
15	Deep Power Down Enable	1- Normal operation (default) 0- Writing 0 to CR [15] causes the device to enter Deep Power Down.
14-12	ODS (Output Drive Strength)	Refer to " Table 6.2. Output Driver Strength Table "
11-9	Reserved	Set to 000b
8	DQSM READ Pre-cycle	1 - 1 clock 0 - 0 clock (default)
7-4	Latency counter	Refer to " Table 6.3. Latency counter Table "
3	Initial Access Latency	0 - Variable Latency (default) 1 - Fixed Latency
2	Reserved	Set to 0b
1-0	Burst Length	00- 128 bytes 01- 64 bytes 10- 32 bytes (default) 11- 16 bytes

Table 6.2 Output Driver Strength Table

ODS2	ODS1	ODS0	Description
0	0	0	146 Ohms
0	0	1	76 Ohms
0	1	0	52 Ohms
0	1	1	41 Ohms
1	0	0	34 Ohms
1	0	1	30 Ohms
1	1	0	26 Ohms
1	1	1	24 Ohms (Default)

Table 6.3 Latency counter Table

CR[7:4]	Latency Counter
0000	3 clocks
0001	4 clocks
0010	5 clocks (default at 3V)
0011	6 clocks
0100	7 clocks
0101	8 clocks(default at 1.8V)
0110~1111	Reserved

6.2.1 WRAPPED BURST LENGTH
Table 6.4 Wrapped Burst Sequences

Command	Configuration Register[1:0]	Burst Type	Wrap Boundary Col. Addr	Start Address (Hex)	Address Sequence (Hex) : Bytes
Read	00	Wrap 128	CA[6:0]	XXXXXX06	07. 06, 09, 08,..... 7F, 7E, 01, 00, 03, 02, 05, 04, 07, 06, ...
Write	00	Wrap 128	CA[6:0]	XXXXXX06	07. 06, 09, 08,..... 7F, 7E, 01, 00, 03, 02, 05, 04, 07, 06, ...
Read	01	Wrap 64	CA[5:0]	XXXXXX02	03. 02, 05, 04, 07, 06,..... 3D, 3C, 3F, 3E, 01, 00, 03, 02, ...
Write	01	Wrap 64	CA[5:0]	XXXXXX02	03. 02, 05, 04, 07, 06,..... 3D, 3C, 3F, 3E, 01, 00, 03, 02, ...
Read	10	Wrap 32	CA[4:0]	XXXXXX1A	1B. 1A, 1D, 1C, 1F, 1E,..... 17, 16, 19, 18, 1B, 1A, 1C, 1B, ...
Write	10	Wrap 32	CA[4:0]	XXXXXX1A	1B. 1A, 1D, 1C, 1F, 1E,..... 17, 16, 19, 18, 1B, 1A, 1C, 1B, ...
Read	11	Wrap 16	CA[3:0]	XXXXXX0A	0B. 0A, 0D, 0C, 0F, 0E, 01, 00,..... 07, 06, 09, 08, 0B, 0A, ...
Write	11	Wrap 16	CA[3:0]	XXXXXX0A	0B. 0A, 0D, 0C, 0F, 0E, 01, 00,..... 07, 06, 09, 08, 0B, 0A, ...
Read	XX	Continuous	X	XXXXXX0C	0D, 0C, 0F, 0E, 11, 10, 13, 12, 15, 14, 17, 16, 19. 18, ...
Write	XX	Continuous	X	XXXXXX0C	0D, 0C, 0F, 0E, 11, 10, 13, 12, 15, 14, 17, 16, 19. 18, ...

Notes: When Continuous burst type is operated on burst operations, Memory access address will increase continuously regardless of Burst Wrap Length code.

6.2.2 INITIAL LATENCY (CR [3])

Initial Latency for Variable Latency setting (CR [3]=0) is LC or 2LC , based on Refresh Collision like below table. So host chipset must monitor DQSM signal, which indicates Refresh Collision occurrence or not. But Initial Latency for Fixed Latency setting (CR [3] = 1) is always 2LC.

Table 6.5 Variable Latency (CR[3] = 0)

Latency code CR[7:4]	Initial Latency Counter		Maximum Operating Frequency (MHz)			
	No Refresh Collision (LC)	Refresh Collision (2LC)	1.8V		3.0V	
			105°C	125°C	105°C	125°C
0000	3 clocks	6 clocks	83		83	
0001	4 clocks	8 clocks	100		100	
0010	5 clocks (default at 3V)	10 clocks	166	133	133	133
0011	6 clocks	12 clocks	166	133	166	133
0100	7 clocks	14 clocks	200	166	200	166
0101	8 clocks(default at 1.8V)	16 clocks	200	166	200	166
0100 - 1111	Reserved	-	NA			

Note:

1. Default setting for 1.8V device is “0101”, and that for 3.0V device is “0010”.

Table 6.6 Initial Latency Summary Table

Destination	Operating mode	Variable mode (default) initial Latency Count		Fixed mode Initial Latency Count
		No Refresh Collision	Refresh Collision	
Memory	READ	1LC	2LC	2LC
	WRITE	1LC	2LC⁽²⁾	2LC⁽²⁾
Register	READ	1LC	2LC⁽²⁾	2LC⁽²⁾
	WRITE	0LC		0LC

Notes:

1. LC means Latency Counter clocks, which is in Configuration Register Bit [7:4], as defined in "[Table 6.1](#)" and "[Table 6.3](#)".
2. Contact ISSI MKT if 1LC is required instead of 2LC.

6.2.3 DQSM READ Pre-Cycle (CR [8])

CR [8] defines DQSM Pre-Cycle.

Figure 6.3 DQSM pre-cycle during Burst READ

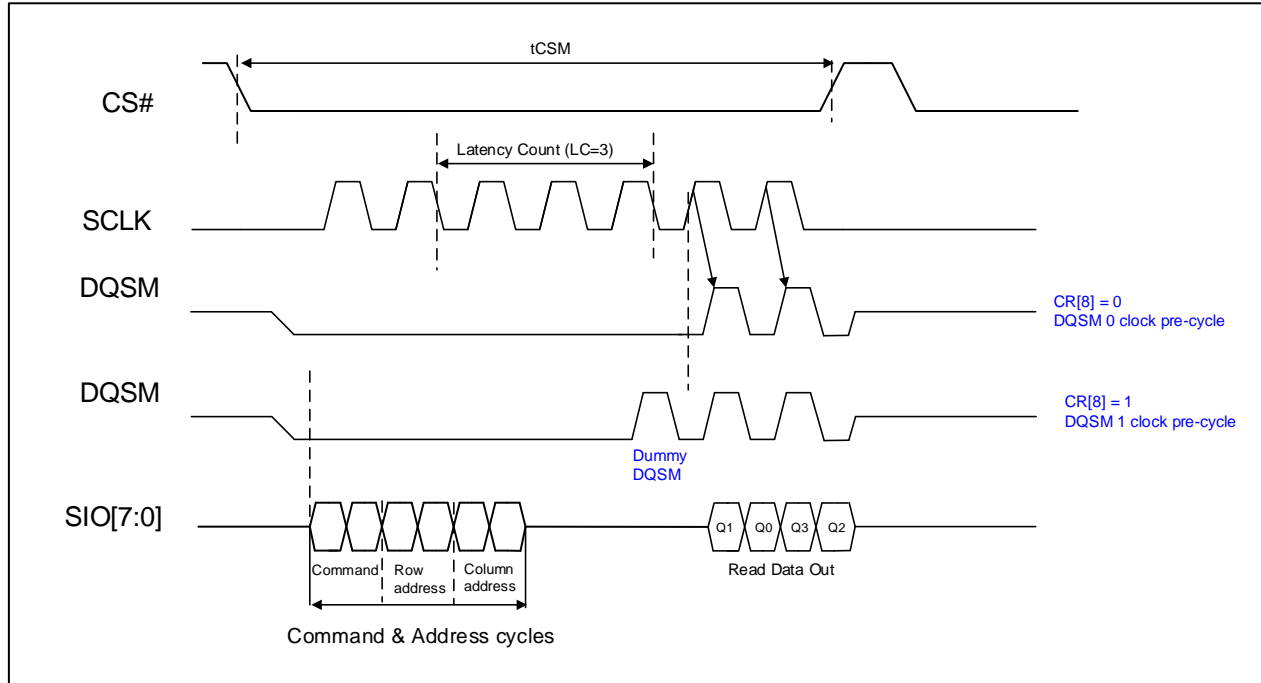

Notes:

1. Latency count (LC) is 3 clocks.
2. When Configuration Register bit8 = 0, the Device will output DQSM with valid data cycle.
3. When Configuration Register bit8 = 1, the Device will output **dummy DQSM** one clock cycle period prior to valid data cycle.
4. The memory drives DQSM during read data out cycles.

6.2.4 Deep Power Down (CR [15])

Figure 6.4 Deep Power Down Entry Timing

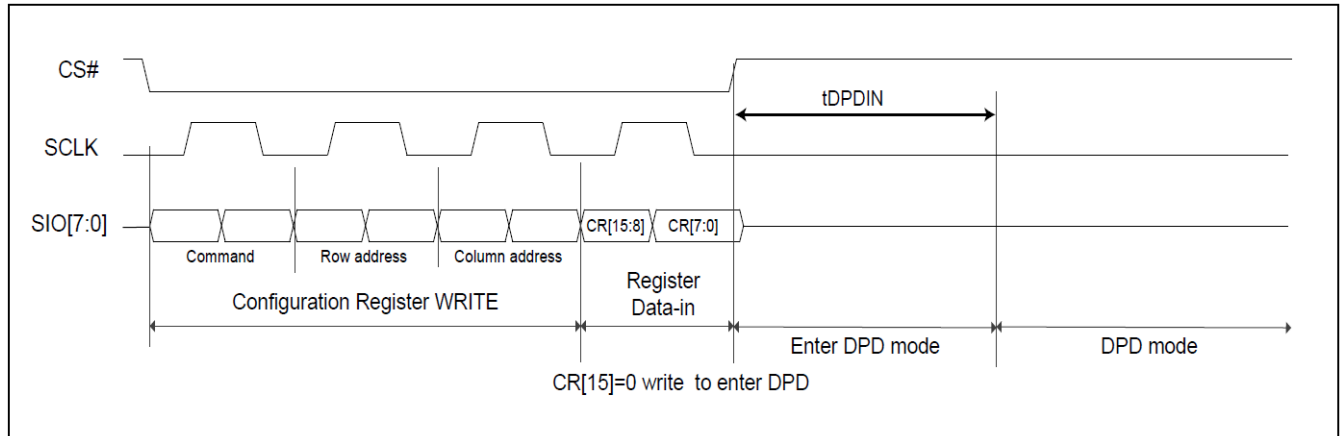
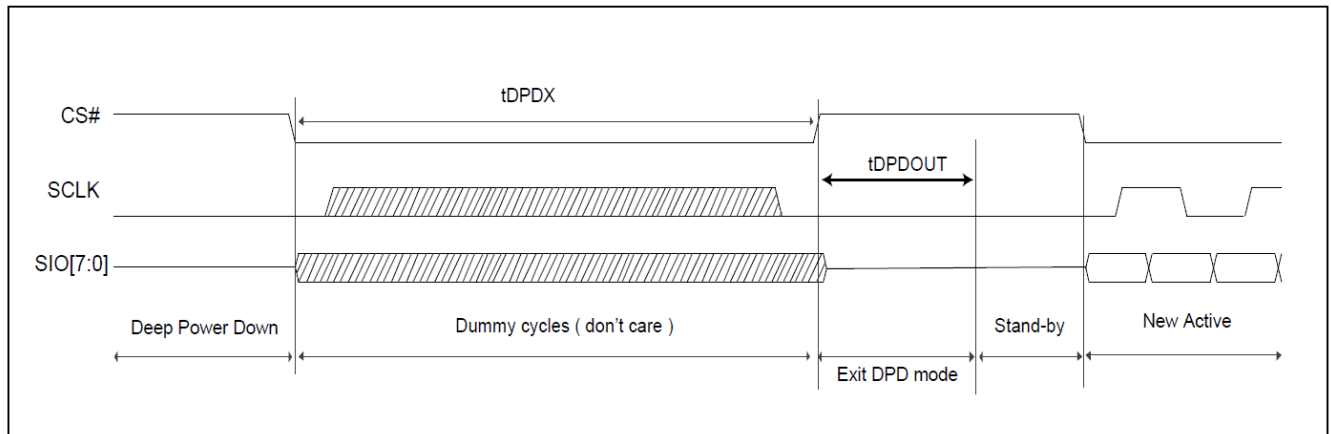

Figure 6.4 Deep Power Down Exit Timing



Notes: Memory Cell Data cannot be retained at deep power down(DPD) mode.

Table 6.7 Deep Power Down Timing Parameters

Parameter	Description	Min	Max	Unit
tDPDIN	Deep Power Down CR[15]=0 register write to DPD power level	150	-	us
tDPDX	CS# Low period to exit from Deep Power Down	200	-	ns
tDPDOUT	CS# Low then High to Standby wakeup time	-	150	us

6.3 DEVICE IDENTIFICATION REGISTER

It is a read only, non-volatile, word register that provides device information The device information fields can be identified as below.

- a. Device Type
- b. Density
 - i. Row address bit count
 - ii. Column address bit count
- c. Manufacturer

Table 6.8 ID Register

Bits	Function	Settings (Binary)
15 - 13	Device Voltage	000: 1.8V 001: 3V
12 - 8	Row address bit count	00000 : 1 row address 01100: 13 row address 11111 : 32 row address
7 - 4	Column address bit count	0000 : 1 column address 1001: 10 column address 1111 : 16 column address
3 - 0	Manufacturer	0011 (ISSI)

7. ELECTRICAL CHARACTERISTICS

7.1 ABSOLUTE MAXIMUM RATINGS ⁽¹⁾

Storage Temperature	-65°C to +150°C
Input Voltage with Respect to Ground on All Pins	-0.5V to V _{CC} + 0.5V
All Output Voltage with Respect to Ground	-0.5V to V _{CC} + 0.5V
V _{CC}	-0.5V to +4.0V
Electrostatic Discharge Voltage (Human Body Model) ⁽²⁾	-2000V to +2000V

Notes:

1. Applied conditions greater than those listed in “Absolute Maximum Ratings” may cause permanent damage to the device. This is a stress rating only and functional operation of the device at these or any other conditions above those indicated in the operational sections of this specification is not implied. Exposure to absolute maximum rating conditions for extended periods may affect reliability.
2. ANSI/ESDA/JEDEC JS-001

7.2 OPERATING RANGE

Operating Temperature	Industrial	-40°C to 85°C
	Automotive Grade A2	-40°C to 105°C
	Automotive Grade A3	-40°C to 125°C
V _{CC} Power Supply	IS66/67WVO8M8DALL	1.70V (V _{MIN}) –1.95V (V _{MAX}); 1.8V (Typ)
	IS66/67WVO8M8DBLL	2.7V (V _{MIN}) –3.6V (V _{MAX}); 3.0V (Typ)

7.3 DC CHARACTERISTICS

Symbol	Parameter	Min.	Typ.	Max.	Units	Test Conditions
I _{LI}	Input Leakage Current 3V Device Reset Signal Only	-	-	±10.0	uA	V _{IN} = V _{SS} to V _{CC} , V _{CC} = V _{CC} max
I _{LI}	Input Leakage Current 1.8V Device Reset Signal Only	-	-	±5.0	uA	V _{IN} = V _{SS} to V _{CC} , V _{CC} = V _{CC} max
I _{CC1}	VCC Active Read Current	-	25	30	mA	CS# = V _{IL} , @200MHz, V _{CC} = 1.9V
			25	30		CS# = V _{IL} , @100MHz, V _{CC} = 3.6V
I _{CC2}	VCC Active Write Current	-	20	25	mA	CS# = V _{IL} , @200MHz, V _{CC} = 1.9V
			20	25		CS# = V _{IL} , @100MHz, V _{CC} = 3.6V
I _{CC4I}	VCC Standby Current for Industrial (-40°C to +85°C)	-	375	400	uA	CS#, V _{CC} =V _{CC} max
I _{CC4IP}	VCC Standby Current for Extended (-40°C to +105°C)	-	375	600		
I _{CC4EP}	VCC Standby Current for Extended Plus (-40°C to +125°C)	-	375	600		
I _{CC5}	Reset Current	-	5	10	mA	CS# = V _{IH} , RESET# = V _{SS} +/- 0.3V, V _{CC} = V _{CC} max
I _{CC6I}	Active Clock Stop Current for Industrial (-40°C to +85°C)	-	5	10	mA	CS# = V _{IL} , RESET# = V _{CC} +/- 0.3V, V _{CC} = V _{CC} max
I _{CC6IP}	Active Clock Stop Current for Extended (-40°C to +105°C)	-	5	10		
I _{CC6EP}	Active Clock Stop Current for Extended Plus (-40°C to +125°C)	-	5	10		
I _{CC7}	VCC Current during power up	-	-	40	mA	CS#, = H, V _{CC} = V _{CC} max, V _{CC} =V _{CCQ} = 1.95V or 3.6V
I _{DPDI}	Deep Power Down Current 3V for Industrial (-40°C to +85°C)	-	-	30	uA	CS#, V _{CC} = 3.6V
	Deep Power Down Current 1.8V for Industrial (-40°C to +85°C)	-	-	20		CS#, V _{CC} = 1.9V
I _{DPDIP}	Deep Power Down Current 3V for Extended (-40°C to +105°C)	-	-	50		CS#, V _{CC} = 3.6V
	Deep Power Down Current 1.8V for Extended (-40°C to +105°C)	-	-	30		CS#, V _{CC} = 1.9V
I _{DPDEP}	Deep Power Down Current 3V for Extended (-40°C to +125°C)	-	-	50		CS#, V _{CC} = 3.6V
	Deep Power Down Current 1.8V for Extended (-40°C to +125°C)	-	-	30		CS#, V _{CC} = 1.9V
V _{IL} ⁽¹⁾	Input Low Voltage	-0.5		0.3V _{CC}	V	
V _{IH} ⁽¹⁾	Input High Voltage		0.7V _{CC}	V _{CC} + 0.3	V	
V _{OL}	Output Low Voltage			0.2	V	I _{OL} = 100 μA
V _{OH}	Output High Voltage	V _{CC} - 0.2			V	I _{OH} = -100 μA

Notes:

- Maximum DC voltage on input or I/O pins is V_{CC} + 0.5V. During voltage transitions, input or I/O pins may overshoot V_{CC} by +2.0V for a period of time not to exceed 20ns. Minimum DC voltage on input or I/O pins is -0.5V. During voltage transitions, input or I/O pins may undershoot GND by -2.0V for a period of time not to exceed 20ns.
- Typical values are included for reference only and are not guaranteed or tested. Typical values are measured at V_{CC} = V_{CC} (Typ), TA=25°C.

7.4 AC MEASUREMENT CONDITIONS

Symbol	Parameter	Min	Max	Units
CL	Output Load Capacitance		20	pF
TR,TF	Input Rise and Fall Times	2		V/ns
VIN	Input Pulse Voltages	0V to V _{CCQ}		V
VREFI	Input Timing Reference Voltages	V _{CCQ} /2		V
VREFO	Output Timing Reference Voltages	V _{CCQ} /2		V

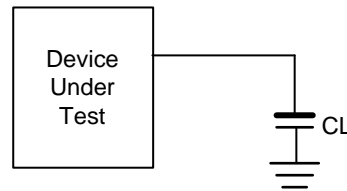
Figure 7.1 Test Setup

7.5 PIN CAPACITANCE (TA = 25°C, VCC=1.8V/ 3V, 1MHZ)

Symbol	Parameter	Test Condition	Min	Typ	Max	Units
C _{IN}	Input Capacitance (CS#, SCLK)	V _{IN} = 0V	3	-	4.5	pF
C _{IN/OUT}	Input/Output Capacitance (SIO, DQSM)	V _{IN/OUT} = 0V	3	-	4.0	pF

Note:

1. These parameters are characterized and not 100% tested.

7.6 AC CHARACTERISTICS
7.6.1 Read Timing Parameters (1.8V)

Symbol	Parameter	200MHz		166MHz		Unit
		Min.	Max.	Min.	Max.	
LC	Latency Counter (No Refresh Collision)	7 ⁽¹⁾	-	5 ⁽¹⁾	-	clock
tRWR	Read-Write Recovery Time	35 ⁽¹⁾	-	30 ⁽¹⁾	-	ns
tCK	Clock(CLK) Period	5	-	6	-	ns
tCH	Clock High level width	0.45	-	0.45	-	tCKmi
tCL	Clock Low level width	0.45	-	0.45	-	tCKmi
tHP	Clock half period	Min(tCH,tCL)	-	Min(tCH,tCL)	-	ns
tDQSV	CS# Active to DQSM valid	-	12	-	12	ns
tAC	Clock transition to DQ valid	0.9	5	1	5.5	ns
tDQSCK	Clock transition to DQSM valid	0.9	5	1	5.5	ns
tCSP	CS# High Between READ/WRITE	6	-	6	-	ns
tCSS	CS# Setup to next CLK Rising Edge	3	-	3	-	ns
tCSH	CS# Hold After CLK Falling Edge	2	-	2	-	ns
tIS	Input Setup	0.5	-	0.6	-	ns
tIH	Input Hold	0.5	-	0.6	-	ns
tDQSQ	DQSM-DQ Skew	-	0.4	-	0.45	ns
tQHS	Data Hold Skew factor	-	0.8	-	0.85	ns
tQH	DQ hold time from DQSM	tHP-tQHS	-	tHP-tQHS	-	ns
tLZ	Clock to DQ Low-Z	0	-	0	-	ns
tHZ	CS# Inactive to DQSM and DQ High-Z	-	5	-	6	ns
tCSM	Chip Select Maximum Low Time (~ 85°C)	-	4.0	-	4.0	us
tCSM	Chip Select Maximum Low Time (~ 125°C)	-	1.0	-	1.0	us

Note:

1. Ambient temperature is up to 105°C.

7.6.2 Read Timing Parameters (3.0V)

Symbol	Parameter	200MHz		166MHz		Unit
		Min.	Max.	Min.	Max.	
LC	Latency Counter (No Refresh Collision)	7 ⁽¹⁾	-	6 ⁽¹⁾	-	clock
tRWR	Read-Write Recovery Time	35 ⁽¹⁾	-	36 ⁽¹⁾	-	ns
tCK	Clock(CLK) Period	5	-	6	-	ns
tCH	Clock High level width	0.45	-	0.45	-	tCKmi
tCL	Clock Low level width	0.45	-	0.45	-	tCKmi
tHP	Clock half period	Min(tCH,tCL)	-	Min(tCH,tCL)	-	ns
tDQSV	CS# Active to DQSM valid	-	12	-	12	ns
tAC	Clock transition to DQ valid	0.9	6.0	1	6.5	ns
tDQSCK	Clock transition to DQSM valid	0.9	6.0	1	6.5	ns
tCSP	CS# High Between READ/WRITE	6	-	6	-	ns
tCSS	CS# Setup to next CLK Rising Edge	3	-	3	-	ns
tCSH	CS# Hold After CLK Falling Edge	2	-	2	-	ns
tIS	Input Setup	0.5	-	0.6	-	ns
tIH	Input Hold	0.5	-	0.6	-	ns
tDQSQ	DQSM-DQ Skew	-	0.4	-	0.7	ns
tQHS	Data Hold Skew factor	-	0.8	-	0.85	ns
tQH	DQ hold time from DQSM	tHP-tQHS	-	tHP-tQHS	-	ns
tLZ	Clock to DQ Low-Z	0	-	0	-	ns
tHZ	CS# Inactive to DQSM and DQ High-Z	-	5	-	6	ns
tCSM	Chip Select Maximum Low Time (~ 85°C)	-	4.0	-	4.0	us
tCSM	Chip Select Maximum Low Time (~ 125°C)	-	1.0	-	1.0	us

Note:

1. Ambient temperature is up to 105°C.

7.6.3 WRITE Timing Parameters (1.8V)

Symbol	Parameter	200MHz		166MHz		Unit
		Min.	Max.	Min.	Max.	
LC	Latency Counter (No Refresh Collision)	7 ⁽¹⁾	-	5 ⁽¹⁾	-	clock
tRWR	Read-Write Recovery Time	35 ⁽¹⁾	-	30 ⁽¹⁾	-	ns
tCK	Clock(CLK) Period	5	-	6	-	ns
tCH	Clock High level width	0.45	-	0.45	-	tCKmin
tCL	Clock Low level width	0.45	-	0.45	-	tCKmin
tHP	Clock half period	Min(tCH,tCL)	-	Min(tCH,tCL)	-	ns
tDQSV	CS# Active to DQSM valid	-	12	-	12	ns
tDQSCK	Clock transition to DQSM valid	0.9	5	1	5.5	ns
tCSP	CS# High Between READ/WRITE	6	-	6	-	ns
tCSS	CS# Setup to next CLK Rising Edge	3	-	3	-	ns
tCSH	CS# Hold After CLK Falling Edge	2	-	2	-	ns
tIS	Input Setup	0.5	-	0.6	-	ns
tIH	Input Hold	0.5	-	0.6	-	ns
tDMV	Data Mask Valid (DQSM setup to end of initial latency)	0	-	0	-	ns
tCSM	Chip Select Maximum Low Time (~ 85°C)	-	4.0	-	4.0	us
tCSM	Chip Select Maximum Low Time (~ 125°C)	-	1.0	-	1.0	us

Note:

1. Ambient temperature is up to 105°C.

7.6.4 WRITE Timing Parameters (3.0V)

Symbol	Parameter	200MHz		166MHz		Unit
		Min.	Max.	Min.	Max.	
LC	Latency Counter (No Refresh Collision)	7 ⁽¹⁾	-	6 ⁽¹⁾	-	clock
tRWR	Read-Write Recovery Time	35 ⁽¹⁾	-	36 ⁽¹⁾	-	ns
tCK	Clock(CLK) Period	5	-	6	-	ns
tCH	Clock High level width	0.45	-	0.45	-	tCKmin
tCL	Clock Low level width	0.45	-	0.45	-	tCKmin
tHP	Clock half period	Min(tCH,tCL)	-	Min(tCH,tCL)	-	ns
tDQSV	CS# Active to DQSM valid	-	12	-	12	ns
tDQSCK	Clock transition to DQSM valid	0.9	6.0	1	6.5	ns
tCSP	CS# High Between READ/WRITE	6	-	6	-	ns
tCSS	CS# Setup to next CLK Rising Edge	3	-	3	-	ns
tCSH	CS# Hold After CLK Falling Edge	2	-	2	-	ns
tIS	Input Setup	0.5	-	0.6	-	ns
tIH	Input Hold	0.5	-	0.6	-	ns
tDMV	Data Mask Valid (DQSM setup to end of initial latency)	0	-	0	-	ns
tCSM	Chip Select Maximum Low Time (~ 85°C)	-	4.0	-	4.0	us
tCSM	Chip Select Maximum Low Time (~ 125°C)	-	1.0	-	1.0	us

Note:

1. Ambient temperature is up to 105°C.

8. PACKAGE TYPE INFORMATION

8.1 24-BALL THIN PROFILE FINE PITCH BGA 6X8MM 5X5 BALL ARRAY (B)

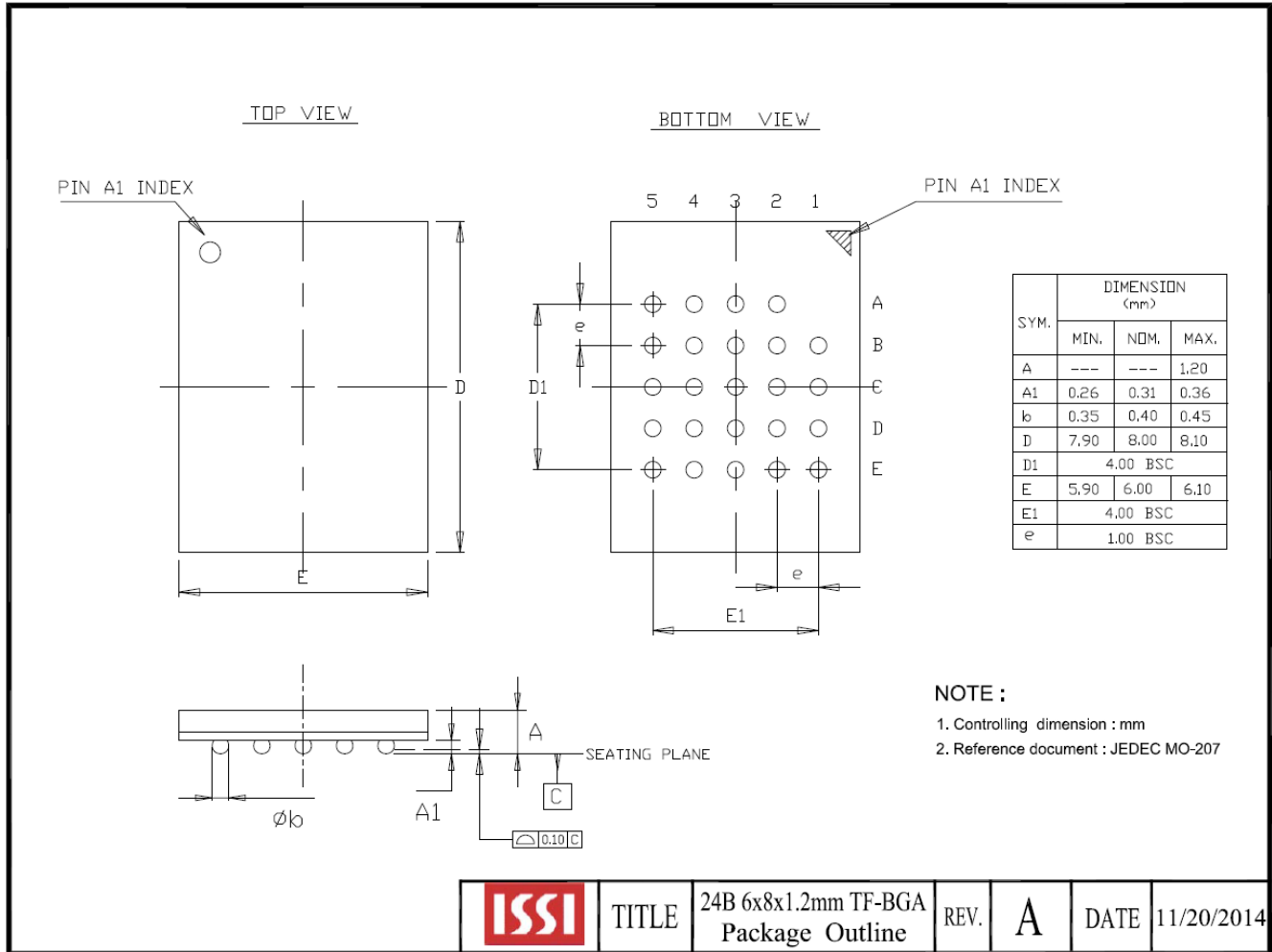

9. ORDERING INFORMATION – Valid Part Numbers

IS66 WVO 8M8 D ALL - 200 B L I

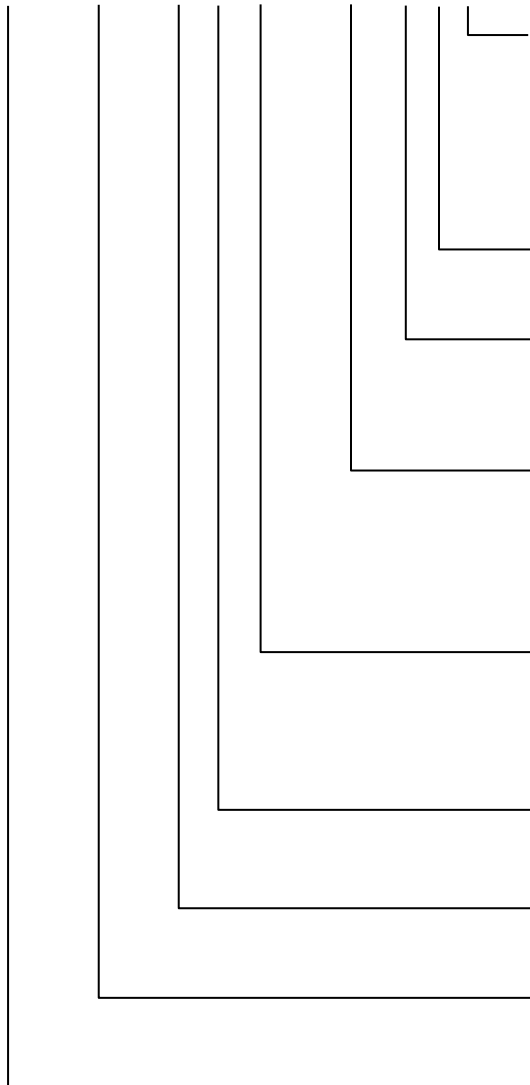

TEMPERATURE RANGE

I = Industrial (-40°C to +85°C)
A2 = Automotive Grade (-40°C to +105°C)
A3 = Automotive Grade (-40°C to +125°C)

PACKAGING CONTENT

L = RoHS compliant

PACKAGE Type ⁽¹⁾

B = 24-ball TFBGA 6x8mm 5x5 ball array
W = KGD (Call Factory)

Frequency

200 = 200MHz
166 = 166MHz
133 = 133MHz

VDD

ALL = 1.8V
BLL = 3.0V

Die Revision

D = die rev D

Density/Org.

8M8 = 8Mb x 8 = 64Mb

PSRAM Product Type.

WVO = OctalRAM

BASE PART NUMBER

IS = Integrated Silicon Solution Inc.

66 = PSRAM

67 = PSRAM for Automotive

**Industrial Temperature Range (-40°C to +85°C)**

Config.	Voltage	Frequency (MHz)	Order Part Number	Package
8Mbx8	1.8V	200	IS66WVO8M8DALL-200BLI	24-ball TFBGA 6x8mm 5x5 ball array
		166	IS66WVO8M8DALL-166BLI	24-ball TFBGA 6x8mm 5x5 ball array
	3.0V	200	IS66WVO8M8DBLL-200BLI	24-ball TFBGA 6x8mm 5x5 ball array
		166	IS66WVO8M8DBLL-166BLI	24-ball TFBGA 6x8mm 5x5 ball array

Automotive A3 Temperature Range (-40°C to +105°C)

Config.	Voltage	Frequency (MHz)	Order Part Number	Package
8Mbx8	1.8V	200	IS67WVO8M8DALL-200BLA2	24-ball TFBGA 6x8mm 5x5 ball array
		166	IS67WVO8M8DALL-166BLA2	24-ball TFBGA 6x8mm 5x5 ball array
	3.0V	200	IS67WVO8M8DBLL-200BLA2	24-ball TFBGA 6x8mm 5x5 ball array
		166	IS67WVO8M8DBLL-166BLA2	24-ball TFBGA 6x8mm 5x5 ball array

Automotive A3 Temperature Range (-40°C to +125°C)

Config.	Voltage	Frequency (MHz)	Order Part Number	Package
8Mbx8	1.8V	166	IS67WVO8M8DALL-166BLA3	24-ball TFBGA 6x8mm 5x5 ball array
	3.0V	166	IS67WVO8M8DBLL-166BLA3	24-ball TFBGA 6x8mm 5x5 ball array
		133	IS67WVO8M8DBLL-133BLA3	24-ball TFBGA 6x8mm 5x5 ball array

X-ON Electronics

Largest Supplier of Electrical and Electronic Components

Click to view similar products for [SRAM](#) category:

Click to view products by [ISSI](#) manufacturer:

Other Similar products are found below :

[CY6116A-35DMB](#) [CY7C1049GN-10VXI](#) [CY7C1461KV33-133AXI](#) [GS8161Z36DD-200I](#) [GS88237CB-200I](#) [RMLV0408EGSB-4S2#AA0](#)
[IS64WV3216BLL-15CTLA3](#) [IS66WVE4M16ECLL-70BLI](#) [PCF8570P](#) [K6F2008V2E-LF70000](#) [K6T4008C1B-GB70](#) [CY7C1353S-100AXC](#)
[AS6C8016-55BIN](#) [AS7C164A-15PCN](#) [515712X](#) [IS62WV51216EBLL-45BLI](#) [IS63WV1288DBLL-10HLI](#) [IS66WVE2M16ECLL-70BLI](#)
[IS66WVE4M16EALL-70BLI](#) [IS61WV102416DBLL-10TLI](#) [CY7C1381KV33-100AXC](#) [CY7C1460KV25-200BZI](#) [CY7C1373KV33-100AXC](#)
[CY7C1381KVE33-133AXI](#) [CY7C4121KV13-600FCXC](#) [GS882Z18CD-150I](#) [IS66WVC2M16ECLL-7010BLI](#) [7140LA35PDG](#)
[CY7C1380KV33-250AXC](#) [AS6C8016-55BINTR](#) [CY7C1370KV33-250AXC](#) [CY7C1370KVE33-167AXI](#) [7140LA100PDG](#) [AS7C34096B-](#)
[10TIN](#) [AS6C8016-55TIN](#) [IS62WV25616EALL-55TLI](#) [GS8128418B-167IV](#) [CY7C1460KV25-200BZXI](#) [CY7C1460KV25-167BZXI](#)
[CY7C1315KV18-333BZXC](#) [CY7C1370KV25-200AXC](#) [71421LA55JI8](#) [CY62158G30-45ZSXI](#) [CY62157G30-45ZSXI](#) [RMLV3216AGSD-](#)
[5S2#AA0](#) [CY62187G30-55BAXI](#) [CY62157G30-45ZXI](#) [IS61VVPS102436B-200B3LI](#) [IS66WVC2M16EALL-7010BLI](#)
[IS66WVE4M16EALL-70BLI-TR](#)