



IS66WVR4M8ALL/BLL

IS67WVR4M8ALL/BLL

**32Mb SerialRAM,
Continuous operation
1.8V/3.0V, 104MHZ, SPI & QPI
PROTOCOL**

32Mb SerialRAM

1.8V/3.0V, 104MHz, Continuous Operation, SPI & QPI Protocol

FEATURES

- **Industry Standard Serial Interface**

- SPI Protocol: 1-1-1 & 1-4-4 operation
- QPI protocol: 4-4-4 operation
- Low Signal Counts :6 Signal pins (CE#, CLK, SIO0~SIO3)

- **High Performance**

- Clock Rate:
33MHz(max) for normal read
104MHz(max) for fast read
- Always Continuous Operation through entire cell array (Wrap to 1st address after last address)
- Drive Strength: 50 ohm

- **Low Power Consumption**

- Single 1.65V to 1.95V Voltage Supply
- Single 2.7V to 3.6V Voltage Supply
- 15 mA Max. Active QPI Mode Read Current at 104MHz, 105°C
- 150 μ A typ. Standby Current

- **Hardware Features**

- **CLK Input:** Serial clock input
- **SIO0 – SIO3:**
Serial Data Input or Serial Data Output

- **Temperature Grades**

- Industrial: -40°C to +85°C
- Auto (A1) Grade: -40°C to +85°C
- Auto (A2) Grade: -40°C to +105°C

- **Industry Standard PACKAGE**

- K = 8-contact WSON 6x5mm
- T = 8-contact USON 4x3mm
- N = 8-pin SOIC 150mil
- KGD (Call Factory)
- Green Package (RoHS Compliant, Halogen-Free) and TSCA Compliant

GENERAL DESCRIPTION

The IS66/67WVR4M8ALL/BLL are integrated memory device containing 32Mb Pseudo Static Random Access Memory using a self-refresh DRAM array organized as 4M words by 8 bits.

The device supports SPI (Serial Peripheral Interface) & QPI (Quad Peripheral Interface) protocols, Very Low Signal Count (6 signal pins; CLK, CE#, and 4 SIOs), Hidden Refresh Operation, and Industrial temperature and Automotive A2 grade temperature.

In Read/Write operation, the address advances to next address automatically until CE# goes to HIGH, and wraps to 1st address after the last address.

In-Band Reset is supported instead of dedicated RESET# pin, and minimum transferred data size is 8bit.

PERFORMANCE SUMMARY

Read / Write Operation	
Maximum Clock Rate	104MHz
Maximum Clock to Access Time at 104MHz	7ns

Maximum Current Consumption		
Burst Read or Write (SPI mode, 33MHz)		8mA
Burst Read or Write (QPI mode, 104MHz)		15mA
Standby (I _{SB1} , 85°C)	3V	200 uA
	1.8V	200 uA

TABLE OF CONTENTS

FEATURES2

GENERAL DESCRIPTION3

PERFORMANCE SUMMARY3

TABLE OF CONTENTS4

1. PIN CONFIGURATION & Descriptions6

2. Block Diagram.....8

3. Power-up Initialization.....9

4. Interface Description10

 4.1 Address Space.....10

 4.2 Page Length..... **Error! Bookmark not defined.**

 4.3 DriveR Strength10

 4.4 POWER-ON STATUS10

 4.5 Command/Address Latching Truth10

 4.6 READ/WRITE Termination11

5. READ/WRITE OPERATIONS.....12

 5.1 SPI READ OPERATIONS12

 5.2 SPI WRITE OPERATIONS.....14

 5.3 QPI MODE15

 5.4 QPI Fast READ Operation.....16

 5.5 QPI WRITE Operation17

 5.6 QPI EXIT Operation.....17

 5.7 Read ID Operation.....18

 5.8 RESET Operation19

 5.9 In-BAND RESET Operation.....20

 5.10 Deep POWER DOWN MODE22

6. REGISTER.....24

 6.1 DEVICE IDENTIFICATION REGISTER24

7. ELECTRICAL CHARACTERISTICS.....25

 7.1 ABSOLUTE MAXIMUM RATINGS ⁽¹⁾25

 7.2 OPERATING RANGE25

 7.3 DC CHARACTERISTICS.....26

 7.4 AC Measurement Conditions.....27

 7.5 PIN CAPACITANCE (TA = 25°C, VCC=1.8V/ 3V, 1MHz)27

 7.6 AC CHARACTERISTICS.....28

 7.7 INPUT/OUTPUT TIMING.....29

8. PACKAGE TYPE INFORMATION.....30

 8.1 8- Contact Ultra-Thin Small Outline No-Lead (WSON) PACKAGE 6X5MM (K).....30

 8.2 8- Contact Ultra-Thin Small Outline No-Lead (USON) PACKAGE 4X3MM (T)31



8.3 8-Pin JEDEC 150mil Broad Small Outline Integrated Circuit (SOIC) Package (N).....32

9. ORDERING INFORMATION – Valid Part Numbers.....33

1. PIN CONFIGURATION & Descriptions

8-contact WSON 6 x 5mm, 8-contact USON 4 x 3mm



8-pin SOIC, 150mil

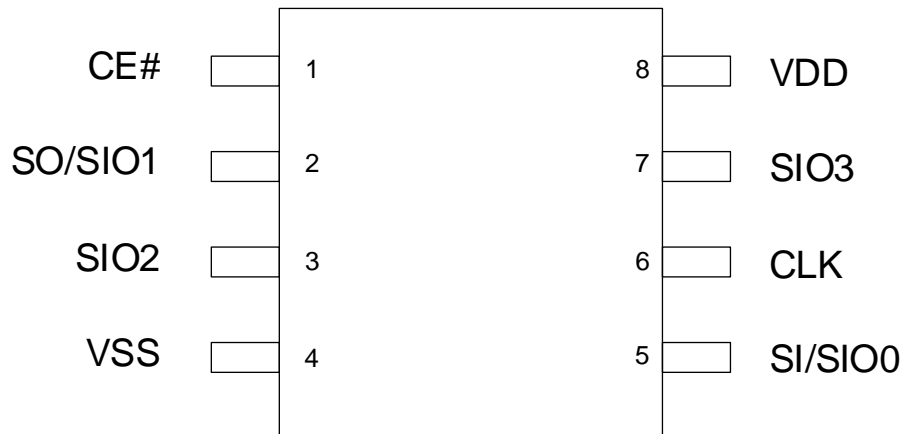



PIN DESCRIPTIONS

SYMBOL	TYPE	DESCRIPTION
CE#	INPUT	Chip Select:
SI/SIO0	INPUT/OUTPUT	Serial Data Input (SPI Mode) or Serial Data Input/Output (QPI Mode)
SO/SIO1	INPUT/OUTPUT	Serial Data Output (SPI Mode) or Serial Data Input/Output (QPI Mode)
SIO2, SIO3	INPUT/OUTPUT	RFU (SPI Mode) or Serial Data Input/Output (QPI Mode)
CLK	INPUT	Serial Data Clock: Synchronized Clock for input and output timing operations.
VDD	POWER	Power Supply
VSS	GROUND	Ground
RFU	-	Reserved for Future Use

2. Block Diagram

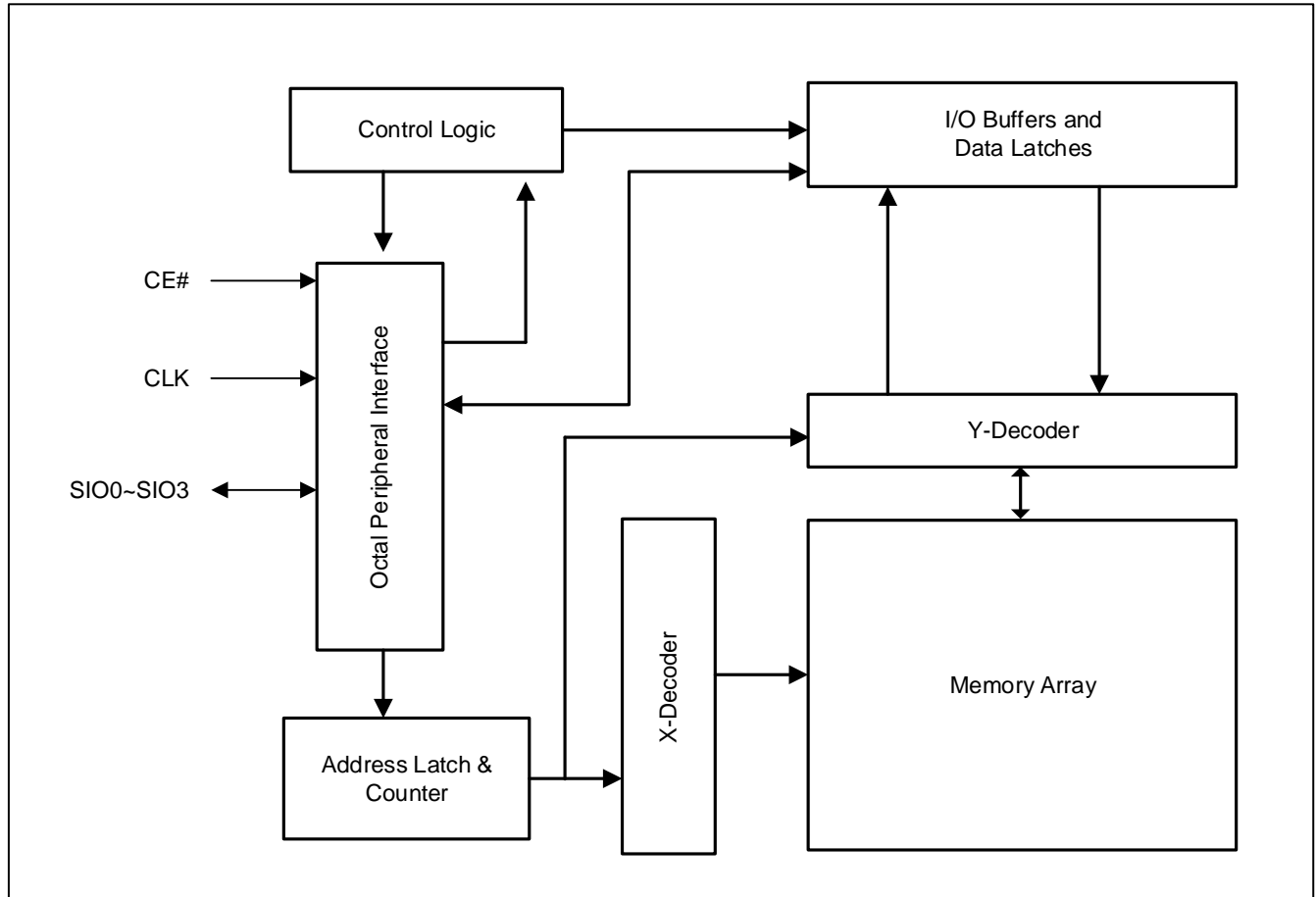

3. Power-up Initialization

The SPI/QPI includes on-chip voltage sensor used to start the self-initialization process. When VDD reaches a stable level at above the minimum VDD, the device will need 150us to complete its self-initialization process.

After the 150us period, the device will be ready for normal operation.

Figure 3.1 POWER-UP Timing

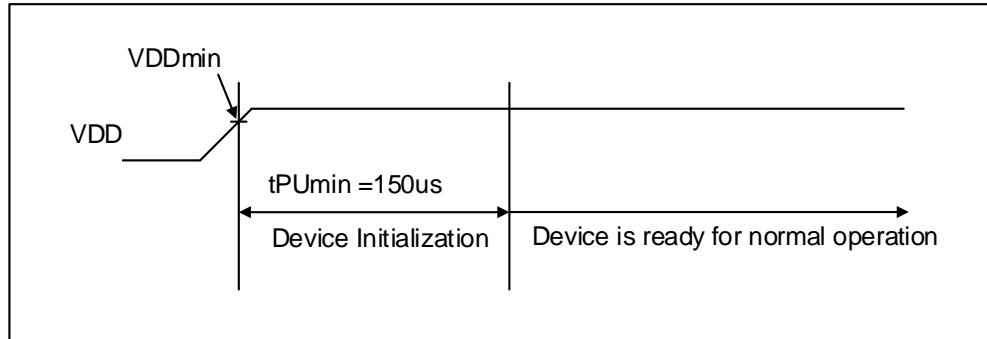

4. Interface Description

4.1 ADDRESS SPACE

Serial PSRAM device is byte-addressable. 32Mb device is addressed with A21 to A0.

4.2 DRIVER STRENGTH

Driver strength is 50 ohm measured at ½ VDD.

4.3 POWER-ON STATUS

The device powers up in SPI mode.

At least one clock pulse of CE# HIGH is needed before beginning any operations.

4.4 COMMAND/ADDRESS LATCHING TRUTH

The device recognizes the following commands specified by the various input methods.

Table 4.1 Commands recognized by the device

Command	SPI Mode						QPI Mode				
	Code	CMD	Add	Wait Cycle	DIO	Max Freq.	CMD	Add	Wait Cycle	DIO	Max Freq.
Read	03h	S	S	0	S	33	Q	Q	4	Q	84
Fast Read	0Bh	S	S	8	S	104	Q	Q	4	Q	84
Quad IO Read	EBh	S	Q	6	Q	104	Q	Q	6	Q	104
Write	02h	S	S	0	S	104	Q	Q	0	Q	104
Quad IO Write	38h	S	Q	0	Q	104	Q	Q	0	Q	104
Enter QPI mode	35h	S	-	-	-	-	NA				
Exit QPI mode	F5h	NA					Q	-	-	-	104
RESET Enable	66h	S	-	-	-	104	Q	-	-	-	104
RESET	99h	S	-	-	-	104	Q	-	-	-	104
Read ID	9Fh	S	S	0	S	104	Q	-	6	Q	104
DPD mode Entry	B9h	S	-	-	-	104	Q	-	-	-	104

Note:

1. 03h command in QPI mode is the same with and 0Bh command in QPI Mode.

4.5 READ/WRITE TERMINATION

All reads and writes must be followed immediately by a clock pulse of CE# HIGH in order to terminate the read and writes, and set the device into standby status.

CE# must transition to HIGH after the tHD (Clock rising edge to CE# HIGH).

Figure 4.1 Command Termination (Standard Device)

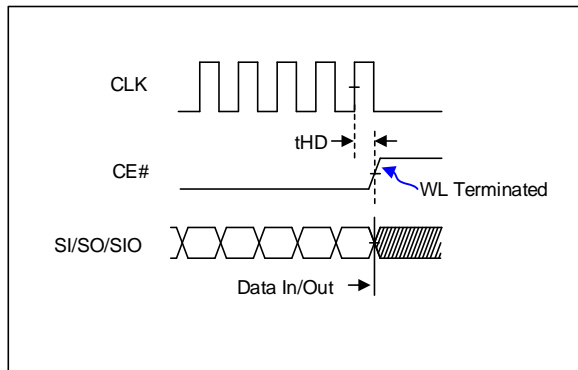

As for optional device, one more clock is required to terminate operation with CE# not active setup time and hold time.

Call factory for optional device.

Figure 4.2 Command Termination (Optional Device)

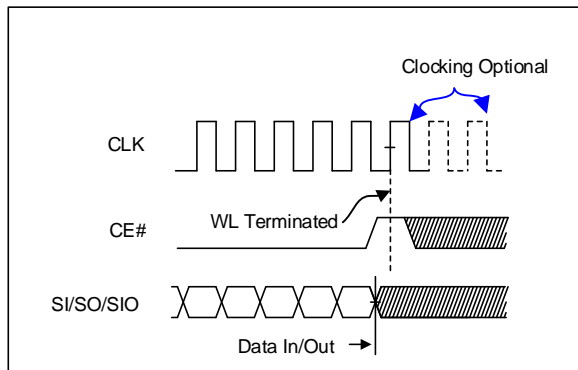

5. READ/WRITE OPERATIONS

For all reads, data will be available for t_{ACLK} after the falling edge of clock continuously until CE# goes to HIGH. After the last address of cell array, it automatically wraps to 1st address of the cell array.

For all writes, the address will also continuously advance to next address until CE# goes to HIGH. After the last address of cell array, it automatically wraps to 1st address of the cell array.

5.1 SPI READ OPERATIONS

For all reads, data will be available for t_{ACLK} after the falling edge of clock. SPI reads can be done in three ways:

03h: Serial CMD, Serial IO, slow frequency (1-1-1, 0 Wait Cycle)

0Bh: Serial CMD, Serial IO, fast frequency (1-1-1, 8 Wait Cycles)

EBh: Serial CMD, Quad IO, fast frequency (1-4-4, 6 Wait Cycles)

Figure 5.1 SPI Read, 03h (1-1-1, Max frequency: 33MHz)

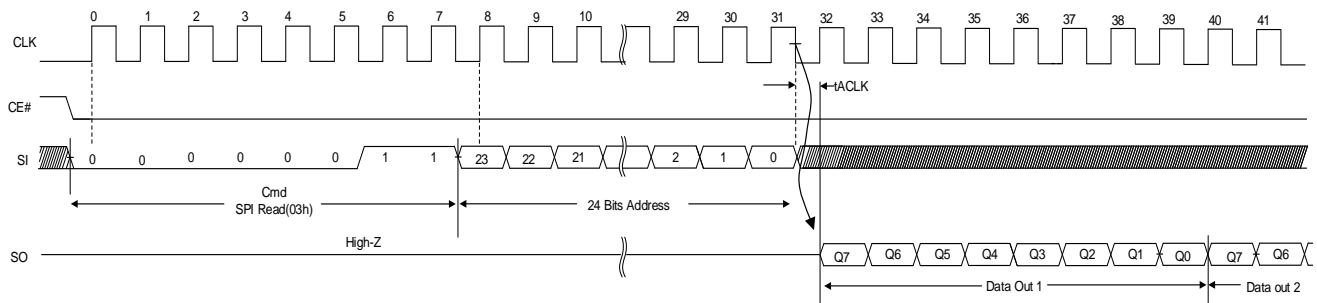

Note:

1. Data out goes to High-Z after CE# transitions to HIGH (t_{HZ}).

Figure 5.2 SPI Fast Read, 0Bh (1-1-1, Max frequency: 104MHz)

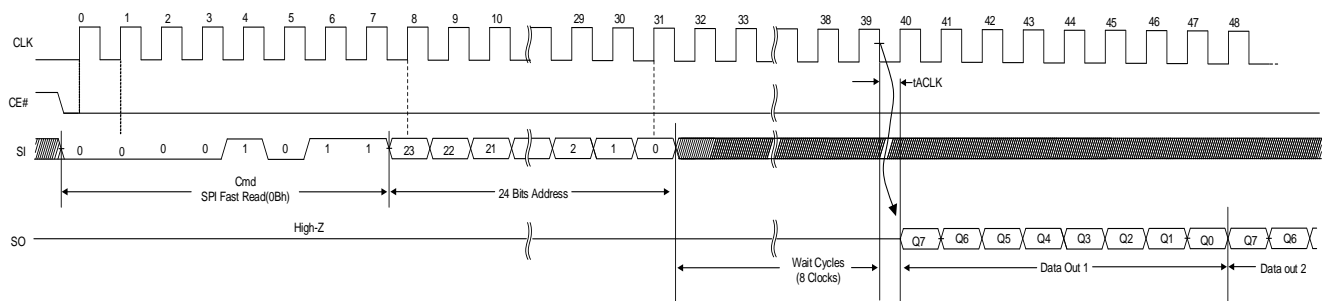

Note:

1. Data out goes to High-Z after CE# transitions to HIGH (t_{HZ}).

Figure 5.3 SPI Fast Quad IO Read, EBh (1-4-4, Max frequency: 104MHz)

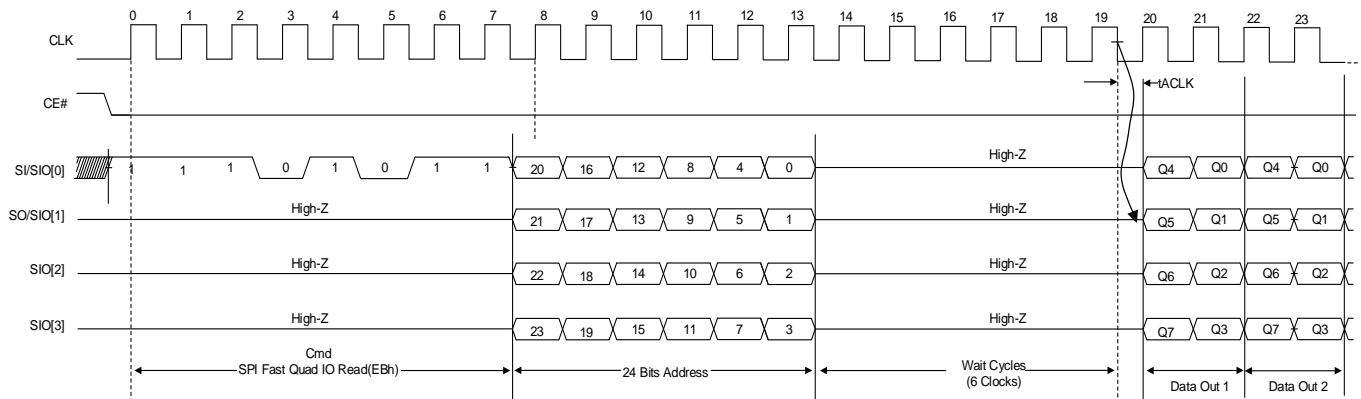

Note:

1. Data out goes to High-Z after CE# transitions to HIGH (tHZ).

5.2 SPI WRITE OPERATIONS

02h: Serial CMD, Serial IO, slow frequency (1-1-1, 0 Wait Cycle)

38h: Serial CMD, Quad IO, fast frequency (1-4-4, 0 Wait Cycles)

Figure 5.4 SPI Write Command 02h (1-1-1)

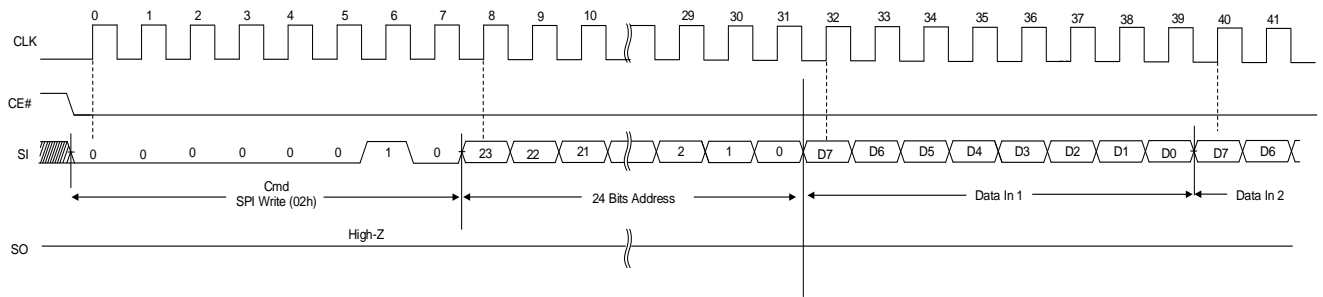
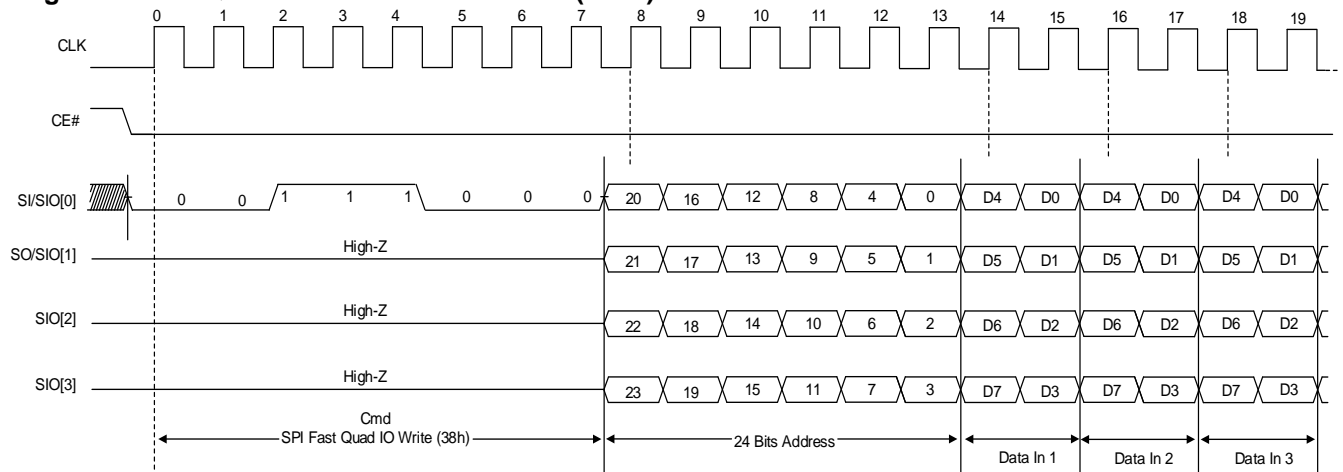

Figure 5.5 SPI Quad IO Write command 38h (1-4-4)



5.3 QPI MODE

35h command switches the device into QPI mode.

Figure 5.6 QPI Mode Enable, 0x35

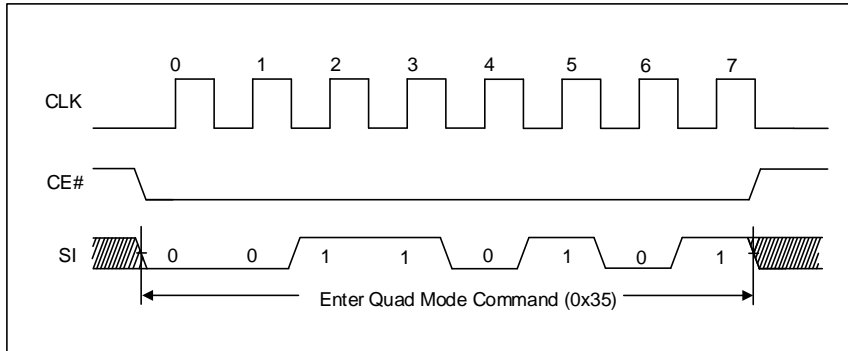

5.4 QPI FAST READ OPERATION

For all reads in QPI mode, data will be available for t_{ACLK} after the falling edge of clock. QPI reads can be done in two ways:

- 03h: Quad CMD, Quad IO, fast frequency (up to 84MHz, 4 Wait Cycles)
- 0Bh: Quad CMD, Quad IO, fast frequency (up to 84MHz, 4 Wait Cycles)
- EBh: Quad CMD, Quad IO, fast frequency (up to 104MHz, 6-Wait Cycles)

Figure 5.7 QPI Fast Read, 03h/0Bh (Max Frequency: 84MHz)

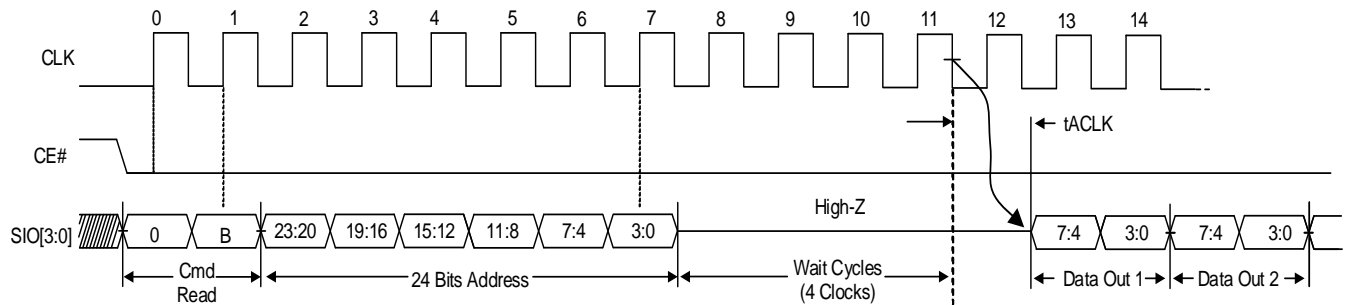

Note:

1. Data out goes to High-Z after CE# transitions to HIGH (tHZ).

Figure 5.8 QPI Fast Read, EBh (Max Frequency: 104MHz)

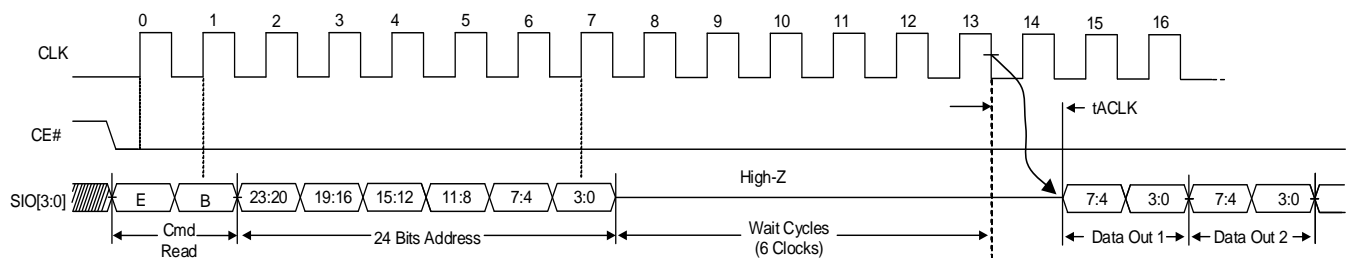

Note:

1. Data out goes to High-Z after CE# transitions to HIGH (tHZ).

5.5 QPI WRITE OPERATION

In QPI mode, either 02h or 38h command can be used for QPI write operation. It has nothing to do with maximum frequency.

Figure 5.9 QPI Write 02h or 38h

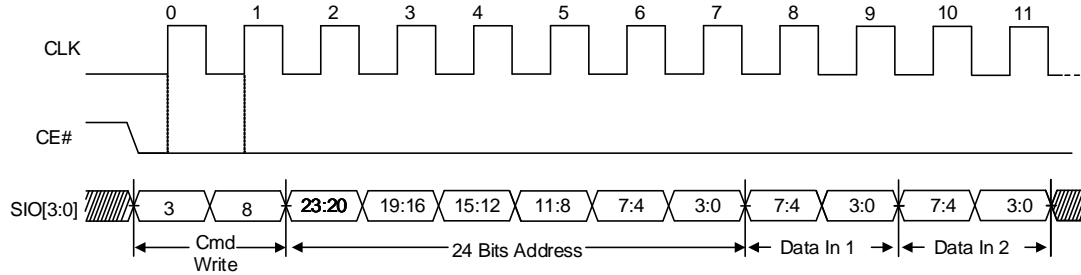

5.6 QPI EXIT OPERATION

This command will switch the device back into SPI mode.

Figure 5.10 QPI Mode Exit, F5h (Only available in QPI mode)

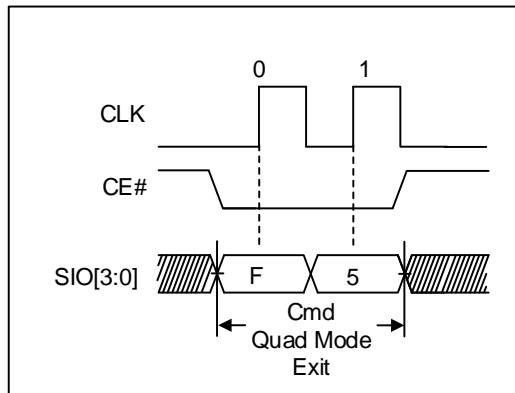

5.7 READ ID OPERATION

In SPI mode, this command is similar to Fast Read. But 24-bit address cycles are “don’t care” and there are no wait cycles between address and data.

In QPI mode, there is no address cycles, but there are 6 wait cycles between command and data.

The data is wrapped to bit 7 of MF ID data again after bit 0 of EID data until CE# goes to HIGH.

Figure 5.11 SPI Read ID, 9Fh

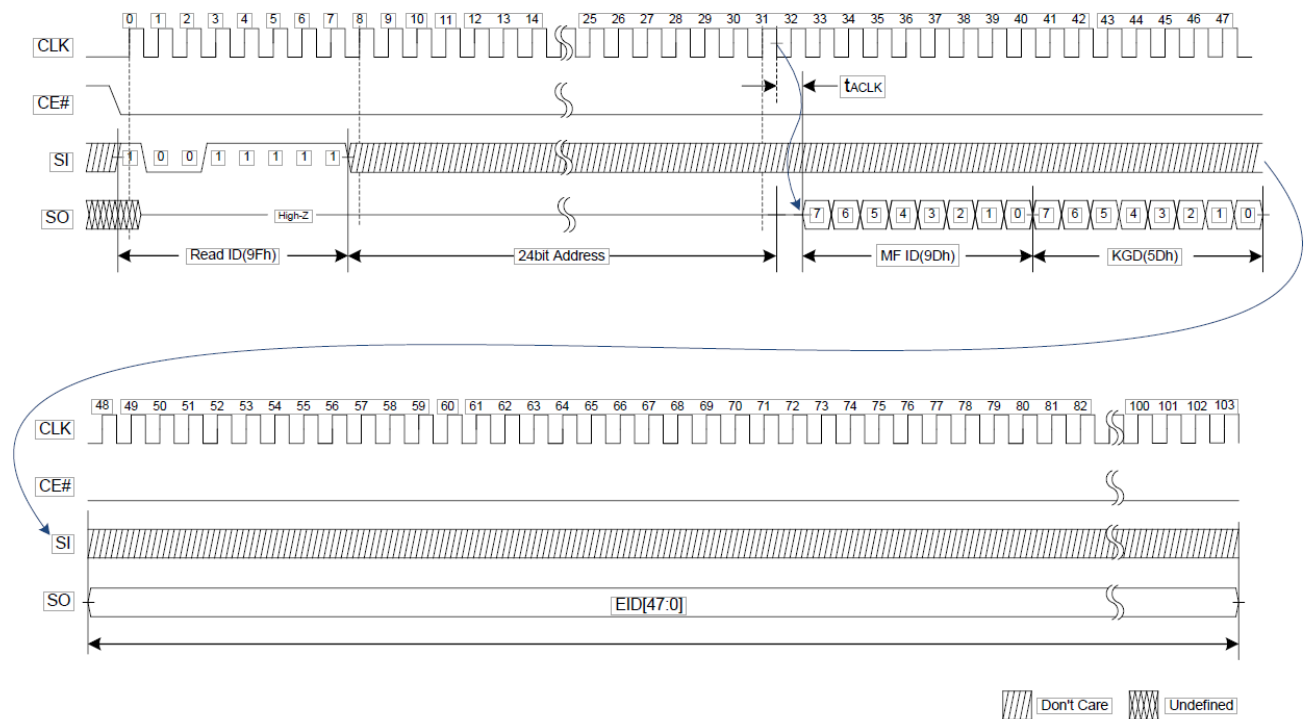
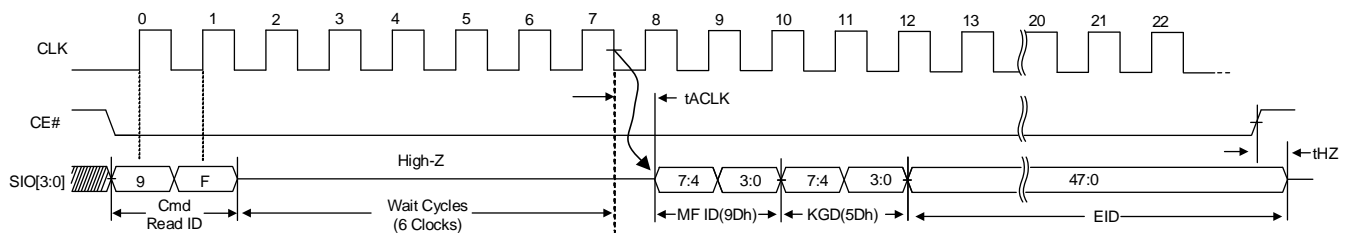

Figure 5.12 QPI Read ID, 9Fh



KGD [7:0]	Known Good Die
'b0101_0101	FAIL
'b0101_1101	PASS

5.8 RESET OPERATION

Software RESET

The software reset operation is used as a system reset that puts the device in SPI standby mode, which is also the default mode after power up. This operation consists of two commands: RESET Enable (0x66h) and RESET (RST, 0x99).

The reset operations requires the RESET ENABLE command to be followed by the RESET command. Any other command other than the RESET command after the RESET ENABLE command will disable the RESET ENABLE procedure.

Figure 5.13 SPI RESET

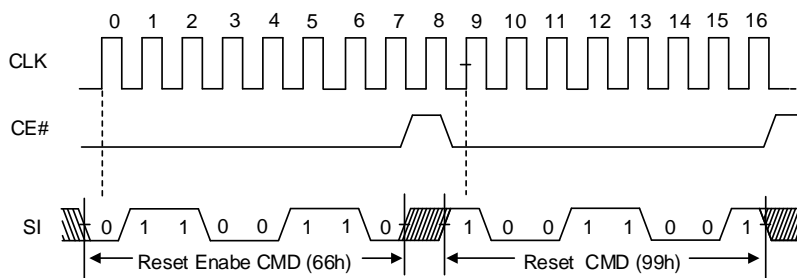
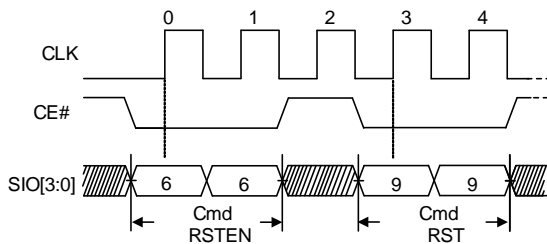

Figure 5.14 QPI RESET



5.9 IN-BAND RESET OPERATION

The device offers an additional feature of In-Band RESET function, which uses existing SPI signals to initiate a hardware reset, which is different from existing software reset/hardware reset (dedicated RESET# pin);

- Existing software reset commands often depend on the device being in a particular mode before they are effective. This makes software based reset sequences depend on slave device and mode.
- Dedicated RESET# pin requires additional pin over traditional 8-pins of SPI device. Also it requires 1 more signal for reset operation.

In Band-RESET operation requires 2-signal pins; CE# and SIO0.

- CE# is driven active low to select the SPI slave (note1)
- Clock (CLK) remains stable in either a high or low state(note 2)
- SIO0 is driven low by the bus master, simultaneously with CE# going active low.....(note 3)
- CE# is driven inactive ... (note 4)
- Repeat the above 4 steps, each time alternating the state of SIO0.
- After the fourth CE# pulse, the slave triggers its internal reset.....(note 5)

Note 1 This powers up the SPI slave

Note 2 This prevents any confusion with a command, as no command bits are transferred (clocked)

Note 3 No SPI bus slave drives SIO0 during CE# low before a transition of clock. Slave streaming output active is not allowed until after the first edge of clock.

Note 4 The slave captures the state of SIO0 on the rising edge of CE#

Note 5 SIO0 is low on the first CE#, high on the second, low on the third, high on the fourth ... (This provides a 5th, unlike random noise)

NOTE:

This reset sequence is not intended to be used at normal power on, but to be used only when the device is not responding to the system. This reset sequence will be operational from any state that the device may be in. During the reset process, the device will ignore any chip select (command). In Band-Reset function is supported by optional device (option R) only.

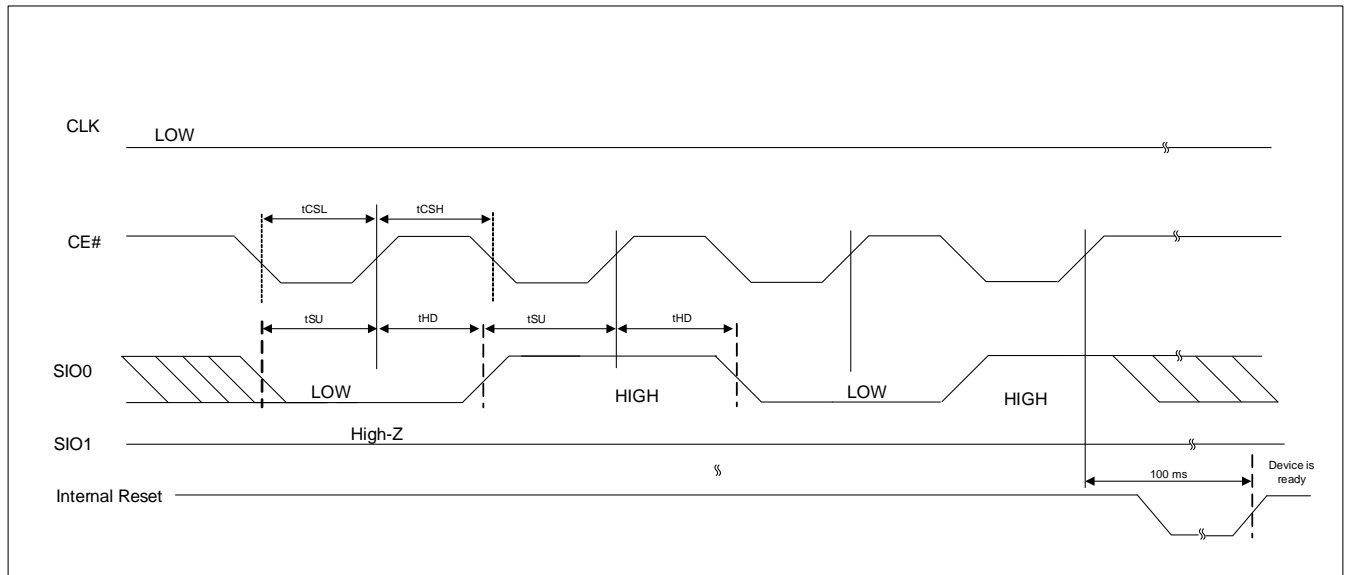
Figure 5.15 Timing for In-Band RESET Operation

Table 5.1 In-Band RESET Timing Parameters

Parameter	Symbol	Min	Max	Units
CE# Low Pulse	t_{CSL}	500	--	ns
CE# High Pulse	t_{CSH}	500	--	ns
Setup Time	t_{SU}	5	--	ns
Hold Time	t_{HD}	5	--	ns

5.10 DEEP POWER DOWN MODE

The Deep Power-down instruction (B9h) is for setting the device on the minimizing the power consumption (enter into Power-down mode). During this mode, standby current is reduced from I_{sb1} to I_{sb2} after t_{DPDIN} .

Figure 5.16 DEEP POWR DOWN ENTRY Timing (SPI MODE)

Figure 5.17 DEEP POWR DOWN ENTRY Timing (QPI MODE)

Figure 5.18 DEEP POWER DOWN EXIT Timing

Table 5.2 DEEP POWER DOWN Timing Parameters

Parameter	Description	Min	Max	Unit
tDPDIN	Deep Power Down Instruction (B9h) to DPD power level	150	-	us
tDPDX	CE# Low period to exit from Deep Power Down	200	-	ns
tDPDOUT	CE# Low then High to Standby wakeup time	-	150	us

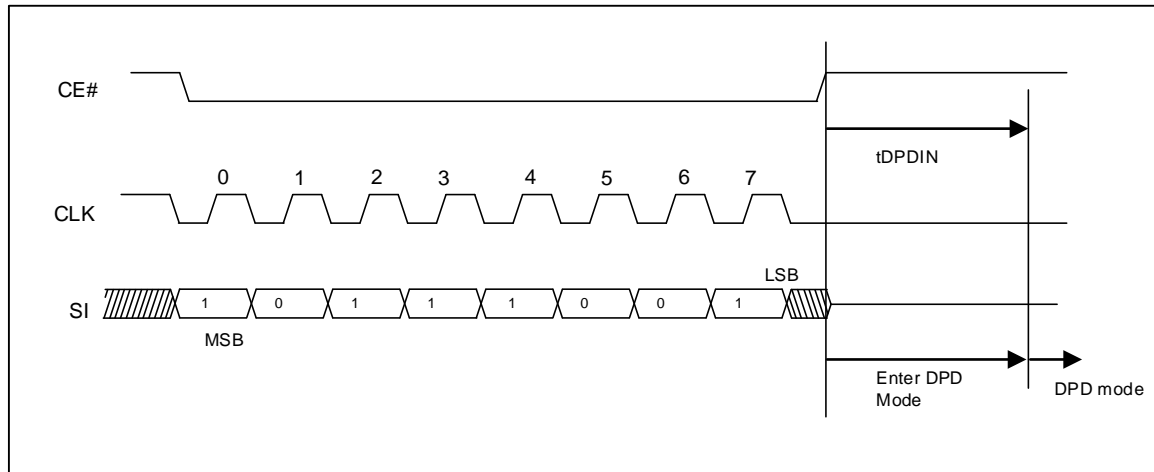
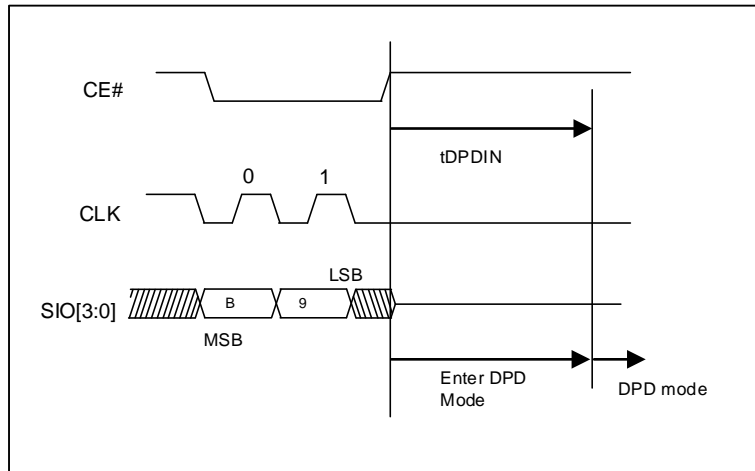
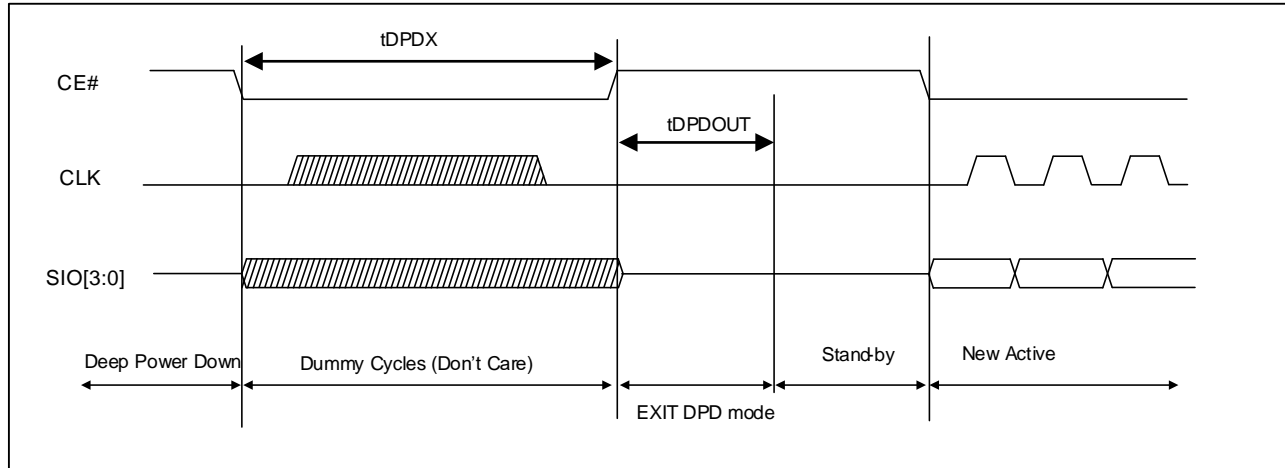
6. REGISTER

The device has 8-bit Configuration Register and 64 bit ID Register.

6.1 DEVICE IDENTIFICATION REGISTER

It is a read only, non-volatile, word register that provides device information. The device information fields can be identified as below.

- a. Manufacturer
- b. KGD Test
 - i. Not Passed Yet (55h)
 - ii. Passed (5Dh)
- c. Density

Table 6.2 ID Register

Bits	Function	Value
63 - 56	Manufacturer	1001 1101 (9Dh) = ISSI
55 - 48	KGD Test	0101 0101 (55h) = Not Passed Yet. 0101 1101 (5Dh) = PASS Default value on this register is (0x55 = Not Passed Yet). After the all tests passed, then programmed as 0x5D (Pass) in manufacturing process.
47 - 45	Device Density	000 = 8Mb 001 = 16Mb 010 = 32Mb 011~111 = Reserved.
44 - 0	Reserved	Reserved

7. ELECTRICAL CHARACTERISTICS

7.1 ABSOLUTE MAXIMUM RATINGS ⁽¹⁾

Storage Temperature		-65°C to +150°C
Input Voltage with Respect to Ground on All Pins	ALL	-0.3V to V _{CC} + 0.3V
	BLL	-0.5V to V _{CC} + 0.3V
All Output Voltage with Respect to Ground	ALL	-0.3V to V _{CC} + 0.5V
	BLL	-0.5V to V _{CC} + 0.5V
V _{CC}	ALL	-0.5V to +2.5V
	BLL	-0.5V to +6.0V

Notes:

1. Applied conditions greater than those listed in “Absolute Maximum Ratings” may cause permanent damage to the device. This is a stress rating only and functional operation of the device at these or any other conditions above those indicated in the operational sections of this specification is not implied. Exposure to absolute maximum rating conditions for extended periods may affect reliability.

7.2 OPERATING RANGE

Operating Temperature	Industrial Grade	-40°C to 85°C
	Automotive Grade A1	-40°C to 85°C
	Automotive Grade A2	-40°C to 105°C
V _{CC} Power Supply	IS66/67WVR4M8 ALL	1.65V (V _{MIN}) –1.95V (V _{MAX}); 1.8V (Typ)
	IS66/67WVR4M8 BLL	2.7V (V _{MIN}) –3.6V (V _{MAX}); 3.0V (Typ)

7.3 DC CHARACTERISTICS

Symbol	Parameter		Min.	Typ.	Max.	Units	Test Conditions
V _{CC}	3V		2.7	3.0	3.6	V	
	1.8V		1.65	1.8	1.95		
I _{CC}	Average Operating Current (85°C)	SPI@33MHz	-	-	8	mA	CE# ≤ V _{CC} - 0.2V, Others at 0.2V or V _{CC} - 0.2V, I _{I/O} = 0mA, f=max
		QPI@104MHz	-	-	15		
	Average Operating Current (105°C)	SPI@33MHz	-	-	8		
		QPI@104MHz	-	-	15		
I _{SB1}	V _{CC} Standby Current CMOS (85°C)	3V	-	150	200	μA	CE# = V _{CC} , V _{IN} = GND or V _{CC}
		1.8V	-		200		
	V _{CC} Standby Current CMOS (105°C)	3V	-		250		
		1.8V	-		250		
I _{SB2}	Deep Power Down Current (85°C)	3V	-	-	30	μA	CE#, V _{CC} = 3.6V
		1.8V	-	-	20		
	Deep Power Down Current (105°C)	3V	-	-	50	μA	CE#, V _{CC} = 1.9V
		1.8V	-	-	30		
V _{IL} (¹)	Input Low Voltage	3V	-0.5	-	0.3V _{CC}	V	
		1.8V	-0.2	-	0.4		
V _{IH} (¹)	Input High Voltage	3V	0.7V _{CC}	-	V _{CC} + 0.3	V	
		1.8V	V _{CC} - 0.4	-	V _{CC} + 0.2		
V _{OL}	Output Low Voltage		-	-	0.2V _{CC}	V	I _{OL} = 200 μA
V _{OH}	Output High Voltage		0.8V _{CC}	-	-	V	I _{OH} = -200 μA
I _{LI}	Input Leakage Current		-	-	-	±1	V _{IN} = 0V to V _{CC}
I _{LO}	Output Leakage Current		-	-	-	±1	V _{IN} = 0V to V _{CC}

Note:

1. Typical values are included for reference only and are not guaranteed or tested. Typical values are measured at V_{CC} = V_{CC} (Typ), TA=25°C.

7.4 AC MEASUREMENT CONDITIONS

Parameter	Min	Max	Units
Output Load Capacitance, CL		30	pF
Input Rise and Fall Slew rates (0.2*VCC to 0.8*VCC)	1.5		V/ns
Input Pulse Voltage	0.1*VCC to 0.9*VCC		V
Input Timing Reference Voltages	VCC/2		V
Output Timing Reference Voltages	VCC/2		V

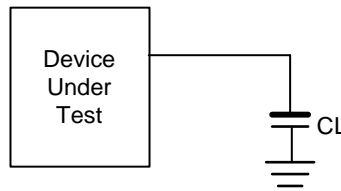
Figure 7.1 Test Setup

7.5 PIN CAPACITANCE (TA = 25°C, VCC=1.8V/ 3V, 1MHZ)

Symbol	Parameter	Test Condition	Min	Typ	Max	Units
C _{IN}	Input Capacitance (CE#, CLK)	V _{IN} = 0V	-	-	6	pF
C _{IN/OUT}	Input/Output Capacitance (SIO0~SIO3)	V _{IN/OUT} = 0V	-	-	8	pF

Note:

1. These parameters are characterized and not 100% tested.

7.6 AC CHARACTERISTICS

Parameter	Symbol	Min.	Max.	Unit
Clock Cycle Time	tCLK@33MHz	30	-	ns
	tCLK@104MHz	10	-	ns
Clock Low width	tCH	0.45	0.55	tCLK
Clock High width	tCL	0.45	0.55	tCLK
Clock Rise/Fall Slew Rates ⁽¹⁾	tR/tF	0.5	-	V/ns
CE# Setup time to Active CLK edge	tCSP	3	-	ns
Input Setup time to Active CLK edge	tSP	2.5	-	ns
Input Hold time from\ Active CLK edge	tHD	2	-	ns
CLK falling to Output Valid	tACLK		7	ns
Output Hold time from CLK falling	tOH	1.5		ns
Chip Disable to DQ Output High-Z	tHZ	-	7	ns
CE# High between Subsequent operations	tCPH	1		tCLK
Chip Select Maximum Low Time (~ 85°C)	tCEM	-	4	us
Chip Select Maximum Low Time (~ 105°C)		-	1	us

Note:

- Value is guaranteed by design and/or characterization, not 100% tested in production.

7.7 INPUT/OUTPUT TIMING

Figure 7.2 Input Timing

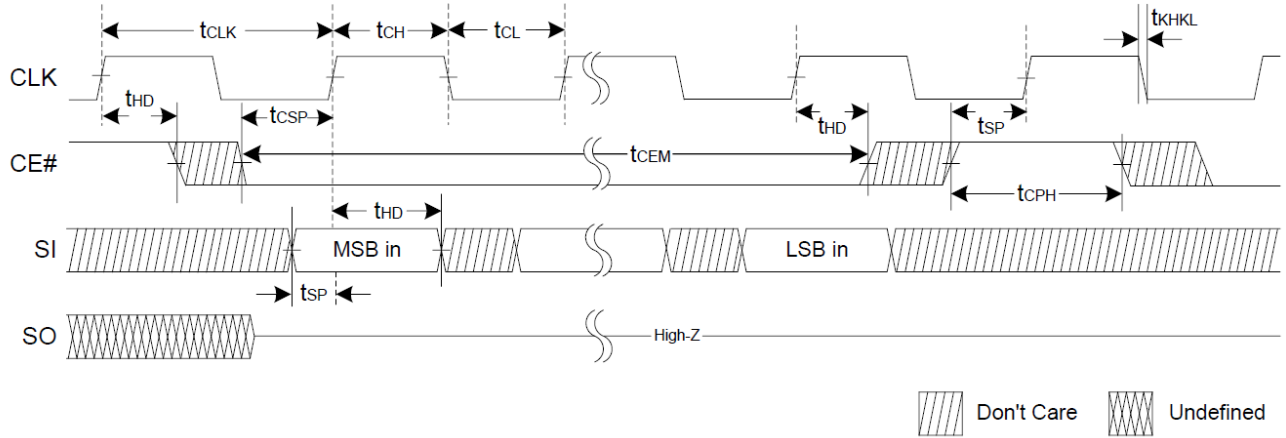
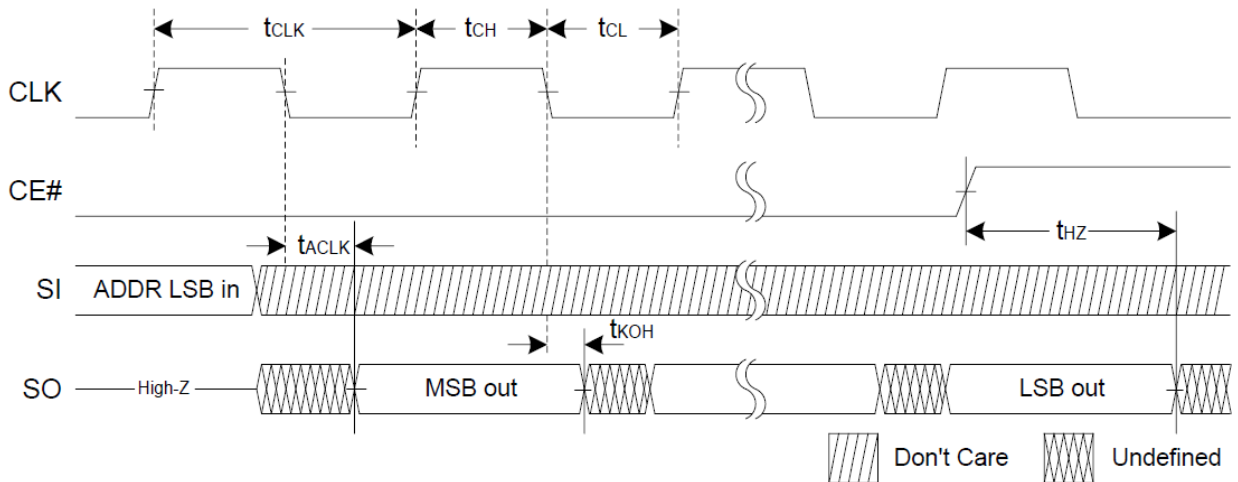
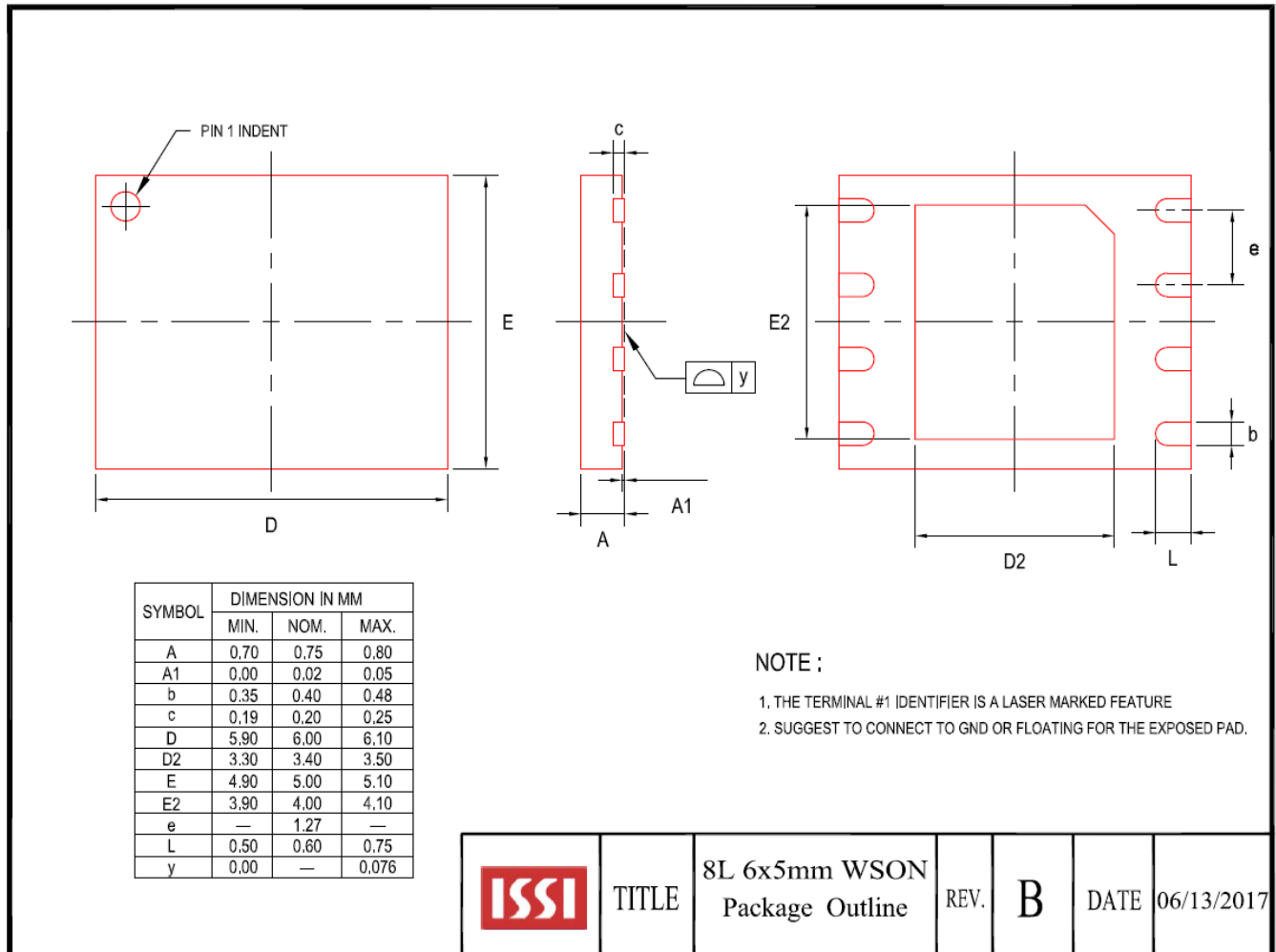

Figure 7.3 Output Timing



8. PACKAGE TYPE INFORMATION

8.1 8- CONTACT ULTRA-THIN SMALL OUTLINE NO-LEAD (WSON) PACKAGE 6X5MM (K)



Note:

1. Please [click here](#) to refer to Application Note (AN25D011, Thin USON/WSON/XON package handling precautions) for assembly guidelines.

8.2 8- CONTACT ULTRA-THIN SMALL OUTLINE NO-LEAD (USON) PACKAGE 4X3MM (T)

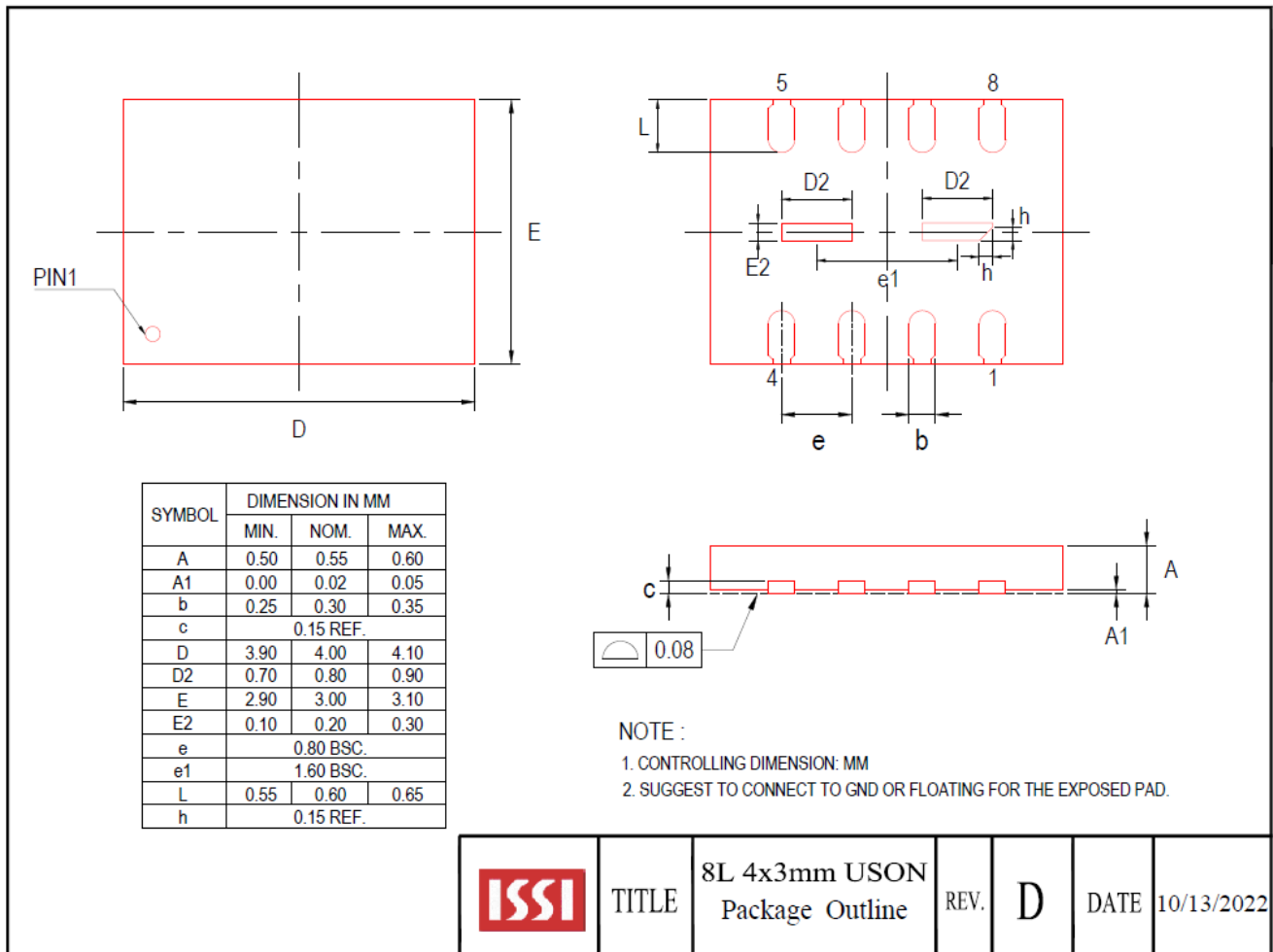

Note:

1. Please [click here](#) to refer to Application Note (AN25D011, Thin USON/WSON/XSON package handling precautions) for assembly guidelines.

8.3 8-PIN JEDEC 150MIL BROAD SMALL OUTLINE INTEGRATED CIRCUIT (SOIC) PACKAGE (N)

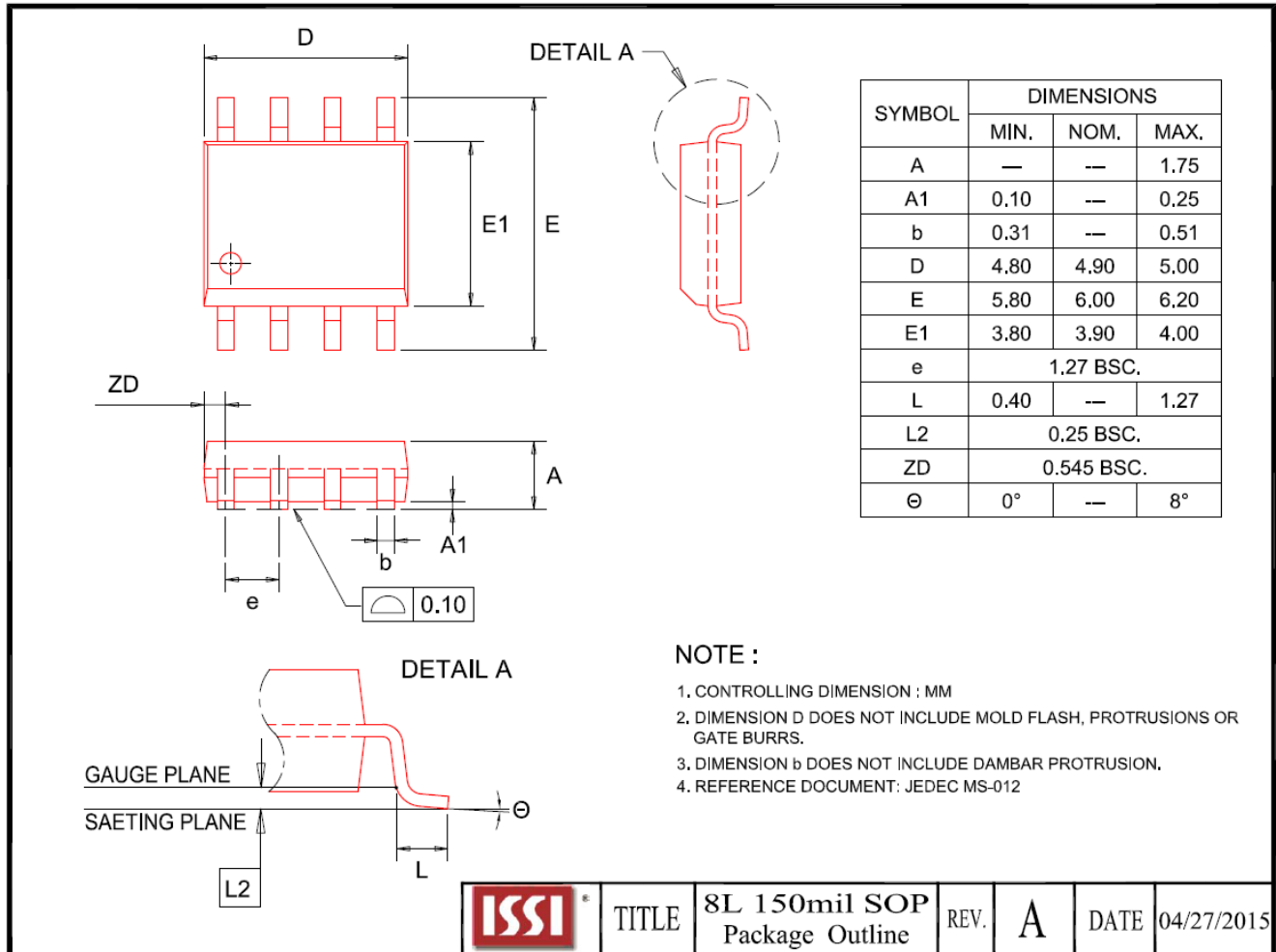

9. ORDERING INFORMATION – Valid Part Numbers

IS66 WVR 4M8 _ ALL - _ 104 N L I

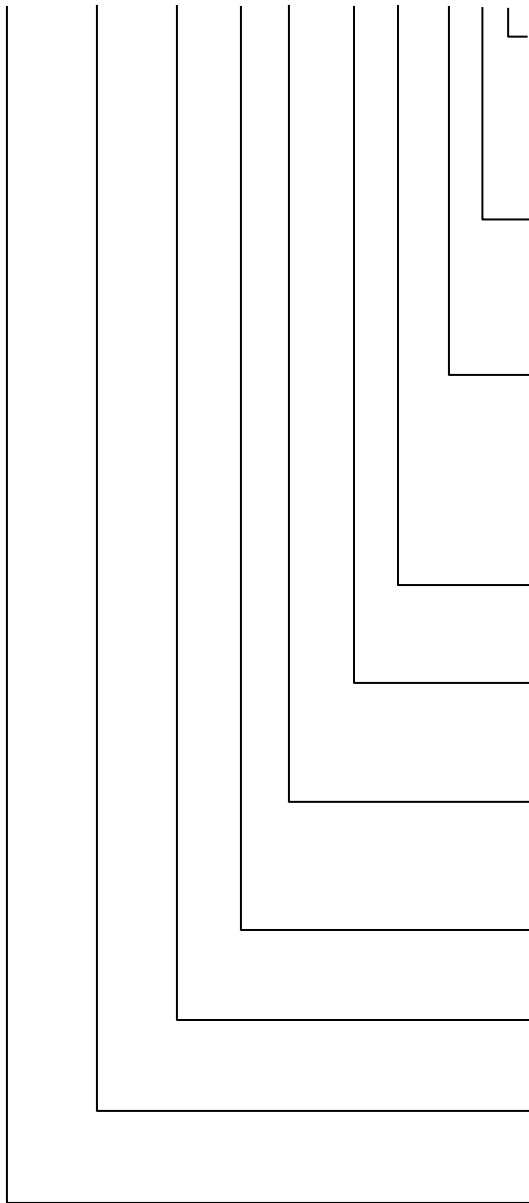

TEMPERATURE RANGE

I = Industrial (-40°C to +85°C)
 A1 = Automotive Grade (-40°C to +85°C)
 A2 = Automotive Grade (-40°C to +105°C)

PACKAGING CONTENT

L = Green Package (RoHS Compliant, Halogen-free) and TSCA Compliant

PACKAGE Type

N = 8-pin SOIC 150mil
 K = 8-contact WSON 6x5mm
 T = 8-contact USON 4x3mm
 W = KGD (Call Factory)

Frequency

104 = 104MHz

Option

Blank = No In-Band Reset supported
 R = In-Band Reset supported (Call Factory)

VDD

ALL = 1.8V
 BLL = 3.0V

Die Revision

Blank = First Gen.

Density/Org.

4M8 = 4Mbx8=32Mb

PSRAM Product Type.

WVR = SerialRAM, Continuous operation

BASE PART NUMBER

IS = Integrated Silicon Solution Inc.
 66 = PSRAM
 67 = PSRAM for Automotive

Industrial Temperature Range (-40°C to +85°C)

Config.	Voltage	Frequency (MHz)	Order Part Number	Package
4Mbx8	1.8V	104	IS66WVR4M8ALL-104KLI	8-contact WSON 6x5mm
			IS66WVR4M8ALL-104TLI	8-contact USON 4x3mm
			IS66WVR4M8ALL-104NLI	8-pin SOIC 150mil
	3.0V	104	IS66WVR4M8BLL-104KLI	8-contact WSON 6x5mm
			IS66WVR4M8BLL-104TLI	8-contact USON 4x3mm
			IS66WVR4M8BLL-104NLI	8-pin SOIC 150mil

Automotive A1 Temperature Range (-40°C to +85°C)

Config.	Voltage	Frequency (MHz)	Order Part Number	Package
4Mbx8	1.8V	104	IS67WVR4M8ALL-104KLA1	8-contact WSON 6x5mm
			IS67WVR4M8ALL-104TLA1	8-contact USON 4x3mm
			IS67WVR4M8ALL-104NLA1	8-pin SOIC 150mil
	3.0V	104	IS67WVR4M8BLL-104KLA1	8-contact WSON 6x5mm
			IS67WVR4M8BLL-104TLA1	8-contact USON 4x3mm
			IS67WVR4M8BLL-104NLA1	8-pin SOIC 150mil

Automotive A2 Temperature Range (-40°C to +105°C)

Config.	Voltage	Frequency (MHz)	Order Part Number	Package
4Mbx8	1.8V	104	IS67WVR4M8ALL-104KLA2	8-contact WSON 6x5mm
			IS67WVR4M8ALL-104TLA2	8-contact USON 4x3mm
			IS67WVR4M8ALL-104NLA2	8-pin SOIC 150mil
	3.0V	104	IS67WVR4M8BLL-104KLA2	8-contact WSON 6x5mm
			IS67WVR4M8BLL-104TLA2	8-contact USON 4x3mm
			IS67WVR4M8BLL-104NLA2	8-pin SOIC 150mil

X-ON Electronics

Largest Supplier of Electrical and Electronic Components

Click to view similar products for [DRAM](#) category:

Click to view products by [ISSI](#) manufacturer:

Other Similar products are found below :

[M366S0924FTS-C7A00](#) [MT52L256M32D1PF-107 WT:B](#) [HM514100AZ-80](#) [IS42VM16400M-75BLI](#) [K4S560432C-TC75](#) [ATCA-7360-MEM-4G](#) [MN41C4256A-07](#) [DEMT46H128M16LFCK6ITA](#) [S27KL0641DABHB020](#) [AS4C64M16D1A-6TCN](#) [AS4C256M8D2-25BIN](#) [MT52L256M32D1PF-107 WT:B TR](#) [S27KS0641DPBHV020](#) [AS4C64M32MD2-25BCN](#) [AS4C128M16MD2A-25BIN](#) [IS43LR16800G-6BL](#) [W97AH6KBVX2I](#) [MT44K16M36RB-125E:A TR](#) [IS45S32800J-7TLA2](#) [MT42L32M32D1HE-18 IT:D](#) [IS66WVH32M8DALL-166B1LI](#) [SQR-SD4I8G2K6SNBCB](#) [S27KL0642DPBHI023](#) [S27KL0642DPBHI020](#) [S70KS1282GABHB020](#) [S70KL1282DPBHI020](#) [SQR-SD4N8G3K2SNBCB](#) [IS66WVO32M8DALL-200BLI-TR](#) [IS66WVO32M8DBLL-133BLI-TR](#) [IS46TR16K01S2AL-125KBLA2](#) [IS46QR16512A-083TBLA2](#) [MT48LC64M8A2P-75:C TR](#) [AS4C4M32SA-6TINTR](#) [MT40A2G8JC-062E IT:E](#) [MT53E1G32D2FW-046 AAT:B TR](#) [MT42L64M32D2HE-18 IT:D](#) [MT53E512M64D2RR-046 WT:B](#) [MT40A1G16KD-062E IT:E](#) [IS66WVH16M8DBLL-100B1LI](#) [IS66WVH16M8DALL-166B1LI](#) [S70KL1282GABHV020](#) [MT53E1G32D2FW-046 IT:B](#) [MT40A1G16TB-062E IT:F](#) [NT5CB256M16ER-FL](#) [NT5CB128M16IP-EK](#) [NT5CC512M8EN-EK](#) [K4F8E304HB-MGCJ](#) [K4B2G1646F-BCMA](#) [K4RAH165VB-BCQK](#) [K4B4G1646E-BMMA](#)