



**ITT**

### Customer Support Locations

#### ASIA

Tuopandun Industrial Area, Jinda Cheng,  
Xiner Village, Shajing Town,  
Baoan District, Shenzhen City,  
Guangdong, China 518125  
Tel: +86 755 2726 7238  
Fax: +86 755 2726 7515

#### GERMANY

Cannonstrasse 1  
Weinstadt, 71364  
Tel: +49.7151.699.0  
Fax: +49.7151.699.217

#### ITALY

Corso Europa 41/43  
Lainate (MI),  
Italy 20020  
Tel: +39.02938721  
Fax: +39.0293872300

#### UK

Jays Close, Viabes Estate  
Basingstoke, Hants, RG22 4BA  
Tel: +44.1256.311200  
Fax: +44.1256.323356

#### USA

100 New Wood Road  
Watertown, CT 06796  
Tel: 860.945.0206  
Toll Free: 800.683.7666  
Fax: 860.645.0303

[www.ittcannon.com](http://www.ittcannon.com)



Electronic Components

## Cannon 50 Ohm RF Connectors

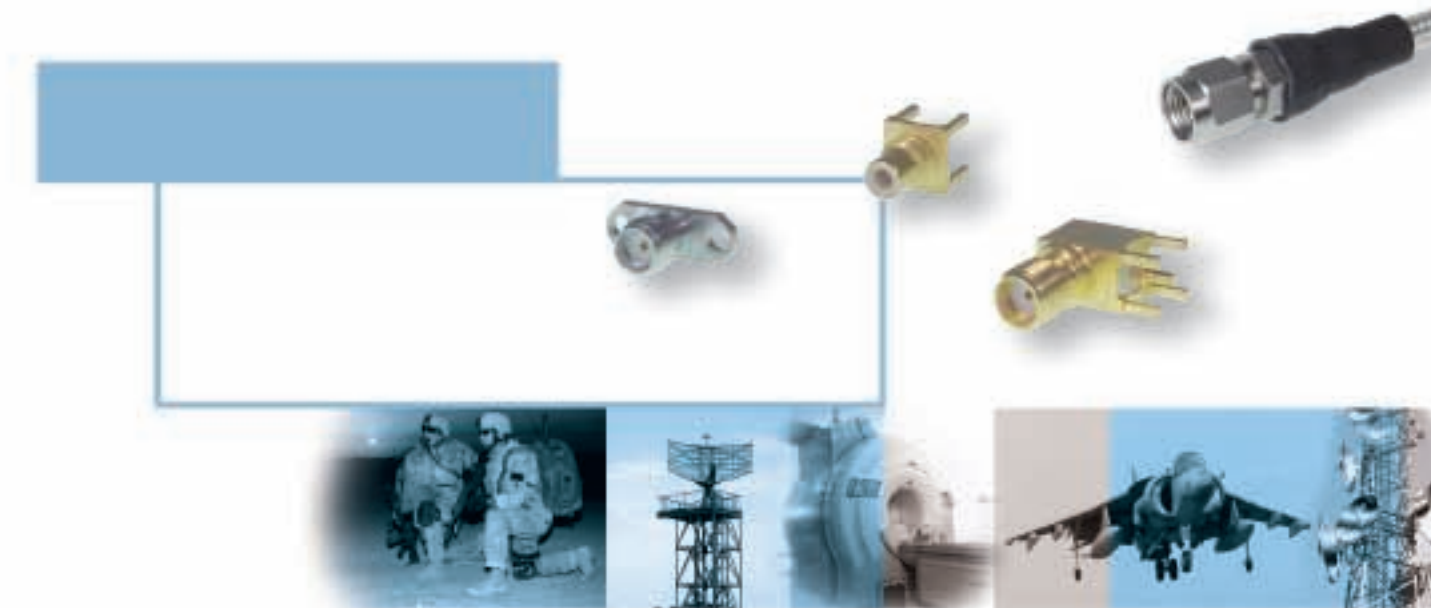

*Engineered for life*

©2007 ITT Corporation. "Engineered for life" and "Cannon" are registered trademarks of ITT Corporation. Specification and other data are based on information available at the time of printing, and are subject to change without notice.

50 RF Apr-07

## Over 90 year history ...

ITT Electronic Components is an innovative and dynamic company with the in-depth experience of a 90 plus year industry leader. We are part of ITT Corporation, a multi-disciplined, multi-national company engaged in the design and manufacture of electronic components, defense products and fluid handling controls.

ITT operates globally and is active in many diverse markets including telecom, carrier networks, wireless, medical electronics, instrumentation, military, microwave components, information systems and radar. ITT is an approved manufacturer to ISO 9001 and ISO 14001.



## Broad range of Cannon connectors and cable assemblies

In addition to our 50 Ohm RF product line, we also offer a range of 75 Ohm connectors including Type 43 (SMZ), 1.0/2.3, 1.6/5.6 and BNC.

### Cannon CoSMID™ connectors

CoSMID™ (Coax Surface Mount MID) 75 ohm connectors use molded interconnect device technology – a process which allows the selective metallization of 3D plastic shapes. Two, three or four coaxial connector lines can be integrated into a single surface mountable module. The modular design means that designers can incorporate more coax lines on a card edge than ever before.

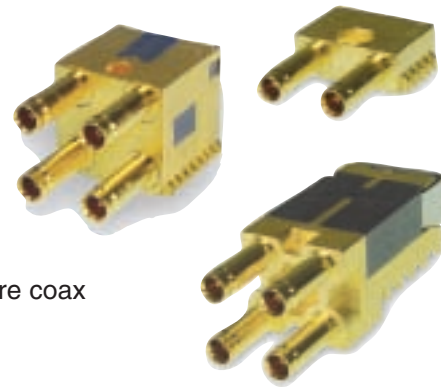

### QT - Quick Termination Connectors

Quick Termination connectors have the special QT contact pre-assembled into the main connector assembly, which eliminates the process of crimping or soldering onto the center conductor of a cable. The center conductor is terminated to the inner contact within the connector assembly, by activating the QT (patented) mechanism using the simple plastic tool provided. The assembly is completed in 4 simple steps.

1. Strip cable using standard tooling.
2. Assemble connector on to cable.
3. Press insulator into connector body.
4. Crimp the ferrule using standard hex crimp tool to complete the termination.

The QT principle may be applied to 50 Ohm products also. Contact our Customer Service group for more information.

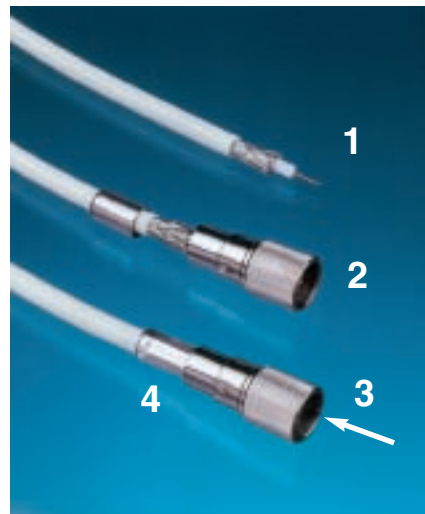

CoSMID is a trademark of ITT Corporation.  
CANNON, ENGINEERED FOR LIFE, the ITT "Engineered Blocks" symbol and the composite ITT logo are registered trademarks of ITT Corporation © 2007



ITT's Electronic Components business ([www.ittcannon.com](http://www.ittcannon.com)) is an international supplier of connectors, interconnects, cable assemblies, I/O card kits and smart card systems. As a worldwide leader in connector technology for nearly a century, ITT offers one of the industry's broadest product offerings, manufacturing capability worldwide, fast time to market, high volume/high yield capacity, robust design and Value-Based Product Development and an extensive sales and customer support network.



### Circular/Filter/Hermetic Connectors

As a world leader in circular, filter and hermetic connectors, ITT can leverage its design and manufacturing expertise to fit virtually any application. Our expertise includes fast positive mating for a wide range of military applications, as well as numerous sizes and contact configuration for various harsh environments. ITT can also meet numerous specs, including NATO and MIL standards.

[www.ittcannon.com/circulars](http://www.ittcannon.com/circulars) • [www.ittcannon.com/filter](http://www.ittcannon.com/filter) • [www.ittcannon.com/hermetics](http://www.ittcannon.com/hermetics)



### D-Subminiature Connectors

Cannon invented D-sub connectors in 1952. Our family of D-Subs now includes combinations of signal, power and RF, as well as severe service sealed connectors. Cannon D-Subs are available with an extensive line of backshells and accessories and are one of the most economical shielded connector solutions available. Qualified to the MIL-DTL-24308 specification.

[www.ittcannon.com/dsubs](http://www.ittcannon.com/dsubs)



### Fiber Optic Connectors

Cannon fiber optic solutions provide an excellent performance/cost value. Performance can be tailored to the end system, and our use of superior materials and bonding agents provides highly effective solutions. Our wide variety of products includes fiber optic hybrid contacts, multi-channel, rack and panel, and hi-rel assemblies, including MIL and ARINC standard solutions.

[www.ittcannon.com/fiberoptics](http://www.ittcannon.com/fiberoptics)



### Microminiature Connectors

Cannon microminiature connectors offer high performance and reliability with exceptional versatility. Available in rectangular, circular and strip configurations for countless applications, many of our connectors meet or exceed applicable requirements of the MIL-DTL-83513 specification.

[www.ittcannon.com/micro](http://www.ittcannon.com/micro)



### RF Connectors

Whether you need 50 Ohm or 75 Ohm RF connectors or 26 GHz high performance RF cable assemblies, or connector types including coax, BNC, SMA, SSMB or SBM, ITT has the solution. A leading supplier to numerous communications manufacturers for military and commercial OEMs, ITT offers unmatched expertise in RF connectors.

[www.ittcannon.com/rf](http://www.ittcannon.com/rf)



## TABLE OF CONTENTS

| Description                 | Page |
|-----------------------------|------|
| Selection Guide             | 4    |
| SMA (Precision) Connectors  | 6    |
| SMA (Commercial) Connectors | 13   |
| SMB Connectors              | 19   |
| SMC Connectors              | 24   |
| SSMB Connectors             | 27   |
| SSMC Connectors             | 31   |
| Coaxial Terminators         | 33   |
| Between Series Adaptors     | 35   |
| Sealflex 2™ Assemblies      | 37   |
| Mounting Information        | 40   |
| Assembly Instructions       | 41   |
| Tooling                     | 58   |
| Glossary of Terms           | 60   |
| Part Number Index           | 61   |
| Product Safety Information  | 62   |

### CABLE ASSEMBLY SERVICE

Cannon has a precision cable assembly facility for the manufacture and testing of a wide range of cable / connector assemblies. By using Cannon's considerable expertise in this field, the customer is relieved of expensive training, tooling and reject problems. This invariably offers economic and logistical advantages when compared to user assembly.

Flexible, semi-rigid and Sealflex 2 RF and microwave coaxial cable assemblies for DC to 40 GHz are manufactured to the most complex customer designs and exacting mechanical and electrical tolerances. A full range of MIL-C-17G proprietary flexible and semi-rigid cables are used as well as the Sealflex 2 fully flexible, low loss microwave cable. With computerized semi-rigid cable forming and Vector Network Analyzer test equipment cable assemblies are manufactured for quality conscious customers the world over. Our skills, experience and 100% electrical testing allow us to build products that meet or exceed expectations.

### 75 OHM CONNECTORS

Cannon also offer a wide selection of 75 Ohm connectors for switching and transmission in telecom applications. These include the popular Type 43 (SMZ), 1.0/2.3, 1.6/5.6 and BNC connector ranges incorporating the CoSMID™ surface mountable modular technology and the (patented) 'QT' quick termination designs. The CoSMID modular design allows designers to incorporate more coax lines on a card edge than ever before and the QT assembly eliminates the process of crimping or soldering onto the centre conductor of the cable.

### FAKRA CONNECTORS

In addition to the range of SMB connectors we also offer FAKRA connectors for automotive applications.

For more details on any of the products listed above, please visit [www.ittcannon.com](http://www.ittcannon.com).

**CONNECTOR / CABLE SELECTION GUIDE**

Given here are details of all popular cables with which the connectors in this publication may be used.

Cable numbers suitable for use with all cable mounting connectors are given opposite the connector part numbers in the series chosen.

| Cable Number | Impedance (ohms) | Diameter of Jacket | Diameter of Outer Conductor (Max) | Diameter of Dielectric (Max) | Diameter of Center Conductor (Nom) |
|--------------|------------------|--------------------|-----------------------------------|------------------------------|------------------------------------|
| BT3002       | 75               | 3,55 (.140)        | 2,85 (.112)                       | 1,95 (.077)                  | 0,31 (.012)                        |
| RD179*       | 75               | 3,07 (.121)        | 2,69 (.106)                       | 1,68 (.066)                  | 0,30 (.012)                        |
| RD316*       | 50               | 3,00 (.118)        | 2,79 (.101)                       | 1,60 (.063)                  | 0,51 (.020)                        |
| RG174/U      | 50               | 2,67 (.105)        | 2,24 (.088)                       | 1,60 (.063)                  | 0,48 (.019)                        |
| RG178/U      | 50               | 1,91 (.075)        | 1,37 (.054)                       | 0,91 (.036)                  | 0,30 (.012)                        |
| RG179/U      | 75               | 2,67 (.105)        | 2,13 (.084)                       | 1,68 (.066)                  | 0,30 (.012)                        |
| RG187/U      | 75               | 2,80 (.110)        | 2,13 (.084)                       | 1,68 (.066)                  | 0,30 (.012)                        |
| RG188/U      | 50               | 2,80 (.110)        | 2,06 (.081)                       | 1,60 (.063)                  | 0,51 (.020)                        |
| RG196/U      | 50               | 2,04 (.080)        | 1,37 (.054)                       | 0,91 (.036)                  | 0,30 (.012)                        |
| RG316/U      | 50               | 2,60 (.102)        | 2,06 (.081)                       | 1,60 (.063)                  | 0,51 (.020)                        |
| RG402/U      | 50               | -                  | 3,61 (.142)                       | 3,05 (.120)                  | 0,91 (.036)                        |
| RG405/U      | 50               | -                  | 2,18 (.086)                       | 1,70 (.067)                  | 0,51 (.020)                        |
| TZC75024     | 75               | 3,55 (.140)        | 3,01 (.119)                       | 1,95 (.077)                  | 0,31 (.012)                        |
| RG141        | 50               | 4,95 (.195)        | 3,71 (.146)                       | 3,07 (.121)                  | 0,99 (.039)                        |
| RG142        | 50               | 5,08 (.200)        | 4,34 (.171)                       | 3,07 (.121)                  | 0,99 (.039)                        |

\*Double shielded

**PART NUMBER GUIDE**



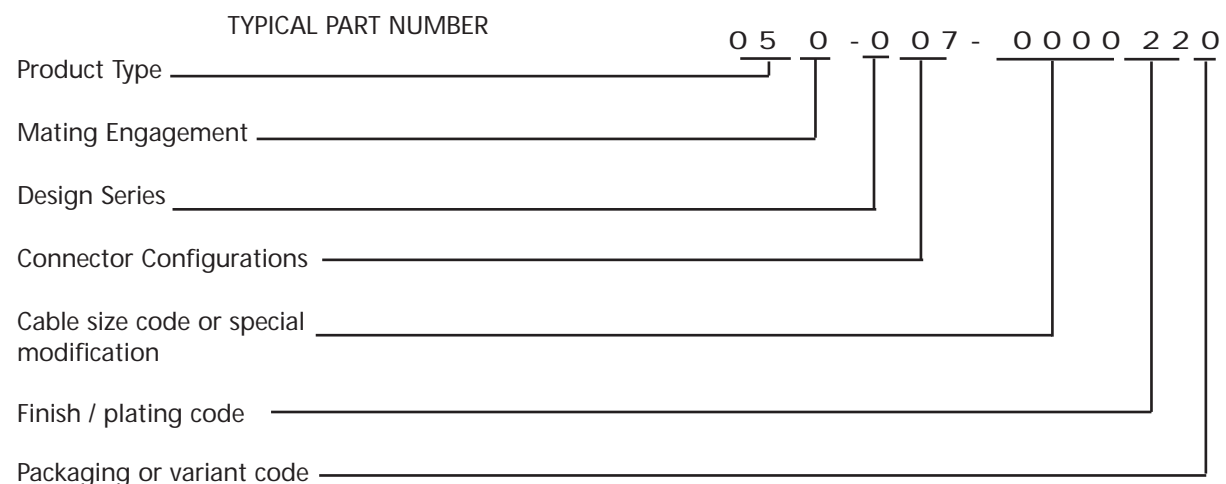



This table shows how the part numbers for coaxial connectors are constructed.





Dimensions shown in mm (inch)  
Specifications and dimensions subject to change

www.ittcannon.com

**QUICK REFERENCE SELECTION GUIDE**

|               |   |   |   |  |   |   |
|---------------|---|---|---|--|---|---|
|               |  |  |  |  |  |  |
| Series        | <b>SMA Precision</b>  | <b>SMA Commercial</b>   | <b>SMB</b>  | <b>SMC</b>   | <b>SSMB</b>   | <b>SSMC</b>   |
| Description   | Coaxial connector for rugged environments   | Robust economical coaxial connectors  | Rapid connect /disconnect coaxial connectors                                      | Vibration resistant coaxial connectors   | Microminiature rapid connect / disconnect coaxial connectors                        | Microminiature rapid connect / disconnect coaxial connectors                        |
| Frequency     | DC - 18 GHz   | DC - 18 GHz   | DC - 4 GHz  | DC - 12.4 GHz  | DC - 4 GHz  | DC - 4 GHz  |
| Impedance     | 50Ω   | 50Ω   | 50Ω   | 50Ω  | 50Ω   | 50Ω   |
| Cable Type    | Flexible/ semi-rigid  | Flexible/ semi-rigid  | Flexible  | Flexible   | Flexible  | Flexible  |
| Coupling      | Screw   | Screw   | Snap-on   | Screw  | Snap-on   | Screw   |
| Body Material | Stainless steel or beryllium copper   | Brass   | Brass   | Brass  | Brass   | Brass   |
| Body Finish   | Gold or passivated  | Gold over nickel  | Gold or nickel  | Gold or nickel   | Gold or nickel  | Gold or nickel  |
| Page Number   | 6   | 13  | 19  | 24   | 27  | 31  |

|               |   |   |   |
|---------------|---|---|---|
|               |  |  |  |
| Series        | <b>Coaxial Terminators</b>  | <b>Between Series Adaptor</b>   | <b>SEALFLEX 2™</b>  |
| Description   | Provide permanent coaxial connections to printed circuit boards                     | High efficiency transitions between various coaxial connector series                | High performance flexible microwave cable assemblies                                |
| Frequency     | DC - 4 GHz  | DC - 18 GHz   | DC - 18 GHz   |
| Impedance     | N/A   | 50Ω   | 50Ω   |
| Cable Type    | Flexible  | N/A   | Flexible  |
| Coupling      | N/A   | Various   | Screw   |
| Body Material | Copper alloy  | Stainless steel or brass  | Stainless steel (connectors)  |
| Body Finish   | Electroplated tin   | Gold or passivated  | Passivated (connectors)   |
| Page Number   | 33  | 35  | 37  |

Dimensions shown in mm (inch)  
 Specifications and dimensions subject to change

[www.ittcannon.com](http://www.ittcannon.com)





**Key Features**

- Military grade
- Rugged stainless steel design
- Intermateable with all SMA's to Mil-C-39012
- Frequency range DC to 18 GHz

Cannon's precision SMA connectors feature the MIL-C-39012 Series SMA interface and envelope configuration. They can be mated with all connectors meeting the MIL specification dimensions. Designed for use with a variety of subminiature coaxial cables, superior results are obtained from DC to 18 GHz when used with semi-rigid cables and from DC to 12.4 GHz with flexible cable. These connectors are manufactured with beryllium copper bodies which are gold plated or stainless steel bodies which can be supplied with either a gold plated or passivated finish.

Cannon also offers a range of commercial SMA brass bodied connectors. For further details, please see page 13.

**MATING INTERFACES**

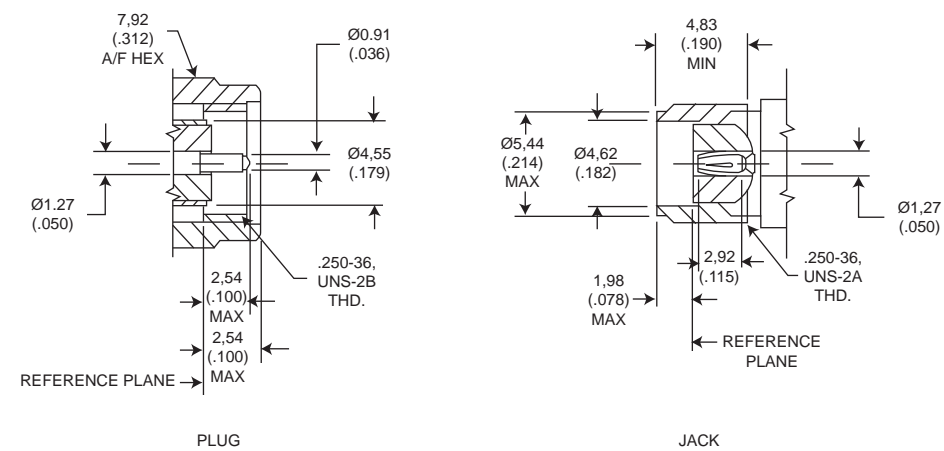

Dimensions shown in mm (inch)  
Specifications and dimensions subject to change

www.ittcannon.com

**SPECIFICATIONS**

|  |  |  |             |             |
|--|--|--|-------------|-------------|
| ELECTRICAL   | Impedance  | 50Ω nominal  |             |             |
|  | Frequency Range  | 0 to 18.0 GHz  |             |             |
|  | Voltage Rating   | Connectors for RG178/U series cable: At Sea Level=170 Vrms. At 21km (70k feet) = 45 Vrms<br>Connectors for RG316/U series cable: At Sea Level = 250 Vrms. At 21km (70k feet) = 65 Vrms<br>Connectors for RG142/U series cable: At Sea Level = 335 Vrms. At 21km (70k feet) = 85 Vrms |             |             |
|  | Insulation Resistance  | 5000 MΩ minimum  |             |             |
|  | Contact resistance   | Center Contact = 3.0 m Ω maximum initial. 4.0 m Ω maximum after environment<br>Outer Contact = 2.0 m Ω maximum initial. 2.0 m Ω maximum after environment<br>Braid to Body = 0.5 m Ω maximum   |             |             |
|  | Contact Current Rating   | 2.0 A dc maximum   |             |             |
|  | Insertion Loss   | 0.06 x $\sqrt{\text{freq. GHz}}$ tested at 6 GHz   |             |             |
|  | RF Leakage   | -60 dB minimum @ 2 - 3 GHz   |             |             |
|  | Voltage Standing Wave Ratio (VSWR)<br>To 18 GHz or 80% of upper cut-off frequency of the cable, whichever is lower.<br>Applicable to 50Ω cables only.(F = GHz) | Connector Configuration  |             |             |
|  |  | Cable group  | Straight    | Right Angle |
| RG178/U braided  |  | 1.20 + .025F   | 1.20 + .03F |             |
| RG316/U braided  |  | 1.15 + .02F  | 1.15 + .03F |             |
| Dielectric Withstanding Voltage (DWV)<br>Corona Level                            | Connectors used with RG316/U series cable = 750 Vrms @ Sea Level   |  |             |             |
|  | Connectors used with RG316/U series cable = 190 V @ 21km (70k feet) minimum  |  |             |             |
|  | SMA per MIL-C-39012, Series SMA  |  |             |             |
| MECHANICAL   | Engagement Design  | Torque: 0.23 Nm (2 in. lbs.) maximum   |             |             |
|  | Engagement Forces  | 0.03 Nm (4 in. ozs.) minimum. (For captivated contacts)  |             |             |
|  | Contact Torque   | 0.8 Nm to 1.1 Nm (7 to 10 in. lbs.)  |             |             |
|  | Mating Torque  | 1.4 Nm to 1.7 Nm (12 to 15 in. lbs.) minimum   |             |             |
|  | Locknut Torque   | 267 N (60 lbs.) minimum  |             |             |
|  | Coupling Nut Retention   | Body & Body Components: Non-magnetic stainless steel or beryllium copper.<br>Female Contacts: Beryllium copper. Insulators: PTFE. Crimp Ferrule: Annealed copper alloy.<br>Gaskets: Silicone rubber  |             |             |
|  | Materials  | Center Contacts: Gold plated. Other Metal Parts: Gold plated or passivated (as specified) to meet the finish and corrosion requirements of MIL-C-39012   |             |             |
| ENVIRONMENTAL  | Temperature Rating   | -65° C to 165° C   |             |             |
|  | Corrosion (salt spray)   | MIL-STD-202, Method 101, test condition B, 5% salt solution  |             |             |
|  | Vibration, High Frequency  | MIL-STD-202, Method 204, test condition D (20 G's)   |             |             |
|  | Shock  | MIL-STD-202, Method 213, test condition I (100 G's)  |             |             |
|  | Thermal Shock  | MIL-STD-202, Method 107, test condition B  |             |             |
|  | Moisture Resistance  | MIL-STD-202, Method 106. No measurements at high humidity. Insulation resistance shall be 200 M Ω minimum within 5 minutes after removal from humidity.  |             |             |
| GENERAL  | Connector Durability   | 500 matings minimum  |             |             |
|  | Contact Captivation  | Unless otherwise specified, all connectors feature captivated contacts. When captivated the contacts will withstand 26.7 N (6 lbs.) minimum axial force.   |             |             |
|  | Cable Retention  | When properly assembled to the compatible single braided coaxial cable, the retention is equal to the breaking strength of the cable.  |             |             |
| Body Plating Options   |  |  |             |             |
| The following part number suffices can be specified for Precision SMA Connectors |  |  |             |             |
| ..... 310 gold body, gold coupling nut   |  |  |             |             |
| ..... 890 passivated body & coupling nut   |  |  |             |             |
| except <u>Direct Solder Types</u> : gold body, passivated coupling nuts          |  |  |             |             |

Dimensions shown in mm (inch)  
Specifications and dimensions subject to change

www.ittcannon.com



**CRIMP TYPE CABLE CONNECTORS FOR FLEXIBLE CABLE**

Straight Plug, Non-Captive Contact

| Part Number         | Cable Numbers  |
|---------------------|----------------|
| 050 - 622 - 9188890 | RG174/U, 316/U |
| 050 - 622 - 9875890 | RD316          |

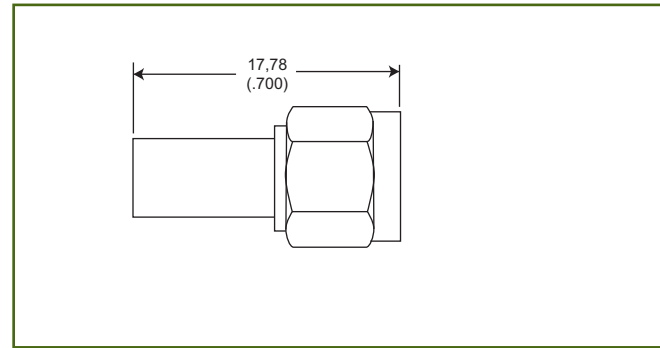

Assembly Instructions AI-102 (Page 43)

Straight Plug, Captive Contact

| Part Number         | Cable Numbers  |
|---------------------|----------------|
| A50 - 624 - 9188890 | RG174/U, 316/U |
| A50 - 624 - 9875890 | RD316          |

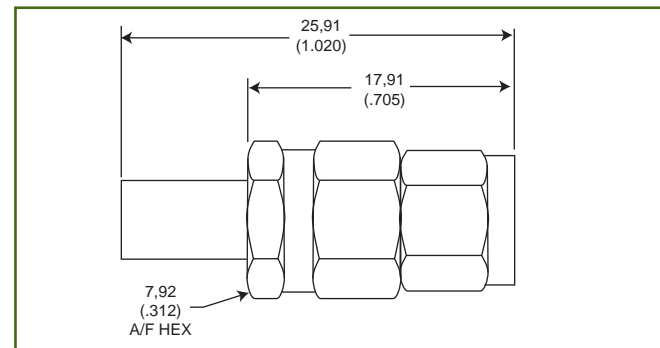

Assembly Instructions AI-703 (Page 51)

Right Angle Plug, Captive Contact

| Part Number         | Cable Numbers  |
|---------------------|----------------|
| 050 - 628 - 9188890 | RG174/U, 316/U |
| 050 - 628 - 9875890 | RD316          |

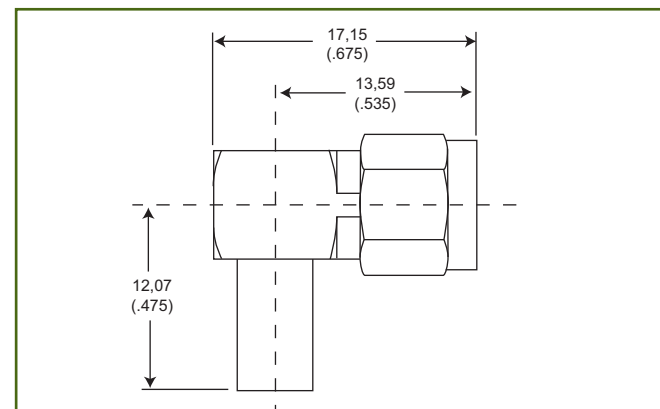

Assembly Instructions AI-90 (Page 41)

Bulkhead Jack, Captive Contact

| Part Number         | Cable Numbers  |
|---------------------|----------------|
| 050 - 627 - 9188890 | RG174/U, 316/U |
| 050 - 627 - 9875890 | RD316          |

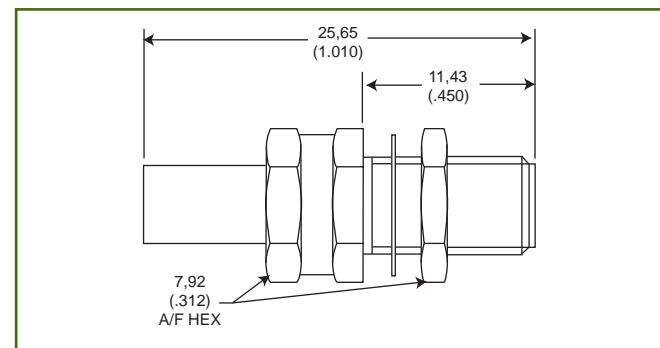

Mounting Plan W (Page 40)  
Assembly Instructions AI-227 (Page 46)

The surface finish on these products is passivated stainless steel. For gold plated versions change last three digits of the the part number from 890 to 310.

Dimensions shown in mm (inch)  
Specifications and dimensions subject to change

www.ittcannon.com





**DIRECT SOLDER TYPE CABLE CONNECTORS FOR SEMI-RIGID CABLE**

Straight Plug without Center Contact\*

| Part Number        | Cable Numbers |
|--------------------|---------------|
| 055 - 607- 2003890 | RG402/U       |

\*Center conductor of cable is used as contact

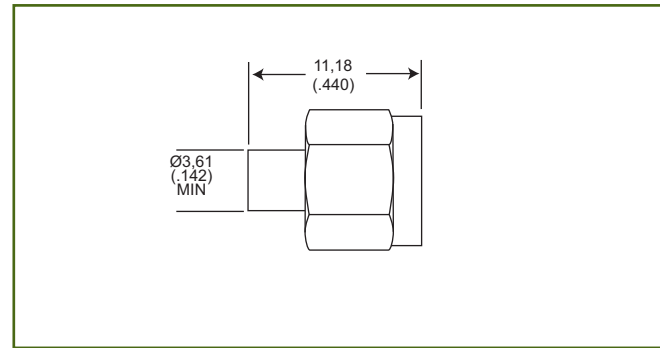

Assembly Instructions AI-302 (Page 48)

Straight Plug with Center Contact

| Part Number         | Cable Numbers | A           |
|---------------------|---------------|-------------|
| 055 - 607- 9172890  | RG405/U       | 2,20 (.088) |
| 055 - 607 - 9173890 | RG402/U       | 3,60 (.142) |

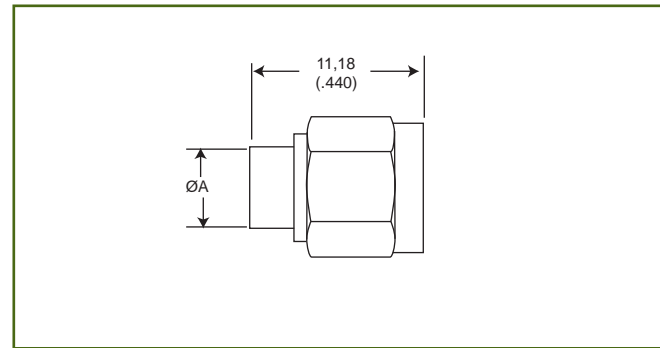

Assembly Instructions AI-252 (Page 47)

Right Angle Plug

| Part Number        | Cable Numbers | A           |
|--------------------|---------------|-------------|
| 055 - 611- 3702890 | RG405/U       | 2,20 (.088) |
| 055 - 611- 3703890 | RG402/U       | 3,60 (.142) |

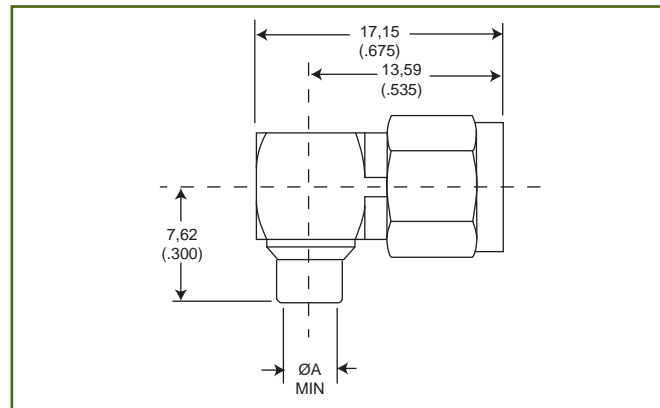

Assembly Instructions AI-98 (Page 42)

The surface finish on these products is passivated stainless steel. For gold plated versions change last three digits of the the part number from 890 to 310.

**FLANGE MOUNT RECEPTACLES**

Straight Jack, Stub Contact, Extended Dielectric

| Part Numbers        |                     |
|---------------------|---------------------|
| Square Flange       | Narrow Flange       |
| 050 - 645 - 9009890 | 050 - 645 - 4540890 |

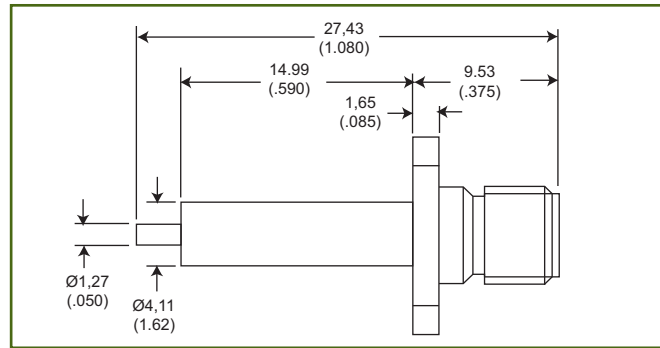

Straight Jack, Solder Pot Contact, Flush Dielectric

| Part Numbers        |                          |
|---------------------|--------------------------|
| Square Flange       | Narrow Flange            |
| 050 - 645 - 9019890 | Contact Customer Service |

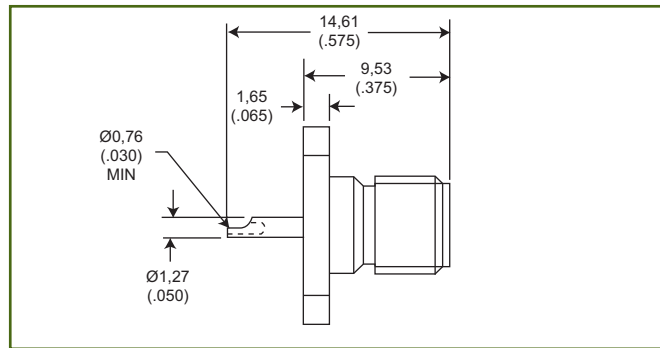

Straight Jack, Tab Contact, Flush Dielectric

| Part Numbers        |                     |
|---------------------|---------------------|
| Square Flange       | Narrow Flange       |
| 050 - 645 - 4575890 | 050 - 645 - 4528890 |

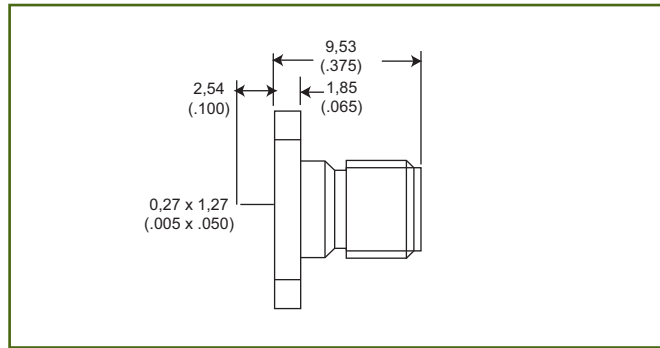

Flange Dimensions for Flange Mount Receptacles and Panel Jacks

ALL FLANGE MOUNT RECEPTACLES HAVE CAPTIVATED CONTACTS

The surface finish on these products is passivated stainless steel. For gold plated versions change last three digits of the the part number from 890 to 310.

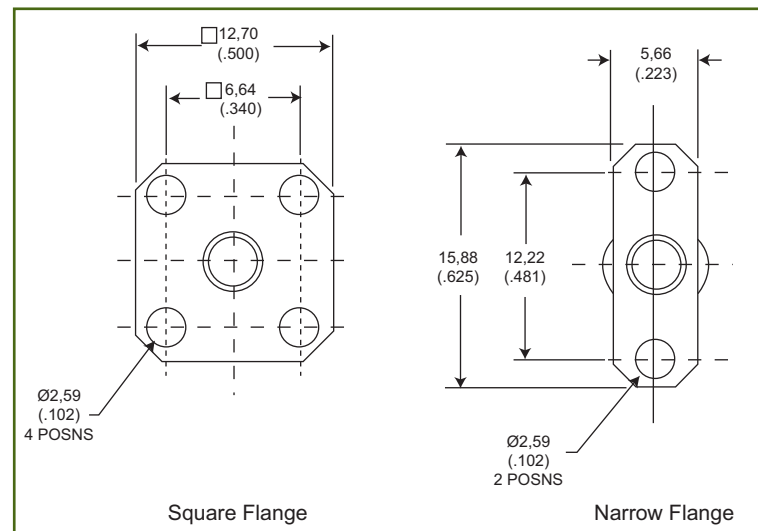

Dimensions shown in mm (inch)  
Specifications and dimensions subject to change

www.ittcannon.com



**PRINTED CIRCUIT RECEPTACLES**

Straight Jack

Part Number

050 - 651 - 0000310

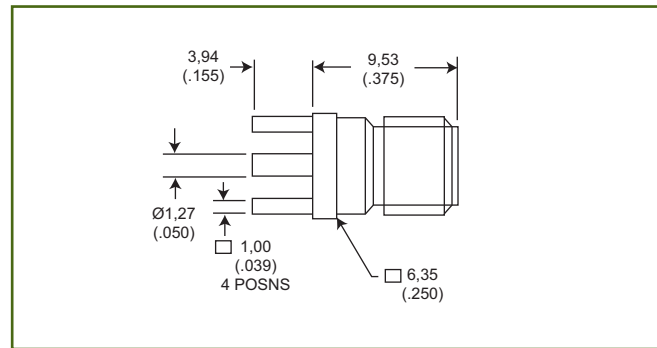

Mounting Plan D (Page 40)

Right Angle Jack

Part Number

050 - 653 - 0000310

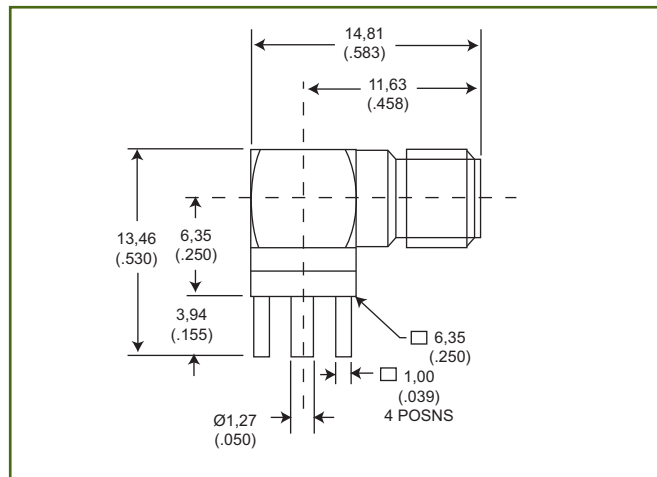

Mounting Plan D (Page 40)

**IN-SERIES ADAPTORS**

Plug to Plug Adaptor, Straight

|                     |
|---------------------|
| Part Number         |
| 050 - 673 - 0000890 |

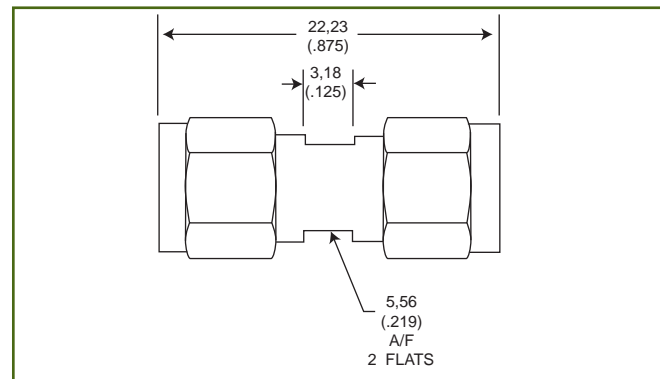

Plug to Jack Adaptor, Straight

|                     |
|---------------------|
| Part Number         |
| 050 - 674 - 0000890 |

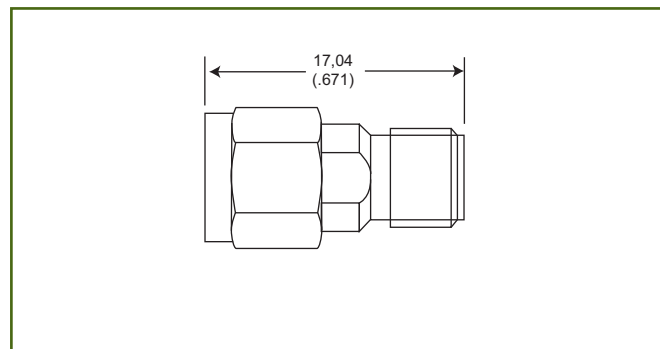

Jack to Jack Adaptor, Bulk Head Mount, Straight

|                     |
|---------------------|
| Part Number         |
| 050 - 675 - 0000890 |

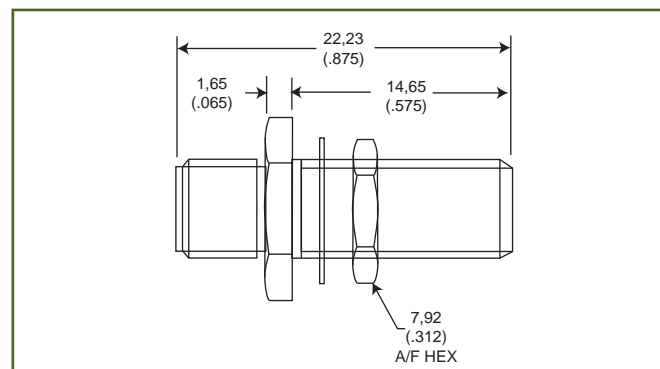

Mounting Plan W (Page 40)

Plug to Jack Adaptor, Right Angle

|                     |
|---------------------|
| Part Number         |
| 050 - 678 - 0000890 |

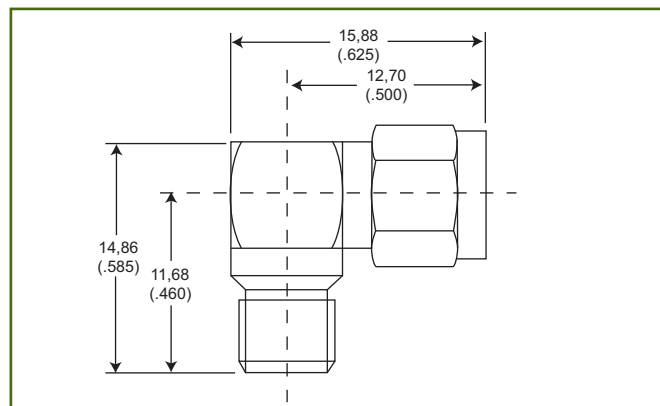

The surface finish on these products is passivated stainless steel. For gold plated versions change last three digits of the the part number from 890 to 310.



Dimensions shown in mm (inch)  
Specifications and dimensions subject to change

[www.ittcannon.com](http://www.ittcannon.com)

Cannon's Commercial SMA connectors are subminiature devices that provide repeatable electrical performance through the frequency range DC to 18.0 GHz. These 50 ohm connectors offer minimum attenuation with low reflection which makes them extremely popular in the RF and microwave industry. The MIL-C-39012 series SMA interface ensures they can be mated with all connectors meeting the MIL specification dimensions. They are designed for use with a variety of subminiature coaxial cables. This includes semi-rigid and hand formable cables as well as the popular RG series of flexible cable and commercial cables meeting these dimensions.

These SMA connectors feature stand-off legs on the PCB mount designs to enhance soldering, cleaning and inspection. The straight plugs feature crimp / solder contacts for speed of assembly and high performance. SMA connectors are found in many diverse applications including amplifiers, dividers, filters and attenuators.

The standard units are supplied in gold plate. Nickel plated versions are available on request.



**Key Features**

- Crimp /solder contacts on straight plugs and bulkhead jacks
- Stand-off legs on PCB mounts
- Intermateable with all SMAs to MIL-C-39012

**MATING INTERFACES**

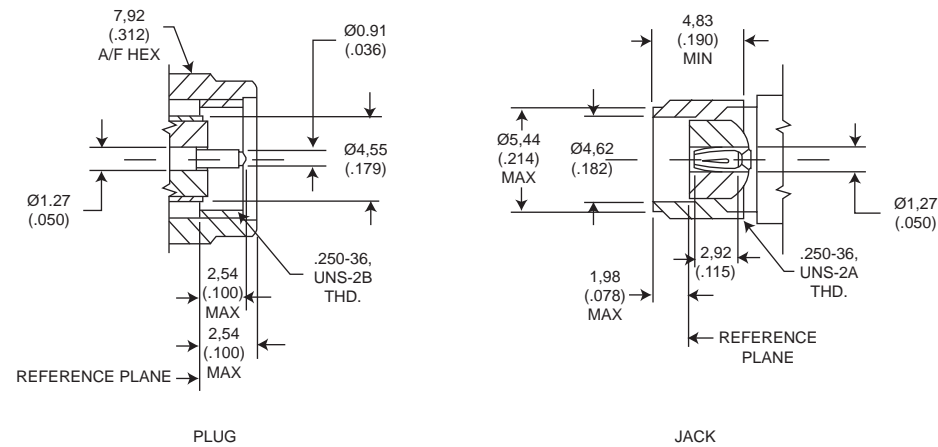

**SPECIFICATIONS**

|                                    |   |  |   |  |
|------------------------------------|---|--|---|--|
| ELECTRICAL                         | Impedance                                 | 50Ω  |   |  |
|                                    | Frequency Range                           | 0 to 18.0 GHz                                      |   |  |
|                                    |   | for RG-402 & RG-405 semi-rigid cable - 0 to 18 GHz |   |  |
|                                    |   |  | for flexible cable - 0 to the maximum frequency of the cable per MIL-C-17 |  |
|                                    | Voltage Rating                            | RG402 (0.141" OD.)                                 | 550 volts rms maximum   |  |
|                                    |   | RG405 (0.085" OD.)                                 | 335 volts rms maximum   |  |
|                                    |   | RG58, 141, 142, 223                                | 550 volts rms maximum   |  |
|                                    |   | RG174, 188, 316                                    | 335 volts rms maximum   |  |
|                                    | Insulation Resistance                     | 5000 MΩ minimum                                    |   |  |
|                                    | Contact Resistance                        | Center Contact = 5.0 mΩ maximum                    |   |  |
|                                    |   | Outer Contact = 1.0 mΩ maximum                     |   |  |
|                                    | Insertion Loss                            | 0.04 dB maximum x $\sqrt{f}$ GHz (straight)        |   |  |
|                                    |   | 0.06 dB maximum x $\sqrt{f}$ GHz (right angle)     |   |  |
| RF Leakage                         | -(90-f GHz) dB minimum                    |  |   |  |
| Voltage Standing Wave Ratio (VSWR) | 1.05+0.15 x f GHz maximum (straight)      |  |   |  |
|                                    | 1.15+0.15 x f GHz maximum (right angle)   |  |   |  |
|                                    | RG402 (0.141" OD)                         | 1.05+0.005 x f GHz maximum                         |   |  |
|                                    | RG405 (0.085" OD)                         | 1.05+0.005 x f GHz maximum                         |   |  |
|                                    | RG58, 141, 142, 223                       | 1.10+0.01 x f GHz maximum (straight)               |   |  |
|                                    |   | 1.15+0.02 x f GHz maximum (right angle)            |   |  |
|                                    | RG174, 188, 316                           | 1.15+0.01 x f GHz maximum (straight)               |   |  |
| Dielectric Withstanding Voltage    | RG402 (0.141" OD)                         | 1000 volts rms maximum                             |   |  |
|                                    | RG405 (0.085" OD)                         | 750 volts rms maximum                              |   |  |
|                                    | RG58, 141, 142, 223                       | 1000 volts rms maximum                             |   |  |
|                                    | RG174, 188, 316                           | 750 volts rms maximum                              |   |  |
| MECHANICAL & ENVIRONMENTAL         |   |  |   |  |
| Mating                             | 1/4" - 36 threaded coupling               |  |   |  |
| Durability                         | 500 matings                               |  |   |  |
| Coupling Nut Retention             | Minimum 60 lbs                            |  |   |  |
| Recommended Nut Mating Torque      | 8 inch-pounds                             |  |   |  |
| Cable Retention                    | RG58, 141, 142, 223 40 lbs minimum        |  |   |  |
|                                    | RG174, 188, 316                           | 20 lbs minimum                                     |   |  |
| Temperature Range                  | -65°C to 165°C                            |  |   |  |
| Vibration                          | MIL-STD-202 Method 204 test condition D   |  |   |  |
| Salt Spray                         | MIL-STD-202, Method 101, test condition B |  |   |  |
| Temperature Cycling                | MIL-STD-202, Method 102 test condition C  |  |   |  |
| MATERIAL                           | Connector Body                            | Material   | Plating   |  |
|                                    |   | Brass  | Gold or nickel  |  |
|                                    | Center Contact                            | Male: Brass  | Gold over nickel  |  |
|                                    |   | Female: beryllium-copper                           | Gold over nickel  |  |
|                                    | Insulation                                | Teflon   | None  |  |
|                                    | Gasket                                    | Silicone   | None  |  |
| Crimp Ferrule                      | Annealed Copper                           | Same as body                                       |   |  |

Dimensions shown in mm (inch)  
Specifications and dimensions subject to change

www.ittcannon.com



**CRIMP ATTACHMENTS FOR FLEXIBLE CABLE**

Straight Crimp Plug

| Part Number         | Cable Numbers |
|---------------------|---------------|
| F50 - E22 - 9141000 | RG141         |
| F50 - E22 - 9142000 | RG142         |

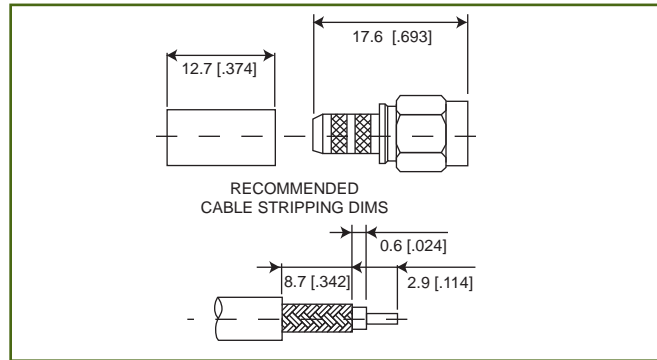

Assembly Instructions CSMA 1 (Page 54)

Straight Crimp Plug

| Part Number         | Cable Numbers |
|---------------------|---------------|
| F50 - E22- 9188000  | RG316         |
| F50 - E22 - 9875000 | RD316         |

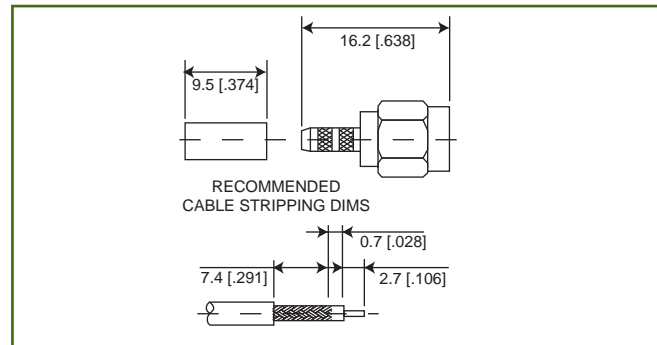

Assembly Instructions CSMA 1 (Page 54)

Right Angle Crimp Plug

| Part Number         | Cable Numbers |
|---------------------|---------------|
| F50 - E28 - 9141000 | RG141         |
| F50 - E28 - 9142000 | RG142         |

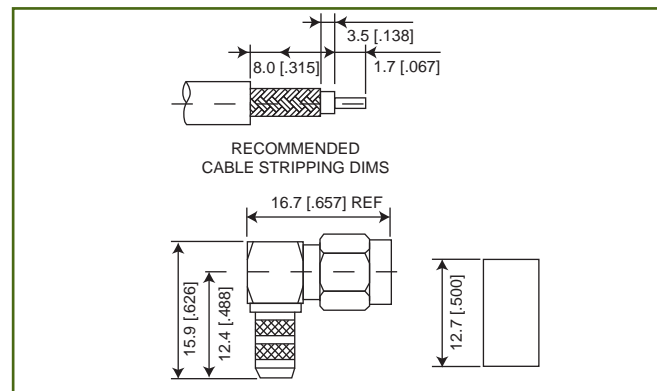

Assembly Instructions CSMA 2 (Page 54)

Right Angle Crimp Plug

| Part Number         | Cable Numbers |
|---------------------|---------------|
| F50 - E28 - 9188890 | RG316         |
| F50 - E28 - 9875000 | RD316         |

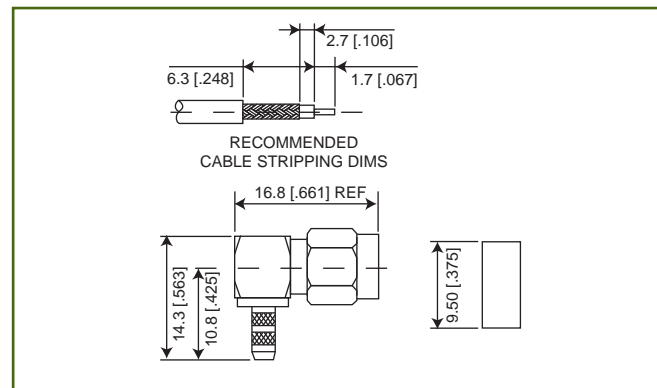

Assembly Instructions CSMA 2 (Page 54)

**CRIMP ATTACHMENTS FOR FLEXIBLE CABLE**

Bulkhead Crimp Jack

| Part Number         | Cable Numbers |
|---------------------|---------------|
| F50 - E27 - 9188000 | RG316         |
| F50 - E27 - 9875000 | RD316         |

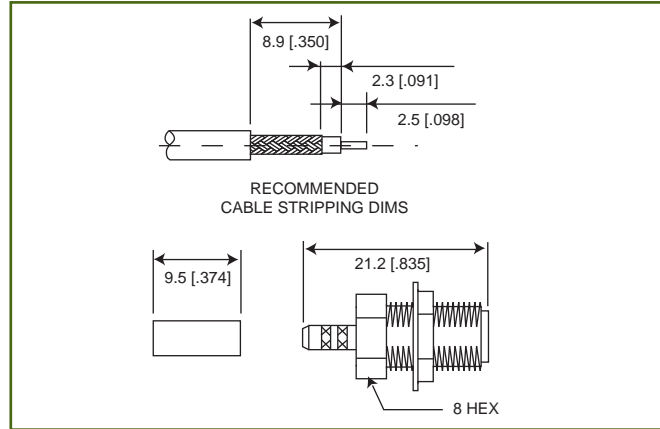

Assembly Instructions CSMA 1 (Page 54)  
Panel Mounting Plan W (Page 40)

**PRINTED CIRCUIT BOARD**

Straight Jack for Printed Circuit Board

| Part Number        | Cable Numbers |
|--------------------|---------------|
| F50 - E51- 0000000 | N/A           |

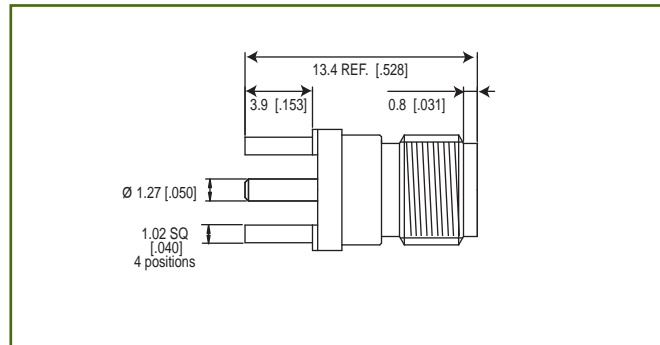

PCB Mounting Plan D (Page 40)

Right Angle Jack for Printed Circuit Board

| Part Number        | Cable Numbers |
|--------------------|---------------|
| F50 - E53- 0000000 | N/A           |

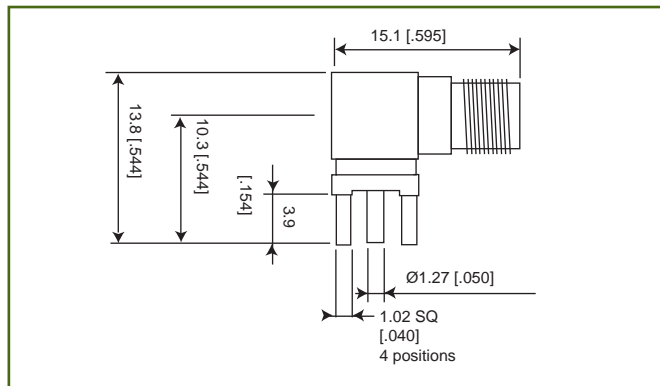

PCB Mounting Plan D (Page 40)



**DIRECT SOLDER FOR SEMI-RIGID CABLE**

Straight Cable Plug Without Contact

| Part Number         | Cable Numbers |
|---------------------|---------------|
| F55 - E07 - 2003000 | RG402         |

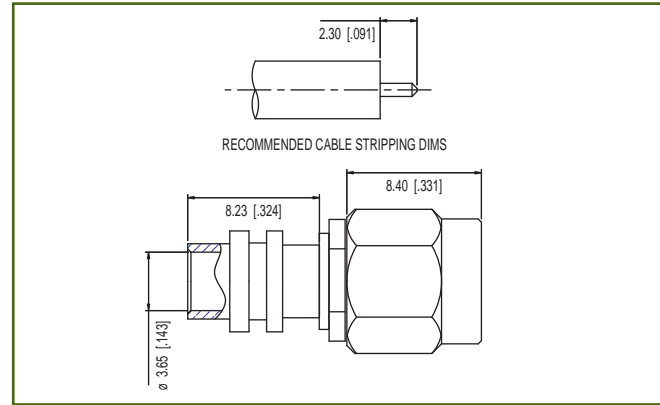

Assembly Instructions CSMA 3 (Page 55)

Straight Cable Plug With Contact

| Part Number         | Cable Numbers |
|---------------------|---------------|
| F55 - E07 - 9172000 | RG405         |
| F55 - E07 - 9173000 | RG402         |

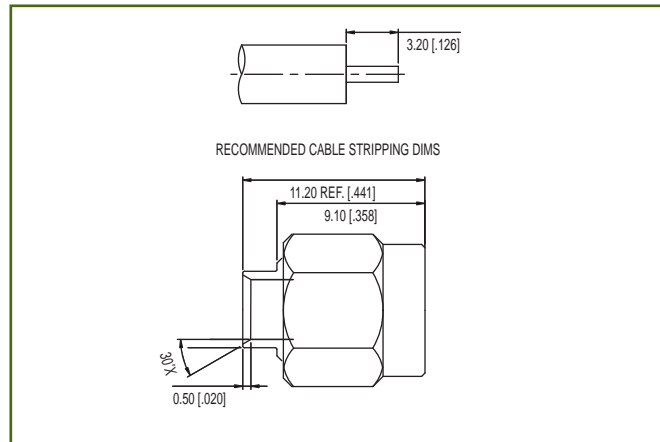

Assembly Instructions CSMA 4 (Page 56)

Right Angle Cable Plug

| Part Number         | Cable Numbers | A            | B           |
|---------------------|---------------|--------------|-------------|
| F55 - E11 - 3702000 | RG405         | 8,1 [0.319]  | 4,6 [0.181] |
| F55 - E11 - 3703000 | RG402         | 11,5 [0.453] | 8,1 [0.319] |

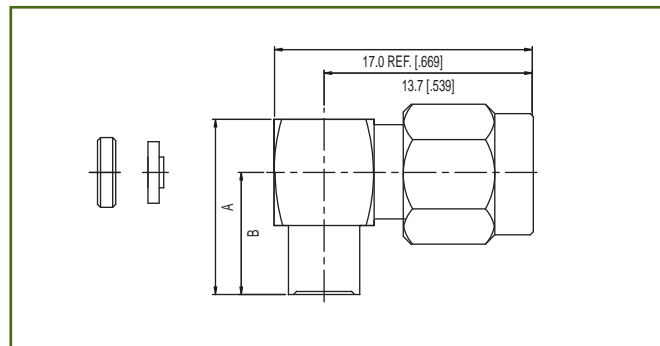

Assembly Instructions CSMA 5 (Page 57)

The designs shown in this catalogue are not the entire range. Examples of some of the many styles that are available on request are shown below. Should you require styles that are not shown please contact our nearest sales department listed on the back cover.

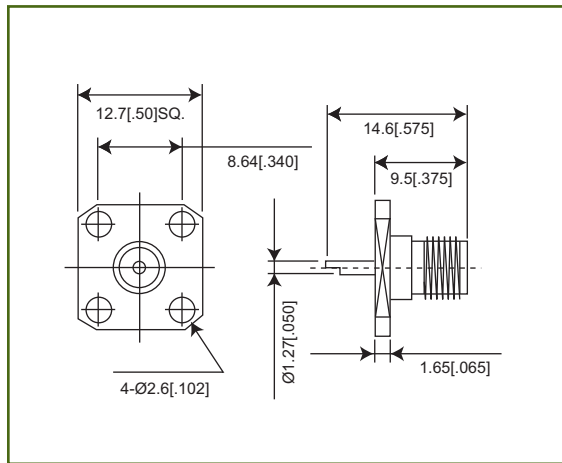

Panel Mount Jack - Solder Pot Contact

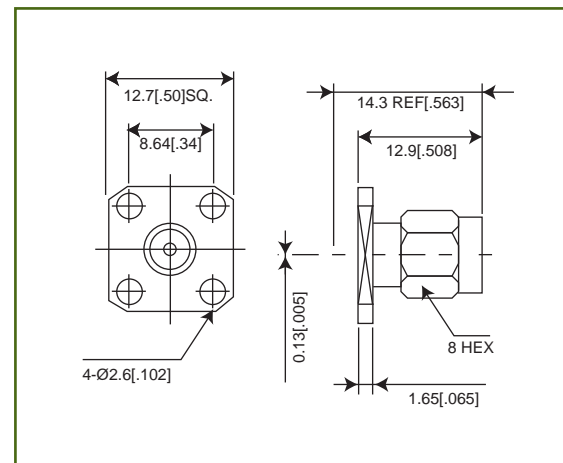

Panel Mount Plug - Tab Contact

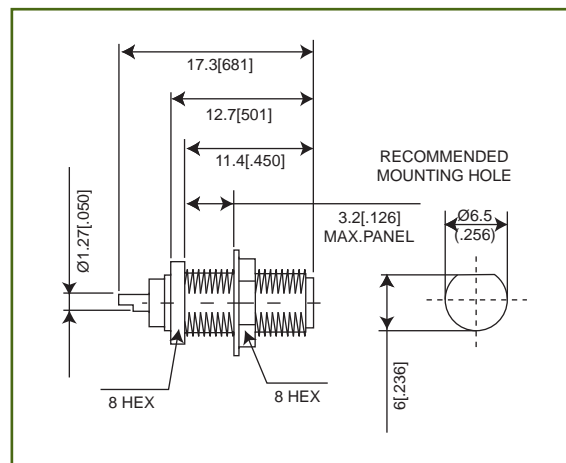

Bulkhead Mount Jack - Solder Pot Contact

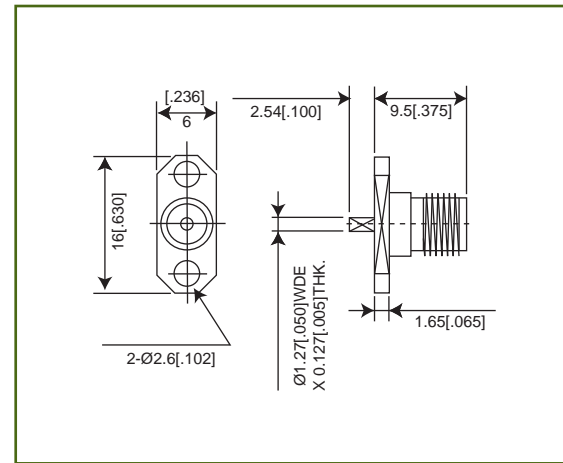

Panel Mount Plug - Tab Contact

Cannon's SMB Snap-on and SMC Screw-on subminiature coaxial connectors have been specifically engineered for high performance and high reliability applications in both military and commercial equipment operating at frequencies up to 4 GHz (SMB) and 12.4 GHz (SMC).

The Snap-on mating engagement allows a rapid connect/disconnect facility. The Screw-on mating engagement allows a low VSWR under vibration conditions and a matched impedance of 50 ohms.

Cannon SMB/SMC connectors are compatible with all SMB/SMC type connectors conforming with MIL-C-39012, BS 9210, UTE C93 561, UTE C93 562, CECC 22 130 and CECC 22 140.

In addition to this range we also offer FAKRA SMB connectors for automotive applications.



**Key Features**

- Rapid connect / disconnect (SMB)
- Standoff legs on PCB
- Frequency range to 12.4 GHz (SMC) or 4 GHz (SMB)
- Vibration withstanding design (SMC)

**MATING INTERFACES**

**SMB (SNAP-ON)**

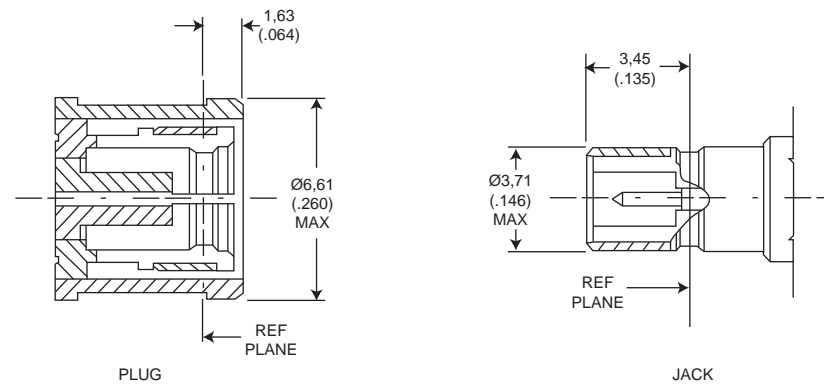

**SMC (SCREW-ON)**

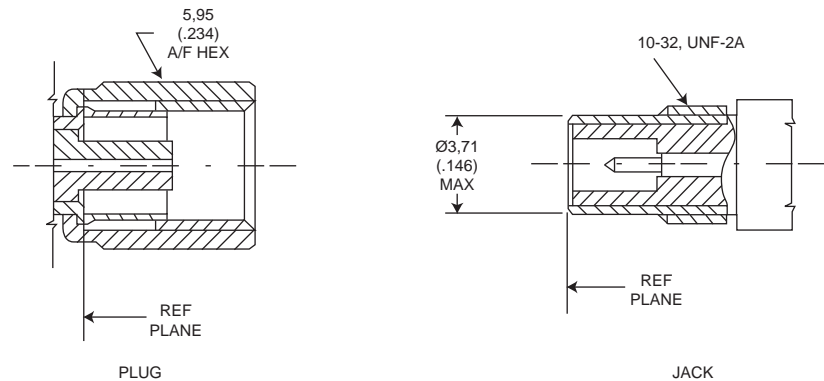

**NOTES**

1) Inside diameter of female contact to meet VSWR mating characteristics and connector durability when mated with a  $0,48 \pm 0,53$  (.019  $\pm$  .021) diameter male contact.

2) All undimensioned pictorial representations are for reference purposes only.

3) Slide-on versions of most SMB female styles, prefix 052, are available. For slide-on male interconnection use male SMB (snap-on type).

Dimensions shown in mm (inch)  
Specifications and dimensions subject to change

www.ittcannon.com



**SPECIFICATIONS**

| ELECTRICAL     | Impedance   | 50Ω  |             |             |  |             |     |  |     |  |          |             |          |             |                |             |             |             |             |                |             |             |             |             |
|----------------|---|--|-------------|-------------|--|-------------|-----|--|-----|--|----------|-------------|----------|-------------|----------------|-------------|-------------|-------------|-------------|----------------|-------------|-------------|-------------|-------------|
|                | Frequency Range   | SMB = 0 to 4.0 GHz. SMC = 0 to 12.4 GHz  |             |             |  |             |     |  |     |  |          |             |          |             |                |             |             |             |             |                |             |             |             |             |
|                | Voltage Rating  | Connectors for RG196/U series cable: At Sea Level = 300 Vrms. At 21km (70k feet) = 75 Vrms<br>Connectors for RG188/U series cable: At Sea Level = 400 Vrms. At 21km (70k feet) = 100 Vrms  |             |             |  |             |     |  |     |  |          |             |          |             |                |             |             |             |             |                |             |             |             |             |
|                | Insulation Resistance   | 1000 MΩ minimum  |             |             |  |             |     |  |     |  |          |             |          |             |                |             |             |             |             |                |             |             |             |             |
|                | Contact resistance  | Center Contact = 6.0 m Ω maximum initial. 8.0 m Ω maximum after environment<br>Outer Contact = 1.0 m Ω maximum initial. 1.5 m Ω maximum after environment<br>Braid to Body = 1.0 m Ω maximum   |             |             |  |             |     |  |     |  |          |             |          |             |                |             |             |             |             |                |             |             |             |             |
|                | Contact Current Rating  | 1.5 A dc maximum   |             |             |  |             |     |  |     |  |          |             |          |             |                |             |             |             |             |                |             |             |             |             |
|                | Insertion Loss  | 0.25 dB maximum @ 4 GHz  |             |             |  |             |     |  |     |  |          |             |          |             |                |             |             |             |             |                |             |             |             |             |
|                | RF Leakage  | SMB = -55 dB minimum @ 2 - 3 GHz<br>SMC = -60 dB minimum @ 2 - 3 GHz   |             |             |  |             |     |  |     |  |          |             |          |             |                |             |             |             |             |                |             |             |             |             |
|                | Voltage Standing Wave Ratio (VSWR)<br>To 10 GHz or 80% of upper cut-off<br>frequency of the cable, whichever is lower.<br>Applicable to 50Ω cables only.(F = GHz) | <table border="1"> <thead> <tr> <th rowspan="2">Cable group</th> <th colspan="2">SMB</th> <th colspan="2">SMC</th> </tr> <tr> <th>Straight</th> <th>Right Angle</th> <th>Straight</th> <th>Right Angle</th> </tr> </thead> <tbody> <tr> <td>RG196/U Series</td> <td>1.30 + .04F</td> <td>1.45 + .06F</td> <td>1.25 + .04F</td> <td>1.40 + .06F</td> </tr> <tr> <td>RG188/U Series</td> <td>1.20 + .04F</td> <td>1.35 + .04F</td> <td>1.20 + .04F</td> <td>1.30 + .04F</td> </tr> </tbody> </table> |             |             |  | Cable group | SMB |  | SMC |  | Straight | Right Angle | Straight | Right Angle | RG196/U Series | 1.30 + .04F | 1.45 + .06F | 1.25 + .04F | 1.40 + .06F | RG188/U Series | 1.20 + .04F | 1.35 + .04F | 1.20 + .04F | 1.30 + .04F |
|                | Cable group   | SMB  |             | SMC         |  |             |     |  |     |  |          |             |          |             |                |             |             |             |             |                |             |             |             |             |
| Straight       |   | Right Angle  | Straight    | Right Angle |  |             |     |  |     |  |          |             |          |             |                |             |             |             |             |                |             |             |             |             |
| RG196/U Series | 1.30 + .04F   | 1.45 + .06F  | 1.25 + .04F | 1.40 + .06F |  |             |     |  |     |  |          |             |          |             |                |             |             |             |             |                |             |             |             |             |
| RG188/U Series | 1.20 + .04F   | 1.35 + .04F  | 1.20 + .04F | 1.30 + .04F |  |             |     |  |     |  |          |             |          |             |                |             |             |             |             |                |             |             |             |             |
| MECHANICAL     | Engagement Design   | SMB per MIL-C-39012, Series SMB. SMC per MIL-C-39012, Series SMC.  |             |             |  |             |     |  |     |  |          |             |          |             |                |             |             |             |             |                |             |             |             |             |
|                | Engagement Forces   | SMB: Initial = 62 N (14 lbs.) max. engagement. After 500 matings = 62 N (14 lbs.)<br>max. engagement and disengagement = 8.9 N (2 lbs.) min. disengagement. SMC:<br>0.11 Nm (16 in. oz. ) torque max.  |             |             |  |             |     |  |     |  |          |             |          |             |                |             |             |             |             |                |             |             |             |             |
|                | Mating Torque   | SMB: N/A SMC: 0.42 to 0.50 Nm (60 to 70 in.oz)   |             |             |  |             |     |  |     |  |          |             |          |             |                |             |             |             |             |                |             |             |             |             |
|                | Locknut Torque  | 0.56 to 0.64 Nm (80 to 90 in. oz)  |             |             |  |             |     |  |     |  |          |             |          |             |                |             |             |             |             |                |             |             |             |             |
|                | Coupling Nut Retention  | SMB: N/A SMC: 155 N (35 lbs. ) minimum   |             |             |  |             |     |  |     |  |          |             |          |             |                |             |             |             |             |                |             |             |             |             |
|                | Materials   | Body, Body Components and Male Contacts: Brass, half hard. Female Contacts:<br>Beryllium Copper, heat treated. Insulators: PTFE. Lockwashers: Phosphor Bronze. Crimp<br>Ferrule: Annealed copper alloy. Gaskets: Silicone rubber   |             |             |  |             |     |  |     |  |          |             |          |             |                |             |             |             |             |                |             |             |             |             |
| ENVIRONMENTAL  | Finish/Plating  | Center Contacts: Gold plated. Other Metal Parts: Gold plated or nickel plated (as<br>specified) to meet the finish and corrosion requirements of MIL-C-39012   |             |             |  |             |     |  |     |  |          |             |          |             |                |             |             |             |             |                |             |             |             |             |
|                | Temperature Rating  | -65° C to 165° C   |             |             |  |             |     |  |     |  |          |             |          |             |                |             |             |             |             |                |             |             |             |             |
|                | Corrosion (salt spray)  | MIL-STD-202, Method 101, test condition B, 5% salt solution  |             |             |  |             |     |  |     |  |          |             |          |             |                |             |             |             |             |                |             |             |             |             |
|                | Vibration, High Frequency   | MIL-STD-202, Method 204, SMB: test condition B (15 G's). SMC: test condition D (20 G's)  |             |             |  |             |     |  |     |  |          |             |          |             |                |             |             |             |             |                |             |             |             |             |
|                | Shock   | MIL-STD-202, Method 213, SMB: test condition B, 75 G's @ 6 milliseconds, 1/2 sine.<br>SMC: test condition C, 100 G's @ 6 milliseconds, 1/2 sine.   |             |             |  |             |     |  |     |  |          |             |          |             |                |             |             |             |             |                |             |             |             |             |
|                | Thermal Shock   | MIL-STD-202, Method 107, test condition B, except high temperature shall be 85°C.<br>High temperature shall be 200°C for connectors using 200°C cables.  |             |             |  |             |     |  |     |  |          |             |          |             |                |             |             |             |             |                |             |             |             |             |
|                | Moisture Resistance   | MIL-STD-202, Method 106, when interface gasket is used. No measurement at high humidity.<br>Insulation resistance shall be 200 MΩ minimum within five minutes after removal from humidity.   |             |             |  |             |     |  |     |  |          |             |          |             |                |             |             |             |             |                |             |             |             |             |
| GENERAL        | Connector Durability  | 500 matings minimum  |             |             |  |             |     |  |     |  |          |             |          |             |                |             |             |             |             |                |             |             |             |             |
|                | Contact Captivation   | Unless otherwise specified, all connectors feature captivated contacts. When captivated the<br>contacts will withstand 17,8 N (4 lbs.) minimum axial force. CECC 22 130 = 10 N(2.25 lb.)   |             |             |  |             |     |  |     |  |          |             |          |             |                |             |             |             |             |                |             |             |             |             |
|                | Cable Retention   | When properly assembled to the compatible single braided coaxial cable, the<br>retention is equal to the breaking strength of the cable.   |             |             |  |             |     |  |     |  |          |             |          |             |                |             |             |             |             |                |             |             |             |             |
|                | Body Plating Options  | The following part number suffices can be specified for SMB/SMC Connectors:<br>..... 220 gold body<br>..... 910 nickel body<br>..... C90 nickel body   |             |             |  |             |     |  |     |  |          |             |          |             |                |             |             |             |             |                |             |             |             |             |

**STRAIGHT PLUGS AND JACKS**

**Straight Crimp Plug**

| Part Number         | Cable Numbers  |
|---------------------|----------------|
| B51 - 024 - 0000220 | RG174/U, 316/U |
| B51 - 024 - 3196220 | RG178/U, 196/U |
| B51 - 024 - 9399220 | RD316, 179     |

SMB connectors have solder center contacts.

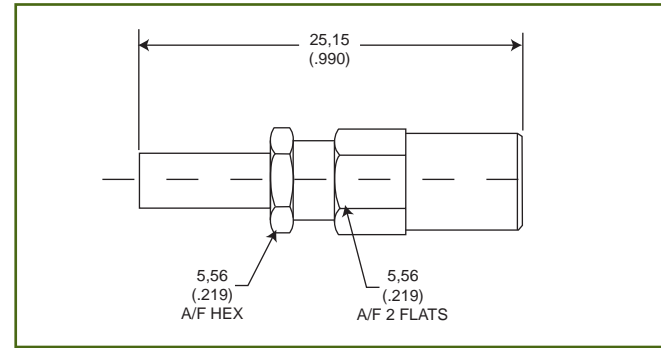

Assembly Instructions BAI-003 (Page 50)

**Straight Crimp Bulkhead Jack**

| Part Number         | Cable Numbers  |
|---------------------|----------------|
| 051 - 027 - 0000220 | RG174/U, 316/U |
| 051 - 027 - 3196220 | RG178/U, 196/U |
| 051 - 027 - 9399220 | RD316, 179     |

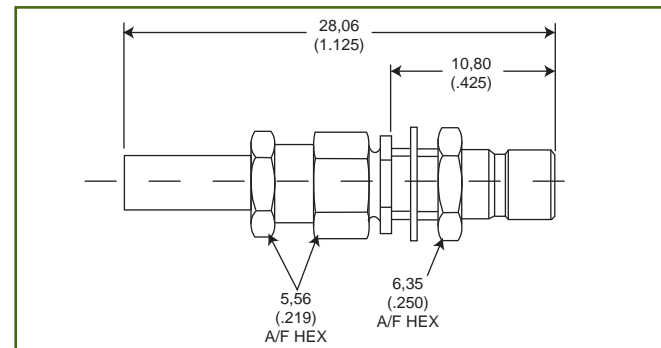

Mounting Plan V (Page 40)  
Assembly Instructions BAI-003 (Page 50)

**RIGHT ANGLE PLUGS**

**Right Angle Crimp Plug**

| Part Number         | Cable Numbers    |
|---------------------|------------------|
| B51 - 328 - 3188220 | RG174/U, 316/U   |
| B51 - 328 - 3196220 | RG178/U, 196/U   |
| B51 - 328 - 9399220 | RD316, 179       |
| B51 - 328 - 9019AU0 | BT3002, T2C75024 |

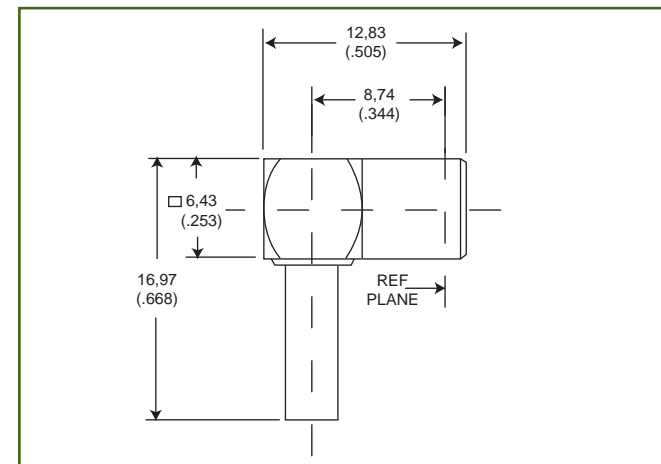

Assembly Instructions BAI-015 (Page 49)

**IN-SERIES ADAPTORS**

**Jack to Jack Adaptor, Bulkhead Mounting**

| Part Number         |
|---------------------|
| 051 - 075 - 0000220 |

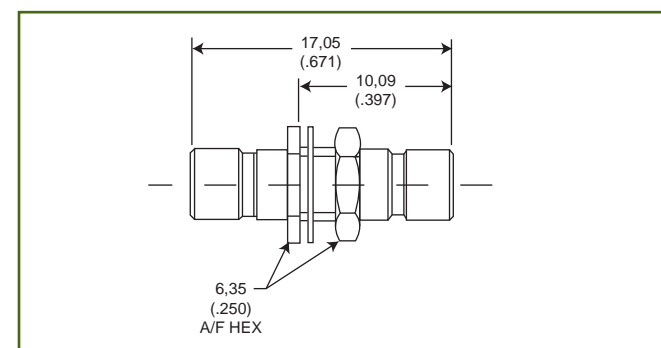

Mounting Plan V (Page 40)



**BULKHEAD JACKS**

Straight Bulkhead Jack, Solder Pot,  
Mounting Nut Outside Panel

Part Number

051 - 043 - 0000220

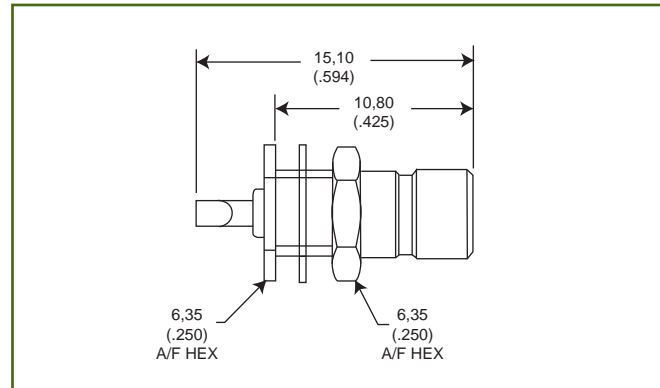

Mounting Plan V (Page 40)

Straight Bulkhead Jack, Solder Pot,  
Mounting Nut Inside Panel

Part Number

051 - 045 - 0000220

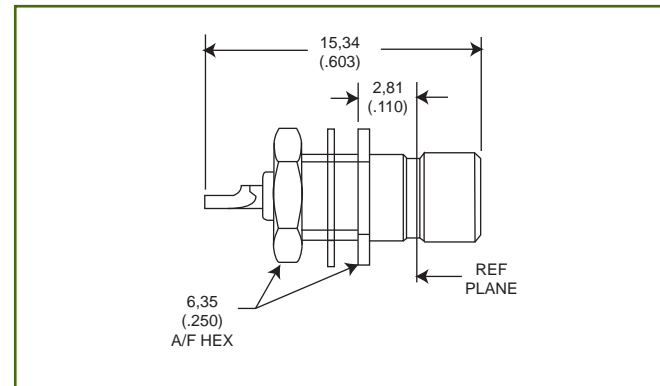

Mounting Plan V (Page 40)

Right Angle Bulkhead Jack, Solder Pot,  
Mounting Nut Inside Panel

Part Number

051 - 047 - 0000220

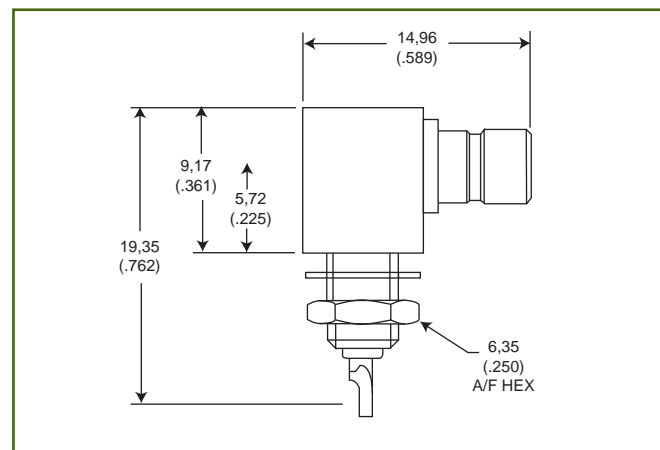

Mounting Plan V (Page 40)

**PRINTED CIRCUIT BOARD JACKS**

SMB PCB preferred styles feature stepped legs. This allows the jacks to be raised from the surface of the PCB, thereby preventing the accumulation of soldering fluids and foreign bodies. A single piece conductor overcomes the problem of internal joint separation during continuous wave / flow soldering operations.

Straight PCB Jack, 1,00 (.039) sq Legs

|                     |
|---------------------|
| Part Number         |
| B51 - 351 - 0000220 |

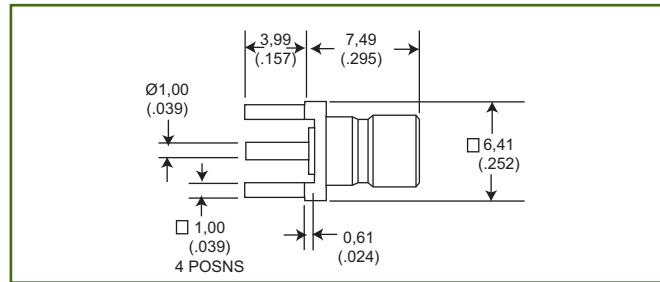

Mounting Plan A (Page 40)

Straight PCB Jack, 0,81 (.032) sq Legs

|                     |
|---------------------|
| Part Number         |
| B51 - 051 - 9029220 |

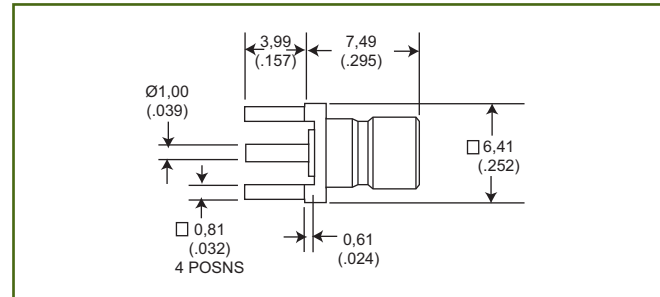

Mounting Plan B (Page 40)

Right Angle PCB Jack, 1,00 (.039) sq Legs

|                     |
|---------------------|
| Part Number         |
| B51 - 053 - 0000220 |

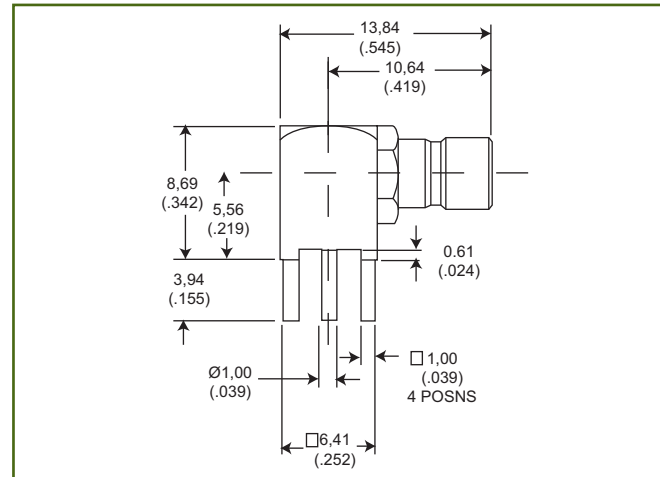

Mounting Plan A (Page 40)

Right Angle PCB Jack, 0,81 (.032) sq Legs

|                     |
|---------------------|
| Part Number         |
| B51 - 053 - 9029220 |

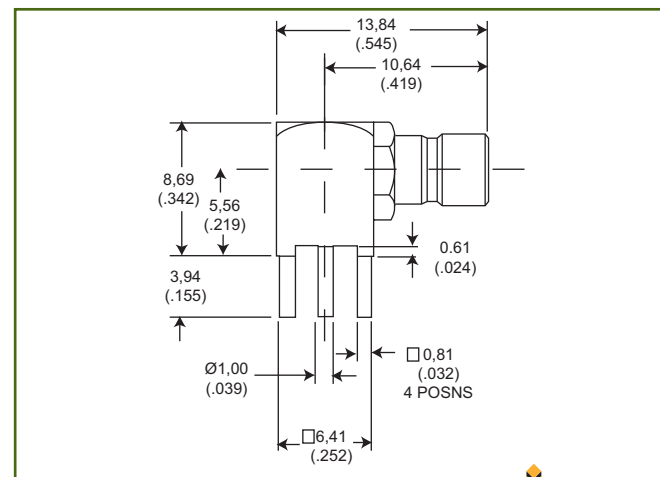

Mounting Plan B (Page 40)



Dimensions shown in mm (inch)  
Specifications and dimensions subject to change

**STRAIGHT PLUGS AND JACKS**

**Straight Clamp Plug**

| Part Number         | Cable Numbers  |
|---------------------|----------------|
| 050 - 007 - 0000220 | RG174/U, 316/U |

SMC CONNECTORS HAVE SOLDER CENTER CONTACTS

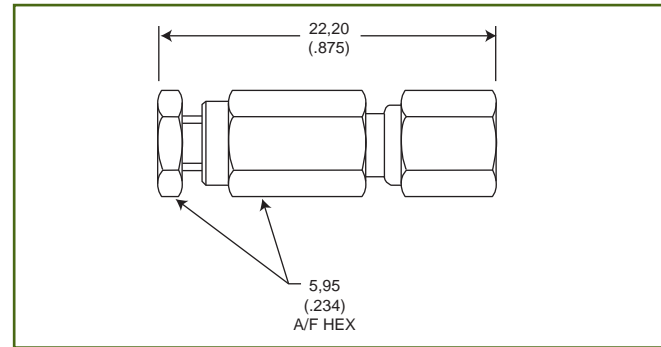

Assembly Instructions BAI-001 (Page 52)

**Straight Crimp Plug**

| Part Number         | Cable Numbers  |
|---------------------|----------------|
| 050 - 024 - 0000220 | RG174/U, 316/U |

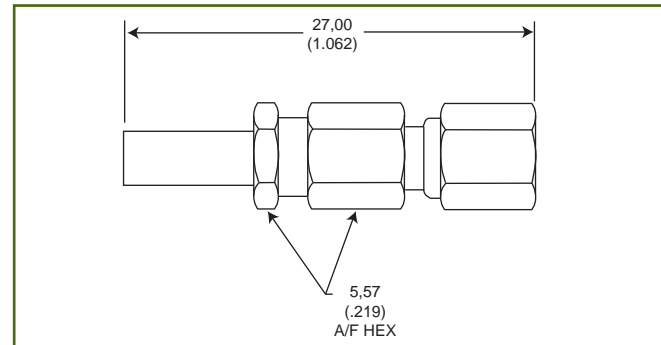

Assembly Instructions BAI-003 (Page 50)

**Straight Crimp Bulkhead Jack**

| Part Number         | Cable Numbers  |
|---------------------|----------------|
| 050 - 027 - 0000220 | RG174/U, 316/U |

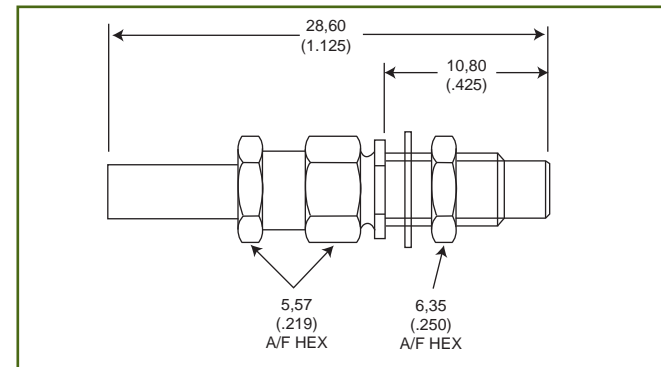

Mounting Plan V (Page 40)  
Assembly Instructions BAI-003 (Page 50)

**RIGHT ANGLE PLUGS**

**Right Angle Crimp Plug**

| Part Number         | Cable Numbers  |
|---------------------|----------------|
| B50 - 328 - 3188220 | RG174/U, 316/U |
| B50 - 328 - 9399220 | RD316, 179     |

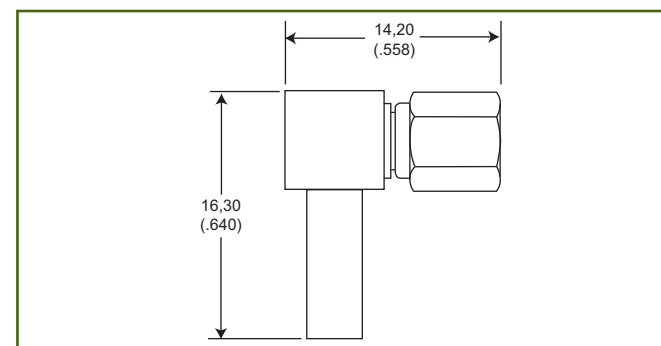

Assembly Instructions  
BAI-015 (Page 49)





**BULKHEAD JACKS**

Straight Bulkhead Jack, Solder Pot,  
Mounting Nut outside Panel

Part Number

050 - 043 - 0000220

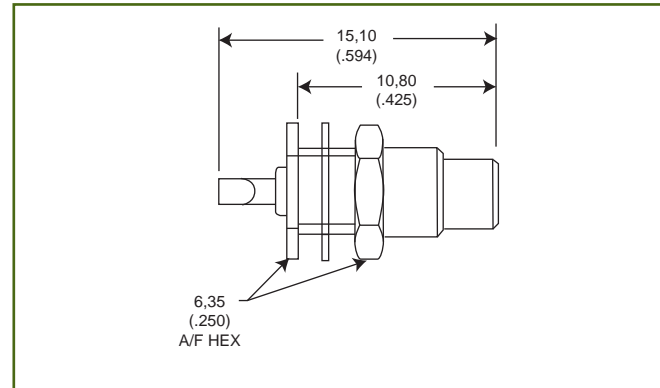

Mounting Plan V (Page 40)

Straight Bulkhead Jack, Solder Pot ,  
Mounting Nut inside Panel

Part Number

050 - 045 - 0000220

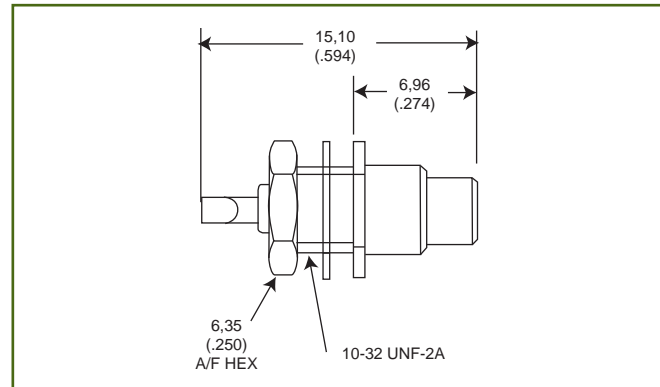

Mounting Plan V (Page 40)

Right Angle Bulkhead Jack, Solder Pot,  
Mounting Nut inside Panel

Part Number

050 - 047 - 0000220

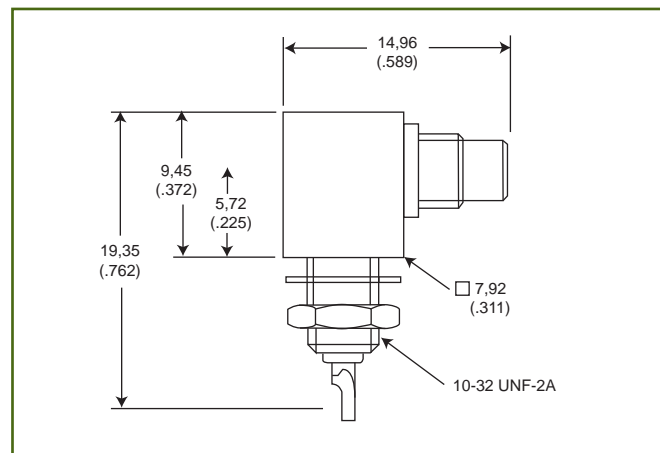

Mounting Plan V (Page 40)

Dimensions shown in mm (inch)  
Specifications and dimensions subject to change

**PRINTED CIRCUIT BOARD JACKS**

SMC PCB preferred styles feature stepped legs. This allows the jacks to be raised from the surface of the PCB, thereby preventing the accumulation of soldering fluids and foreign bodies. A single piece conductor overcomes the problem of internal joint separation during continuous wave/flow soldering operations.

Straight PCB Jack, 1,00 (.039) square legs

|                     |
|---------------------|
| Part Number         |
| B50 - 051 - 0000220 |

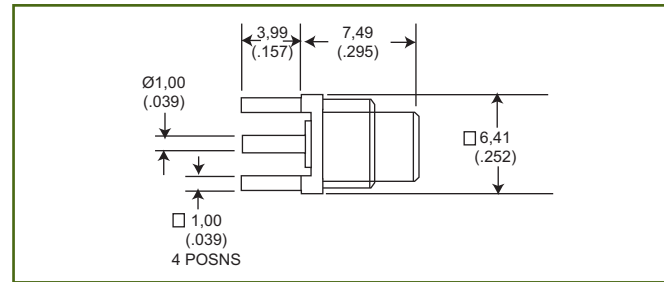

Mounting Plan A (Page 40)

Straight PCB Jack, 0,81 (.032) square legs

|                     |
|---------------------|
| Part Number         |
| B50 - 051 - 9019220 |

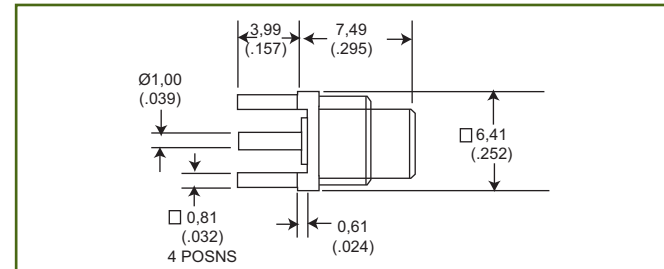

Mounting Plan B (Page 40)

Right Angle PCB Jack, 1,00 (.039) square legs

|                     |
|---------------------|
| Part Number         |
| B50 - 053 - 0000220 |

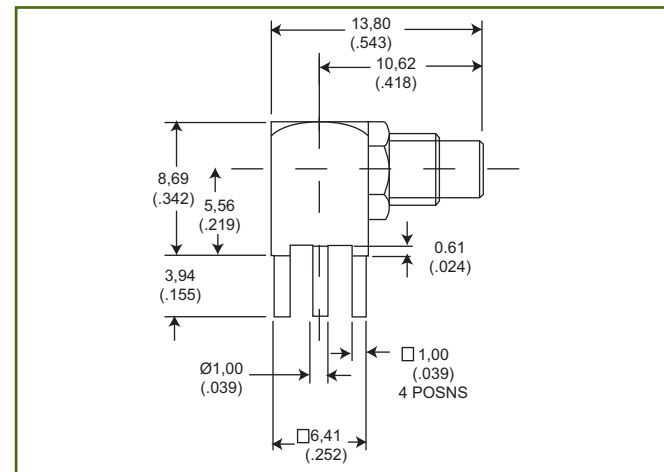

Mounting Plan A (Page 40)

Right Angle PCB Jack, 0,81 (.032) sq Legs

|                     |
|---------------------|
| Part Number         |
| B50 - 053 - 9019220 |

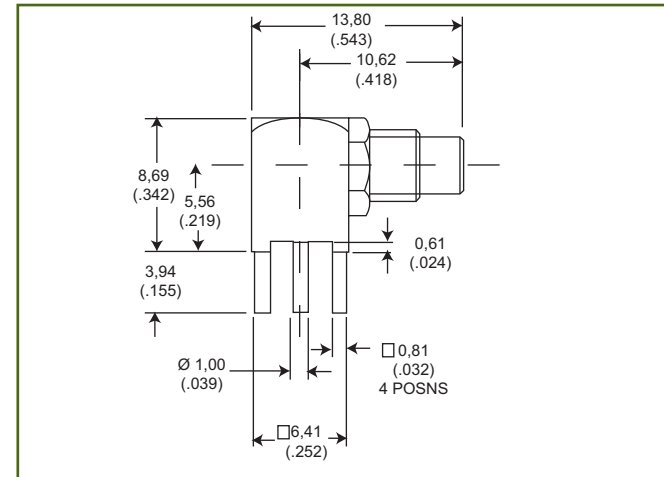

Mounting Plan B (Page 40)



This range of 50 ohm microminiature radio frequency connectors is suitable for both military and commercial equipment operating at frequencies up to 4 GHz (SSMB) and 12.4 GHz (SSMC). They provide a choice of Snap-on (SSMB) or Screw-on (SSMC) and are available for a wide range of flexible cables.



SSMC connectors are used where a positive mechanical engagement is required and where space permits the use of torque wrenches. SSMB connectors are quick disconnect versions of the SSMC and are used in applications where limited space prohibits the use of torque wrenches or when components or modules must be quickly changed to keep down time to a minimum.

**Key Features**

- Small size
- Low mass
- Close packing density
- Used in airborne applications

**MATING INTERFACE**

**SSMB (SNAP-ON)**

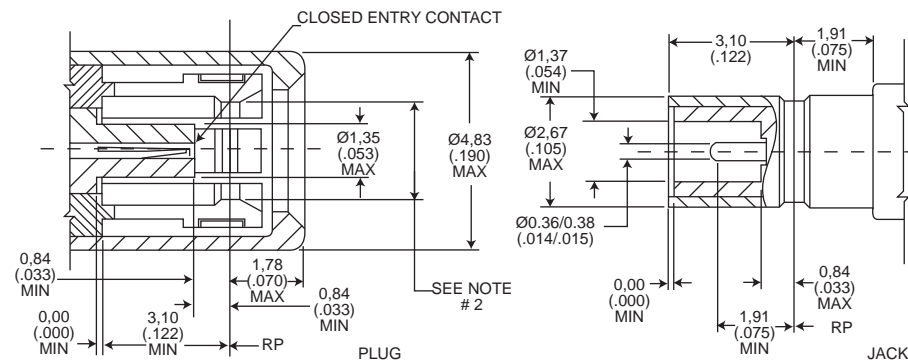

**SSMC (SCREW-ON)**

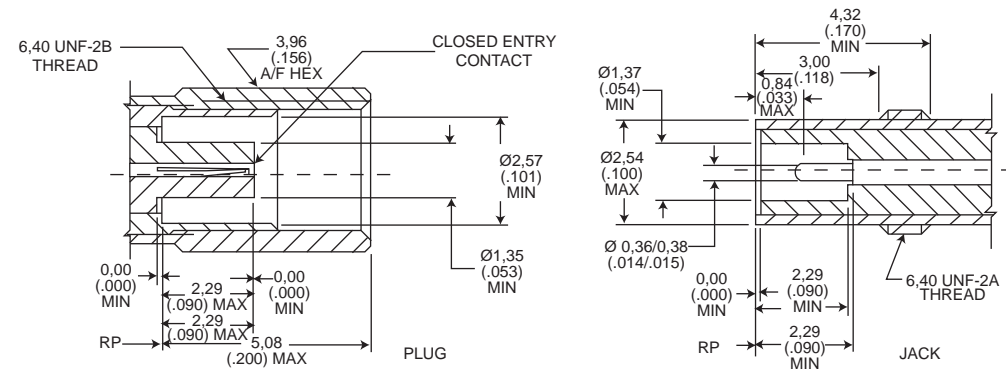

**NOTES**

1) Inside diameter of female contact to meet VSWR, mating characteristics and connector durability, when mated with a 0,36 - 0,38 (.014 - .015) diameter male contact.

2) Must meet the force to engage and disengage when mated with its mating part.

Dimensions shown in mm (inch)  
Specifications and dimensions subject to change

www.ittcannon.com



**SPECIFICATIONS**

|               |   |   |             |             |             |  |
|---------------|---|---|-------------|-------------|-------------|--|
| ELECTRICAL    | Impedance   | 50Ω   |             |             |             |  |
|               | Frequency Range   | SSMB = 0 to 4.0 GHz. SSMC = 0 to 12.4 GHz   |             |             |             |  |
|               | Voltage Rating  | At Sea Level = 250 Vrms. at 21km (70k feet) = 60 Vrms   |             |             |             |  |
|               | Insulation Resistance   | 1000 MΩ minimum   |             |             |             |  |
|               | Contact resistance  | Center Contact = 4.0 m Ω maximum initial. 6.0 m Ω maximum after environment<br>Outer Contact = 1.0 m Ω maximum initial. 1.5 m Ω maximum after environment<br>Braid to Body = 1.0 m Ω maximum                                    |             |             |             |  |
|               | Contact Current Rating  | 1.0 A dc maximum  |             |             |             |  |
|               | Insertion Loss  | 0.30 dB maximum @ 1.5 GHz   |             |             |             |  |
|               | RF Leakage  | SSMB = -40 dB minimum @ 2 - 3 GHz<br>SSMC = -50 dB minimum @ 2 - 3 GHz  |             |             |             |  |
|               | Voltage Standing Wave Ratio (VSWR)<br>To 12.4 GHz or 80% of upper cut-off<br>frequency of the cable, whichever is lower.<br>Applicable to 50Ω cables only.(F = GHz) | Connector Configuration   |             |             |             |  |
|               |   |   | SSMB        |             | SSMC        |  |
|               | Cable group   | Straight  | Right Angle | Straight    | Right Angle |  |
|               | RG178/U, 196/U  | 1.25 + .02F   | 1.25 + .03F | 1.20 + .02F | 1.20 + .03F |  |
|               | RG188/U, 316/U  | 1.30 + .02F   | 1.30 + .03F | 1.25 + .03F | 1.30 + .02F |  |
| MECHANICAL    | Engagement Forces   | SSMB: Initial = 26.7 N (6 lbs.) max. engagement and 8.9 N(2 lbs.) minimum disengagement.<br>After 500 matings = 26.7 N (6 lbs.) max. engagement and 4.4 N (1 lb.) min. disengagement.<br>SSMC: 0.11 Nm (16 in. oz.) torque max. |             |             |             |  |
|               | Mating Torque   | SSMB: N/A SSMC: 0.2 Nm to 0.23 Nm (28 - 32 in.oz)   |             |             |             |  |
|               | Locknut Torque  | 0.28 Nm to 0.35 Nm (40 - 50 in. oz)   |             |             |             |  |
|               | Coupling Nut Retention  | SSMB: N/A SSMC: 111 N (25 lbs. ) minimum  |             |             |             |  |
|               | Materials   | Body, Body Components: Brass, half hard. Male and Female Contacts: Beryllium Copper.<br>Insulators: PTFE. Lockwashers: Phosphor Bronze. Crimp Ferrule: Annealed copper alloy.   |             |             |             |  |
| ENVIRONMENTAL | Finish/Plating  | Center Contacts: Gold plated. Other Metal Parts: Gold or nickel plated to meet the<br>finish and corrosion requirements of MIL-C-39012  |             |             |             |  |
|               | Temperature Rating  | -65° C to 165° C  |             |             |             |  |
|               | Corrosion (salt spray)  | MIL-STD-202, Method 101, test condition B, 5% salt solution   |             |             |             |  |
|               | Vibration, High Frequency   | MIL-STD-202, Method 204, SSMB: test condition B (15 G's). SSMC: test condition D (20 G's)   |             |             |             |  |
|               | Shock   | MIL-STD-202, Method 213, SSMB: test condition B, 75 G's @ 6 milliseconds, 1/2 sine.<br>SSMC: test condition C, 100 G's @ 6 milliseconds, 1/2 sine.  |             |             |             |  |
| GENERAL       | Thermal Shock   | MIL-STD-202, Method 107, test condition B, except high temperature shall be 85° C.<br>High temperature shall be 200°C for connectors using 200°C cables.  |             |             |             |  |
|               | Connector Durability  | 500 matings minimum   |             |             |             |  |
|               | Contact Captivation   | 8,9 N (2 lbs.) minimum axial force.   |             |             |             |  |
|               | Cable Retention   | When properly assembled to the compatible single braided coaxial cable, the retention<br>is equal to the breaking strength of the cable.  |             |             |             |  |

Body plating options

The following part number suffices can be specified for SSMB and SSMC connectors.

...220 gold body

...910 nickel body

**PLUGS, JACKS AND RECEPTACLES**

**Straight Plug**

| Part Number         | Cable Numbers  | A            |
|---------------------|----------------|--------------|
| 051 - 424 - 3188220 | RG174/U, 316/U | 20,01 (.790) |
| A51 - 424 - 3196220 | RG178/U, 196/U | 19,33 (.761) |

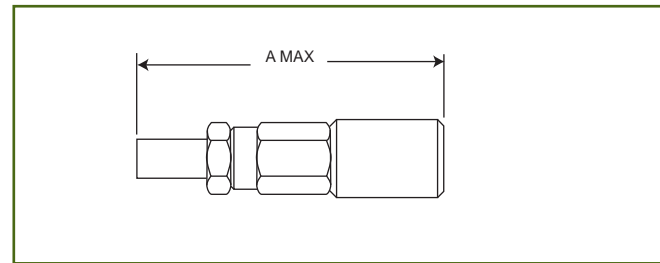

**Assembly Instructions**

- 051 - 424 - 3188220 AI 663 (Page 44)
- A51 - 424 - 3196220 AI 128 (Page 44)

**Right Angle Plug**

| Part Number         | Cable Numbers  | A            |
|---------------------|----------------|--------------|
| A51 - 428 - 3188220 | RG174/U, 316/U | 9,55 (.376)  |
| A51 - 428 - 3196220 | RG178/U, 196/U | 9,55 (.376)  |
| A51 - 428 - 3875220 | RD316          | 10,16 (.400) |

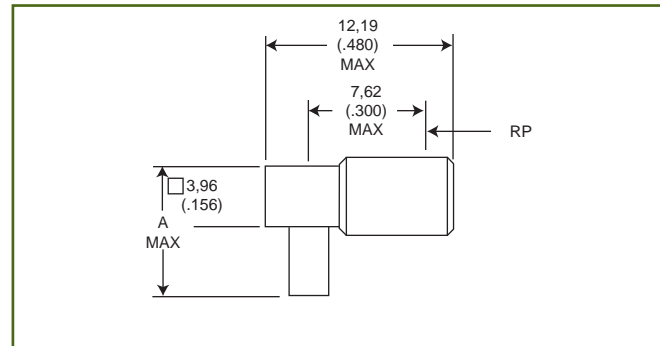

**Assembly Instructions**

- A51 - 428 - 3188220 AI 129 (Page 45)
- A51 - 428 - 3196220 AI 696 (Page 45)
- A51 - 428 - 3875220 AI 696 (Page 45)

**Bulkhead Jack**

| Part Number         | Cable Numbers  | A            |
|---------------------|----------------|--------------|
| 051 - 427 - 3188220 | RG174/U, 316/U | 9,93 (.391)  |
| A51 - 427 - 3196220 | RG178/U, 196/U | 10,41 (.410) |

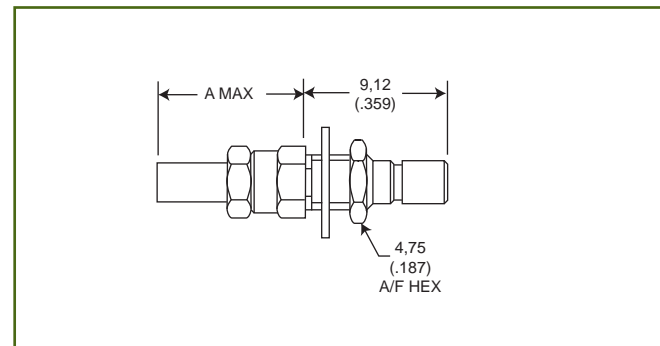

**Mounting Plan U (Page 40)**

Assembly Instructions AI-128 (Page 44)

**Bulkhead Receptacle - Rear Mount  
Mounting Nut Outside Panel**

| Part Number         |
|---------------------|
| 051 - 443 - 0000220 |

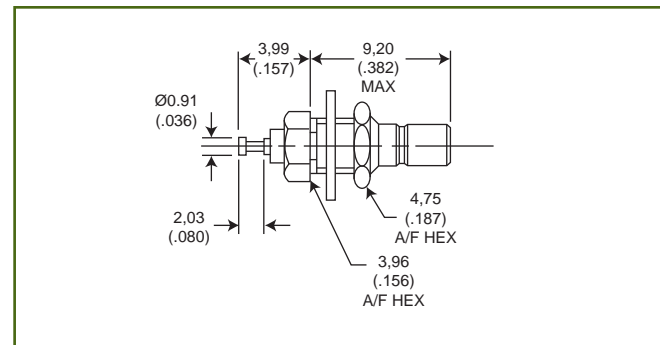

**Mounting Plan U (Page 40)**

Dimensions shown in mm (inch)  
Specifications and dimensions subject to change



**BULKHEAD AND PRINTED CIRCUIT RECEPTACLES**

Bulkhead Receptacle - Front Mount  
Mount Nut Inside Panel

|                     |
|---------------------|
| Part Number         |
| 051 - 445 - 0000220 |

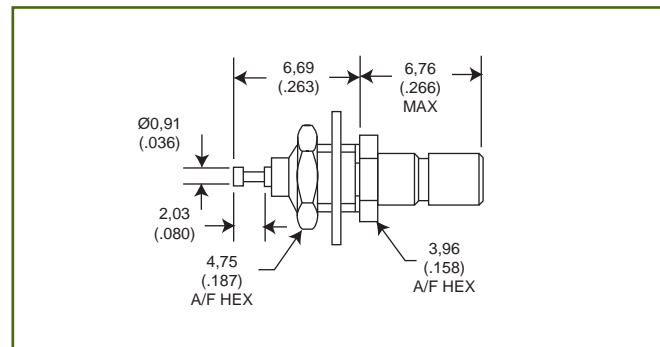

Mounting Plan U (Page 40)

Printed Circuit Receptacle - Straight Jack

|                     |
|---------------------|
| Part Number         |
| A51 - 451 - 0000220 |

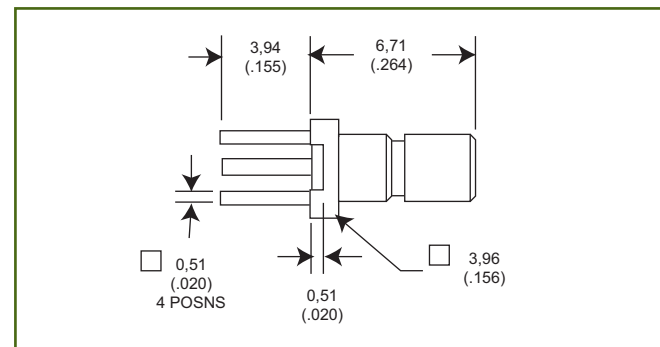

Mounting Plan C (Page 40)

Printed Circuit Receptacle - Straight Plug

|                     |
|---------------------|
| Part Number         |
| 051 - 452 - 0000220 |

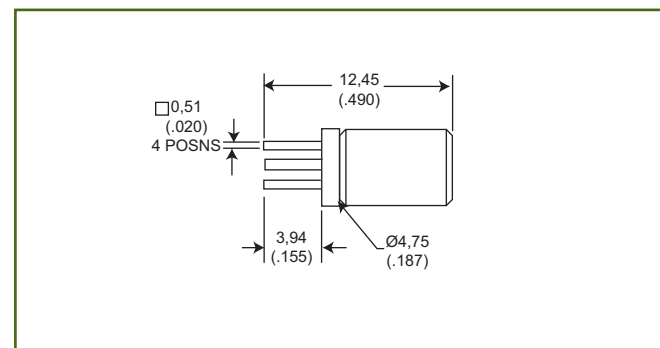

Mounting Plan C (Page 40)

Printed Circuit Receptacle - Right Angle Jack

|                     |
|---------------------|
| Part Number         |
| A51 - 453 - 0000220 |

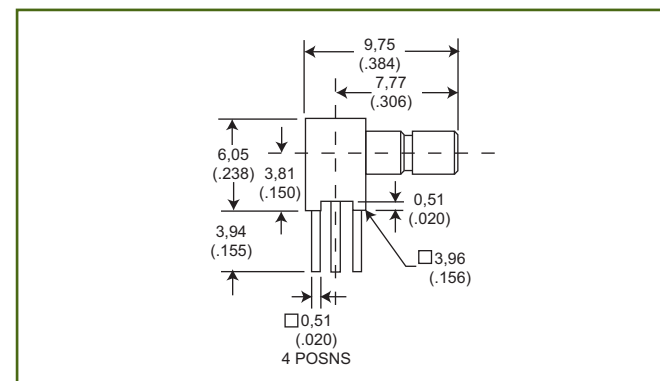

Mounting Plan C (Page 40)



**PLUGS AND RECEPTACLES**

Straight Plug

| Part Number         | Cable Numbers  |
|---------------------|----------------|
| 050 - 424 - 3188220 | RG174/U, 316/U |
| 050 - 424 - 3196220 | RG178/U, 196/U |

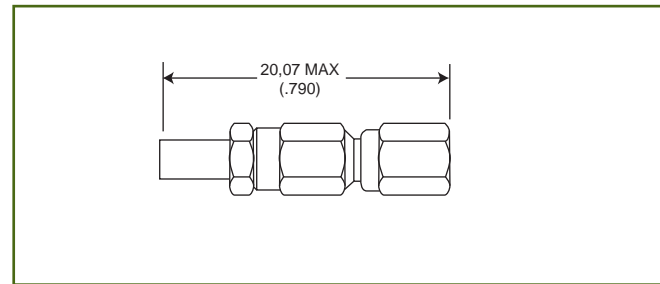

Assembly Instructions  
 050 - 424 - 3188220 AI 663 (Page 44)  
 050 - 424 - 3196220 AI 128 (Page 44)

Right Angle Plug

| Part Number         | Cable Numbers  | A            |
|---------------------|----------------|--------------|
| 050 - 428 - 3188220 | RG174/U, 316/U | 10,16 (.400) |
| 050 - 428 - 3196220 | RG178/U, 196/U | 9,40 (.370)  |

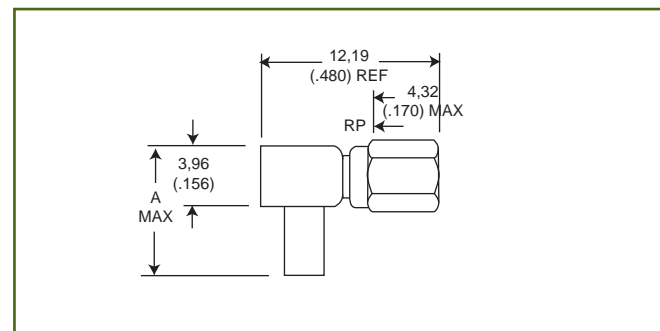

Assembly Instructions  
 050 - 428 - 3188220 AI 286 (Page 45)  
 050 - 428 - 3196220 AI 696 (Page 45)

Bulkhead Receptacle - Rear Mount  
 Mounting Nut Outside Panel

| Part Number         |
|---------------------|
| 050 - 443 - 0000220 |

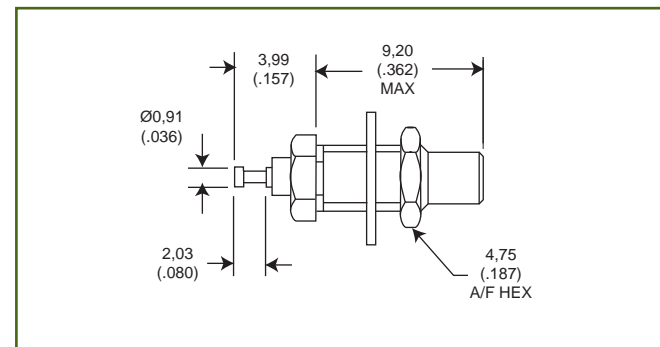

Mounting Plan U (Page 40)

Bulkhead Receptacle - Front Mount  
 Mounting Nut Inside Panel

| Part Number         |
|---------------------|
| 050 - 445 - 0000220 |

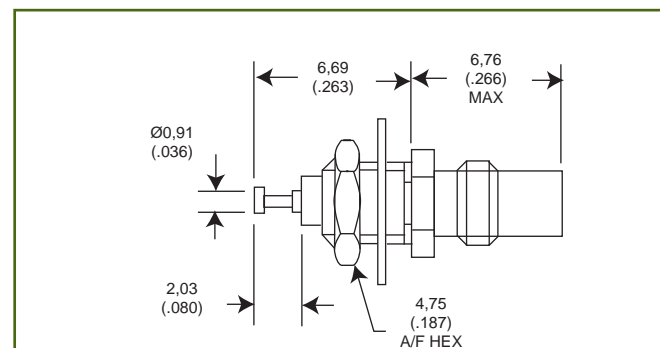

Mounting Plan U (Page 40)

Dimensions shown in mm (inch)  
 Specifications and dimensions subject to change



**PRINTED CIRCUIT RECEPTACLES**

Printed Circuit Receptacle - Straight Jack

|                     |
|---------------------|
| Part Number         |
| 050 - 451 - 0000220 |

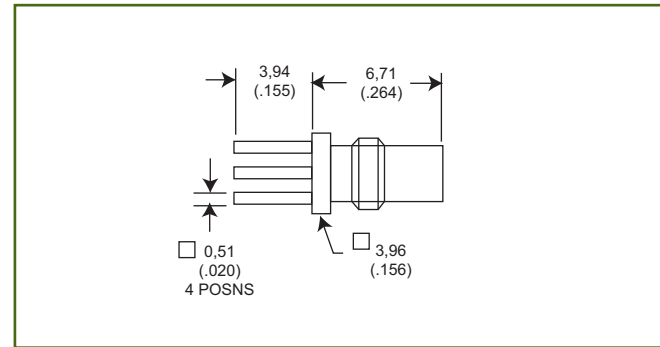

Mounting Plan C (Page 40)

Printed Circuit Receptacle, Right Angle Jack

|                     |
|---------------------|
| Part Number         |
| 050 - 453 - 0000220 |

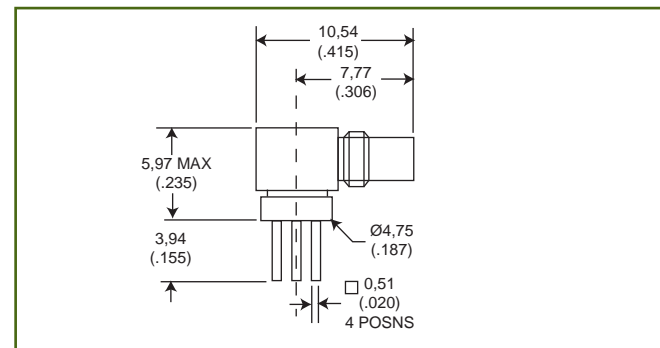

Mounting Plan C (Page 40)



Cannon's Coaxial Terminators provide a low cost means of joining cable to a printed circuit where engagement and disengagement are not required. This method of terminating cable on PCBs eliminates the inconsistency associated with hard wiring.

Styles are available for a variety of popular RG series cable types and cables of similar dimensions. The tapered leg is an interference fit into the PCB hole enabling pre-assembly for wave soldering.

All parts have electro-plated tin finish.



Coaxial Terminators feature:

- Low cost
- Easy to assemble
- Only two piece parts
- Surface mount option
- No solder transfer down braid
- Good stability ± two point fixing
- Variable pitch, 2,50 (.098) ± 10,00 (.393)

**TERMINATORS**

Single Leg

| Part Number         | Cable Numbers                |
|---------------------|------------------------------|
| 055 - 939 - 9019AR6 | RG178/U, 196/U               |
| 055 - 939 - 9029AR6 | RG174/U, 179/U, 188/U, 316/U |

NOTE

Both part numbers may be assembled with leg either at front or rear.

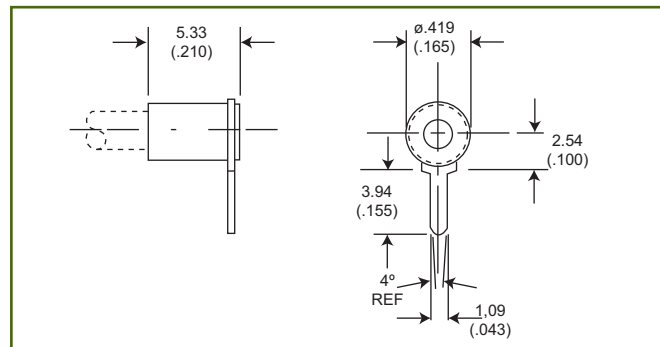

Assembled with leg at front. Mounting Plan R (Page 40)

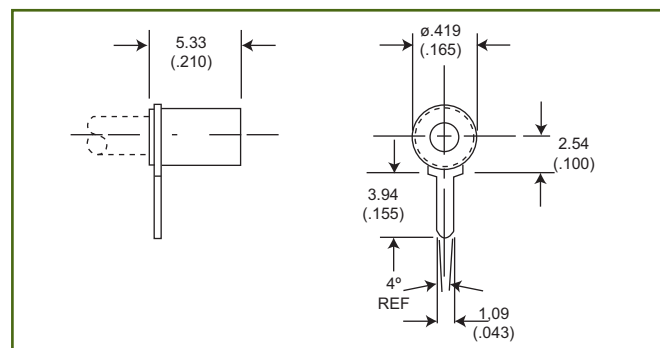

Assembled with leg at rear. Mounting Plan S (Page 40)

Assembly Instructions  
BBAI-1203 (Page 53)

**TERMINATORS**

Two Legs at Front, Standard

| Part Number         | Cable Numbers                |
|---------------------|------------------------------|
| 055 - 939 - 9039AR6 | RG178/U, 196/U               |
| 055 - 939 - 9049AR6 | RG174/U, 179/U, 188/U, 316/U |

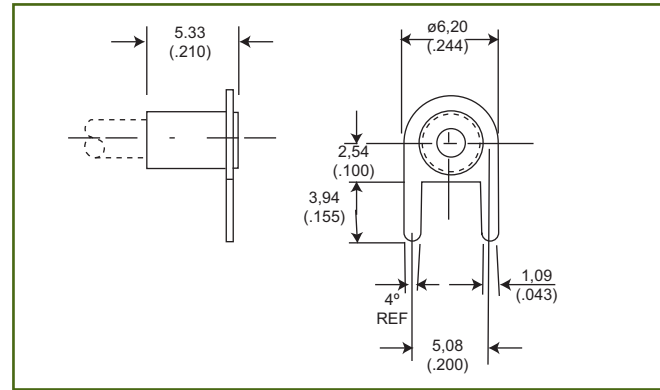

Mounting Plan T (Page 40)  
 Assembly Instruction BBAI-1203 (Page 53)

Two Legs at Front, Surface and Vertical Mount

| Part Number         | Cable Numbers                |
|---------------------|------------------------------|
| 055 - 939 - 9059AR6 | RG178/U, 196/U               |
| 055 - 939 - 9069AR6 | RG174/U, 179/U, 188/U, 316/U |

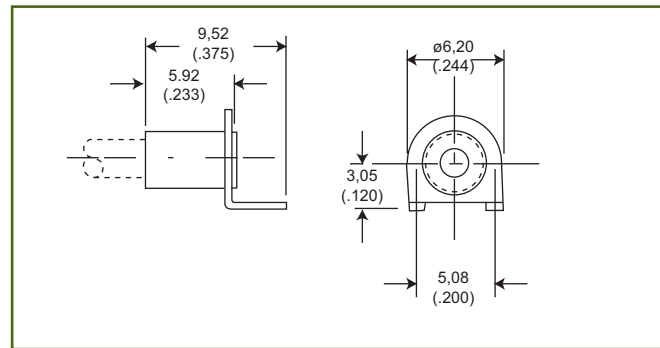

Mounting Plan T (Page 40)  
 Assembly Instruction BBAI-1203 (Page 53)

Between Series Adaptors are widely used for high efficiency transitions between various types of RF coaxial connectors. They are used for connecting test equipment to systems employing a different type connector or they are used as a component in electronic equipment where it is desirable to have one type of connector for external connections and another type for internal connections.

All Between Series Adaptors are designed for lowest VSWR characteristics up to the frequency limits of the connector types involved. All popular types of miniature, subminiature and micro-miniature designs are available.

The designs shown here are not the entire range. If you require a style not shown, please contact our Customer Service group.



**Key Features**

- Rugged construction
- Precision performance
- Low VSWR
- Ready to use - no assembly required

SMA Jack to SMC Plug

|                     |
|---------------------|
| Part Number         |
| 050 - 074 - 6201310 |

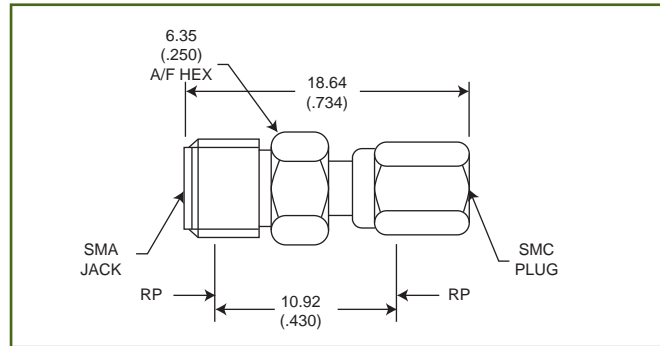

SMA Jack to SMB Plug

|                     |
|---------------------|
| Part Number         |
| 050 - 674 - 6302310 |

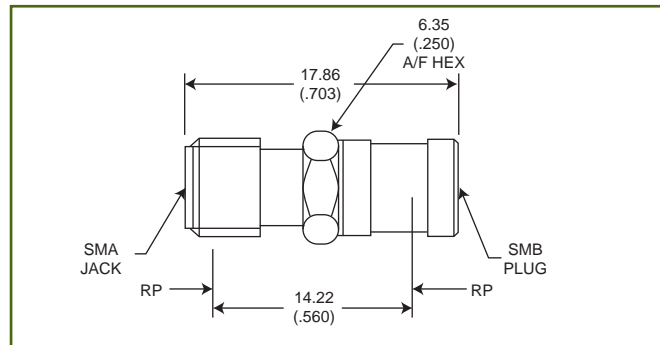

Dimensions shown in mm (inch)  
 Specifications and dimensions subject to change

SMA Slide-On Plug to SMA Standard Jack  
Adaptor - Straight (Connector Saver)

Part Number  
050 - 674 - 6324990

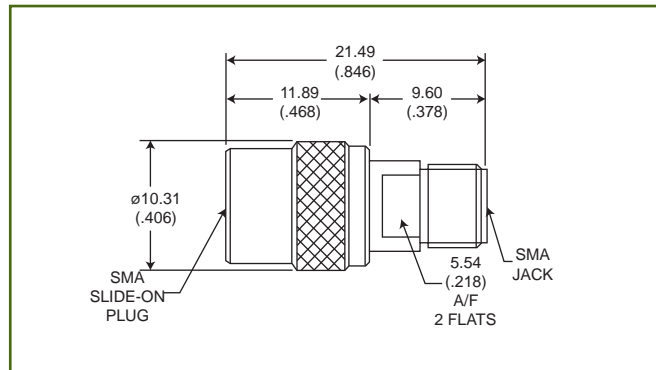

BNC Bulkhead Jack to SMA Jack

Part Number  
050 - 675 - 6801890

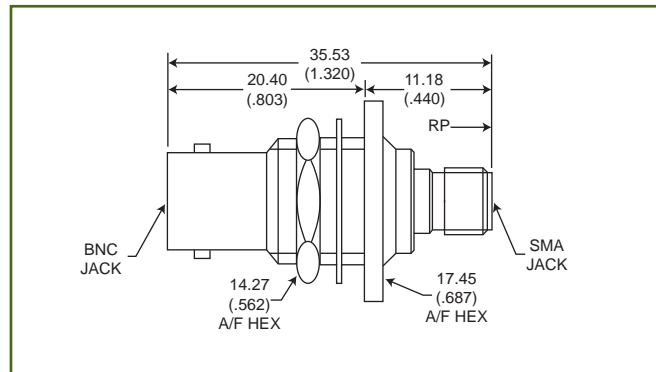

Mounting Plan Z (Page 40 ) Panel Thickness 3,18 (.125) max.

N Plug to SMA Jack

Part Number  
050 - 674 - 6700890

VSWR:  
1.10 + .01f (GHz) DC - 12.4GHz  
1.10 + .016f (GHz) 12.4 - 18 GHz

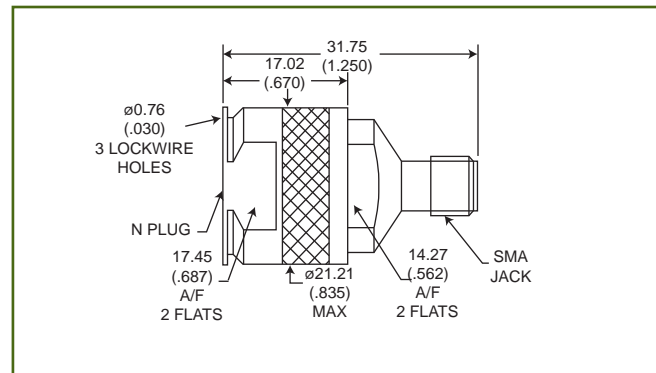

N Bulkhead Jack to SMA Jack

Part Number  
050 - 675 - 6705890

VSWR:  
1.06 + .005f (GHz) DC - 12.4GHz  
1.06 + .010f (GHz) 12.4 - 18 GHz

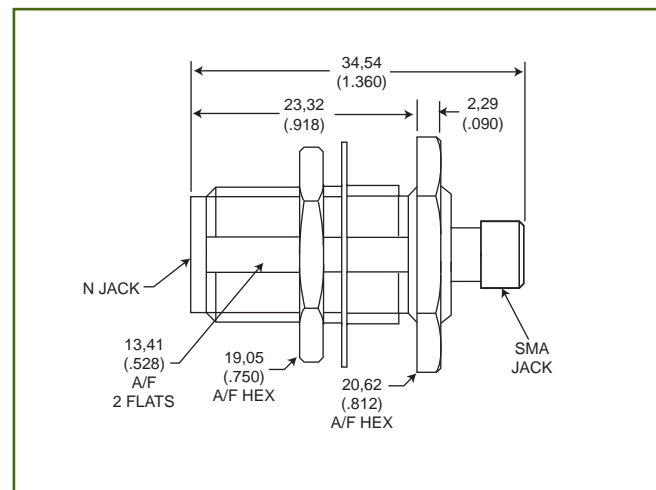

Mounting Plan GG (Page 40)  
Panel Thickness 6,35 (.250) max.

Dimensions shown in mm (inch)  
Specifications and dimensions subject to change

www.ittcannon.com

Sealflex 2 microwave cable assemblies are designed for applications requiring consistent microwave performance through to 18 GHz and may be used with minimal degradation to 26 GHz with SMA connectors.

All connector designs exhibit “mode free” characteristics to 18 GHz, thereby allowing low VSWR to be specified without “spikes” being present in the upper frequency spectrum.

Each assembly is 100% tested for VSWR and insertion loss and test plots are supplied with each item.

Sealflex 2 assemblies have been adopted for use in various avionic systems, missiles, military ground and shipborne applications as well as commercial communications equipment.

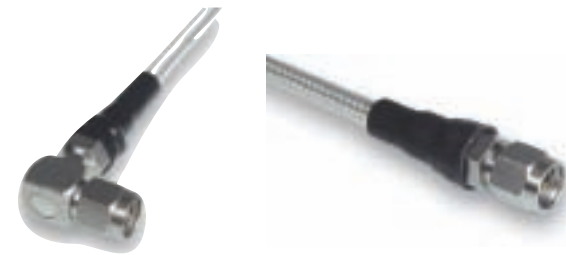

**Key Features**

- Fully flexible cable
  - Does not require detailed drawing (unlike semi-rigid)
- Triple screens (90 dB RF shielding)
- DC to 26 GHz frequency range
- 100% electrically tested
  - VSWR and insertion loss plots supplied

**SPECIFICATIONS**

|                                    |  |              |               |
|------------------------------------|--|--------------|---------------|
| <b>ELECTRICAL</b>                  |  |              |               |
| Impedance                          | 50Ω nominal  |              |               |
| Voltage Standing Wave Ratio (VSWR) | 1.25 (2 - 12.4 GHz) 1.35 (12.4 - 18 GHz)                           |              |               |
| Attenuation                        | See graph on next page   |              |               |
| Shielding RF                       | -90 dB   |              |               |
| <b>MECHANICAL</b>                  |  |              |               |
| Connector Retention                | 137 N (30.9 lbs) minimum   |              |               |
| Connector / Cable Torque           | 1.7 Nm (15 in. lbs) minimum  |              |               |
| Minimum Bend Radii                 | Cable Diameter   | Static       | Flexing       |
|                                    | 3,18 (.125)  | 13,00 (.511) | 25,00 (.984)  |
|                                    | 4,57 (.180)  | 19,00 (.748) | 38,00 (1.496) |
|                                    | 6,35 (.250)  | 25,00 (.984) | 51,00 (2.007) |
| <b>ENVIRONMENTAL</b>               |  |              |               |
| Operating Temperature              | -65°C to 165°C   |              |               |
| Moisture Resistance                | MIL-STD-202, Method 106  |              |               |
| Vibration                          | MIL-STD-202, Method 204(C)   |              |               |
| Shock                              | MIL-E-5272, Para. 4.15.5.1   |              |               |
| Thermal Shock                      | MIL-STD-202, Method 107(C)   |              |               |
| Corrosion                          | MIL-STD-202, Method 101(B)   |              |               |
| Solvent Resistance                 | 7 days at 200°C, JP6 (MIL-J-2658) and hydraulic fluid (MIL-H-5806) |              |               |

NOTES: Tighter specifications are subject to special quotation.

Attenuation

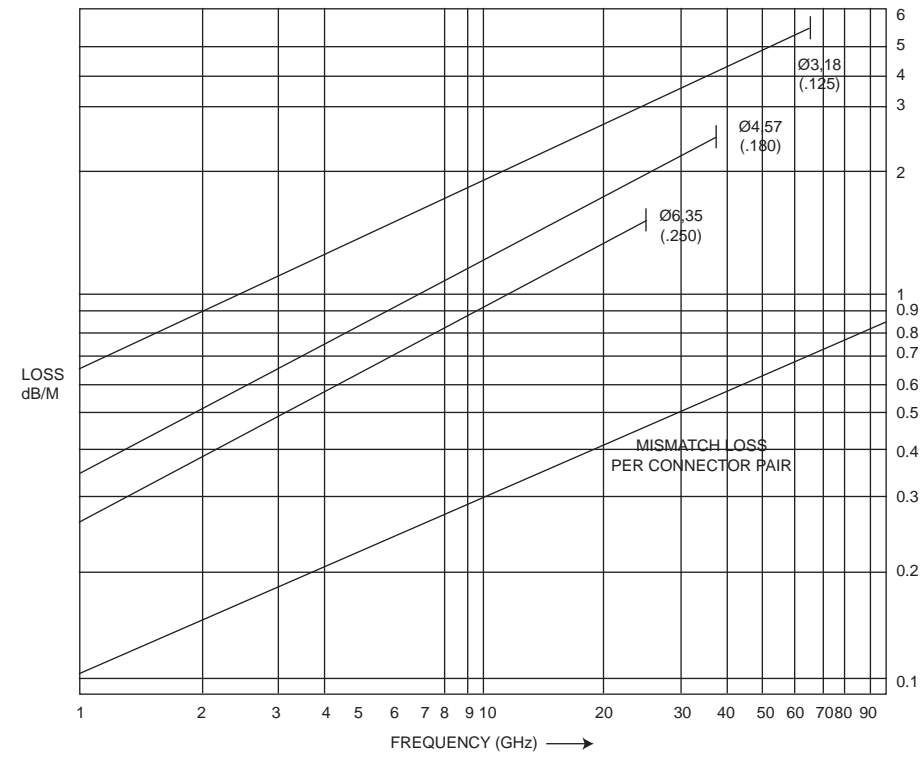

Cable Maximum Frequency ( $f_c$ ):  
 (single mode operation)

|               |            |
|---------------|------------|
| Ø 3,18 (.125) | = 65.3 GHz |
| Ø 4,57 (.180) | = 36.8 GHz |
| Ø 6,35 (.250) | = 23.7 GHz |

Typical Return Loss (VSWR) Part Number 065-9AA-1000000

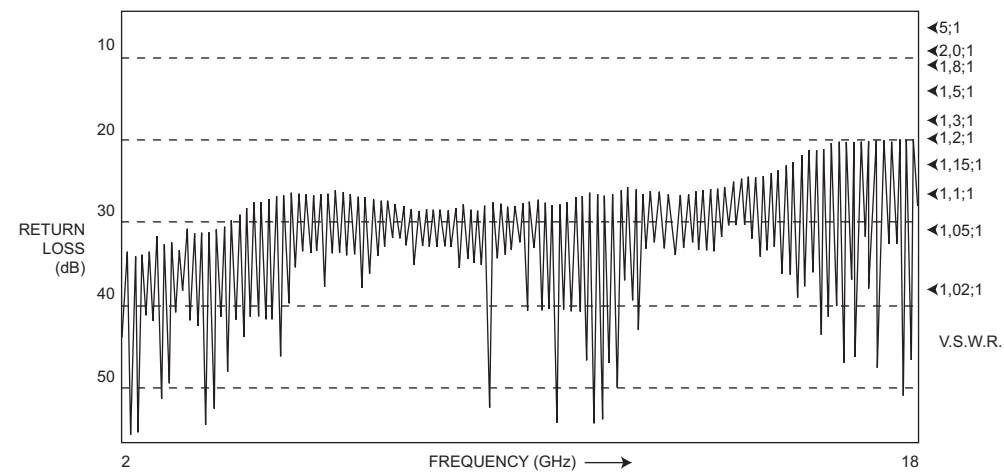

Dimensions shown in mm (inch)  
 Specifications and dimensions subject to change

www.ittcannon.com

**MICROWAVE CABLE ASSEMBLIES**

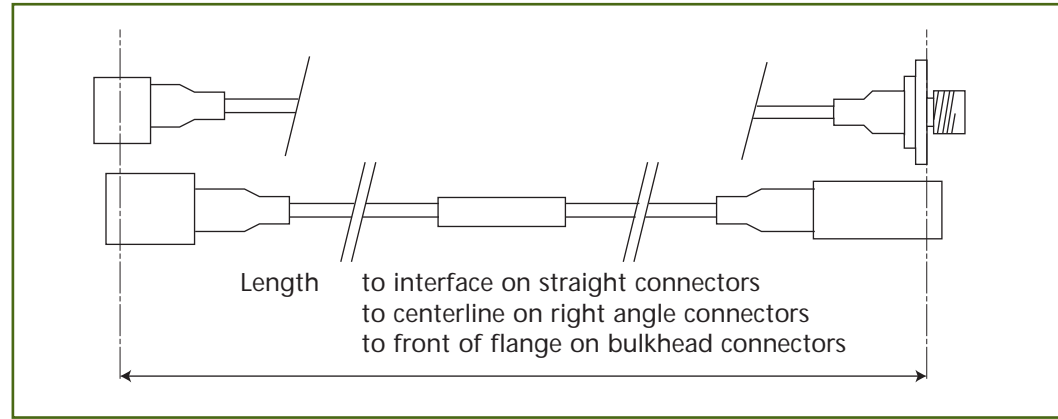

|                     |                                |                    |
|---------------------|--------------------------------|--------------------|
| Standard Tolerances | Length up to 1 m (39.370)      | -0 + 10,00 (.393)  |
|                     | 1 m (39.370) to 3 m (118.00)   | -0 + 20,00 (.787)  |
|                     | 3 m (118.00) to 15 m (1771.65) | -0 + 30,00 (1.181) |

**ORDERING INFORMATION**

This table shows how the part numbers for coaxial connectors are constructed.

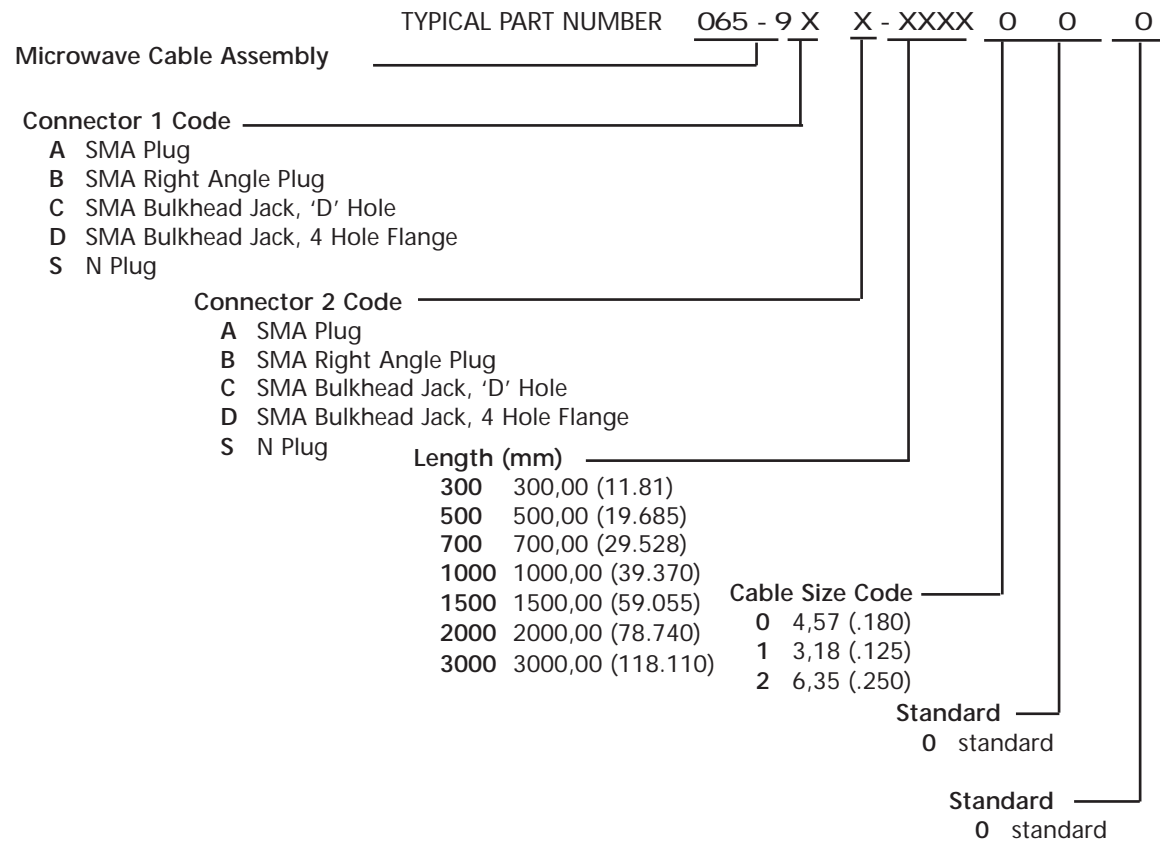

Example: 065-9AS-1000000 = Sealflex 2 cable assembly; 4,57 (.180) with 1 SMA plug and 1 N plug on 1 metre length of cable

Dimensions shown in mm (inch)  
 Specifications and dimensions subject to change



RECOMMENDED MOUNTING HOLE DIMENSIONS

| Plan | A           | B (min.) 4 positions    | C (min.) 1 position     |
|------|-------------|-------------------------|-------------------------|
| A    | 5,08 (.200) | ø 1,70/1,85 (.067/.080) | ø 1,17/1,35 (.046/.053) |
| B    | 5,08 (.200) | ø 1,30 (.051)           | ø 1,30 (.051)           |
| C    | 2,54 (.100) | ø 0,97 (.038)           | ø 0,91 (.036)           |
| D    | 5,08 (.200) | ø 1,70 (.067)           | ø 1,70 (.067)           |

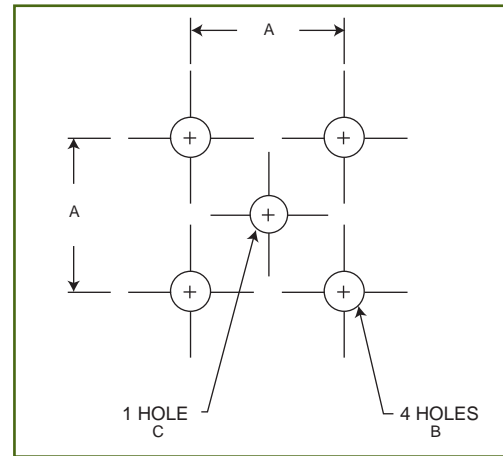

Plan A - D

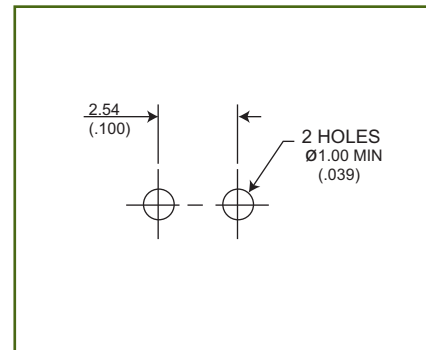

Plan R

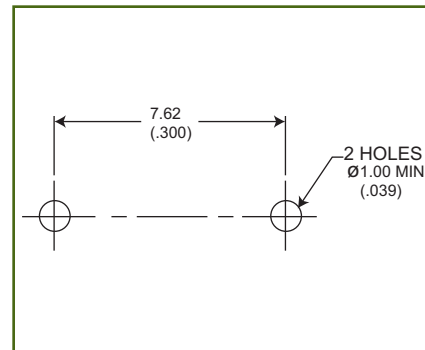

Plan S

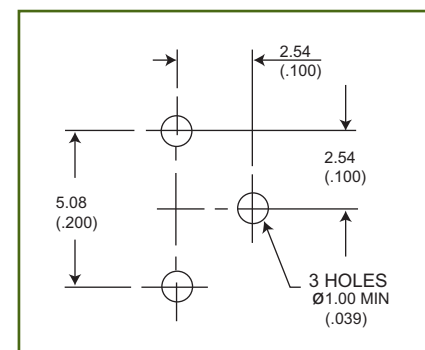

Plan T

| Plan | Thread Size    | A            | +0,13 (.005)<br>- 0,00 (.000) | B            | +0,13 (.005)<br>- 0,00 (.000) |
|------|----------------|--------------|-------------------------------|--------------|-------------------------------|
| U    | 6-40 UNF-2A    | 3,56 (.140)  |                               | 3,20 (.126)  |                               |
| V    | 10-32 UNF-2A   | 4,95 (.195)  |                               | 4,50 (.177)  |                               |
| W    | 1/4-36 UNS-2A  | 6,73 (.265)  |                               | 5,92 (.233)  |                               |
| Z    | 1/2-28 UNEF-2A | 13,08 (.515) |                               | 12,19 (.480) |                               |

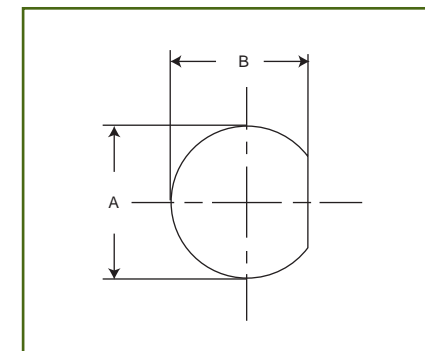

Plan U - Z

| Plan | Thread Size    | A           | +0,10 (.004)<br>- 0,03 (.001) | B           | +0,10 (.004)<br>- 0,03 (.001) |
|------|----------------|-------------|-------------------------------|-------------|-------------------------------|
| GG   | 5/8-24 UNEF-2A | 15,9 (.625) |                               | 13,5 (.531) |                               |

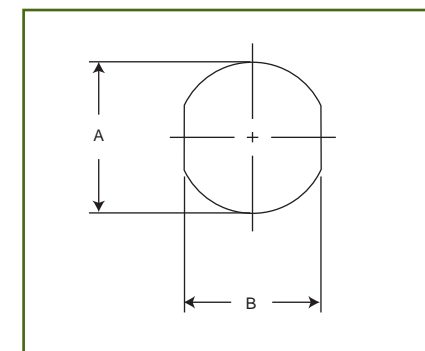

Plan GG





**AI-90 SMA Right Angle Connectors, Crimp Type for Braided Cable**

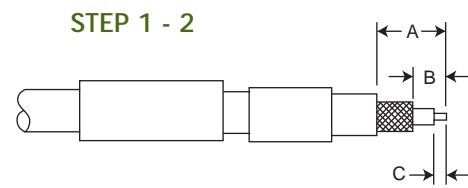
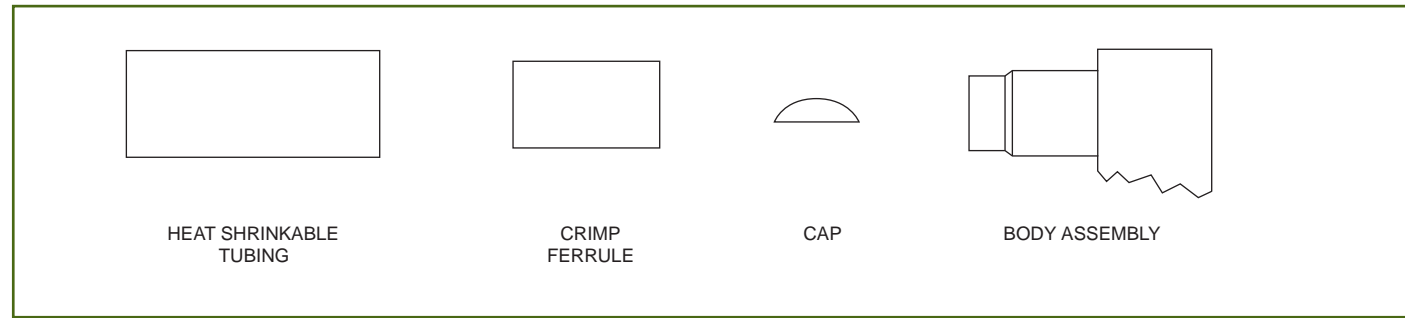

1. Slide ferrule and (if supplied) heat shrinkable tubing on to cable.
2. Trim cable to dimensions shown:

| Assembly Instruction No. | A            | B           | C           |
|--------------------------|--------------|-------------|-------------|
| AI-90                    | 11,10 (.437) | 5,16 (.203) | 1,57 (.062) |

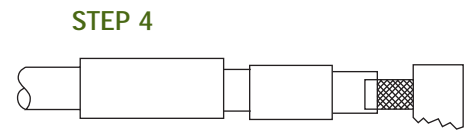

3. Tin center conductor (DO NOT OVER TIN).

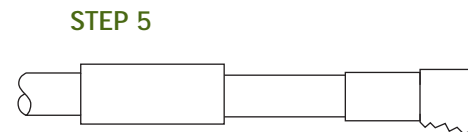

4. Slide body over cable dielectric and under the braid until braid is flush against underside of body. Ensure center conductor is located in the forked end of the contact. NOTE: When using cables with inflexible jackets it is permissible to make two 3,17 (.125) longitudinal slits in the outer jacket.

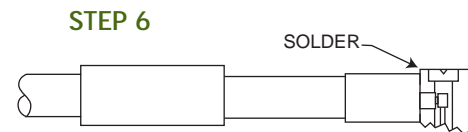

5. Slide ferrule flush against the body and crimp in position using Cannon's Crimp Tool and suitable Die Set (see table).
6. Using a small soldering iron solder center conductor to contact. NOTE: The center conductor should not protrude beyond the contact or touch the body. Solder should not protrude beyond the slotted section of the contact.

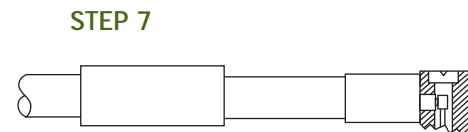

7. Locate the cap in rear of body and dimple or lightly punch to ensure it is locked in position.

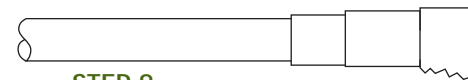

8. Slide heat shrinkable tubing over ferrule flush against body and heat until tubing shrinks down.

Only common cable retention features are shown in detail. Various body configurations can apply.

| Cable Numbers | Cable Code | Die Size    | Die Set |
|---------------|------------|-------------|---------|
| RG142/U       | 9142       | 5,42 (.213) | K29265  |
| RG196/U       | 9196       | 2,67 (.105) | K29263  |
| RG316/U       | 9188       | 3,25 (.128) | K29263  |
| RD316         | 9399/9875  | 3,84 (.151) | T1025/9 |

Dimensions shown in mm (inch)  
Specifications and dimensions subject to change

**AI-98 SMA Right Angle Connectors, Direct Solder Type for Semi-Rigid Cable**

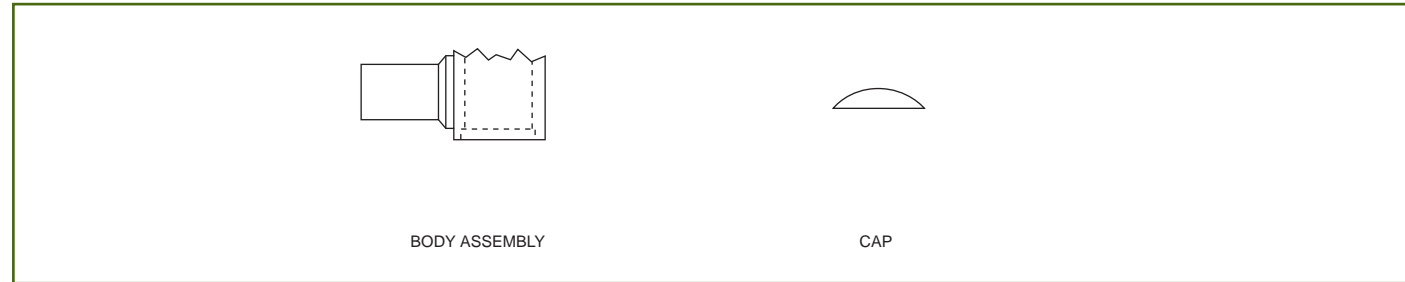

**STEP 1**

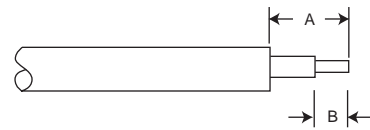

1. Trim cable jacket, dielectric and center conductor to dimensions shown, being careful not to fracture the center conductor. Tin center conductor (DO NOT OVER TIN).

$$A = 4,75 \pm 0,13 (.187 \pm .005)$$

$$B = 2,29 \pm 0,13 (.097 \pm .005)$$

**STEP 2**

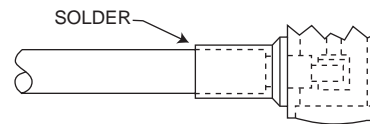

2. Slide cable into body and solder into place.

**STEP 3**

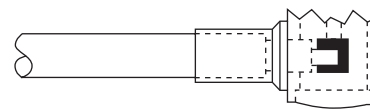

3. Solder center conductor to contact (do not over solder), then locate the cap in rear of body and dimple or lightly punch to ensure it is locked in position.

**AI-102 & AI-236 SMA Straight Connectors, Crimp Type for Braided Cable**

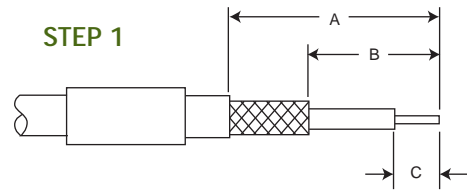
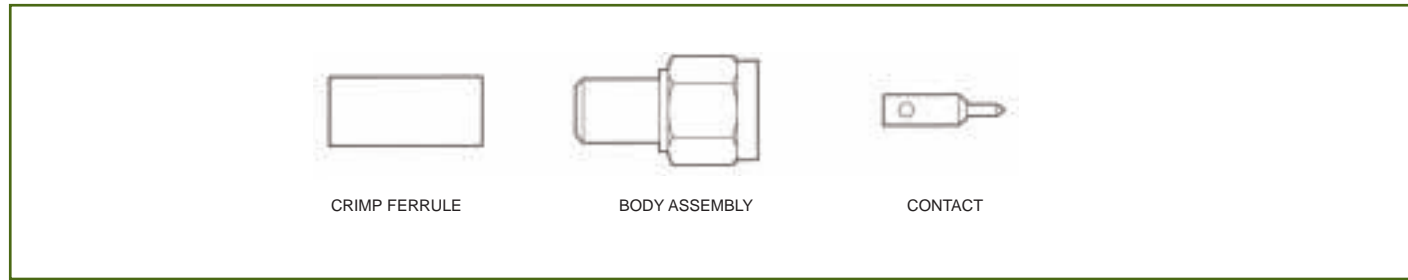

1. Trim cable to dimensions shown being careful not to nick the braid or center conductor. Tin center conductor, (DO NOT OVER TIN) then slip ferrule (and shrink tubing if supplied) over cable.

| Assembly Instruction No. | A            | B           | C           |
|--------------------------|--------------|-------------|-------------|
| AI-102 & AI-236          | 10,31 (.406) | 4,37 (.172) | 2,77 (.109) |

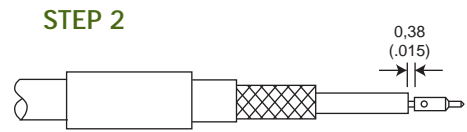

2. Solder center conductor to contact. With AI-102 and AI-236 the gap shown is to be maintained.

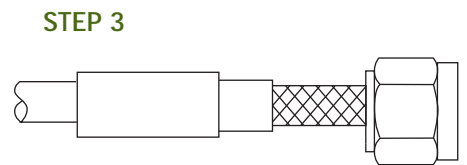

3. Insert trimmed cable into the rear of the body assembly. Tubular body extension will slide under the braid with the rear portion of extension fitting under the jacket as shown. NOTE: When using cables with inflexible jackets it is permissible to make two 3,17 (.125) long longitudinal slits in the outer jacket.

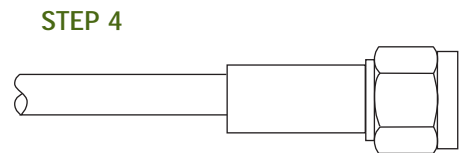

4. Slide ferrule flush against the body and crimp in position using Cannon's Crimp Tool and suitable Die Set (see table).

| Cable Numbers | Cable Code | Die Size    | Die Set |
|---------------|------------|-------------|---------|
| RG141/U       | 9141       | 5,42 (.213) | K29265  |
| RG142/U       | 9142       | 5,42 (.213) | K29265  |
| RG188/U       | 9188       | 3,25 (.128) | K29263  |
| RG196/U       | 9196       | 2,67 (.105) | K29263  |
| RD316         | 9399/9875  | 3,84 (.151) | T1025/9 |

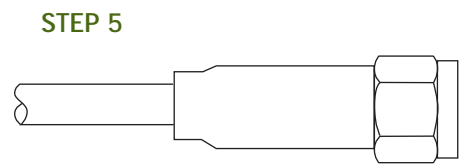

5. Slide heat shrinkable tubing over ferrule and apply heat until tubing shrinks down.

**AI-128 & AI-663 SSMB / SSMC Straight Connectors, Crimp Type for Braided Cable**

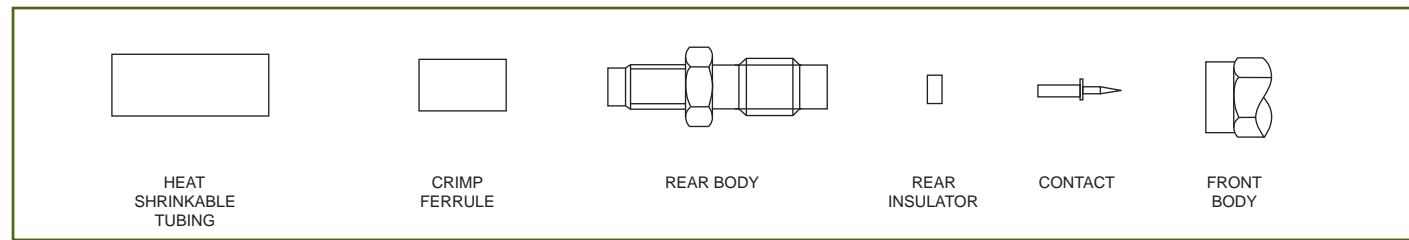

**STEP 1**



1. Slide heat shrinkable tubing and ferrule on to cable.

**STEP 2**

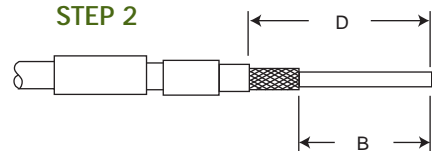

2. Trim cable to dimensions shown:

| Assembly Instruction No.                               | B           | C           | D            |
|--|-------------|-------------|--------------|
| AI-663   | 6,86 (.270) | 2,29 (.090) | 10,41 (.410) |
| AI-128 for center conductors $\varnothing 0.51$ (.020) | 6,76 (.266) | 2,29 (.090) | 9,53 (.375)  |
| AI-128 for all other conductor sizes                   | 7,54 (.297) | 3,05 (.120) | 10,31 (.406) |

**STEP 3**

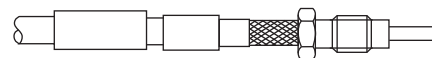

3. Slide rear body over dielectric and under the braid until braid is flush with flange. N.B. When using cable with inflexible jackets it is permissible to make two 3,00 (.118) long longitudinal slits in the outer jacket.

**STEP 4**

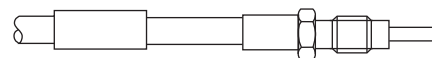

4. Slide ferrule over exposed braid up to hex. flange.  
5. Crimp using Cannon's Crimp Tool and suitable Die Set (see table). Ensure ferrule is held close to hex. flange.

**STEP 7**

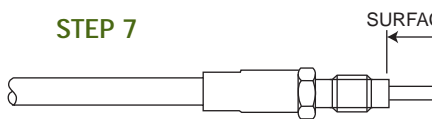

6. Slide heat shrinkable tubing over crimp and heat shrink into place using hot air gun. Air temperature should be approximately 125 °C.

**STEP 8**

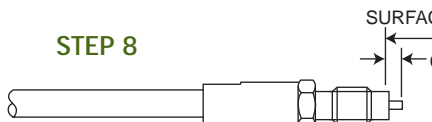

7. Trim dielectric flush with surface "A" on body using a sharp knife. Take care not to nick center conductor.

**STEP 12**

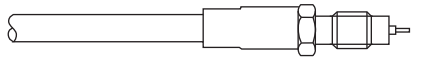

8. Trim center conductor as shown.  
9. Tin center conductor (do not allow solder to touch end of body or dielectric).  
10. Place a small solder preform made from 0,26 - 0,31 (.010 - .012) dia. (28 swg) multi-core solder in rear of contact.

**STEP 14**

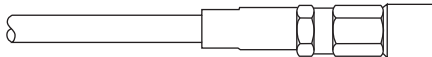

11. Place rear insulator over center conductor. When insulator has counterbore, the contact fits into the counterbore.  
12. Assemble contact onto center conductor, heat to make solder connection. Do not allow solder to protrude outside spill hole.  
13. Solder should be visible at inspection hole, if excess solder runs from inspection hole, remove with sharp blade taking care not to damage plating.  
14. Screw on the front body and tighten to a torque of 0.14Nm (20 in. ozs)

Only common cable retention features are shown in detail. Various body configurations can apply.

| Cable Numbers | Cable Code | Die Size    | Die Set |
|---------------|------------|-------------|---------|
| RG196/U       | 3196       | 2,67 (.105) | K29263  |
| RG316/U       | 3188       | 3,25 (.128) | K29263  |
| RD316         | 3875       | 3,84 (.151) | T1025/9 |

**AI-129, AI-286 & AI-696 SSMB / SSMC Right Angle Connectors, Crimp Type for Braided Cable**

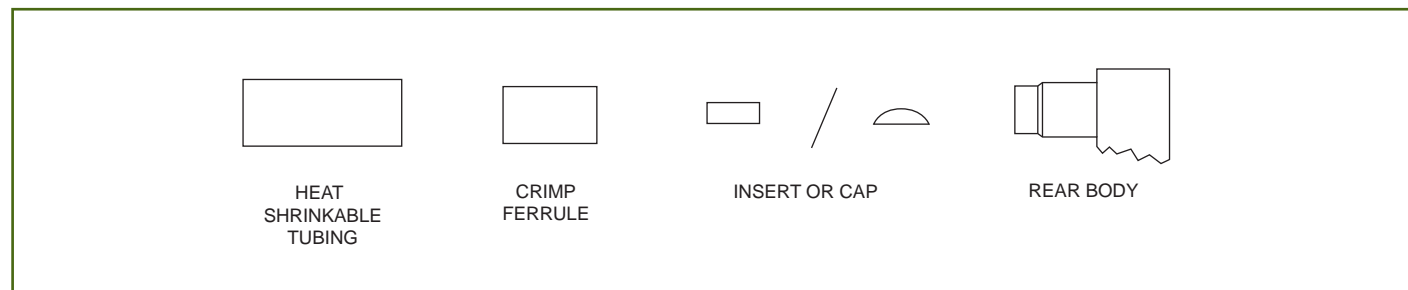

1. Slide heat shrinkable tubing and ferrule on to cable.
2. Trim cable to dimensions shown:

**STEP 1-2**

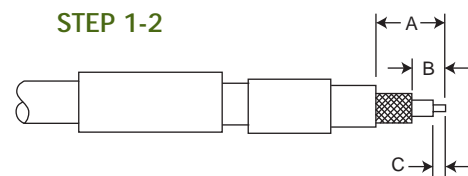

| Assembly Instruction No. | A           | B           | C           |
|--------------------------|-------------|-------------|-------------|
| AI-129                   | 5,56 (.219) | 2,77 (.109) | 1,19 (.047) |
| AI-286                   | 6,35 (.250) | 2,77 (.109) | 0,79 (.031) |
| AI-696                   | 6,22 (.245) | 2,54 (.100) | 1,14 (.045) |

**STEP 4**

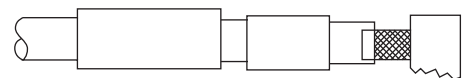

3. Tin center conductor. (DO NOT OVER TIN).
4. Slide body over cable dielectric and under the braid until braid is flush against underside of rear body. Ensure center conductor is located in the forked end of the contact. NOTE: When using cables with inflexible jackets it is permissible to make two 3,00 (.118) longitudinal slits in the outer jacket.

**STEP 5**

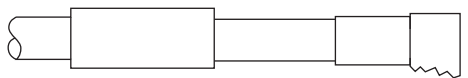

5. Slide ferrule flush against the body and crimp in position using Cannon's Crimp Tool and suitable Die Set (see table).
6. Using a small soldering iron solder center conductor to contact. NOTE: The center conductor should not protrude beyond the contact or touch the body. Solder should not protrude beyond the slotted section of the contact.

**STEP 6**

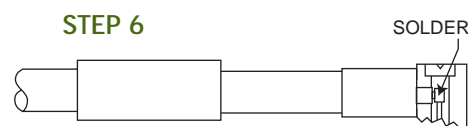

7. Press insert into place or locate the cap in rear of body and dimple or lightly punch to ensure it is locked into position (recommended tool, flat pin  $\phi$  3,07 +/- 0,05) (.121 +/- .002).

**STEP 7**

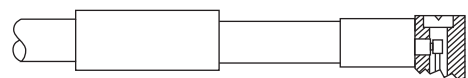

8. Slide heat shrinkable tubing over ferrule flush against body and heat until tubing shrinks down.

**STEP 8**

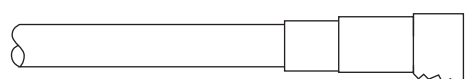

| Cable Numbers | Cable Code | Die Size    | Die Set |
|---------------|------------|-------------|---------|
| RG196/U       | 3196       | 2,67 (.105) | T1025/1 |
| RG316/U       | 3188       | 3,25 (.128) | T1025/4 |
| RD316         | 3875       | 3,84 (.151) | T1025/9 |

Only common cable retention features are shown in detail. Various body configurations can apply.

**AI-227 SMA Straight Connectors, Crimp Type for Braided Cable, Captive Contact**

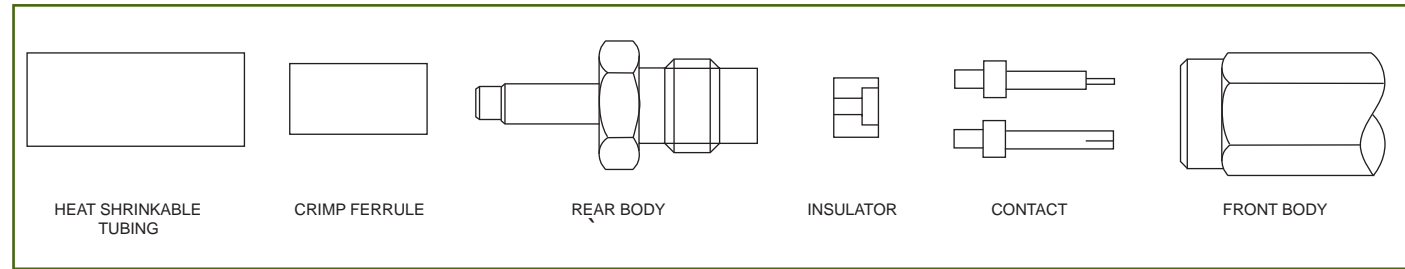

1. Slide ferrule and heat shrinkable tubing on to cable.

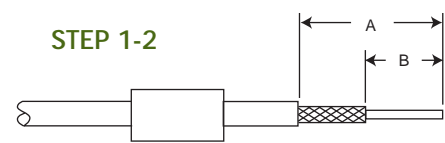

2. Trim cable to dimensions shown:

| A            | B           | C           |
|--------------|-------------|-------------|
| 15,00 (.590) | 9,00 (.354) | 3,00 (.118) |

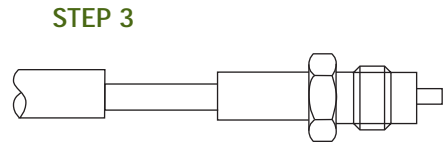

3. Slide body over cable dielectric and under the braid until the braid is flush against the rear of the hexagonal nut. NOTE: When using cables with inflexible jackets, it is permissible to make two 3,17 (.125) longitudinal slits in the outer jacket.

4. Slide ferrule flush against the body and crimp in position using Cannon's Crimp Tool and suitable Die Set (see table).

5. Trim back dielectric and center conductor to dimensions shown.

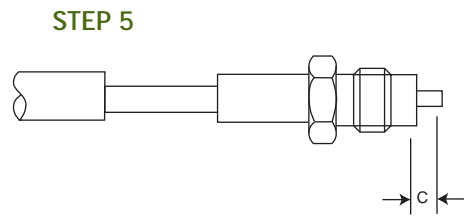

6. Tin center conductor (DO NOT OVER TIN).

7. Assemble insulator over center conductor with counterbore in direction shown.

8. Place a small solder preform made from 0,26 - 0,31 (.010 - .012) dia.(28 swg) multi-core solder in rear of contact.

9. Assemble contact on center conductor, heat to make solder connection ensuring shoulder of contact is flush against rear insulator. Do not allow solder to protrude outside spill hole.

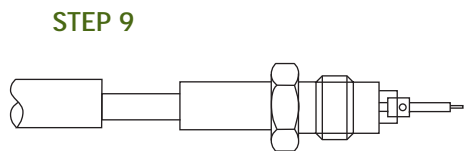

10. Insert crimped assembly into back end of body and tighten to a torque of 0.70 - 0.80 Nm (100-110 in. ozs.).

11. Slide heat shrinkable tubing over ferrule and apply heat until tubing shrinks down.

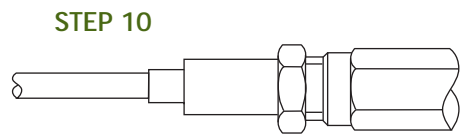

| Cable Numbers | Cable Code | Die Size    | Die Set |
|---------------|------------|-------------|---------|
| RG142/U       | 3196       | 2,67 (.105) | K29263  |
| RG316/U       | 3188       | 3,25 (.128) | K29263  |
| RD316         | 3875       | 3,84 (.151) | T1025/9 |



**AI-252 & AI-278 SMA Straight Connectors, Direct Solder (Separate Center Contact) Type for Semi-Rigid Cable**

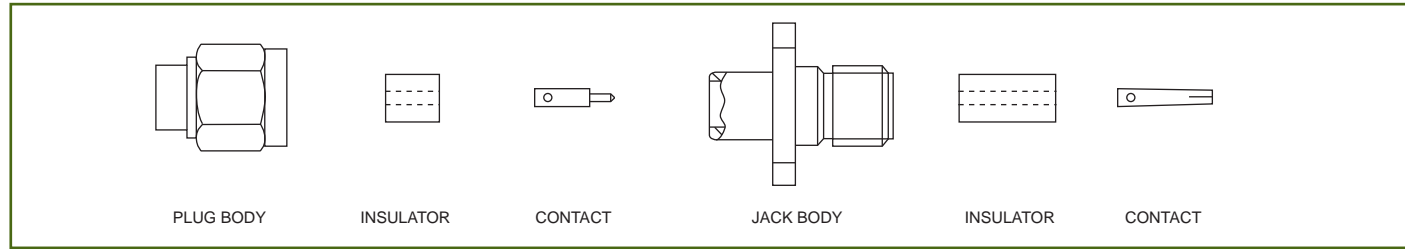

**STEP 1 - 2**

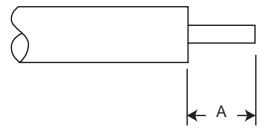

1. Cut cable end square. Trim the cable outer conductor and dielectric as shown taking care not to nick the center conductor. Deburr outer conductor at point of cut.

| Assembly Instruction No |      | Configuration |                 | A    | B      |
|-------------------------|------|---------------|-----------------|------|--------|
| AI-252                  | Plug | 3,18 +/- 0,25 | (.125 +/- .010) | 0,38 | (.015) |
| AI-278                  | Jack | 2,54 +/- 0,25 | (.100 +/- .010) | 0,38 | (.015) |

**STEP 3**

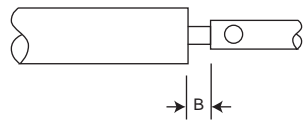

2. Tin center conductor (DO NOT OVER TIN).
3. Solder contact to center conductor ensuring that dimension shown is maintained. Remove any excess solder.

**STEP 5**

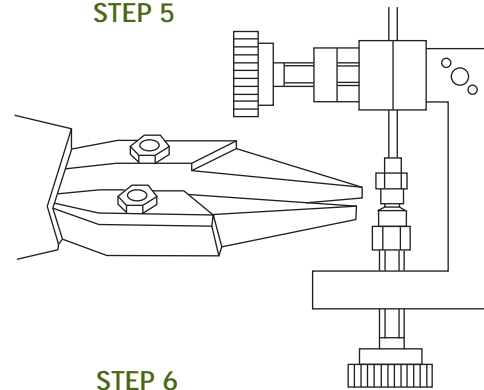

4. Clean housing area of outer conductor with abrasive paper and clean in a suitable agent.
5. Place connector assembly in Assembly Jig T1848, or other suitable clamping arrangement, with contact in locator tool as shown.

Tighten screw to secure cable between inserts then tighten locator to seat cable firmly. Place solder ring around cable adjacent to connector body and heat the connector body using an appropriate heat source (solder tongs with variable control). Apply sufficient heat for solder to flow but using minimum heat cycle.

**STEP 6**

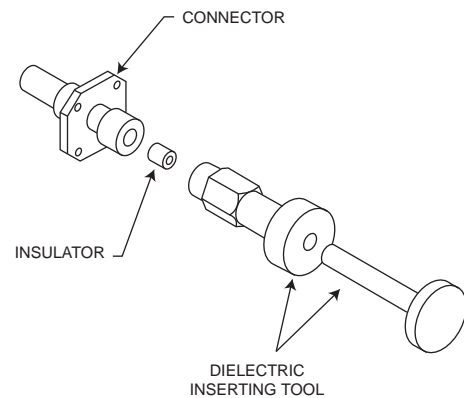

6. Using dielectric insertion Tool T2508 (for plugs) or T2509 (for jacks), press insulator into body. Assembly is now ready for use.

N.B. Various body configurations can apply.

Dimensions shown in mm (inch)  
Specifications and dimensions subject to change

www.ittcannon.com



**AI-302 SMA Straight Connectors, Direct Solder (Cable Conductor used as Center Contact) Type for Semi-Rigid Cable**

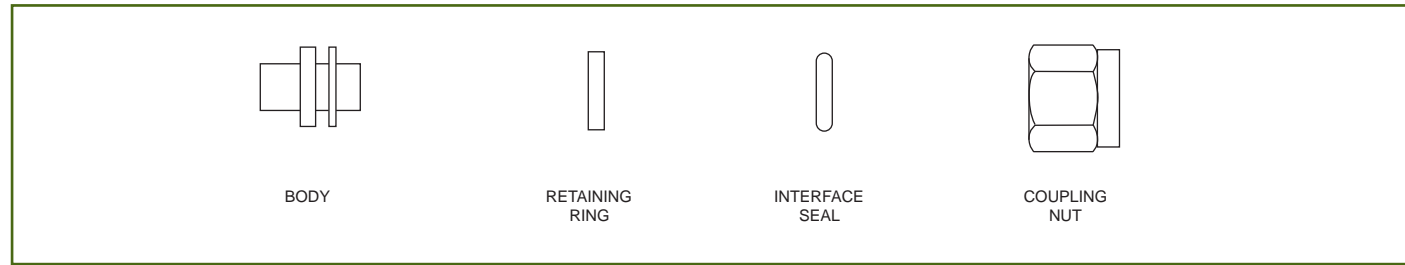

**STEP 1**

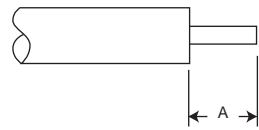

1. Trim the cable outer conductor and dielectric as shown taking care not to nick the center conductor. Deburr outer conductor at point of cut.

$$A = 2,16 \pm 0,13 \text{ (.085 } \pm \text{ .005)}$$

**STEP 2**

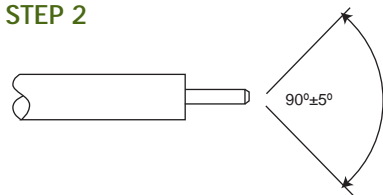

2. Point the end of the center conductor using a miniature file.
3. If style - 9073 is being assembled slip the coupling nut onto the cable.

**STEP 4**

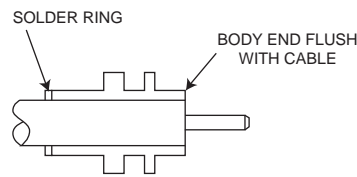

4. Clean housing area of outer conductor with abrasive paper and clean in a suitable agent. Place 24 s.w.g. soldering ring and connector body on prepared end of cable. Ensure body is correct way round. End of cable to be flush with end of connector body as shown.

**STEP 5**

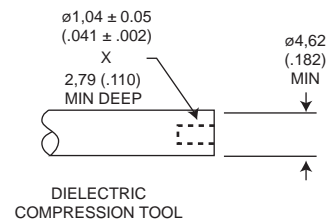

5. Compress expanded dielectric back into cable outer conductor with Dielectric Compression Tool as shown, until it is flush with end of body and outer conductor.
6. Fit the interface seal.
7. Install the spring retaining ring, compress with Tool T0557/1 and fit the coupling nut.





**BAI-015 SMB Right Angle Connectors, Crimp Type for Braided Cable**

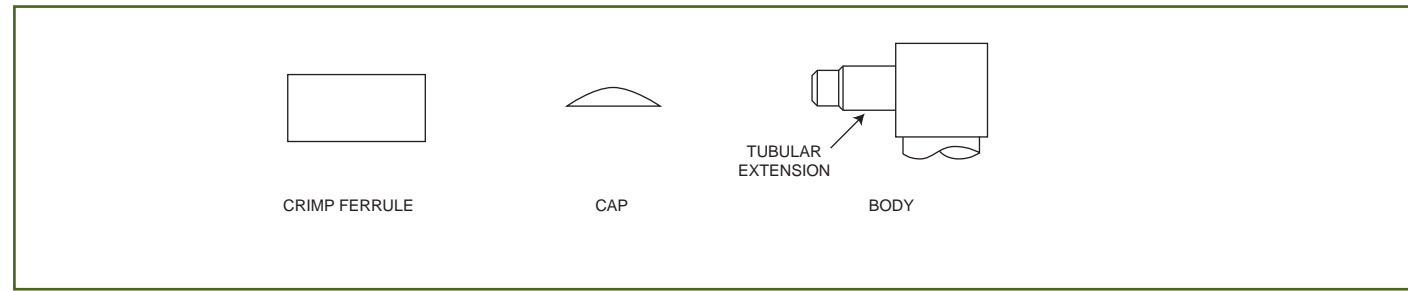

**STEP 1**

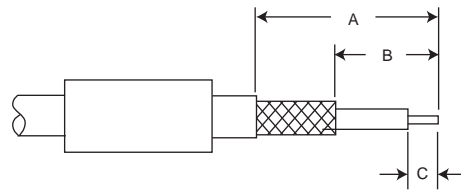

1. Trim cable to dimensions shown taking care not to nick braid or center conductor. Tin center conductor (DO NOT OVER TIN) then slip crimp ferrule over cable.

| Assembly Instruction No. | A            | B           | C           |
|--------------------------|--------------|-------------|-------------|
| BAI-015                  | 10,00 (.393) | 4,00 (.157) | 1,50 (.059) |

**STEP 2**

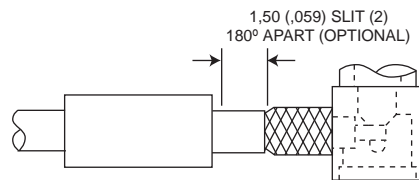

2. Insert trimmed cable into back end of body. The tubular body extension will slide under the braid with the rear portion of extension fitting under the jacket as shown. The center conductor will extend into slot in contact.  
NOTE: On smaller diameter cables, two longitudinal slits in the jacket, 180° apart, may be cut to ease assembly.

**STEP 3**

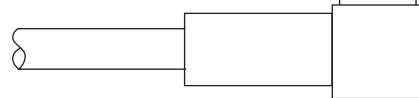

3. Slip ferrule up over braid to face of square body and crimp, using Cannon's Crimp Tool and suitable Die Set (see table).

| Cable Numbers | Cable Code | Die Size    | Die Set |
|---------------|------------|-------------|---------|
| RG142/U       | 9052       | 5,41 (.213) | K29265  |
| RG196/U       | 3196       | 2,67 (.105) | K29263  |
| RG316/U       | 0000       | 3,25 (.128) | K29263  |
| RG316/U       | 3188       | 3,25 (.128) | K29263  |
| RD316         | 9399       | 3,84 (.151) | T1025/9 |

4. Using a small soldering iron solder center conductor to contact. NOTE: The center conductor should not protrude beyond the contact to touch the body. Solder should not protrude beyond the slotted section of the contact.
5. Locate the cap in rear of body and dimple or lightly punch to ensure it is locked in position. (A flat punch is recommended). SUPPORT BODY ON SHOULDER DURING THIS OPERATION.

Only common cable retention features are shown in detail. Various body configurations can apply.

**BAI-003 SMB / SMC Straight Connectors, Crimp Type for Braided Cable**

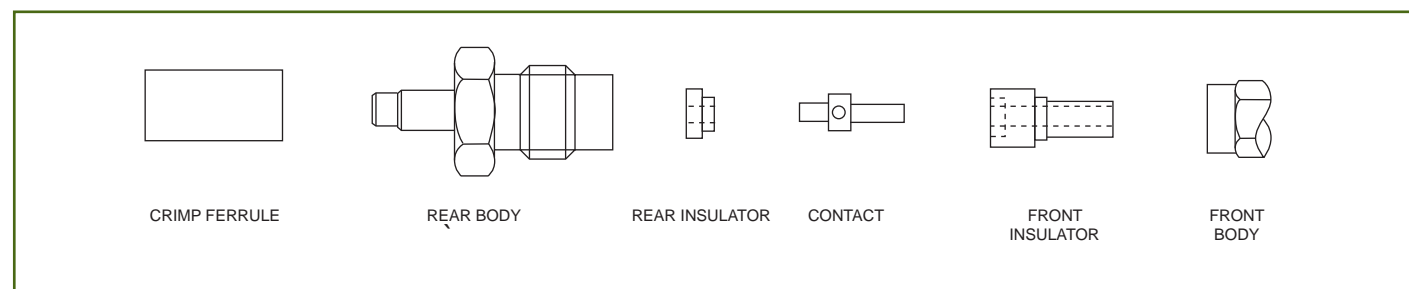

**STEP 1**

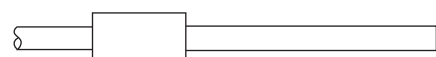

1. Slide ferrule on cable.
2. Trim cable to dimensions shown taking care not to nick braid or center conductor.

**STEP 2**

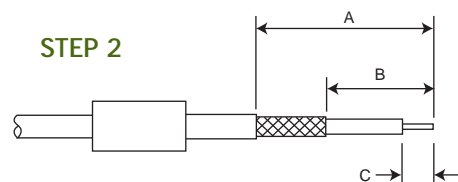

| Assembly Instruction No. | A            | B           | C           |
|--------------------------|--------------|-------------|-------------|
| BAI-003                  | 15,50 (.610) | 9,50 (.374) | 2,50 (.098) |

**STEP 4**

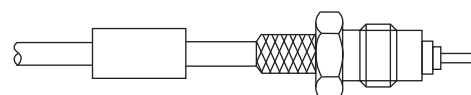

3. Tin center conductor (DO NOT OVER TIN).
4. Slide rear body over cable dielectric and under the braid until the braid is flush against the rear of the hexagonal nut. NOTE: When using cables with inflexible jackets two 3,17 (.125) slits in the outer jacket are permissible.
5. Slide on rear insulator so that the counterbore rests against the cable dielectric.
6. Place a small solder preform made from 0,26 - 0,31 (.010 - .012) dia (28 swg) multi-core solder in rear of contact.

**STEP 5**

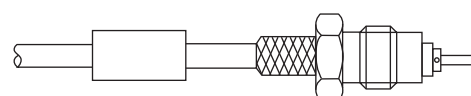

7. Assemble contact on center conductor, heat to make solder connection ensuring shoulder of contact is flush against rear insulator. NOTE: Do not allow solder to protrude outside spill hole.
8. Slide ferrule against body and crimp using Cannon's Crimp Tool and suitable Die Set (see table below).

**STEP 7**

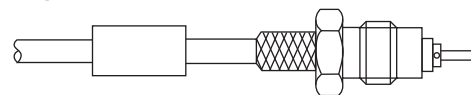

9. Slide on front insulator (if not already assembled in body).
10. Screw on front body and tighten to 0,63 - 0,70 Nm (90 - 100 in. ozs.)

Only common cable retention features are shown in detail. Various body configurations can apply.

**STEP 8**

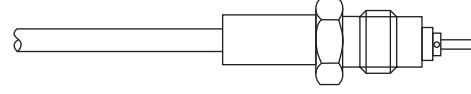

| Cable Numbers | Cable Code | Die Size    | Die Set |
|---------------|------------|-------------|---------|
| RG142/U       | 9052       | 5,41 (.213) | K29265  |
| RG196/U       | 3196       | 2,67 (.105) | K29263  |
| RG316/U       | 0000       | 3,25 (.128) | K29263  |
| RD316         | 9399       | 3,84 (.151) | T1025/9 |

**STEP 10**

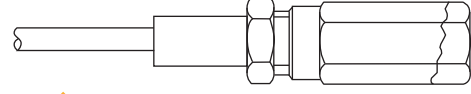

**AI-703 SMA Straight Connectors, Captive Contact, Crimp Type for Braided Cable**

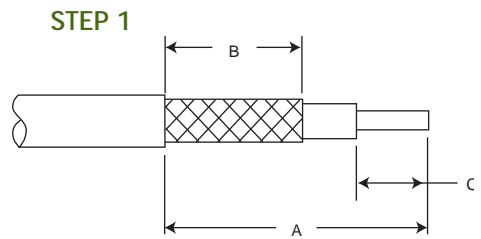
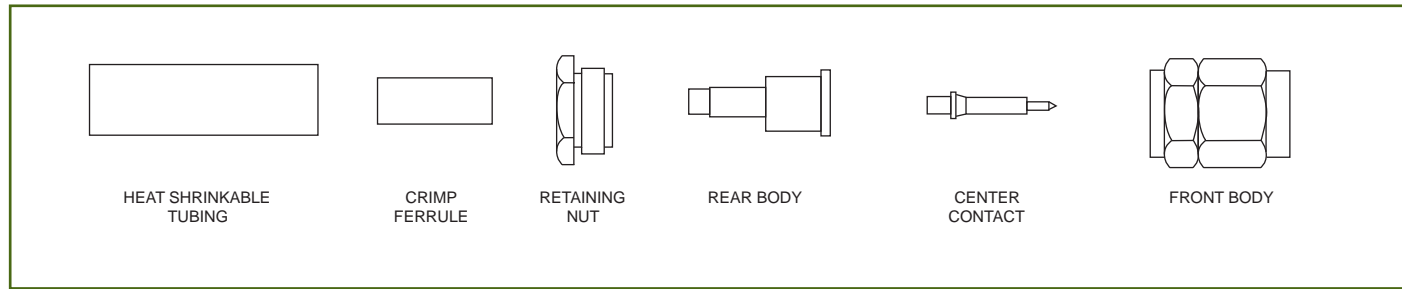

1. Strip cable to dimensions shown. Do not nick outer or inner conductors. Tin inner conductor.

| A            | B           | C           |
|--------------|-------------|-------------|
| 13,46 (.530) | 7,11 (.280) | 3,56 (.140) |

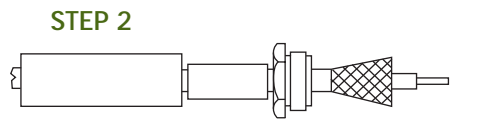

2. Place shrink tubing, crimp ferrule and retaining nut on cable. Flare the cable outer conductor as shown.

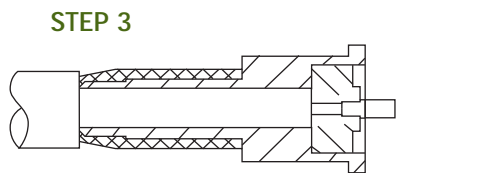

3. Insert cable dielectric into rear body until it bottoms firmly against insulator as shown.

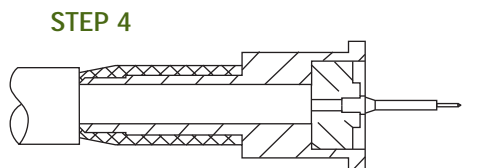

4. Place a 0,38 (.015) dia. X 2,50 +/- 0,51 (.100 +/- .020) long solder wire into solder hole of the center contact. Heat center contact and push it over cable inner conductor until it bottoms against insulator as shown. Remove excess solder if necessary.

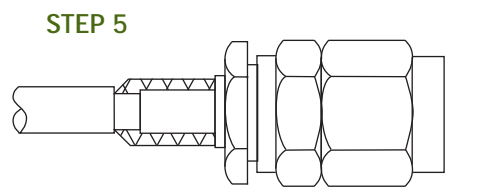

5. Insert rear body into front body. Engage threads of retaining nut to front body and hand tighten retaining nut. Hold front body firmly with a 7,93 (.312) hex. torque wrench and torque it to 1,13 - 1,69 Nm (10-15 in. lbs) by turning retaining nut only.

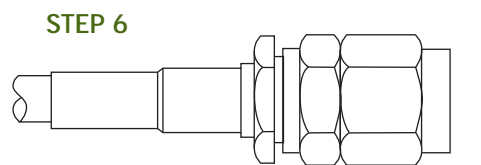

6. Slide crimp ferrule over flared portion of cable outer conductor. Crimp outer sleeve in place as shown. Push cable firmly toward connector when crimping. Trim and remove any excess outer conductor strands if necessary. Position shrink tubing over crimp sleeve apply indirect heat to shrink tubing down.

| Cable Numbers | Cable Code | Die Size    | Die Set |
|---------------|------------|-------------|---------|
| RG142/U       | 9142       | 5,41 (.213) | K29265  |
| RG316/U       | 9188       | 3,25 (.128) | K29263  |
| RD316         | 9875       | 3,84 (.151) | T1025/9 |

Dimensions shown in mm (inch)  
Specifications and dimensions subject to change

www.ittcannon.com



**BAI-001 SMB / SMC Straight Connectors, Clamp Type for Braided Cable**

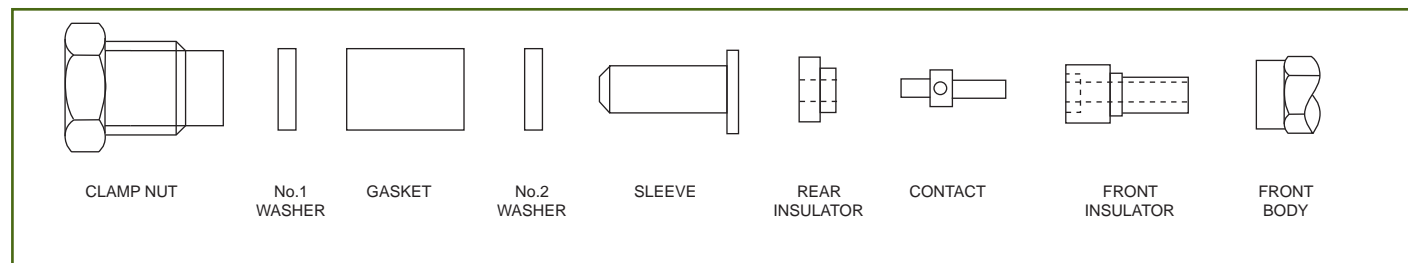

**STEP 1**

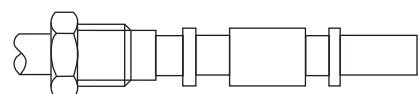

1. Slide clamp nut, No.1 washer, gasket and No.2 washer over cable.

**STEP 2**

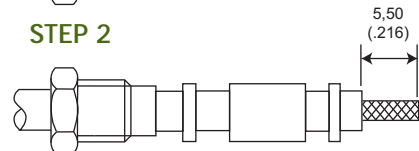

2. Trim cable to dimension shown taking care not to nick the braid.

**STEP 3**

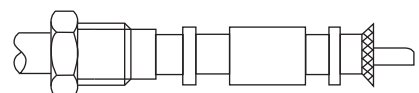

3. Thumb braid out radially at right angles to dielectric.

**STEP 5**

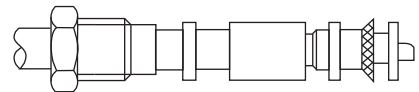

4. A small chamfer may now be cut on the end of cable dielectric, to assist assembly of sleeve.

5. Slide sleeve over cable dielectric and under braid and outer jacket until the flange of the sleeve is flush against the braid.

6. Move No. 2 washer up to braid and trim braid flush with the flange of the sleeve.

**STEP 7**

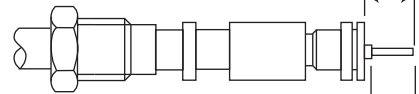

7. Trim cable dielectric and center conductor to dimensions shown taking care not to nick the center conductor.

**STEP 9**

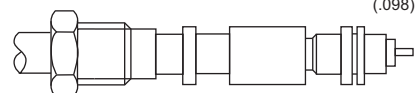

8. Tin center conductor (DO NOT OVER TIN).

9. Slide rear insulator over cable.

10. Place a small solder preform made from 0,26 - 0,31 (.010 - .012) dia (28 swg) multi-core solder in rear of contact.

11. Push contact on center conductor as far as possible. Heat center conductor and push until the shoulder of the contact is flush against the rear insulator. Do not allow solder to protrude outside spill hole.

**STEP 11**

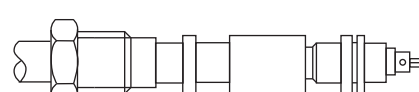

12. Slide on front insulator flush against rear insulator (if not already assembled in body).

**STEP 12**

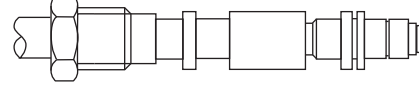

13. Move clamp nut, No.1 washer and gasket up to No. 2 washer, slide on front body and tighten clamp nut to required torque: 0,63 - 0,70 Nm (90-100 in. ozs.)

**STEP 13**

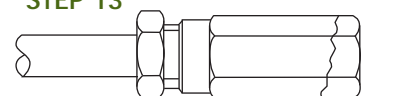

Only common cable retention features are shown in detail. Various body configurations can apply.



Dimensions shown in mm (inch)  
Specifications and dimensions subject to change

[www.ittcannon.com](http://www.ittcannon.com)

**BBAI-1203 Coaxial Terminations, 1 and 2 Point Direct PCB**

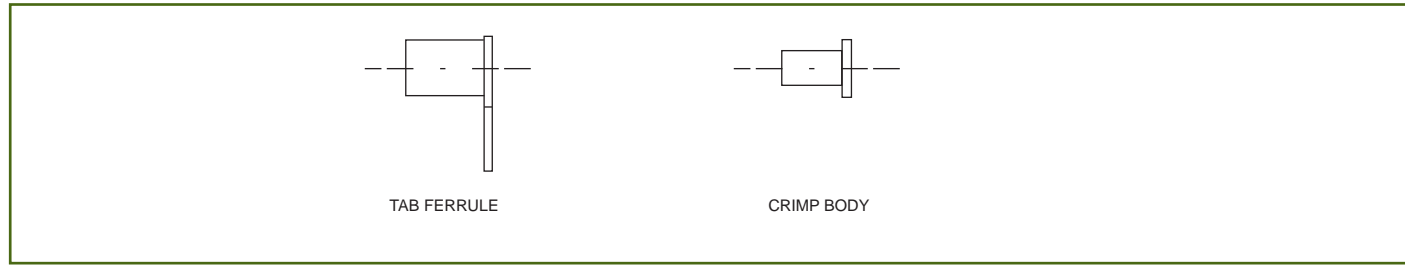

**STEP 1**

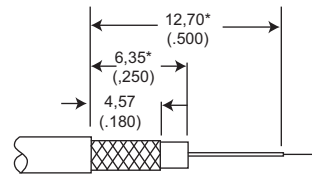

1. Trim cable to dimensions shown being careful not to nick or damage braids or center conductor. Trim center conductor. \* These dimensions suit 2,54 (.100) and 7,62 (.300) PCB pitches, for other pitches see Note 4.

**STEP 2**

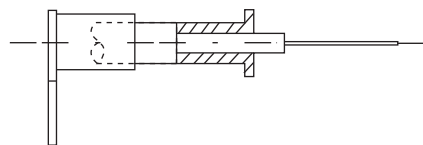

2. Slide Tab-Ferrule over cable.

NOTE: Orientation of tab-ferrule is optional depending upon mounting requirements. Flare braids and slide crimp body over cable dielectric until braids meet flange on crimp body.

**STEP 2**

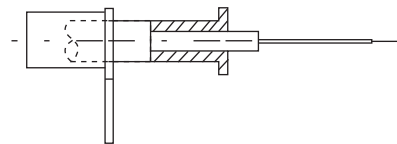

**STEP 3**

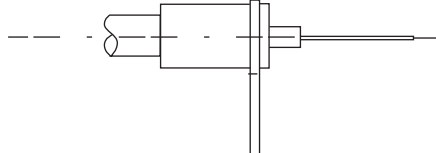

3. Slide tab-ferrule over braids to face of flange and crimp using Cannon's Crimp Tool and suitable Die Set (see table).

| Cable Numbers | Die Size    | Die Set |
|---------------|-------------|---------|
| RG174/U       | 3,25 (.128) | K29263  |
| RG178/U       | 2,67 (.105) | K29263  |
| RG179/U       | 3,25 (.128) | K29263  |
| RG188/U       | 3,25 (.128) | K29263  |
| RG196/U       | 2,67 (.105) | K29263  |
| RG316/U       | 3,25 (.128) | K29263  |

**STEP 4**

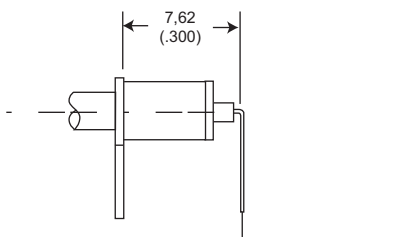

4. Bend center conductor to dimension shown depending upon preferred orientation. These dimensions suit 2,54 (.100) and 7,62 (.300) PCB pitches. For other pitches of 2,54 (.100) multiples add 2,54 (.100) multiples to the 12,70 (.500) and 6,35 (.250) dimensions in the cable stripping instructions Note 1.

**STEP 4**

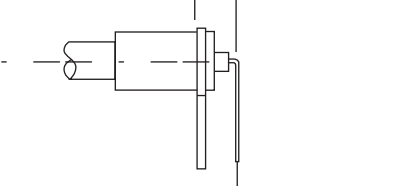

Dimensions shown in mm (inch)  
Specifications and dimensions subject to change

**CSMA 1 - SMA Straight Connectors, Crimp Type for Braided Cable**

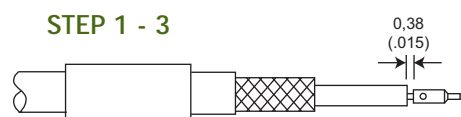
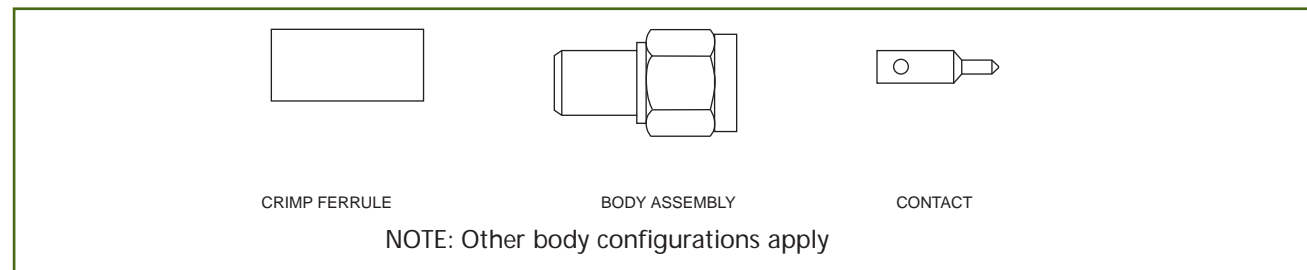

1. Slide ferrule on to cable.
2. Trim cable dimension shown next to the applicable connector drawing on page 15 or page 16.
3. Solder contact attachment:  
Solder contact to inner conductor.

Crimp contact attachment:  
Crimp contact to inner conductor using Cannon's Hand Tool T4897 with positioner T4898 (for male contacts) and T4899 (for female contacts).

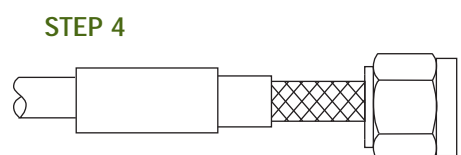

4. Insert trimmed cable into the rear of the body assembly. Tubular body extension will slide under the braid with the rear portion of extension fitting under the jacket as shown. NOTE: When using cables with inflexible jackets it is permissible to make two 3.17 (.125) long longitudinal slits in the outer jacket.

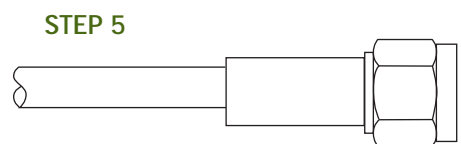

5. Slip ferrule flush against the body and crimp in position using Cannon's Crimp Tool and Suitable Die Set (see table on page 58).

**CSMA 2 - SMA Right Angle Connectors, Crimp Type for Braided Cable**

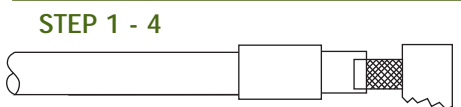
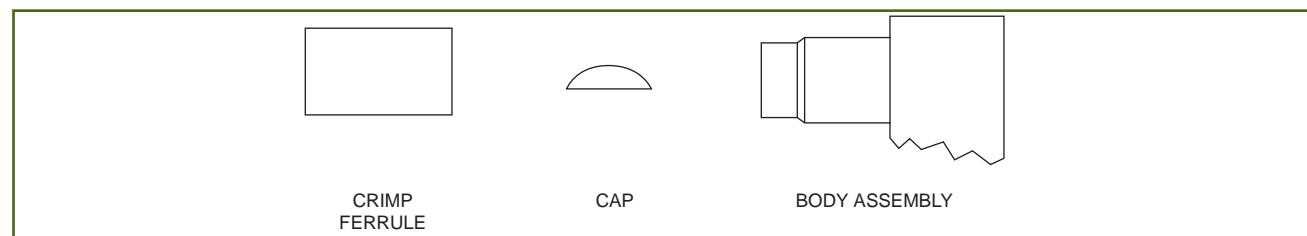

1. Slide ferrule on to cable.
2. Trim cable dimension shown next to the applicable connector drawing on page 15.
3. Tin center conductor (DO NOT OVER TIN).
4. Slide body over cable dielectric and under the braid until braid is flush against underside of body. Ensure center conductor is located in the forked end of the contact. NOTE: When using cables with inflexible jackets it is permissible to make two 3.17 (.125) longitudinal slits in the outer jacket.

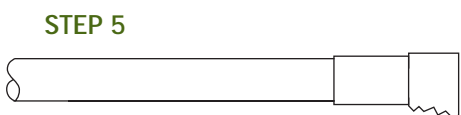

5. Slide ferrule flush against the body and crimp in position using Cannon's Crimp Tool and Suitable Die Set (see table on page 58).

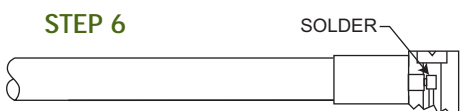

6. Using a small soldering iron solder center conductor to contact. NOTE: The center conductor should not protrude beyond the contact or touch the body. Solder should not protrude beyond the slotted section of the contact.

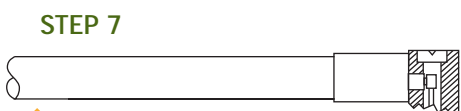

7. Locate the cap in rear of body and press flush to outer body to ensure it is locked in position.

**CSMA 3 - SMA Straight Connectors, Direct Solder  
(Cable Conductor used as Center Contact) Type for Semi-Rigid Cable**

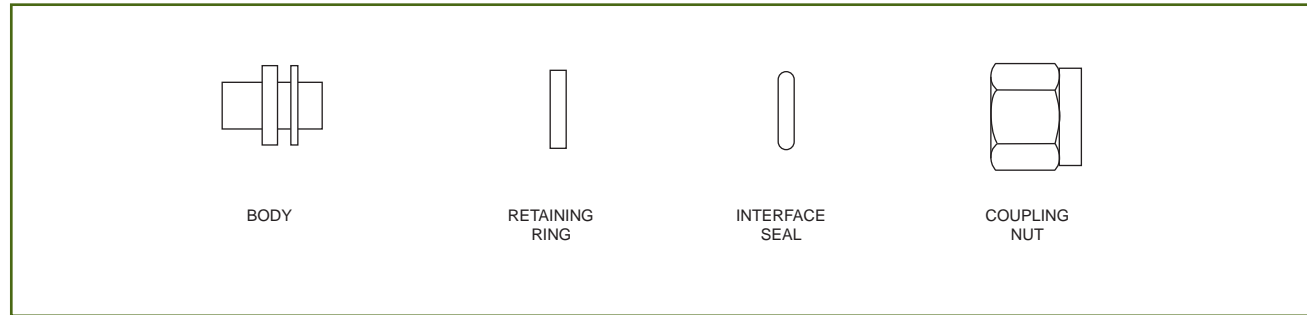

**STEP 1**

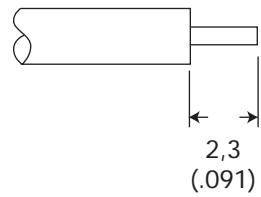

1. Remove the cable outer conductor and dielectric to the dimension shown taking care not to nick the center conductor using cable cutting tool. Deburr outer conductor at point of cut.

**STEP 2**

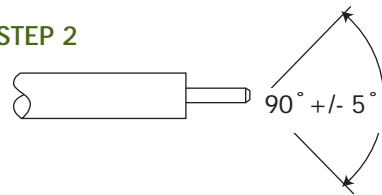

2. Point the end of the center conductor using a miniature file or suitable tool.

**STEP 3**

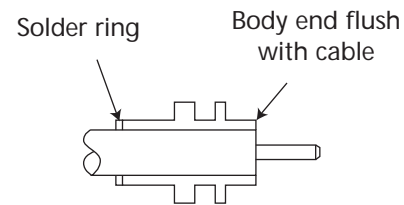

3. Clean housing area of outer conductor with abrasive paper and clean in a suitable agent. Ensure body is correct way round. Solder body ensuring end of cable to be flush with end of connector body as shown.
4. Fit the interface seal.
5. Install the spring retaining ring, compress with circlip pliers and fit the coupling nut.

**CSMA 4 - SMA Straight Connectors,  
Direct Solder (Separate Center Contact) Type for Semi-Rigid Cable**

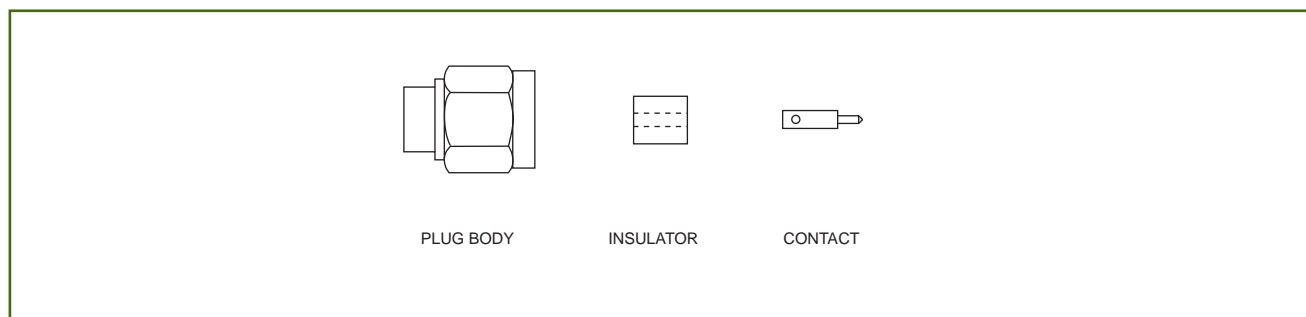

**STEP 1**

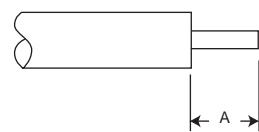

1. Cut cable end square. Remove the cable outer conductor and dielectric to the dimension shown taking care not to nick the center conductor. Deburr outer conductor at point of cut.

| A                             | B           |
|-------------------------------|-------------|
| 3.18 +/- 0.25 (.125 +/- .010) | 0.38 (.015) |

**STEP 3**

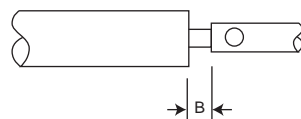

2. Tin center conductor. (DO NOT OVER TIN)
3. Solder contact to center conductor ensuring that the dimension shown is maintained. Remove any excess solder.

**STEP 5**

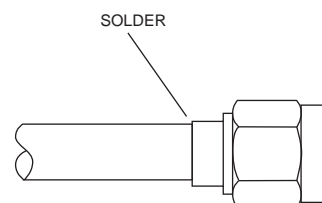

4. Clean housing area of outer conductor with abrasive paper and clean in a suitable agent.
5. Clamp the connector assembly in a suitable fixture. Ensure that the contact is in the correct interface position. Place soldering ring around cable adjacent to connector body and heat the connector body using an appropriate heat source. Apply sufficient heat for solder to flow but using minimum heat cycle.

**STEP 6**

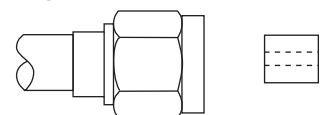

6. Using dielectric insertion Tool T2508, press insulator into body. Assembly is now ready for use.



**CSMA 5 - SMA Right Angle Connectors,  
Direct Solder Type for Semi-Rigid Cable**

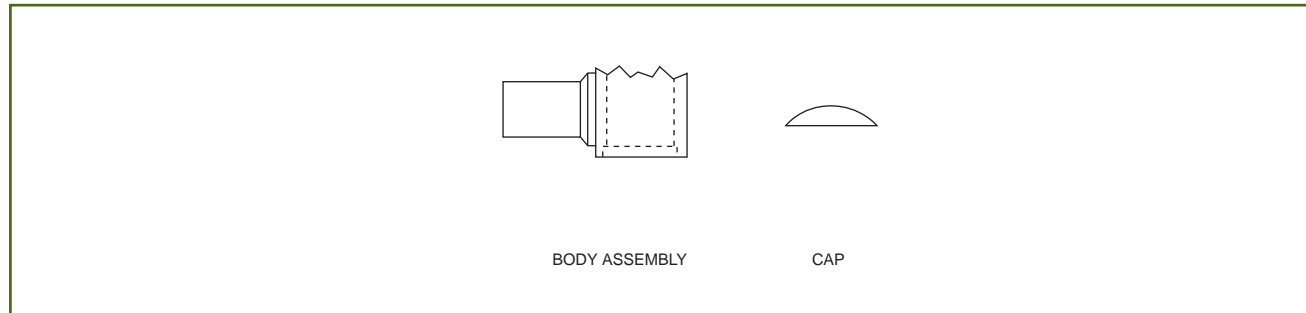

**STEP 1**

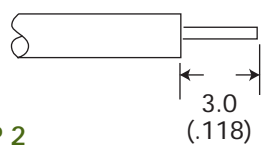

1. Remove cable outer conductor and dielectric to the dimension shown, being careful not to fracture the center conductor. Tin center conductor (DO NOT OVER TIN).

**STEP 2**

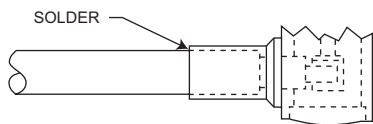

2. Slide cable into body and solder into place.

**STEP 3**

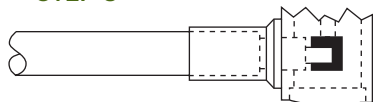

3. Solder center conductor to contact (do not over solder), then locate the cap in rear of body and press flush to outer body to ensure it is locked in position.

Centre Contact Crimp Tool

|             |
|-------------|
| Part Number |
| 995-001-584 |

Positioner for use with T4897

|                           |
|---------------------------|
| Part Number               |
| T4898 for male contacts   |
| T4899 for female contacts |

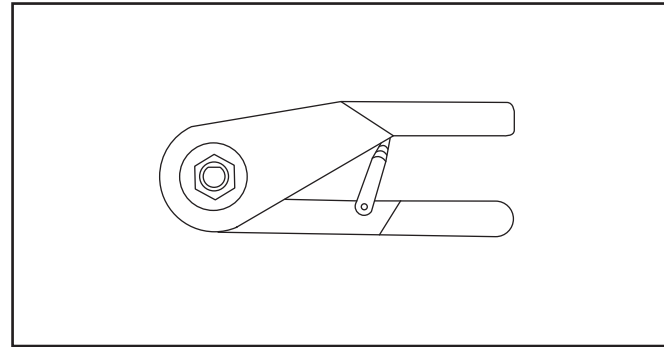

Ferrule Crimp Tool

|             |
|-------------|
| Part Number |
| T1025 / -   |

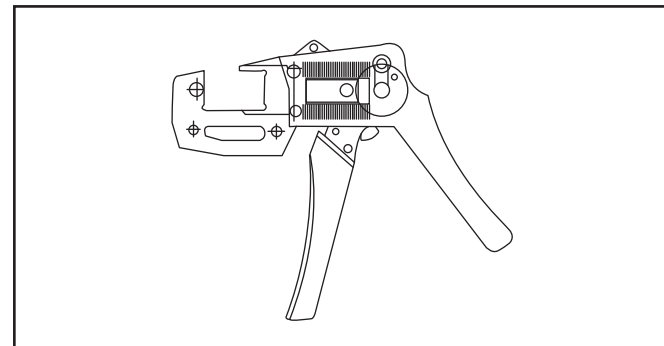

Die Set for use with T1025 / -

| Part Number | Cable Numbers | Die Size    | Part Number |
|-------------|---------------|-------------|-------------|
| RG141/U     | 9141          | 5.42 (.213) | K29265      |
| RG142/U     | 9142          | 5.42 (.213) | K29265      |
| RG316       | 9188          | 3.25 (.128) | K29263 *    |
| RD316       | 9875          | 3.84 (.151) | T1025/9     |

\* Three way die set (illustrated)

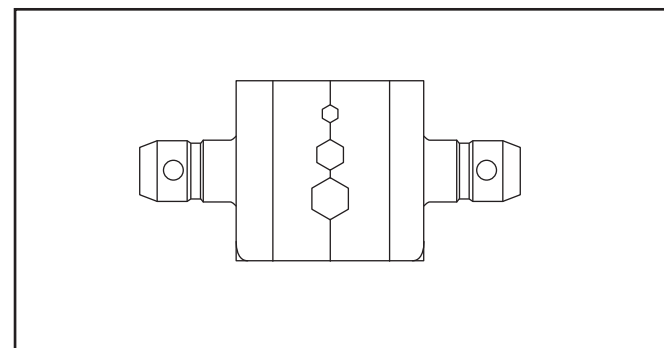

Torque Wrench (for SMA coupling nut - mating)

| Jaw Size    | Torque Nm (in oz)     | Part Number |
|-------------|-----------------------|-------------|
| 7.92 (.312) | 0.99 - 1.06 (140-150) | T0854/12/E  |

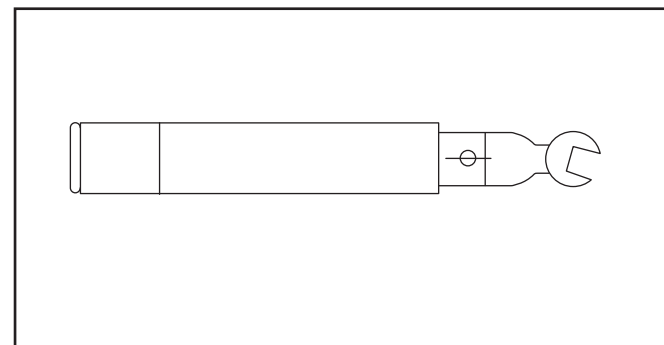

**TORQUE WRENCHES**

| Torque Wrench Application | Jaw Size     | Torque Nm (in. ozs.) | Torque Wrench Part Number |
|---------------------------|--------------|----------------------|---------------------------|
| SMA Coupling Nut          | 7,92 (.312)  | 0,99-1,06 (140-150)  | T0854/12/E                |
| SMA Assembly              | 7,92 (.312)  | 0,99-1,06 (140-150)  | T0854/12/E                |
| SMA Locknut               | 7,92 (.312)  | 1,50-1,54 (212-218)  | T0854/12/Z4               |
| SMB Coupling Nut          |              |                      | N/A                       |
| SMB Assembly              | 5,57 (.219)  | 0,64-0,71 (90-100)   | T0854/8/C                 |
| SMB Locknut               | 6,35 (.250)  | 0,71-0,78 (100-110)  | T0854/10/D                |
| SMC Coupling Nut          | 5,95 (.234)  | 0,42-0,49 (60-70)    | T0854/9/A                 |
| SMC Assembly (Crimp)      | 5,57 (.219)  | 0,64-0,71 (90-100)   | T0854/8/C                 |
| SMC Assembly (Clamp)      | 5,95 (.234)  | 0,64-0,71 (90-100)   | T0854/9/C                 |
| SMC Locknut               | 6,35 (.250)  | 0,71-0,78 (100-110)  | T0854/10/D                |
| SSMB Coupling Nut         |              |                      | N/A                       |
| SSMB Assembly             | 3,97 (.156)  | 0,13-0,14 (18-20)    | T0854/7/G                 |
| SSMB Locknut              | 4,75 (.187)  | 0,25-0,30 (35-50)    | contact customer service  |
| SSMC Coupling Nut         | 3,97 (.156)  | 0,18-0,21 (25-30)    | T0854/7/M                 |
| SSMC Assembly             | 3,97 (.156)  | 0,13-0,14 (18-20)    | T0854/7/G                 |
| SSMC Locknut              | 4,75 (.187)  | 0,25-0,30 (35-50)    | contact customer service  |
| BNC Adaptor Locknut       | 14,27 (.562) | 2,9-3,1 (411-439)    |                           |
| Type N Adaptor Coupling   | 17,45 (.687) | 1,2-1,6 (170-227)    |                           |
| Type N Adaptor Locknut    | 19,05 (.750) | 1,8-2,2 (255-312)    |                           |

Note: This is not the entire range of Torque Wrenches. Please contact customer service for details of other styles.

**CRIMP TOOLS AND DIE SETS**

| Description   | Old Part Number    | New Part Number      |                  |                |
|---|--------------------|----------------------|------------------|----------------|
| Crimp Tool without Die Set                          | 050-000-0000000    | T1025/-              |                  |                |
| Die Set for Cables RG178/U, 196U                    | 050-000-0290000 *  | K29263 *2,67 (.105)  |                  |                |
| Die Set for Cables RG174/U, 316U, 179U              | 050-000-0290000 *  | K29263 * 3,25 (.128) |                  | A/F Dimensions |
| Die Set for Cable RG142/U                           | 050-000-0291000 ** | K29265 5,41 (.213)   | * 3 way die set  | 2,67 (.105)    |
| Die Set for Cable RD316                             | 050-000-0292000    | T1025/9 3,84 (.151)  |                  | 3,25 (.128)    |
| Die Set for Cable RG196<br>(for SSMB / SSMC Series) | -                  | T1025/1 2,67 (.105)  | ** 2 way die set | 4,52 (.178)    |
| Die Set for Cable RG316<br>(for SSMB / SSMC Series) |                    | T1025/4 3,25 (.128)  |                  | 3,25 (.128)    |
|   |                    |                      |                  | 5,41 (.213)    |

Note: This is not the entire range of Crimp Tools. Please contact customer service for details of other styles.

Attenuation - Decrease in power due to resistance or mismatch in transmission line.

Back Mounted - When applied to a coaxial connector it is that connector mounted from the rear of a panel with the fixing nut on the outside.

Bandwidth - Distance between two frequencies over which a RF or microwave device is intended to work.

Between Series Adaptor - An adaptor used to connect two different generic types of connector.

BNC - Bayonet Nut Connector.

Braid - A weave of metal strands used as an electrical shield for an insulated conductor or group of conductors.

Bulkhead Mount - The type of connector fitted to a chassis using a single cut-out hole.

Cable Retention - The mechanism that joins the connector to the cable.

Cable Retention Force - The axial force which a connector / cable join can withstand.

Captive - A component such as a contact which is held firmly in position.

Characteristic Impedance - That impedance at which the transmission line is intended to work. A change from the characteristic impedance along its length will cause mismatch and loss of power.

Clamp - The holding of a cable by use of a screw thread action.

Closed Entry Contact - A female contact which is designed to prevent insertion of a contact larger than that specified.

Coaxial Cable - A transmission line where the one conductor is concentric inside another, often abbreviated to "coax".

Coaxial Termination - A resistive element used to end a coaxial line in its characteristic impedance.

Coaxial Terminator - A device for terminating coaxial cable to a PCB or bulkhead mount (a mechanical device and should not be confused with coaxial termination)

Conhex - Tradename covering SMB and SMC, both in 50 Ohm and 75 Ohm impedance (discontinued)

Connector Durability - The number of times a connector can be physically mated and still maintain its specified performance.

Contact Resistance - The measurement of the DC electrical resistance between a pair of mated contacts. Usually specified as being measured after a given number of mating cycles.

Corona - A discharge of electricity caused by the ionisation of the air around a conductor just prior to total breakdown or flashover.

Crimp - The action of distorting a metal tube to give intimate contact with a conductor; a good crimp should be gas tight and not be impacted by environmental change.

Crimp Dies - The tool inserts which determine the shape of the distortion to create a consistently good crimp.

Crimp Tool - The tool which holds crimp dies to apply the necessary force.

Cross Talk - The amount of signal which may be transferred from one signal carrying line to an adjacent line.

Cut Off Frequency - The frequency at which the loss exceeds a predetermined level.

Decibel (dB) - A unit of measurement of RF power loss.

Dielectric - The insulating medium which holds the center conductor concentric within the connector or cable.

Dielectric Constant - The electrical value of dielectric which determines the impedance in cables or connectors

with constant diameters.

Dielectric Withstanding Voltage - The maximum voltage that a dielectric material can withstand without failure.

Direct Solder - A common method of terminating connectors to semi-rigid cable by soldering the cable jacket to the connector.

Discontinuity - A dramatic change in characteristic impedance which gives rise to a reflected wave.

Dissipation - The unused or lost energy in a system e.g. heat.

Distortion - An unwanted change in a signal wave form.

Dummy Load - A device connected to the end of a transmission line to absorb transmitted power and prevent reflected energy.

Dust Cap - A mechanical device attached to the mating face of an unmated connector to prevent ingress of contaminants and provide protection against mechanical damage.

Electromagnetic Compatibility (EMC) - The ability of a device to operate within its intended environment without being effected by or generating electromagnetic interference (EMI).

Engagement and Separation Forces - The forces required to mate and unmate a pair of connectors. The forces are usually specified as a max & min for each action.

Environmentally Sealed - A connector that is provided with seals or other devices to prevent ingress of dust, moisture or other contaminants while mated which might impair performance.

Flexible Cable - A coaxial cable where the outer conductor is flexible (usually braided).

Gigahertz (GHz) - A measure of frequency representing 1 billion Hertz (cycles per second).

Impedance - See 'Characteristic Impedance'

In-Series Adaptor - An adaptor which enables the connection of two connectors of the same generic type.

Insertion Loss - The loss of power due to a particular component in a transmission line (e.g. cable).

Insulation Resistance - The electrical resistance between two conductors separated by an insulating medium.

Intermodulation - The mixing of two or more frequencies which are not intended to mix.

Interface - The two surfaces of a connector which come into intimate contact when the two halves are mated.

Inter-series Adaptor - See 'Between Series Adaptor'

Isolation - The measure of interaction between two or more transmission lines.

Jack - One half of a mating pair of connectors. The jack interface normally goes inside the plug interface.

Mean Power - The mean value of the rate at which energy is transmitted from one place to another.

Micro Strip - A transmission line consisting of a flat conductor on a dielectric above a single ground plane. (The ground plane is frequently a metalized face of the dielectric).

Microwave - Very short electromagnetic waves. Frequency range above 1 GHz.

MIL-C-39012 - The generic specification covering USA Military coaxial connectors.

MIL-C-17 - The generic MIL spec covering coaxial cables.

Mismatch - The condition in which the impedance of the source and load are not the same. This reduces power transfer and causes reflections.

Mounting Plan - The design of the PCB or panel cut-out used to mount the connector.  
N Connector - This was the first true microwave

connector capable of working to 18 GHz, initially designed for test applications.

Nanohex - Trade name covering SSMB & SSMC (discontinued)

Noise - An external electromagnetic signal which interferes with the desired signal.

Non-captive - A component such as a contact which does not have a retention feature.

Passivation - This is a surface treatment applied primarily to stainless steel. The process removes contaminating iron particles and produces a passive surface.

Peak Power - Is the maximum power which may be handled by a connector or cable.

Plug - One half of a mating pair of connectors. The plug interface normally goes outside the jack interface.

POSNS - Abbreviation for "positions".

PTFE - Abbreviation of polytetrafluorethylene. This is the most commonly used dielectric (insulator) used in professional coaxial connectors.

OPL - Qualified Parts List. Parts approved to MIL-C-390 12 specification.

Receptacle - A term used to describe a connector assembly usually bulkhead or PCB mounted.

Return Loss - A reason for loosing RF energy due to signals being reflected due to a mismatch in a transmission line.

RF Leakage - The RF power lost from a transmission line or device. Measured in dB.

RG - The traditional prefix for MIL spec coaxial cables.

Screw-on - The mating action of connectors which are joined using a screw thread (e.g. SMC)

Sealflex2™ - Cannon trade name for a flexible microwave cable assembly which has a performance similar to semi-rigid cable.

Semi-rigid Cable - A coaxial cable where the outer conductor is a solid metal tube.

Skin Effect - The tendency of alternating currents to flow near to the surface of a conductor; this increases resistance and becomes more marked the higher the frequency.

SMD - Sometimes used as an abbreviation for slide-on variants of SMB. This is a misnomer, the more common use is for Surface Mount Device.

Snap-on - A term used to describe the mating action of SMB and SSMB connectors.

Solderless SMA - An SMA connector that can be connected to semi-rigid cable by compressing the inner body rather than by soldering (sometimes referred to as semi-rigid 'crimp' connectors).

Stripline - A method of building a microwave circuit. The circuitry is sandwiched between 2 ground planes. Sometimes referred to as Tri-plate.

Teflon - DuPont tradename for PTFE.

Tensile Strength - The greatest force a device can withstand without tearing or pulling apart. This is frequently the method of determining the effectiveness of a crimp.

TNC - Thread Nut Connector same size as BNC; the only obvious difference is the coupling nut.

Tri-plate - See Stripline.

UG Symbol - Used to indicate a connector made to US government spec.

Voltage Standing Wave Ratio (VSWR) - A way of expressing the resultant loss of power as a result of signal reflections due to discontinuity.

| Part Number     | Page | Part Number     | Page | Part Number     | Page |
|-----------------|------|-----------------|------|-----------------|------|
| 050-007-0000220 | 24   | 051-427-3188220 | 29   | B51-024-0000220 | 21   |
| 050-024-0000220 | 24   | 051-443-0000220 | 29   | B51-024-3196220 | 21   |
| 050-027-0000220 | 24   | 051-445-0000220 | 30   | B51-024-9399220 | 21   |
| 050-043-0000220 | 25   | 051-452-0000220 | 30   | B51-051-9029220 | 23   |
| 050-045-0000220 | 25   | 055-607-2003890 | 9    | B51-053-0000220 | 23   |
| 050-047-0000220 | 25   | 055-607-9172890 | 9    | B51-053-9029220 | 23   |
| 050-074-6201310 | 35   | 055-607-9173890 | 9    | B51-328-3188220 | 21   |
| 050-424-3188220 | 31   | 055-611-3702890 | 9    | B51-328-3196220 | 21   |
| 050-424-3196220 | 31   | 055-611-3703890 | 9    | B51-328-9019AU0 | 21   |
| 050-428-3188220 | 31   | 055-939-9019AR6 | 33   | B51-328-9399220 | 21   |
| 050-428-3196220 | 31   | 055-939-9029AR6 | 33   | B51-351-0000220 | 23   |
| 050-443-0000220 | 31   | 055-939-9039AR6 | 34   | F50-E22-9141000 | 15   |
| 050-445-0000220 | 31   | 055-939-9049AR6 | 34   | F50-E22-9142000 | 15   |
| 050-451-0000220 | 32   | 055-939-9059AR6 | 34   | F50-E22-9188000 | 15   |
| 050-453-0000220 | 32   | 055-939-9069AR6 | 34   | F50-E22-9875000 | 15   |
| 050-622-9188890 | 8    | 065-9AA-0300000 | 39   | F50-E27-9188000 | 16   |
| 050-622-9875890 | 8    | 065-9AA-0500000 | 39   | F50-E27-9875000 | 16   |
| 050-627-9188890 | 8    | 065-9AA-0750000 | 39   | F50-E28-9141000 | 15   |
| 050-627-9875890 | 8    | 065-9AA-1000000 | 39   | F50-E28-9142000 | 15   |
| 050-628-9188890 | 8    | 065-9AA-1500000 | 39   | F50-E28-9188000 | 15   |
| 050-628-9875890 | 8    | 065-9AA-2000000 | 39   | F50-E28-9875000 | 15   |
| 050-645-4528890 | 10   | 065-9AA-2000000 | 39   | F50-E51-0000000 | 16   |
| 050-645-4540890 | 10   | 065-9AS-0500000 | 39   | F50-E53-0000000 | 16   |
| 050-645-4575890 | 10   | 065-9AS-1000000 | 39   | F55-E07-2003000 | 17   |
| 050-645-9009890 | 10   | 065-9AS-2000000 | 39   | F55-E07-9172000 | 17   |
| 050-651-0000310 | 11   | 065-9SS-0500000 | 39   | F55-E07-9173000 | 17   |
| 050-653-0000310 | 11   | 065-9SS-1000000 | 39   | F55-E11-3702000 | 17   |
| 050-673-0000890 | 12   | 065-9SS-2000000 | 39   | F55-E11-3703000 | 17   |
| 050-674-0000890 | 12   | 065-9SS-3000000 | 39   | K29263          | 59   |
| 050-674-6302310 | 35   | A50-624-9188890 | 8    | K29265          | 59   |
| 050-674-6324990 | 36   | A50-624-9875890 | 8    | T0854/10D       | 59   |
| 050-674-6700890 | 36   | A51-424-3196220 | 29   | T0854/12/E      | 59   |
| 050-675-0000890 | 12   | A51-427-3196220 | 29   | T0854/12/Z4     | 59   |
| 050-675-6705890 | 36   | A51-428-3188220 | 29   | T0854/7/G       | 59   |
| 050-675-6801890 | 36   | A51-428-3196220 | 29   | T0854/7/M       | 59   |
| 050-678-0000890 | 12   | A51-428-3875220 | 29   | T0854/8/C       | 59   |
| 051-027-0000220 | 21   | A51-451-0000220 | 30   | T0854/9/A       | 59   |
| 051-027-3196220 | 21   | A51-453-0000220 | 30   | T0854/9/C       | 59   |
| 051-027-9399220 | 21   | B50-051-0000220 | 26   | T1025/-         | 58   |
| 051-043-0000220 | 22   | B50-051-9019220 | 26   | T1025/1         | 58   |
| 051-045-0000220 | 22   | B50-053-0000220 | 26   | T1025/9         | 59   |
| 051-047-0000220 | 22   | B50-053-9019220 | 26   | T4897           | 58   |
| 051-075-0000220 | 21   | B50-328-3188220 | 24   | T4898           | 58   |
| 051-424-3188220 | 29   | B50-328-9399220 | 24   | T4899           | 58   |

THIS NOTE MUST BE READ IN CONJUNCTION WITH THE PRODUCT DATA SHEET/CATALOG. FAILURE TO OBSERVE THE ADVICE IN THIS INFORMATION SHEET AND THE OPERATING CONDITIONS SPECIFIED IN THE PRODUCT DATA SHEET/CATALOG COULD RESULT IN HAZARDOUS SITUATIONS.

## 1. MATERIAL CONTENT AND PHYSICAL FORM

Electrical connectors do not usually contain hazardous materials. They contain conducting and non-conducting materials and can be divided into two groups.

a) Printed circuit types and low cost audio types which employ all plastic insulators and casings.

b) Rugged, Fire Barrier and High Reliability types with metal casings and either natural rubber, synthetic rubber, plastic or glass insulating materials. Contact materials vary with type of connector and also application and are usually manufactured from either: Copper, copper alloys, nickel, alumel, chromel or steel. In special applications, other alloys may be specified.

## 2. FIRE CHARACTERISTICS AND ELECTRIC SHOCK HAZARD

There is no fire hazard when the connector is correctly wired and used within the specified parameters. Incorrect wiring or assembly of the connector or careless use of metal tools or conductive fluids, or transit damage to any of the component parts may cause electric shock or burns. Live circuits must not be broken by separating mated connectors as this may cause arcing, ionization and burning. Heat dissipation is greater at maximum resistance in a circuit. Hot spots may occur when resistance is raised locally by damage, e.g. cracked or deformed contacts, broken strands of wire. Local overheating may also result from the use of the incorrect application tools or from poor quality soldering or slack screw terminals. Overheating may occur if the ratings in the product Data Sheet/Catalog are exceeded and can cause breakdown of insulation and hence electric shock. If heating is allowed to continue it intensifies by further increasing the local resistance through loss of temper of spring contacts, formation of oxide film on contacts and wires and leakage currents through carbonization of insulation and tracking paths. Fire can then result in the presence of combustible materials and this may release noxious fumes. Overheating may not be visually

apparent. Burns may result from touching overheated components.

## 3. HANDLING

Care must be taken to avoid damage to any component parts of electrical connectors during installation and use. Although there are normally no sharp edges, care must be taken when handling certain components to avoid injury to fingers. Electrical connectors may be damaged in transit to the customers, and damage may result in creation of hazards. Products should therefore be examined prior to installation/use and rejected if found to be damaged.

## 4. DISPOSAL

Incineration of certain materials may release noxious or even toxic fumes.

## 5. APPLICATION

Connectors with exposed contacts should not be selected for use on the current supply side of an electrical circuit, because an electric shock could result from touching exposed contacts on an unmated connector. Voltages in excess of 30 V ac or 42.5 V dc are potentially hazardous and care should be taken to ensure that such voltages cannot be transmitted in any way to exposed metal parts of the connector body. The connector and wiring should be checked, before making live, to have no damage to metal parts or insulators, no solder blobs, loose strands, conducting lubricants, swarf, or any other undesired conducting particles. Circuit resistance and continuity check should be made to make certain that there are no high resistance joints or spurious conducting paths. Always use the correct application tools as specified in the Data Sheet/Catalog. Do not permit untrained personnel to wire, assemble or tamper with connectors. For operation voltage please see appropriate national regulations.

## IMPORTANT GENERAL INFORMATION

(i) Air and creepage paths/Operating voltage. The admissible operating voltages depend on the individual applications and the valid national and other applicable safety regulations.

For this reason the air and creepage path data are only reference values. Observe reduction of air and creepage paths due to PC board and/or harnessing.

(ii) Temperature

All information given are temperature limits. The operation temperature depends on the individual application.

(iii) Other important information

Cannon continuously endeavors to improve their products. Therefore, Cannon products may deviate from the description, technical data and shape as shown in this catalog and data sheets.

“Engineered for life” is a registered trademark of ITT Corporation © 2007. All other trademarks or registered trademarks are property of their respective owners. All data subject to change without notice.

## Product Warranty

ITT Electronic Components, a Division of ITT Corporation manufactures the highest quality products available in the marketplace; however these products are intended to be used in accordance with the specifications in this publication. Any use or application that deviates from the stated operating specifications is not recommended and may be unsafe. No information and data contained in this publication shall be construed to create any liability on the part of Cannon. Any new issue of this publication shall automatically invalidate and supersede any and all previous issues. A limited warranty applies to Cannon products. Except for obligations assumed by Cannon under this warranty, Cannon shall not be liable for any loss, damage, cost of repairs, incidental or consequential damages of any kind, whether or not based on express or implied warranty, contract, negligence or strict liability arising in connection with the design, manufacture, sale, use or repair of the products. Product availability, prices and delivery dates are exclusively subject to our respective order confirmation form; the same applies to orders based on development samples delivered. This publication is not to be construed as an offer. It is intended merely as an invitation to make an offer. By this publication, Cannon does not assume responsibility or any liability for any patent infringements or other rights of third parties which may result from its use. Reprinting this publication is generally permitted, indicating the source. However, Cannon's prior consent must be obtained in all cases.

Dimensions shown in mm (inch)  
Specifications and dimensions subject to change

[www.ittcannon.com](http://www.ittcannon.com)

## Over 90 year history ...

ITT Electronic Components is an innovative and dynamic company with the in-depth experience of a 90 plus year industry leader. We are part of ITT Corporation, a multi-disciplined, multi-national company engaged in the design and manufacture of electronic components, defense products and fluid handling controls.

ITT operates globally and is active in many diverse markets including telecom, carrier networks, wireless, medical electronics, instrumentation, military, microwave components, information systems and radar. ITT is an approved manufacturer to ISO 9001 and ISO 14001.



## Broad range of Cannon connectors and cable assemblies

In addition to our 50 Ohm RF product line, we also offer a range of 75 Ohm connectors including Type 43 (SMZ), 1.0/2.3, 1.6/5.6 and BNC.

### Cannon CoSMID™ connectors

CoSMID™ (Coax Surface Mount MID) 75 ohm connectors use molded interconnect device technology – a process which allows the selective metallization of 3D plastic shapes. Two, three or four coaxial connector lines can be integrated into a single surface mountable module. The modular design means that designers can incorporate more coax lines on a card edge than ever before.



### QT - Quick Termination Connectors

Quick Termination connectors have the special QT contact pre-assembled into the main connector assembly, which eliminates the process of crimping or soldering onto the center conductor of a cable. The center conductor is terminated to the inner contact within the connector assembly, by activating the QT (patented) mechanism using the simple plastic tool provided. The assembly is completed in 4 simple steps.

1. Strip cable using standard tooling.
2. Assemble connector on to cable.
3. Press insulator into connector body.
4. Crimp the ferrule using standard hex crimp tool to complete the termination.

The QT principle may be applied to 50 Ohm products also. Contact our Customer Service group for more information.

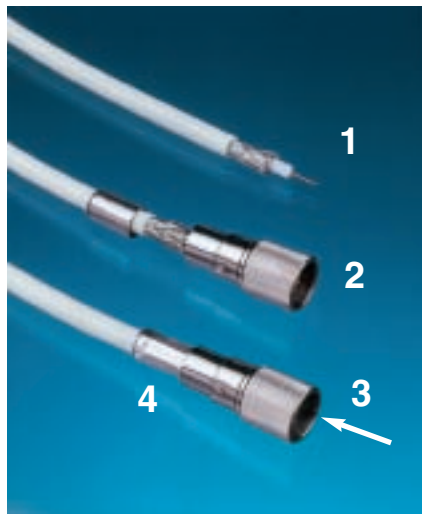

CoSMID is a trademark of ITT Corporation.  
CANNON, ENGINEERED FOR LIFE, the ITT "Engineered Blocks" symbol and the composite ITT logo are registered trademarks of ITT Corporation © 2007



ITT's Electronic Components business ([www.ittcannon.com](http://www.ittcannon.com)) is an international supplier of connectors, interconnects, cable assemblies, I/O card kits and smart card systems. As a worldwide leader in connector technology for nearly a century, ITT offers one of the industry's broadest product offerings, manufacturing capability worldwide, fast time to market, high volume/high yield capacity, robust design and Value-Based Product Development and an extensive sales and customer support network.



### Circular/Filter/Hermetic Connectors

As a world leader in circular, filter and hermetic connectors, ITT can leverage its design and manufacturing expertise to fit virtually any application. Our expertise includes fast positive mating for a wide range of military applications, as well as numerous sizes and contact configuration for various harsh environments. ITT can also meet numerous specs, including NATO and MIL standards.

[www.ittcannon.com/circulars](http://www.ittcannon.com/circulars) • [www.ittcannon.com/filter](http://www.ittcannon.com/filter) • [www.ittcannon.com/hermetics](http://www.ittcannon.com/hermetics)



### D-Subminiature Connectors

Cannon invented D-sub connectors in 1952. Our family of D-Subs now includes combinations of signal, power and RF, as well as severe service sealed connectors. Cannon D-Subs are available with an extensive line of backshells and accessories and are one of the most economical shielded connector solutions available. Qualified to the MIL-DTL-24308 specification.

[www.ittcannon.com/dsubs](http://www.ittcannon.com/dsubs)



### Fiber Optic Connectors

Cannon fiber optic solutions provide an excellent performance/cost value. Performance can be tailored to the end system, and our use of superior materials and bonding agents provides highly effective solutions. Our wide variety of products includes fiber optic hybrid contacts, multi-channel, rack and panel, and hi-rel assemblies, including MIL and ARINC standard solutions.

[www.ittcannon.com/fiberoptics](http://www.ittcannon.com/fiberoptics)



### Microminiature Connectors

Cannon microminiature connectors offer high performance and reliability with exceptional versatility. Available in rectangular, circular and strip configurations for countless applications, many of our connectors meet or exceed applicable requirements of the MIL-DTL-83513 specification.

[www.ittcannon.com/micro](http://www.ittcannon.com/micro)



### RF Connectors

Whether you need 50 Ohm or 75 Ohm RF connectors or 26 GHz high performance RF cable assemblies, or connector types including coax, BNC, SMA, SSMB or SBM, ITT has the solution. A leading supplier to numerous communications manufacturers for military and commercial OEMs, ITT offers unmatched expertise in RF connectors.

[www.ittcannon.com/rf](http://www.ittcannon.com/rf)





**ITT**

**Customer Support Locations**

*ASIA*

Tuopandun Industrial Area, Jinda Cheng,  
Xiner Village, Shajing Town,  
Baoan District, Shenzhen City,  
Guangdong, China 518125  
Tel: +86 755 2726 7238  
Fax: +86 755 2726 7515

*GERMANY*

Cannonstrasse 1  
Weinstadt, 71364  
Tel: +49.7151.699.0  
Fax: +49.7151.699.217

*ITALY*

Corso Europa 41/43  
Lainate (MI),  
Italy 20020  
Tel: +39.02938721  
Fax: +39.0293872300

*UK*

Jays Close, Viabes Estate  
Basingstoke, Hants, RG22 4BA  
Tel: +44.1256.311200  
Fax: +44.1256.323356

*USA*

100 New Wood Road  
Watertown, CT 06796  
Tel: 860.945.0206  
Toll Free: 800.683.7666  
Fax: 860.645.0303

[www.ittcannon.com](http://www.ittcannon.com)



**Electronic Components**

**Cannon 50 Ohm  
RF Connectors**

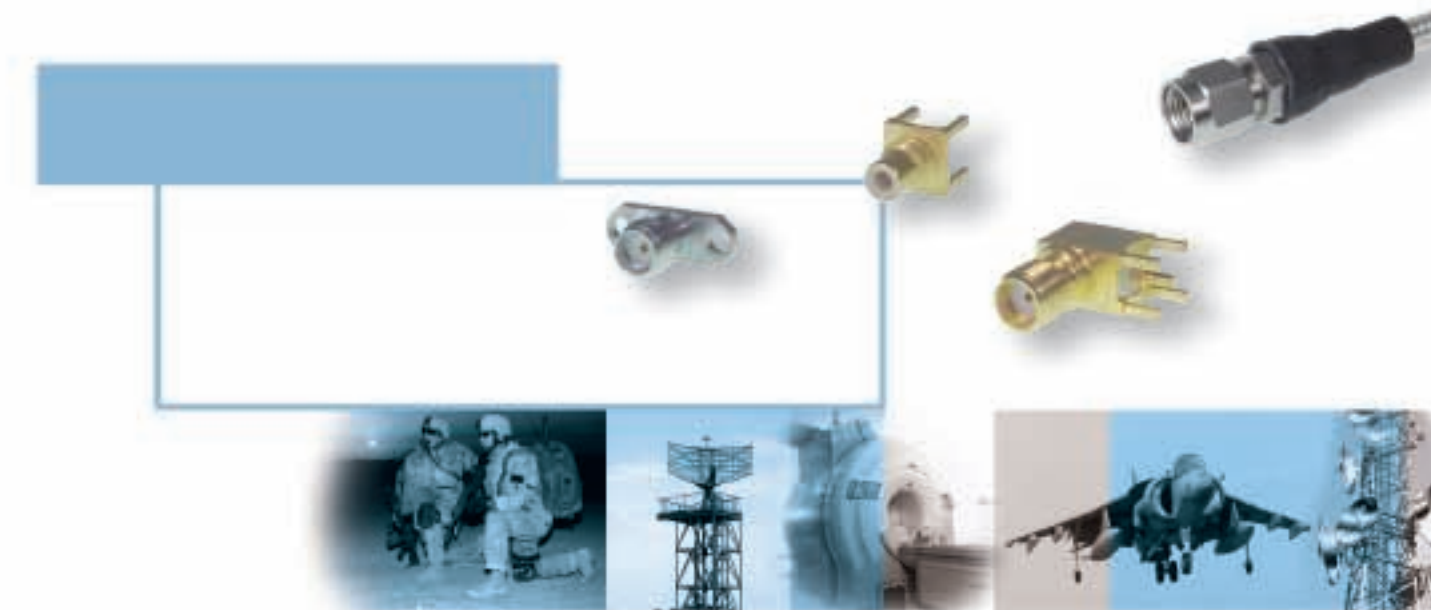

*Engineered for life*

©2007 ITT Corporation. "Engineered for life" and "Cannon" are registered trademarks of ITT Corporation. Specification and other data are based on information available at the time of printing, and are subject to change without notice.

50 RF Apr-07



## X-ON Electronics

Largest Supplier of Electrical and Electronic Components

*Click to view similar products for [ITT manufacturer](#):*

Other Similar products are found below :

[MS3106E22-14P](#) [CT6E18-11SCA206](#) [MS3101E2214PW](#) [CB1-18-1SSA34](#) [MDM-37PCBR-F222](#) [MS3101E2222SX](#) [KPSE06F20-41SA206F0](#) [CA3102E16-11SWB109](#) [DDM50SA190](#) [CA3101E10SL-4PBA176F42](#) [MS3101E181SW](#) [CB2-14S-6SCA232](#) [CA3101E10SL-4SF80DN](#) [M243082293Z](#) [CB2-14S-5SCA232](#) [KPSE00E10-6PW](#) [MS3102R16-10SY](#) [024251-0016-R](#) [024253-0025](#) [024265-0001](#) [024270-0015](#) [024271-0022](#) [024273-0043](#) [024288-0001](#) [M24308/24-21F](#) [CT1F22-7SS](#) [CT2-20-23SWS](#) [CT2-20-23SXS](#) [CT6E24-10PS-A206](#) [CT6F24-9PCA206](#) [CT6F36-10PCA152](#) [CT6F9767-14-4-14S-5PC](#) [CT6M20-23SXS](#) [CT6M20-23SYS](#) [CT6M20-23SZS](#) [D38999/20WJ35BC](#) [D38999/20WJ35SC](#) [D38999/26JH21PB-LC](#) [MD1-21PS](#) [MDB1-9SH001](#) [MDM-15PH001B-A174](#) [MDM-15PH003B-A174](#) [MDM-21SCBR-A174](#) [MDM25PH003BF222](#) [MDM-31SBRP](#) [MDM-37PBRT](#) [MDM37SH004PA174](#) [MDM-37SH013P](#) [MDM-51SCBRPL56](#) [MDM96514-336](#)