

cannon

Nano Microminiature Connectors Catalog



ITT

Amazing things happen When great things connect

ITT Cannon is a leading global manufacturer of connector products serving international customers in the aerospace and defense, industrial and medical end markets.

Whether delivering critical specs to aircraft pilots, streaming data through communications satellites or enabling ultrasound equipment to give expectant parents a first look at their unborn child, ITT Cannon connects the world's most important information to the people who need it.

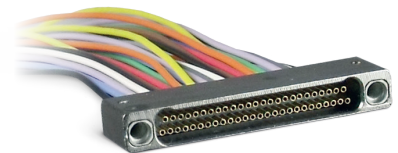
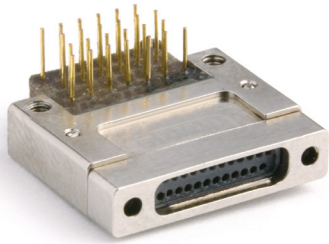

More than a Century of Connections

Since 1915, Cannon products have been used in a history of 'firsts'. From the first 'talking' movie to the first man on the moon, Cannon has set the standard for reliable, harsh environment interconnect solutions. Today we proudly continue our legacy of innovation with a goal to connect the world and inspire the successes of the next century - because amazing things happen when great things connect.

Visit ittcannon.com to learn more.

About ITT

ITT is a diversified leading manufacturer of highly engineered critical components and customized technology solutions for the energy, transportation and industrial markets. Building on its heritage of innovation, ITT partners with its customers to deliver enduring solutions to the key industries that underpin our modern way of life. Founded in 1920, ITT is headquartered in White Plains, N.Y., with employees in more than 35 countries and sales in a total of approximately 125 countries.

For more information visit itt.com

Dimensions shown in inches (mm)
Specifications and dimensions subject to change



Military & Defense



Industrial



Commercial Aerospace



Medical

ITT Cannon's connector portfolio

is one of the most extensive in the industry, offering customers a range of off-the-shelf and customized interconnect solutions for multiple markets and applications. Visit ittcannon.com to learn more.

Nano Microminiature Series Connectors (NDD & NDS)

Engineering Innovation

In the early 2000s, several of ITT Cannon's top tier customers approached our engineering and product management teams about their growing need for a high density, low profile connector that allowed more signal carrying capacity in a smaller design package than the Cannon Microminiature connectors they were currently using. These smaller, robust connectors also needed to perform in high shock, high vibration and high temperature environments and incorporate ITT's standard twist pin contact system as part of its design.

So our engineers and designers immediately went to work, gathering information from multiple OEMs and correlating input with market trend data for small form factor interconnects. Based on these insights, as well as our extensive expertise in manufacturing Microminiature interconnect technologies, we designed, engineered and introduced the dual row Nano Microminiature Connector Series.

Nano Connectors for the Modern World

Today, our innovative family of harsh environment Nano Microminiature Connectors continues to deliver higher density signals in a smaller profile design package across multiple markets and applications. They are available in multiple configurations including 9 to 51 contact positions and PCB versions. This high density interconnect package also provides a robust shock and vibration capable solution. Its unique knurled jackscrew assemblies allow for easier mating and de-mating, which is essential for small form factor connectors. Both our NDD and NDS Series can be rated up to 200°C based on Cannon's material selection and process technologies.



Key Markets & Applications



MILITARY AVIATION
Avionics



OIL & GAS INDUSTRY
Exploration & Extraction



DEFENSE
Missile Systems

Dimensions shown in inches (mm)
Specifications and dimensions subject to change

Product Design & Technical Information

High Performance in a Small Design Package

ITT Cannon's Nano Microminiature Series Connectors are small form factor high density interconnects designed and manufactured for high reliability and harsh environment applications. These interconnects are ideal when size and weight limitations require an ultra-low profile and robust interconnect design package. Using our innovative twist pin contact system on 0.025 contact spacing and 5 points of electrical contact, the Nano Microminiature offers an extremely rugged small form factor interconnect solution.

Twist Pin Contact System: A Cannon Innovation

At the heart of our Nano Series is our proven twist pin contact system, which features superior electrical and mechanical technology that outperforms traditional machined or stamped electrical contact systems. Highly reliable twist pin technology allows continuity in very dense areas and under severe shock and vibration, requiring low engagement and separation forces. Termination can consist of uninsulated pigtails or insulated wire all pre-harnessed at our factory to customer specifications. Used in our larger MDM Series Connectors for decades, twist pin contact technology was originally developed and introduced by Cannon engineers in the early 1960s, and we were the original interconnect company to license it.

Applications

- Commercial & Military Avionics
- Oil & Gas Exploration / Extraction
- Soldier-Worn Systems
- Industrial Control Systems
- Missile Defense Systems
- Medical Diagnostics Equipment

Key Product Features

- Micro Twist Pin Contact System
- 0.025 Contact Spacing
- 9 to 51 Contact Positions
- Knurled Jack Screw Assembly Hardware

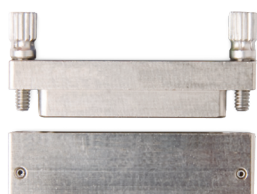

Standard hardware accessories featuring jackscrew assembly option accommodates increased functionality in user applications



Knurled Jack Screw Assembly Hardware improves ease of mating & de-mating, which is essential for small Nano Microminiature Connectors



High temperature LCP dielectric material providing wider range of operating capabilities for hostile environments



Proven twist pin contact construction with 5 points of electrical contact and high reliability crimp joints yields robust contact performance

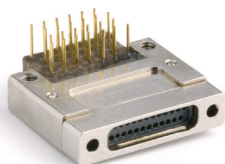

Thru hole PCB Mount with mating plug connector accommodates placement directly on printed circuit boards. SMT versions will be available on future releases.

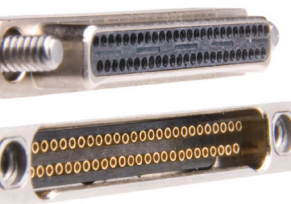
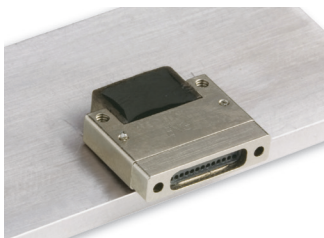

Multiple contacts layouts from 9 to 51 positions on 0.025 centers providing greater variability in data transmission requirements

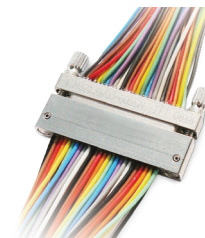

Cable Harnesses available in discrete insulated wires, ribbon cable and flex circuit terminations

Dimensions shown in inches (mm)
Specifications and dimensions subject to change

Table of contents

ITT Cannon Brand Overview	2-3
Introduction Nano Microminiature NDD & NDS Series Connectors	4
Product Design & Technical Overview	5
Nano Micro NDD & NDS Series Connectors, Performance Table.....	7
Nano Micro NDD & NDS Series Connectors, Stranded Wire.....	8
Nano Micro NDD & NDS Series Connectors, Solid Wire	9
Nano Micro NDD & NDS Series Connectors, Soldier Pot	10
Nano Micro NDD & NDS Series Connectors, Board Mount	11
Nano Micro NDD & NDS Series Connectors, Board Mount Plugs - Dimensions.....	12
Nano Micro NDD & NDS Series Connectors, Board Mount Plugs - Contact Arrangements.....	13
Nano Micro NDD & NDS Series Connectors, Board Mount Receptacles - Dimensions	14
Nano Micro NDD & NDS Series Connectors, Board Mount Receptacles - Contact Arrangement.....	15
Nano Micro Single Row Strip Connectors - .025" Contact Spacing - Performance Table	16
Nano Micro Single Row Strip Connectors - .025" Contact Spacing - Dimensions	17
Nano Micro NANO D Metal Shell - .025" Contact Spacing - Performance Table.....	18
Nano Micro NANO D Metal Shell - .025" Contact Spacing - Dimensions	19
Nano Micro Center Jackscrew - .030" Contact Spacing - Performance Table.....	20-21
Nano Micro Center Jackscrew - .030" Contact Spacing - Center Jackscrew /Rectangular	22
Nano Micro Center Jackscrew - .030" Contact Spacing - Contacts.....	23
Nano Micro Center Jackscrew - .030" Contact Spacing - L-Code Chart	24
Nano Micro Center Jackscrew - .030" Contact Spacing - H-Code Chart	25
About ITT Cannon.....	26
Product Safety Information.....	27
More Cannon Connectors	28
Amazing Things Happen When Great Things Connect	29

Nano Microminiature NDD & NDS Series Connectors



Performance Table

Mechanical, Environmental and Electrical Specifications	
Dialectric Withstanding Voltage	250VAC RMS at Sea Level, 100 VAC RMS at 70,000 feet
Contact Rating	1 Amp Max.
Wire Accomodation	30 - 32 AWG
Insulation Resistance	5000 Mega ohms min. at 100 VDC
Contact Resistance	Max. 71 millivolts drop with 1 Amp test current in accordance with EIA-364-06
Engagement/Separation Force	<5 oz/contact
Operating Temperature	-55°C to +125°C (+200°C)
Humidity	Per EIA-364, procedure 31A
Vibration	20g's in accordance with EIA-364-28, condition IV
Mechanical Shock	100g's, in accordance with EIA-364-27M condition G
Durability	500 mating/unmating cycles
Salt Spray/Corrosion Resistance	48 hour salt spray, in accordance with EIA-364-26, condition B
Thermal Vacuum Outgassing	Total Mass Loss (TML) 1.0% Max. Volatile Condensable Material (VCM) 0.1% Max.

Materials and Finish	
Shells	Aluminium with Cadmium or Electroless Nickel finish
Insulators	Liquid Crystal Polymer (LCP)
Pin Bundle	Precious Metal per ASTM B541, and per ASTM B477
Pin Sleeve	Nickel Silver, CDA Alloy 752 or ASTM B206. Gold Plated, 50 Microinches
Socket Contacts	Nickel Silver, CDA Alloy 752 or ASTM B206. Gold Plated, 50 Microinches
Hardware	Passivated Stainless Steel (Type 303)

Specifications	
Number of Contacts	9, 15, 21, 25, 31, 37 & 51
Contact retention	Fixed via Epoxy
Contact pitch	0.025 (0.64 mm)

* MIL-STD-202, Method 307, condition A

Dimensions shown in inches (mm)
Specifications and dimensions subject to change

Nano Microminiature NDD & NDS Series Connectors

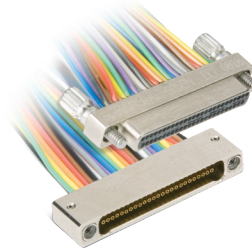

Stranded Wire

NDD - 25 P 0 P Y 18 K - A174

Series

- NDS - Dual Lobe Nano, Single Row
(Consult account rep for other mode codes)
- NDD - Dual Lobe Nano, Single Row
(Consult account rep for other mode codes)

Contact Arrangement

- 9, 15, 21, 25, 31, 37 & 51

Contact Type

- P - Pin
- S - Socket

Wire Gauge (AWG)

- 0 - #30 Gage (Standard)
- 2 - #32 Gage

Wire Type

- P - Teflon (PTFE) Wire Per NEMA-HP3 (MIL-W-16878/6) (Standard)
- E - Cross-Linked Tefzel (ETFE) Wire Per MIL-W-22759/33 (#30AWG Only)

Wire Color

- W - White
- Y - Yellow (Standard)
- T - Ten Color Repeat

Overall Wire Length (Inches)

- 1 Inch Minimum and Must be Rounded to the Nearest Whole Inch
- 5 - 5 Inches
- 18 - 18 Inches (Standard)
- 50 - 50 Inches
- 120 - 120 Inches

Hardware

- K - High Profile Jackscrew (Plugs Only) (Standard)
- T - Threaded Hole (Receptacles Only)
- N - No Hardware

Shell Finish/Mod Codes

- No Number - Yellow Chromate/Cadmium over Nickel (Not RoHS Compliant)
- A174 - Electroless Nickel (RoHS Compliant)
- (Consult Factory for all other Mod Codes)

Dimensions shown in inches (mm)
Specifications and dimensions subject to change

Nano Microminiature NDD & NDS Series Connectors

Solid Wire

NDD - 25 P 0 S G .250 K - A174

Series _____
 NDS - Dual Lobe Nano, Single Row
 (Consult account rep for other mode codes)
 NDD - Dual Lobe Nano, Dual Row

Contact Arrangement _____
 9, 15, 21, 25, 31, 37 & 51

Contact Type _____
 P - Pin
 S - Socket

Wire Gauge (AWG) _____
 0 - #30 Gage (Standard)
 2 - #32 Gage

Wire Type _____
 S - Solid Uninsulated

Wire Finish _____
 S - Solder-Dipped
 G - Gold (Standard)

Overall Wire Length (Inches) _____
 .010 Inch Minimum and Must be Rounded to the Nearest Thousandth of an Inch
 Examples:
 .050 - 0.050 inch
 .250 - 0.250 inch
 1.000 - 1.000 inch

Hardware _____
 K - High Profile Jackscrew (Plugs Only) Standard)
 T - Threaded Hole (Receptacles Only)
 N - No Hardware

Shell Finish/Mod Codes _____
 No Number/A101 - Yellow Chromate/Cadmium over Nickel (Not RoHS Compliant)
 A174 - Electroless Nickel (RoHS Compliant)
 (Consult Factory for all other Mod Codes)

Dimensions shown in inches (mm)
 Specifications and dimensions subject to change

Nano Microminiature NDD & NDS Series Connectors

Solder pot

NDD - 25 P S K - A174

Series

NDS - Dual Lobe Nano, Single Row
(Consult account rep for other mode codes)
NDD - Dual Lobe Nano, Dual Row

Contact Arrangement

9, 15, 21, 25, 31, 37 & 51

Contact Type

P - Pin
S - Socket

Termination Type

S - Solderpot Type

Hardware

K - High Profile Jackscrew (Plugs Only)
T - Threaded Hole (Receptacles Only)
N - No Hardware

Shell Finish/Mod Codes

No Number/A101 - Yellow Chromate/Cadmium over Nickel (Not RoHS Compliant)
A174 - Electroless Nickel (RoHS Compliant)
(Consult Factory for all other Mod Codes)

Dimensions shown in inches (mm)
Specifications and dimensions subject to change

Nano Microminiature NDD & NDS Series Connectors

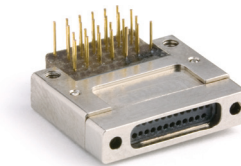

Board Mount

NDD - 25 P BR S - T T .109 A174

Series

NDS - Dual Lobe Nano, Single Row
(Consult account rep for other mode codes)
NDD - Dual Lobe Nano, Dual Row

Contact Arrangement

9, 15, 21, 25, 31, 37 & 51

Contact Type

P - Pin
S - Socket

Termination Type

BS - Straight PCB Thru- Hole Termination
BR - Right Angle PCB Thru- Hole Termination
BRS- Right Angle PCB Surface Termination

Hardware

T - Threaded Hole
N - No Hardware (Permitted with PCB Thru-Hole Only)

Wire Finish

S - Solder-Dipped
G - Gold (Standard)

Hardware

T - Threaded Hole (Receptacles Only)
N - No Hardware

Overall Wire Length (Inches)

.010 Inch Minimum and Must be Rounded to the Nearest Thousandth of an Inch

Examples:

.050 - 0.050 inch

.250 - 0.250 inch

1.000 - 1.000 inch

Shell Finish/Mod Codes

No Number/A101 - Yellow Chromate/Cadmium over Nickel (Not RoHS Compliant)
A174 - Electroless Nickel (RoHS Compliant)

Nano Microminiature NDD & NDS Series Connectors

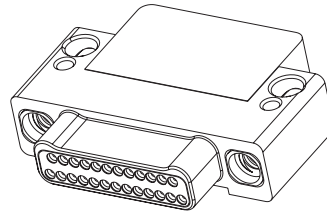

Board Mount Plugs | Dimensions

Size	A Ref.	B Ref.	C Ref.	D ±.005
9	.375	.270	.160	.170
15	.450	.345	.235	.245
21	.525	.420	.310	.320
25	.575	.470	.360	.370
31	.650	.545	.435	.445
37	.725	.620	.510	.520
51	.900	.795	.685	.695

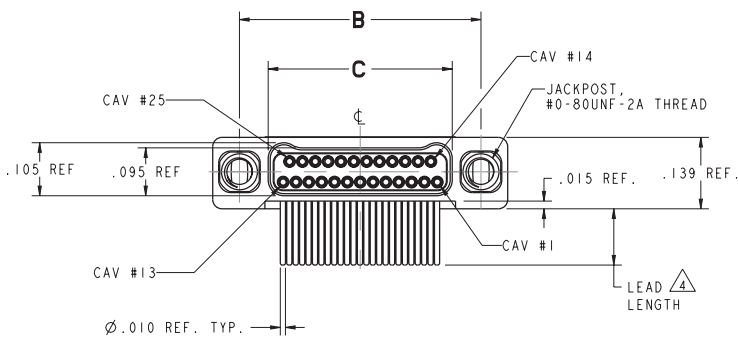

Front View

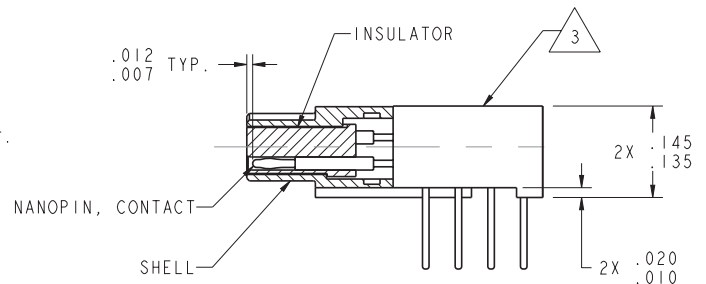

Side View

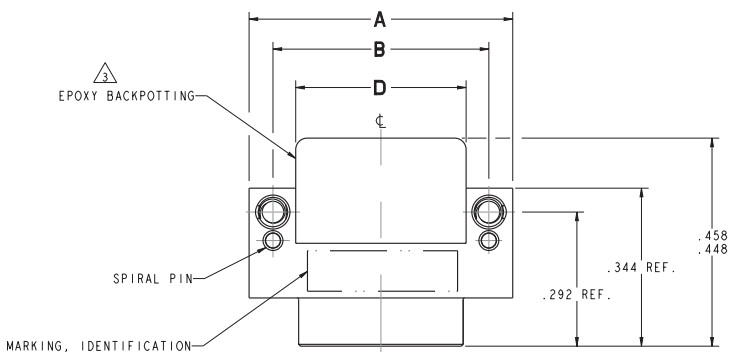

Top View

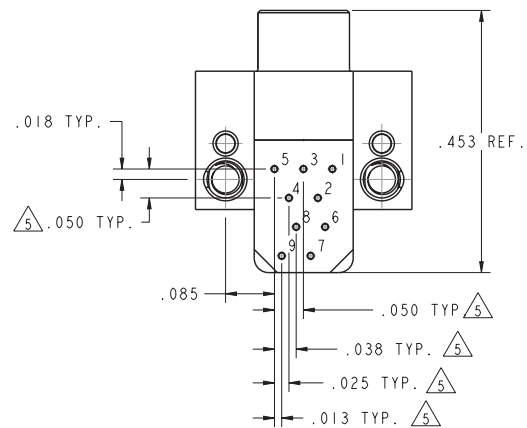

Size 9P

Dimensions shown in inches (mm)
Specifications and dimensions subject to change

Nano Microminiature NDD & NDS Series Connectors

Board Mount Plugs | Dimensions

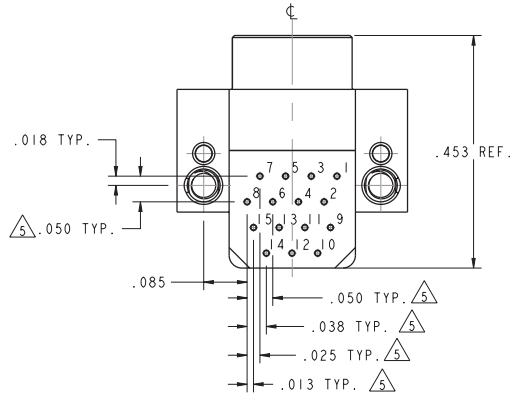

Size 15P

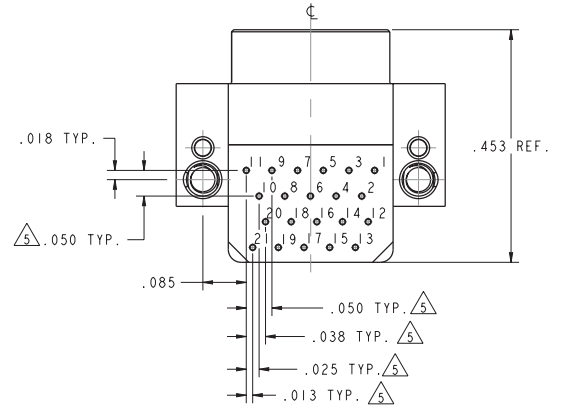

Size 21P

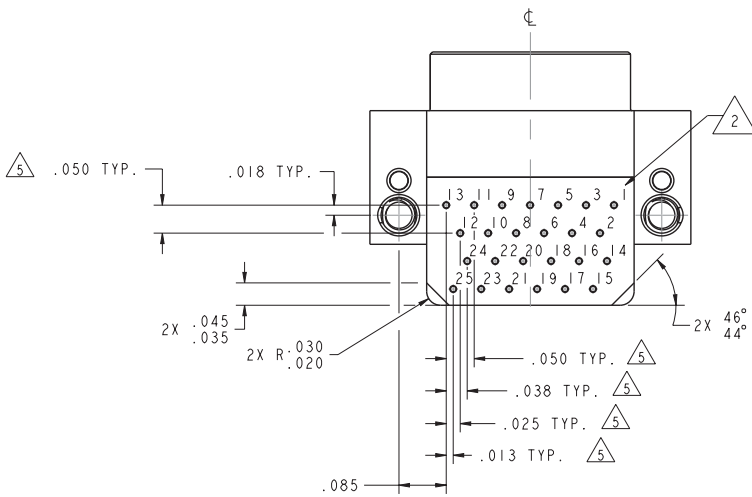

Size 25P

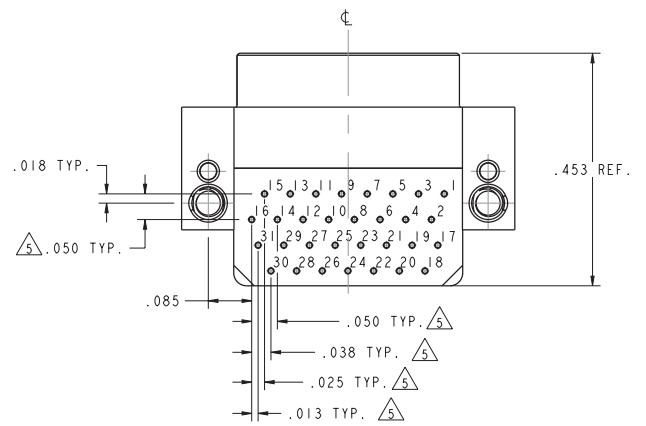

Size 31P

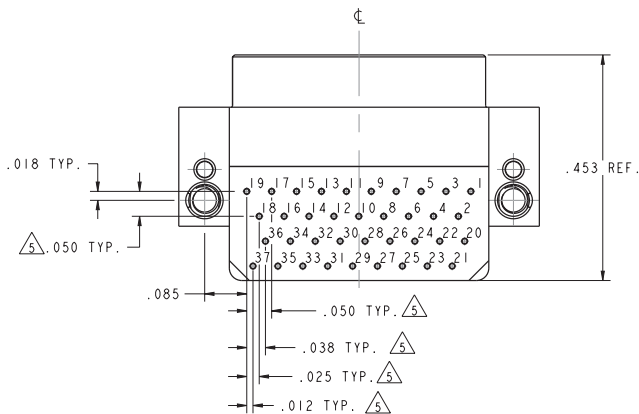

Size 37P

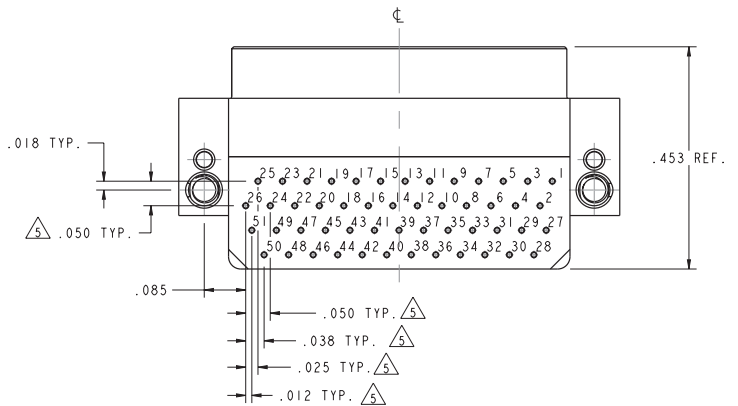

Size 51P

Dimensions shown in inches (mm)
Specifications and dimensions subject to change

Nano Microminiature NDD & NDS Series Connectors

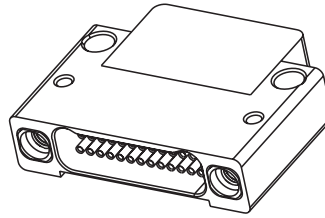

Board Mount Receptacles | Dimensions

Size	A Ref.	B Ref.	C Ref.	D ±.005
9	.375	.270	.163	.170
15	.450	.345	.238	.245
21	.525	.420	.313	.320
25	.575	.470	.363	.370
31	.650	.545	.438	.445
37	.725	.620	.513	.520
51	.900	.795	.688	.695

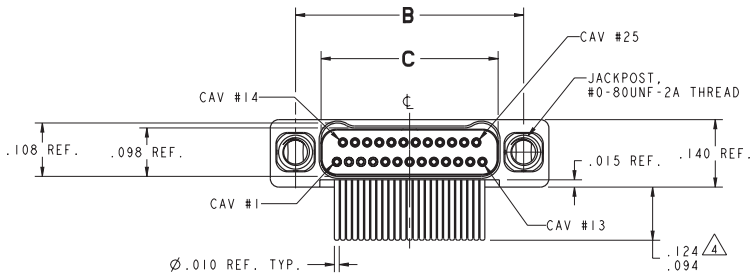

Front View

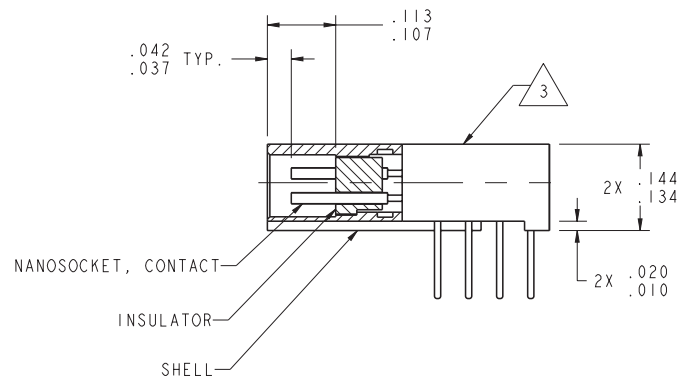

Side View

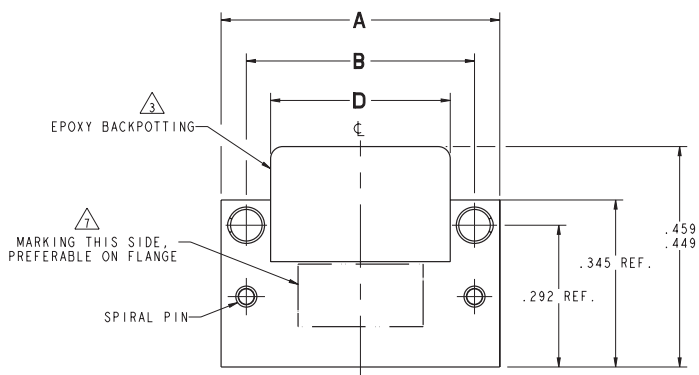

Top View

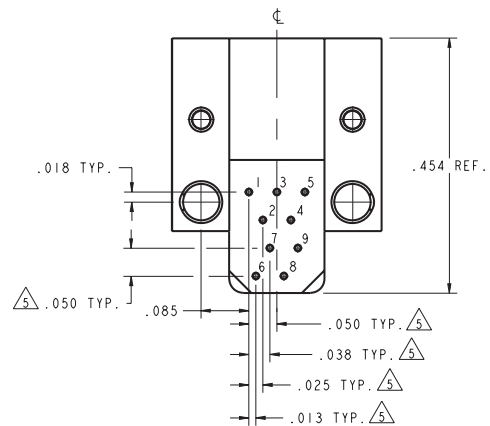

Size 9S

Dimensions shown in inches (mm)
Specifications and dimensions subject to change

Nano Microminiature NDD & NDS Series Connectors

Board Mount Receptacles | Contact Arrangements

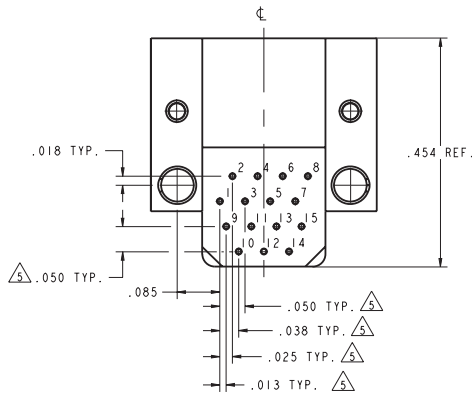

Size 15S

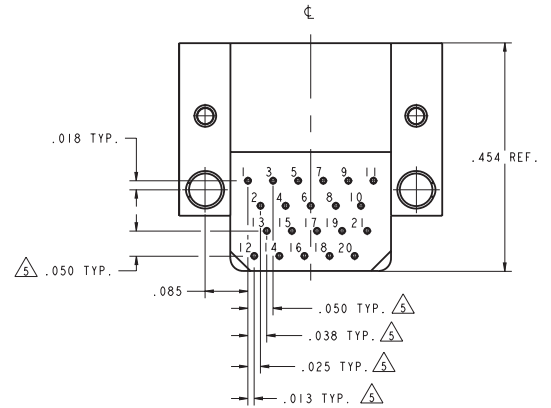

Size 21S

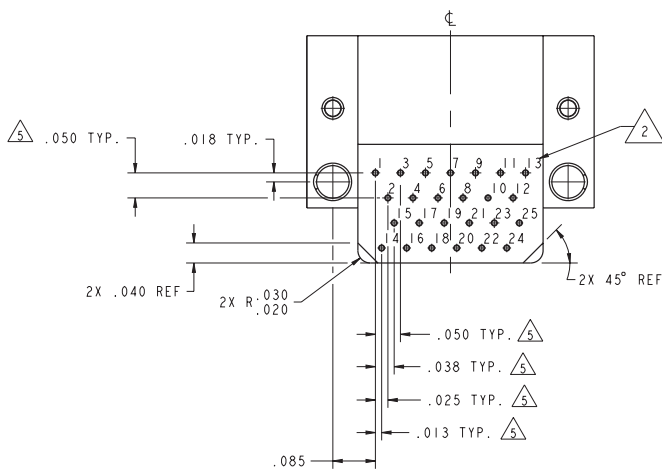

Size 25S

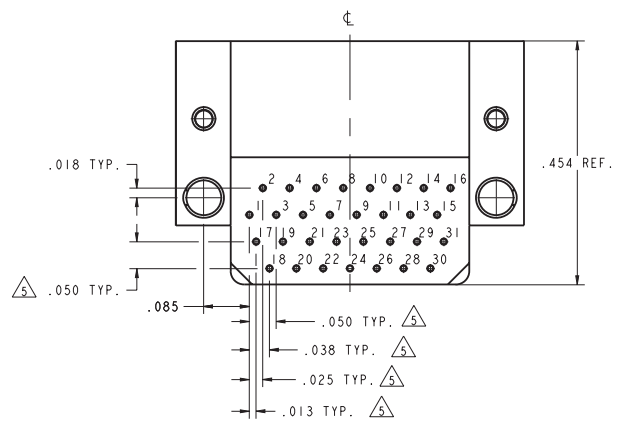

Size 31S

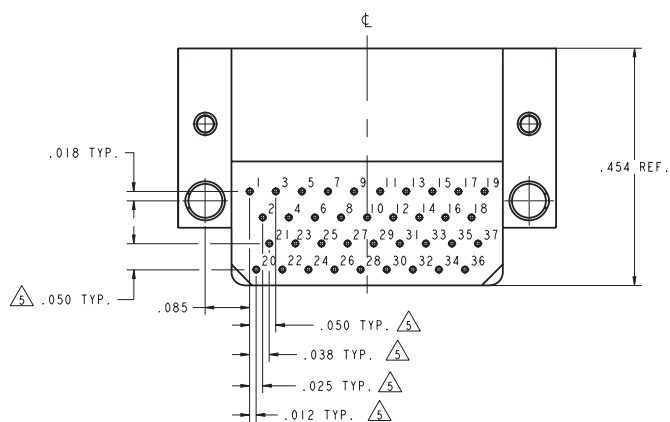

Size 37S

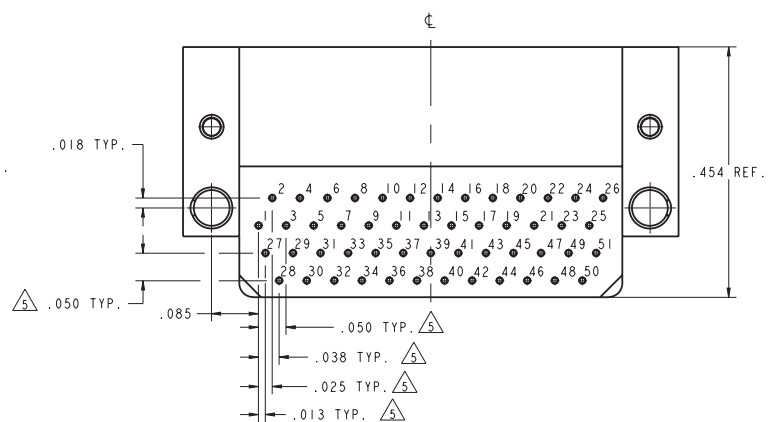

Size 51S

Dimensions shown in inches (mm)
Specifications and dimensions subject to change

Nano Microminiature Single Row Strip Connectors - .025" Contact Spacing

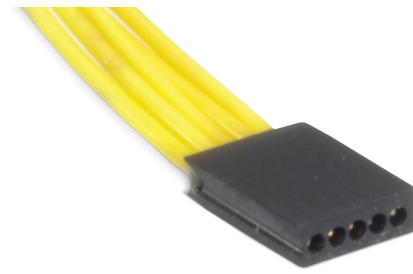

Performance Table

Mechanical, Environmental and Electrical Specifications	
Dielectric Withstanding Voltage	MIL-STD-202, Method 301, condition A
Contact Rating	1 Amp Max.
Wire Accomodation	32 AWG Stranded or 30 AWG Solid
Insulation Resistance	MIL-STD-202, Method 302, condition A
Contact Resistance	Max. 71 millivolts drop with 1 Amp test current in accordance with EIA-364-06
Engagement/Separation Force	<6 oz/contact
Operating Temperature	-65°C to +125°C
Moisture Resistance	MIL-STD-202, Method 106, omit 7B
Vibration	MIL-STD-202, Method 204, condition D
Mechanical Shock	MIL-STD-202, Method 213, condition B
Durability	500 mating/unmating cycles
Salt Spray/Corrosion Resistance	48 hour per MIL-STD-202, Method 101, condition B

Materials and Finish	
Insulators	Phenolic (Black)
Pin Bundle	Precious Metal per ASTM B477 and ASTM B451, or BeCu per CDA alloy 172 & 102
Pin Sleeve	Nickel Silver per ASTM B122, comp. B, or Cartridge Brass per CDA alloy 260
Socket Contacts	Nickel Silver per ASTM B122, comp. B

Specifications	
Number of Contacts	1 - 40
Contact retention	Fixed via Epoxy
Contact pitch	0.025 (0.64 mm)

* MIL-STD-202, Method 307, condition A
(Consult Factory for all other Mode Codes)

Dimensions shown in inches (mm)
Specifications and dimensions subject to change

Nano Microminiature Single Row Strip Connectors - .025" Contact Spacing

Dimensions

NTP

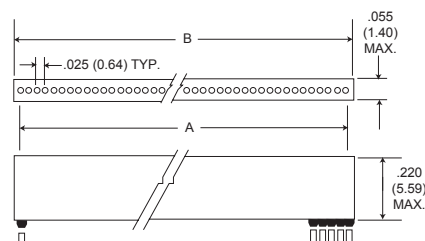

Plug - "H" and "L"
Termination Types

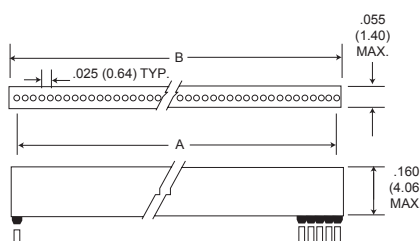

Plug - "T"
Termination Types

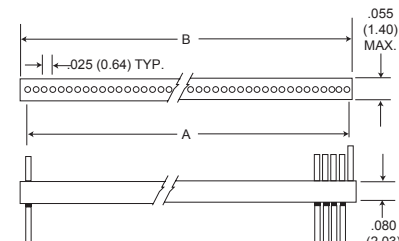

Receptacle - "H", "L" and "T"
Termination Types

Part Number by Insulator Size	A Ref.	B ±.010 (0.25)
NTP1-1*-.**	-	.050 (1.27)
NTP1-2*-.**	.025 (0.64)	.075 (1.91)
NTP1-3*-.**	.050 (1.27)	.100 (2.54)
NTP1-4*-.**	.075 (1.91)	.125 (3.18)
NTP1-5*-.**	.100 (2.54)	.150 (3.81)
NTP1-6*-.**	.125 (3.18)	.175 (4.45)
NTP1-7*-.**	.150 (3.81)	.200 (5.08)
NTP1-8*-.**	.175 (4.45)	.225 (5.72)
NTP1-9*-.**	.200 (5.08)	.250 (6.35)
NTP1-10*-.**	.225 (5.72)	.275 (6.99)

Part Number by Insulator Size	A Ref.	B ±.010 (0.25)
NTP1-11*-.**	.250 (6.35)	.300 (7.62)
NTP1-12*-.**	.275 (6.99)	.325 (8.26)
NTP1-13*-.**	.300 (7.62)	.350 (8.89)
NTP1-14*-.**	.325 (8.26)	.375 (9.53)
NTP1-15*-.**	.350 (8.89)	.400 (10.16)
NTP1-16*-.**	.375 (9.53)	.425 (10.80)
NTP1-17*-.**	.400 (10.16)	.450 (11.43)
NTP1-18*-.**	.425 (10.80)	.475 (12.07)
NTP1-19*-.**	.450 (11.43)	.500 (12.70)
NTP1-20*-.**	.475 (12.07)	.525 (13.34)

Part Number by Insulator Size	A Ref.	B ±.010 (0.25)
NTP1-21*-.**	.500 (12.70)	.550 (13.97)
NTP1-22*-.**	.525 (13.34)	.575 (14.61)
NTP1-23*-.**	.550 (13.97)	.600 (15.24)
NTP1-24*-.**	.575 (14.61)	.625 (15.88)
NTP1-25*-.**	.600 (15.24)	.650 (16.51)
NTP1-26*-.**	.625 (15.88)	.675 (17.15)
NTP1-27*-.**	.650 (16.51)	.700 (17.78)
NTP1-28*-.**	.675 (17.15)	.725 (18.42)
NTP1-29*-.**	.700 (17.78)	.750 (19.05)
NTP1-30*-.**	.725 (18.42)	.775 (19.69)

Part Number by Insulator Size	A Ref.	B ±.010 (0.25)
NTP1-31*-.**	.750 (19.05)	.800 (20.32)
NTP1-32*-.**	.775 (19.69)	.825 (20.96)
NTP1-33*-.**	.800 (20.32)	.850 (21.59)
NTP1-34*-.**	.825 (20.96)	.875 (22.23)
NTP1-35*-.**	.850 (21.59)	.900 (22.86)
NTP1-36*-.**	.875 (22.23)	.925 (23.50)
NTP1-37*-.**	.900 (22.86)	.950 (24.13)
NTP1-38*-.**	.925 (23.50)	.975 (24.77)
NTP1-39*-.**	.950 (24.13)	1.000 (25.40)
NTP1-40*-.**	.975 (24.77)	1.025 (26.04)

For further information, refer to ARINC 600 specification or consult your account representative.
*This dimension indicates distance from centerline of retaining screw to the centerline of first contact cavity.

Dimensions shown in inches (mm)
Specifications and dimensions subject to change

Nano Microminiature NANO D Metal Shell - .025" Contact Spacing

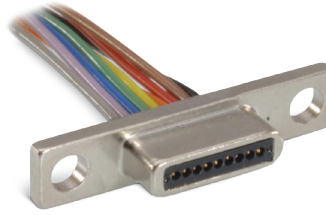

Performance Table

Mechanical, Environmental and Electrical Specifications	
Dielectric Withstanding Voltage	MIL-STD-202, Method 301, condition A
Contact Rating	1 Amp Max.
Wire Accomodation	32 AWG Stranded or 30 AWG Solid
Insulation Resistance	MIL-STD-202, Method 302, condition A
Contact Resistance	Max. 71 millivolts drop with 1 Amp test current in accordance with EIA-364-06
Engagement/Separation Force	<6 oz/contact
Operating Temperature	-65°C to +125°C
Moisture Resistance	MIL-STD-202, Method 106, omit 7B
Vibration	MIL-STD-202, Method 204, condition D
Mechanical Shock	MIL-STD-202, Method 213, condition B
Durability	500 mating/unmating cycles
Salt Spray/Corrosion Resistance	48 hour per MIL-STD-202, Method 101, condition B

Materials and Finish	
Shell	Aluminum Alloy 2024 T351 per QQ-A-250 or 6061-T6 per QQ-A-200, Electroless Nickel finish
Insulators	Polyester
Pin Bundle	Precious Metal per ASTM B477 and ASTM B451, or BeCu per CDA alloy 172 & 102
Pin Sleeve	Nickel Silver per ASTM B122, comp. B, or Cartridge Brass per CDA alloy 260
Socket Contacts	Nickel Silver per ASTM B122, comp. B

Specifications	
Number of Contacts	9, 15, 21, 25, 31 & 37
Contact retention	Fixed via Epoxy
Contact pitch	0.025 (0.64 mm)

* MIL-STD-202, Method 307, condition A

*This dimension indicates distance from centerline of retaining screw to the centerline of first contact cavity.
For further information, refer to ARINC 600 specification or consult factory.

Dimensions shown in inches (mm)
Specifications and dimensions subject to change

Nano Microminiature NANO D Metal Shell - .025" Contact Spacing

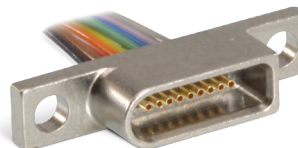

Dimensions

NDM

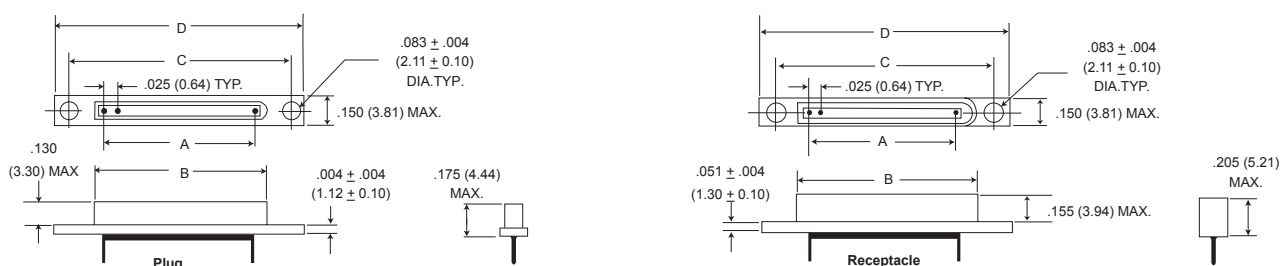

Part Number By Shell Size	A Ref.	Plug B Ref.	Receptacle B Ref.	C ± .005 (0.13)	D Max.
NDM-9P*/S*	.200 (5.08)	.317 (8.05)	.380 (9.65)	.565 (14.35)	.725 (18.42)
NDM-15P*/S*	.350 (8.89)	.467 (11.86)	.530 (13.46)	.715 (18.16)	.875 (22.23)
NDM-21P*/S*	.500 (12.7)	.617 (15.67)	.680 (17.27)	.865 (21.97)	1.025 (26.04)
NDM-25P*/S8	.600 (15.24)	.717 (18.21)	.780 (19.81)	.965 (24.51)	1.125 (28.58)
NDM-31P*/S*	.750 (19.05)	.867 (22.02)	.930 (23.62)	1.115 (28.32)	1.275 (32.39)
NDM-37P*/S*	.900 (22.86)	1.017 (25.83)	1.080 (27.43)	1.265 (32.13)	1.425 (36.20)

Panel Mount Dimensions

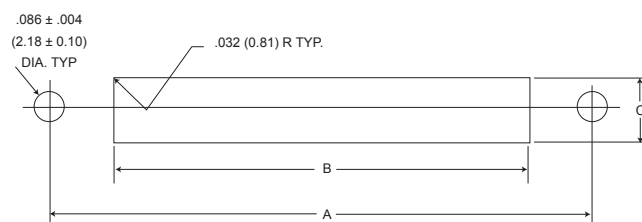

Size	A ± .005 (0.13)	B + .005 (0.13) - .000 (0.00)	C + .005 (0.13) - .000 (0.00)
9	.565 (14.35)	.261 (6.63)	.095 (2.41)
15	.715 (18.16)	.411 (10.44)	.095 (2.41)
21	.865 (21.97)	.561 (14.25)	.095 (2.41)
25	.965 (24.51)	.661 (16.79)	.095 (2.41)
31	1.115 (28.32)	.811 (20.60)	.095 (2.41)
37	1.265 (32.13)	.961 (24.41)	.095 (2.41)

Dimensions shown in inches (mm)
Specifications and dimensions subject to change

Nano Microminiature Center Jackscrew - .030" Contact Spacing



Performance Table

Mechanical, Environmental and Electrical Specifications	
Dielectric Withstanding Voltage	MIL-STD-202, Method 301, condition A
Contact Rating	1 Amp Max.
Wire Accomodation	32 AWG Stranded or 30 AWG Solid
Insulation Resistance	MIL-STD-202, Method 302, condition A
Contact Resistance	Max. 71 millivolts drop with 1 Amp test current in accordance with EIA-364-06
Engagement/Separation Force	<6 oz/contact
Operating Temperature	-65°C to +125°C
Moisture Resistance	MIL-STD-202, Method 106, omit 7B
Vibration	MIL-STD-202, Method 204, condition D
Mechanical Shock	MIL-STD-202, Method 213, condition B
Durability	500 mating/unmating cycles
Salt Spray/Corrosion Resistance	48 hour per MIL-STD-202, Method 101, condition B

Materials and Finish	
Insulators	Polyester
Pin Bundle	Precious Metal per ASTM B477 and ASTM B451, or BeCu per CDA alloy 172 & 102
Pin Sleeve	Nickel Silver per ASTM B122, comp. B, or Cartridge Brass per CDA alloy 260
Socket Contacts	Nickel Silver per ASTM B122, comp. B

Specifications	
Number of Contacts	9, 24 & 44
Contact retention	Fixed via Epoxy
Contact pitch	0.025 (0.64 mm)

* MIL-STD-202, Method 307, condition A

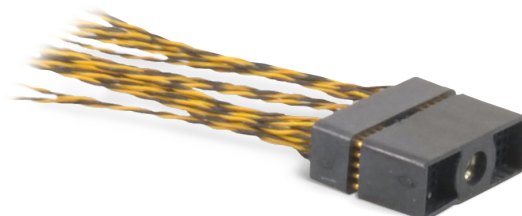

Dimensions shown in inches (mm)
Specifications and dimensions subject to change

Nano Microminiature Center Jackscrew - .030" Contact Spacing



Performance Table

Mechanical, Environmental and Electrical Specifications	
Dielectric Withstanding Voltage	MIL-STD-202, Method 301, condition A
Contact Rating	1 Amp Max.
Wire Accomodation	32 AWG Stranded or 30 AWG Solid
Insulation Resistance	MIL-STD-202, Method 302, condition A
Contact Resistance	Max. 71 millivolts drop with 1 Amp test current in accordance with EIA-364-06
Engagement/Separation Force	<6 oz/contact
Operating Temperature	-65°C to +125°C
Moisture Resistance	MIL-STD-202, Method 106, omit 7B
Vibration	MIL-STD-202, Method 204, condition D
Mechanical Shock	MIL-STD-202, Method 213, condition B
Durability	500 mating/unmating cycles
Salt Spray/Corrosion Resistance	48 hour per MIL-STD-202, Method 101, condition B

Materials and Finish	
Insulators	Polyester
Pin Bundle	Precious Metal per ASTM B477 and ASTM B451, or BeCu per CDA alloy 172 & 102
Pin Sleeve	Nickel Silver per ASTM B122, comp. B, or Cartridge Brass per CDA alloy 260
Socket Contacts	Nickel Silver per ASTM B122, comp. B

Specifications	
Number of Contacts	27, 72 & 266
Contact retention	Fixed via Epoxy
Contact pitch	0.025 (0.64 mm)

Nano Microminiature Center Jackscrew - .030" Contact Spacing



Center Jackscrew/ Rectangular

NJS - 9 & NJS - 24

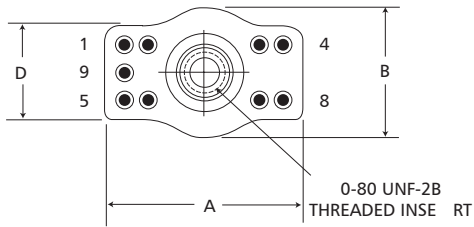

Face View Pin Insert

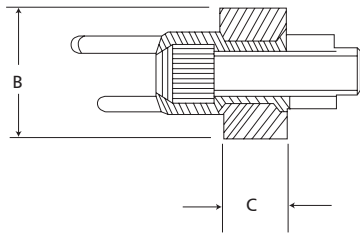

Receptacle Side View

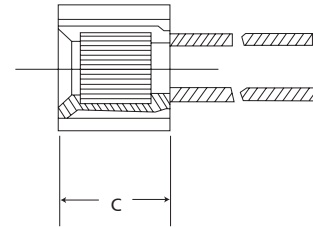

Plug Side View

Part Number	A Max.	B Max.	C ±.005 (0.13)	D ±.005 (0.13)
NJS-9P*	.255 (6.48)	.165 (4.19)	.138 (3.51)	.116 (2.95)
NJS-9S*	.255 (6.48)	.165 (4.19)	.078 (1.98)	.116 (2.95)
NJS-24P*	.435 (11.05)	.165 (4.19)	.138 (3.51)	.116 (2.95)
NJS-24S*	.435 (11.05)	.165 (4.19)	.078 (1.98)	.116 (2.95)
NJSC-266		.165 (4.19)		.116 (2.95)
NJSC-72		.165 (4.19)		.116 (2.95)
NJSC-44		.165 (4.19)		.116 (2.95)
NJSC-27		.165 (4.19)		.116 (2.95)

Dimensions shown in inches (mm)
Specifications and dimensions subject to change

Nano Microminiature Center Jackscrew - .030" Contact Spacing

Contacts

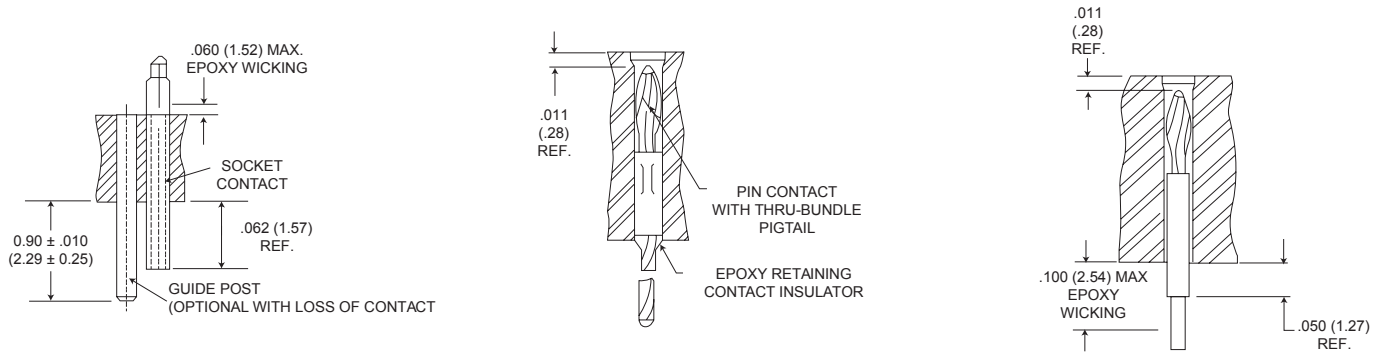

Socket View

Pin View (Thru-Bundle Contact)

Pin View (Crimp-Type Contact)

NOTE: Guide posts can be installed in any contact cavity for polarization purposes.

Connector Saver

NJS - 9 & NJS - 24

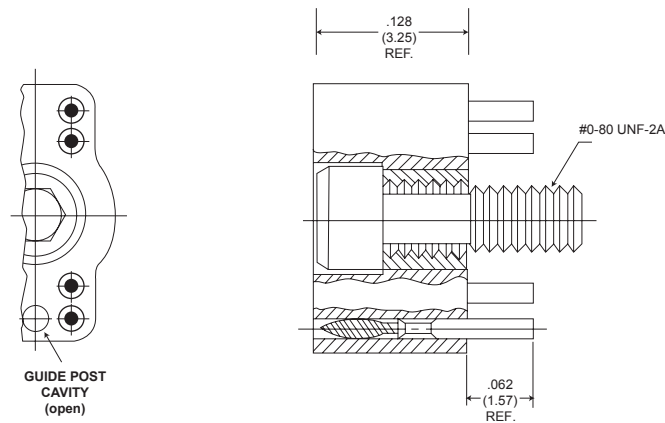

Part Number: NJS97294-835

Dimensions shown in inches (mm)
Specifications and dimensions subject to change

Nano Microminiature

Center Jackscrew - .030" Contact Spacing

L Code Chart

Sorted by Length		
Wire Length, IN.		Code
Decimal	Fraction	
0.080		L63
0.094	3/32	L62
0.110		L65
0.125	1/8	L61
0.140		L67
0.150		L56
0.171		L66
0.187	3/16	L17
0.190		L57
0.210		L59
0.250	1/4	L39
0.312	3/8	L60
0.375	3/8	L58
0.380		L64
0.500	1/2	L1
0.625	5/8	L12
0.750	3/4	L4
1.000		L2
1.500		L7
2.000		L6
2.250		L25
2.500		L16
3.000		L10
3.500		L15
4.000		L11
4.500		L28
5.000		L9
6.000		L3
7.000		L8
8.000		L18
9.000		L45
10.000		L13
11.500		L52
12.000		L4
15.000		L46
18.000		L55
20.000		L5

Sorted by Code		
Code	Wire Length, IN.	
	Decimal	Fraction
L1	0.500	1/2
L2	1.000	
L3	6.000	
L4	12.000	
L5	20.000	
L6	2.000	
L7	1.500	
L8	7.000	
L9	5.000	
L10	3.000	
L11	4.000	
L12	0.625	5/8
L13	10.000	
L14	0.750	3/4
L15	3.500	
L16	2.500	
L17	0.187	3/16
L18	8.000	
L25	2.250	
L28	4.500	
L39	0.250	1/4
L45	9.000	
L46	15.000	
L52	11.500	
L55	18.000	
L56	0.150	
L57	0.190	
L58	0.375	3/8
L59	0.210	
L60	0.312	5/16
L61	.0125	1/8
L62	0.094	3/32
L63	0.080	
L64	0.380	
L65	0.110	
L66	0.171	
L67	0.140	

#30AWG, SOLID COPPER WIRE PER QQ-W-343, TYPE "S", GOLD PLATED PER MIL-G-45204, TYPE II GRADE C OR D, CLASS 1 (50 MICROINCHES MINIMUM)

Dimensions shown in inches (mm)
Specifications and dimensions subject to change

Nano Microminiature

Center Jackscrew - .030" Contact Spacing

H Code Chart

MIL-W-16878/6

Wire, Electrical, Polytetrafluorethylene (PTFE) Insulated,
200 Degrees C, 250 Volts, Extruded Insulation

Length	Yellow	White	System
1	030	C30	A30
2	024	C24	027
3	020	C20	027
4	-	C33	033
5	031	C31	A31
6	019	047	016
8	026	C26	034
9	015	C15	A15
10	029	C29	025
12	028	008	002
16	039	C39	A39
17	036	C36	A36
18	001	044	003
20	038	C38	023
21	055	C55	A55
24	009	045	004
30	010	C10	005
35	018	C18	A18
36	011	058	006
40	037	C37	A37
42	012	021	A12
48	013	C13	048
50	040	C40	A40
60	014	C14	056
72	017	059	046
80	032	C32	A32
92	022	C22	A22
96	035	C35	A35
120	042	C42	041
180	043	C43	A43

Dimensions shown in inches (mm)
Specifications and dimensions subject to change

About ITT Cannon

ITT is a diversified leading manufacturer of highly engineered critical components and customized technology solutions for the energy, transportation and industrial markets. Building on its heritage of innovation, ITT partners with its customers to deliver enduring solutions to the key industries that underpin our modern way of life. Founded in 1920, ITT is headquartered in White Plains, N.Y., with employees in more than 35 countries and sales in a total of approximately 125 countries. For more information visit itt.com

ITT's Cannon brand offers a product portfolio that remains one of the most extensive in the industry. Continuous investment in technology, research and investment have enabled us to provide new, innovative solutions to markets including:

- **Commercial Aerospace**
- **Military & Defense**
- **Industrial**
- **Medical**

Six Sigma Manufacturing

When you specify an ITT Cannon interconnect solution, you can rely on products designed, developed and manufactured to the highest quality and reliability standards. This tradition of excellence is based on ITT's corporate culture of operating its businesses under the principles of Six Sigma. At ITT, Six Sigma is not just a quality philosophy but a complete corporate culture that drives the entire business. Our Value Based Management and Value-Based Product Development systems are two cornerstones that allow for the development of both leadership and product engineering principles.

ITT Cannon operates manufacturing facilities in the United States, Germany, Italy, Mexico, China and Japan, all of which have particular product area strengths that allow ITT Cannon to offer a truly global presence to our customers. Our facilities are world class and accommodate full vertical integration, utilizing the latest manufacturing technologies including automated and robotic machining centers, Super Market manufacturing cells, Kanban pull systems, and automated electrical, mechanical, and optical test and inspection equipment. The combination of our manufacturing strength and our advanced manufacturing facilities allows ITT to offer products at market driven prices. Our capabilities, especially in robotics, computerized precision tooling, Kaizen Project Management, Six Sigma tools and testing give ITT the most optimized global manufacturing footprint in the interconnect industry.

The Custom Difference

As an industry leader in harsh environment interconnect applications, ITT's world class engineering teams work directly with our customers to design and develop cost-effective solutions for their applications. In many cases we may modify one of our standard designs to ensure a highly reliable solution where timing is critical. When custom connectors are required, we collaborate with clients and partners with a goal to design the most reliable, cost-effective solution possible. Our engineering and product management teams provide a thorough analysis of proposed solutions, ensuring our customers receive the right solution for their program and application needs.

RoHS Compliance Information

ITT has implemented a strict parts control plan for all ITT electronics plants worldwide that allows the Cannon product portfolio to meet the requirements of the European Union Directive 2002/95/EC better known as the Reduction of Hazardous Substances initiative. As appropriate, specific Cannon products may be ordered with an R prefix number which insures our customers will receive RoHS compliant parts for their commercial electronics applications and equipment. Since most RoHS hazardous substances center around specific metal plating and lead solder coatings, ITT's products for RoHS compliance are available in the following plating finishes: electroless nickel, stainless steel, anodize over aluminum and gold plating. It should be noted that gold plating would be recommended as the replacement for tin-lead solder when ordering board mount connectors.



Dimensions shown in inches (mm)
Specifications and dimensions subject to change

Product Safety Information

This note must be read in conjunction with the Product Data Sheet / Catalog. Failure to observe the advice in this information sheet and the operating conditions specified in the Product Data Sheet / Catalog could result in hazardous situations.

1. MATERIAL CONTENT & PHYSICAL FORM

Electrical connectors do not usually contain hazardous materials. They contain conducting and non-conducting materials and can be divided into two groups:

- a) Printed circuit types and low cost audio types which employ all plastic insulators and casings.
- b) Rugged, Fire Barrier and High Reliability types with metal casings and either natural rubber, synthetic rubber, plastic or glass insulating materials. Contact materials vary with type of connector and also application and are usually manufactured from either: Copper, copper alloys, nickel, alumel, chromel or steel. In special applications, other alloys may be specified.

2. FIRE CHARACTERISTICS AND ELECTRIC SHOCK HAZARD

There is no fire hazard when the connector is correctly wired and used within the specified parameters.

Incorrect wiring or assembly of the connector or careless use of metal tools or conductive fluids, or transit damage to any of the component parts may cause electric shock or burns. Live circuits must not be broken by separating mated connectors as this may cause arcing, ionization and burning. Heat dissipation is greater at maximum resistance in a circuit. Hot spots may occur when resistance is raised locally by damage, e.g. cracked or deformed contacts, broken strands of wire. Local over-heating may also result from the use of the incorrect application tools or from poor quality soldering or slack screw terminals. Overheating may occur if the ratings in the product Data Sheet/Catalog are exceeded and can cause breakdown of insulation and hence electric shock. If heating is allowed to continue it intensifies by further increasing the local resistance through loss of temper of spring contacts, formation of oxide film on contacts and wires and leakage currents through carbonization of insulation and tracking paths. Fire can then result in the presence of combustible materials and this may release noxious fumes. Overheating may not be visually apparent. Burns may result from touching overheated components.

3. HANDLING

Care must be taken to avoid damage to any component parts of electrical connectors during installation and use. Although there are normally no sharp edges, care must be taken when handling certain components to avoid injury to fingers. Electrical connectors may be damaged in transit to the customers, and damage may result in creation of hazards. Products should therefore be examined prior to installation/use and rejected if found to be damaged.

4. DISPOSAL

Incineration of certain materials may release noxious or even toxic fumes.

5. APPLICATION

Connectors with exposed contacts should not be selected for use on the current supply side of an electrical circuit, because an electric shock could result from touching exposed contacts on an unmated connector. Voltages in excess of 30 V ac or 42.5 V dc are potentially hazardous and care should be taken to ensure that such voltages cannot be transmitted in any way to exposed metal parts of the connector body. The connector and wiring should be checked, before making live, to have no damage to metal parts or insulators, no solder blobs, loose strands, conducting lubricants, swarf, or any other undesired conducting particles. Circuit resistance and continuity check should be made to make certain that there are no high resistance joints or spurious conducting paths. Always use the correct application tools as specified in the Data Sheet/Catalog. Do not permit untrained personnel to wire, assemble or tamper with connectors. For operation voltage please see appropriate national regulations.

IMPORTANT GENERAL INFORMATION

(i) Air and creepage paths/operating voltage. The admissible operating voltages depend on the individual applications and the valid national and other applicable safety regulations. For this reason the air and creepage path data are only reference values. Observe reduction of air and creepage paths due to PC board and/or harnessing.

(ii) Temperature. All information given are temperature limits. The operation temperature depends on the individual application.

(iii) Other important information. Cannon continuously endeavors to improve their products. Therefore, Cannon products may deviate from the description, technical data and shape as shown in this catalog and data sheets.

ITT Cannon is a business unit of ITT Inc., which manufactures the highest quality products available in the marketplace; however these products are intended to be used in accordance with the specifications in this publication. Any use or application that deviates from the stated operating specifications is not recommended and may be unsafe. No information and data contained in this publication shall be construed to create any liability on the part of Cannon. Any new issue of this publication shall automatically invalidate and supersede any and all previous issues

Additional rugged, reliable and proven connector solutions from ITT Cannon

Microminiature Connectors

Developed first by Cannon in the 1960s, Microminiature Connectors offer high performance and reliability with exceptional versatility. Available in rectangular, circular and strip-style configurations, our highly engineered Microminiature connector products meet critical customer demands in multiple applications across the Aerospace & Defense industry.

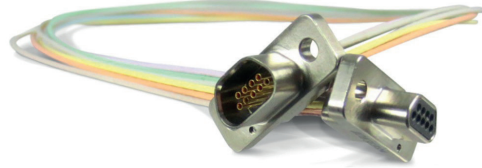

D-Subminiature Connectors

Originally designed for aircraft radio systems, Cannon's D-Subminiature Connector became the first multi-purpose interconnect solution of its kind. From rocket launches and satellite systems, to rugged military transports and commercial avionics, the D-Sub's versatility has made this Cannon invention the most widely used connector in the world.

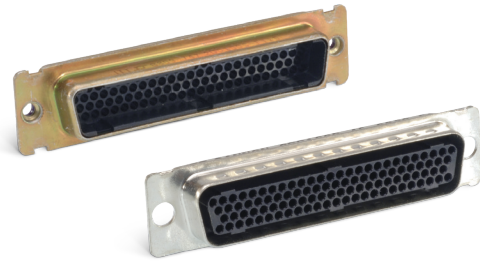

Rack & Panel Interconnect Solutions

Pioneered by Cannon during the 1930s, our Rack & Panel Connectors offer an unmatched variety of shell configurations and insert arrangements, as well as materials, plating and contact options. Today, we are recognized as an industry leader, offering an unparalleled range of off-the-shelf and custom Rack & Panel products to align with customer needs.



cannon

Amazing things
happen when great
things connect



Connect with your ITT Cannon representative today
or visit us at www.ittcannon.com

Connect with the experts

We deliver high performance, harsh environment interconnect solutions that enable the transfer of data, signal and power in an increasingly connected world.

Why ITT

ITT is a focused multi-industrial company that designs and manufactures highly engineered critical components and customized technology solutions. ITT's Cannon brand is a leading global manufacturer of connector products serving international customers in aerospace, defense, medical, industrial and transportation end markets. ITT's Connector business, which also includes the Veam and BIW Connector Systems brand, manufactures and supplies a variety of connectors and interconnects that make it possible to transfer data, signal and power in an increasingly connected world.

Connect with your ITT Cannon representative today or visit us at www.ittcannon.com

Follow us 

CHINA - Shenzhen City
+86.755.2726.7888

GERMANY - Weinstadt
+49.7151.699.0

ITALY - Lainate
+39.02938721

KOREA
+82.2.702.7111

SHANGHAI
+ 86.21.2231.2222.2

UK - Basingstoke
+44.1256.347400

FRANCE
+33.1.60.04.93.93

HONG KONG
+852.2732.2720

JAPAN - Kanagawa
+81.462.57.2010

MEXICO - Nogales
+52.631.311005

SINGAPORE
+65 66974205

USA - Irvine, CA
+1.800.854.3028

X-ON Electronics

Largest Supplier of Electrical and Electronic Components

Click to view similar products for [D-Sub Micro-D Connectors](#) category:

Click to view products by [ITT](#) manufacturer:

Other Similar products are found below :

[89076GBEPR](#) [65-1920-15](#) [M83513/03-G05N](#) [M83513/03-G12N](#) [M83513/04-D11C](#) [M83513/04-G04C](#) [M83513/22-D01NP](#) [664020C06F060](#)
[6R2004A30F015](#) [703006A13F060](#) [704002A03F200](#) [705001A13F120](#) [71-147714-19P](#) [7-1532020-5](#) [748567-1-P](#) [MDB1-31SH003](#) [MDB1-9SH001](#) [MDM-100PH003L](#) [MDM100PH006B](#) [MDM100SH006B](#) [MDM-15PCBRM7T](#) [MDM15PH006LA174](#) [MDM-15PH006P-A174](#)
[MDM-15SH001L](#) [MDM-15SH003A](#) [MDM-15SH004B](#) [MDM-15SH006A-A174](#) [MDM-21PH001F](#) [MDM-21PH003P](#) [MDM21SH003BA174](#)
[MDM21SH003P](#) [MDM-21SH003P-A174](#) [MDM-25PH005K](#) [MDM-25PHW01F-A174](#) [MDM-25SH001F-A174](#) [MDM-25SH003F](#) [MDM-25SH003K](#) [MDM-25SH006K](#) [MDM-31PH006B](#) [MDM31SH001F](#) [MDM-31SH003F](#) [MDM-31SH006F-A174](#) [MDM-31SH006P-A174](#)
[MDM-31SH011F-A174](#) [MDM-31SH011P-A174](#) [MDM-37PH006L-A174](#) [MDM-37PH048M5-A174](#) [MDM-37SCBRP-A174](#) [MDM-37SH003K](#) [MDM-51PH003B-A174](#)