

### Features

- Isolates One Signal in Each Direction
- Operates From 2.7V to 5.5V
- Buffered Inputs - No External LED Drive Required
- Voltage Level Translation
- Hysteresis at Inputs for Noise Rejection
- Slew-Limited Drivers Reduce EMI
- Power-Down to Hi-Z Does Not Load Outputs
- 5Mbaud Data Rate
- 8-Pin DIP or Surface Mount Packages

### Applications

- Isolated Signal Monitoring and Control
- Power-Over-Ethernet
- Power Supply High-Side Interface
- Logic-Level Translation
- Microprocessor System Interface
- Inter-Integrated Circuit (I<sup>2</sup>C) Interface
- Serial Peripheral Interface (SPI)
- Full Duplex Communication
- Isolated Line Receiver
- Isolated Data Acquisition Systems

### Approvals

- UL Recognized Component: File E76270
- EN/IEC 60950: Certificate B 12 11 82667 001



### Description

The CPC5001 is a dual, non-inverting digital optical isolator with buffered-logic inputs and open-drain outputs. Channel 1 propagates a signal from Side A to Side B, while Channel 2 sends a signal from Side B to Side A. It provides galvanic isolation up to 3750V<sub>rms</sub>. When the two sides are powered by supplies with different voltages, it also functions as a logic level translator for supply voltages as low as 2.7V or as high as 5.5V. Available in 8-pin DIP and surface mount packages, it functionally replaces two logic buffers and two single-channel optoisolators. Internal bandgap references regulate the LED drive currents to 3mA to reduce peak power requirements.

Unlike transformer or capacitive isolators, optical isolation passes DC signals, and does not need to be clocked periodically to refresh state. Buffered signals will always return to their proper value after a transient interruption at either side.

### Ordering Information

Part	Description
CPC5001G	8-Pin DIP in Tubes (50 / Tube)
CPC5001GS	8-Pin Surface Mount (50 / Tube)
CPC5001GSTR	8-Pin Surface Mount (1000 / Reel)

Figure 1. CPC5001 Functional Block Diagram

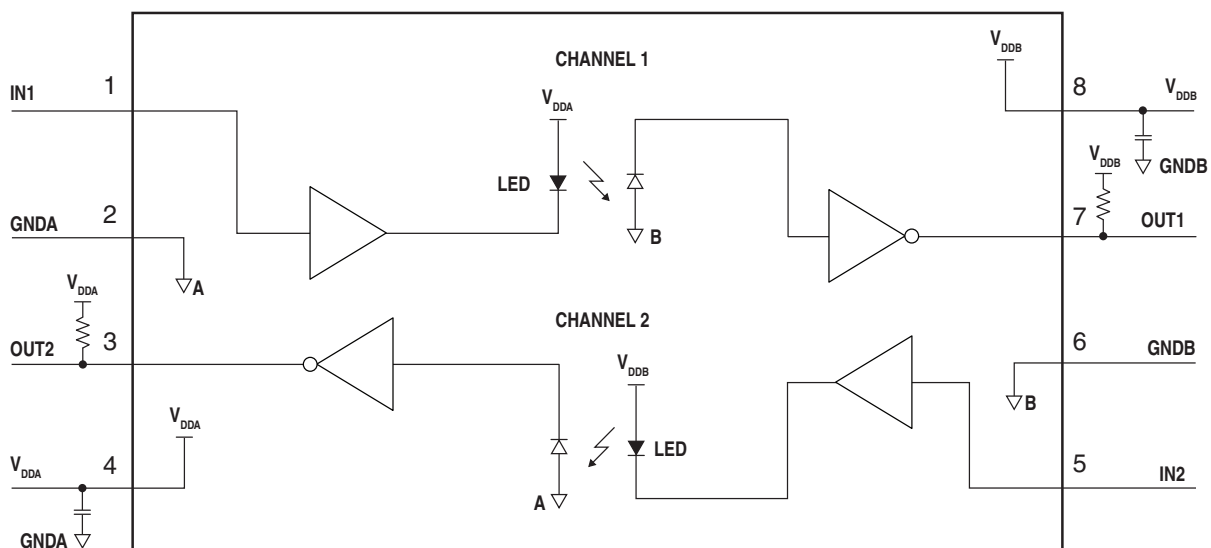

---

<b>1. Specifications</b>	<b>3</b>
1.1 Package Pinout	3
1.2 Pin Description	3
1.3 Absolute Maximum Ratings	3
1.4 ESD Rating	3
1.5 Thermal Characteristics	3
1.6 General Conditions	4
1.7 Electrical Parametric Specifications	4
1.8 Timing Specifications	4
1.9 Common Mode Rejection Specifications	4
<b>2. Switching Waveforms</b>	<b>5</b>
<b>3. Performance Characteristics</b>	<b>6</b>
<b>4. Functional Description</b>	<b>6</b>
4.1 Introduction	6
<b>5. Manufacturing Information</b>	<b>7</b>
5.1 Moisture Sensitivity	7
5.2 ESD Sensitivity	7
5.3 Reflow Profile	7
5.4 Board Wash	7
5.5 Mechanical Dimensions	8

## 1 Specifications

### 1.2 Pin Description

#### 1.1 Package Pinout

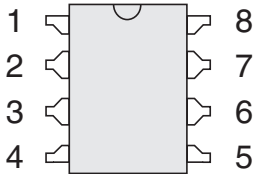

Pin#	Name	Description
1	IN1	Input, Channel 1
2	GNDA	Supply Return - Side A
3	OUT2	Output, Channel 2
4	V <sub>DDA</sub>	Supply Voltage - Side A
5	IN2	Input, Channel 2
6	GNDB	Supply Return - Side B
7	OUT1	Output, Channel 1
8	V <sub>DDB</sub>	Supply Voltage - Side B

#### 1.3 Absolute Maximum Ratings

Electrical Absolute Maximum Ratings are at 25°C. Voltages with respect to local ground: GNDA or GNDB.

Parameter	Symbol	Min	Max	Units
Supply Voltage, Side A	V <sub>DDA</sub>	-0.5	+6.5	V
Supply Voltage, Side B	V <sub>DDB</sub>	-0.5	+6.5	V
Input Voltage	V <sub>IOx</sub>	-0.3	V <sub>DDx</sub> + 0.3	V
Total Package Power Dissipation <sup>1</sup>	P <sub>TOT</sub>	-	800	mW
Isolation Voltage, Input to Output				V <sub>rms</sub>
60 Seconds	-	3750	-	
2 Seconds		4500	-	
Operating Temperature	T <sub>A</sub>	-40	+85	°C
Operating Relative Humidity (Non-condensing)	RH	5	85	%
Storage Temperature	T <sub>STG</sub>	-50	+125	°C

<sup>1</sup> Derate total power by 7.5mW/°C above 25°C.

Absolute maximum ratings are stress ratings. Stresses in excess of these ratings can cause permanent damage to the device. Functional operation of the device at conditions beyond those indicated in the operational sections of this data sheet is not implied.

#### 1.4 ESD Rating

ESD Rating (Human Body Model)
4000V

#### 1.5 Thermal Characteristics

Parameter	Conditions	Symbol	Min	Typ	Max	Units
Thermal Resistance, Junction to Ambient	Free Air	R <sub>θJA</sub>	-	114	-	°C/W

### 1.6 General Conditions

Unless otherwise specified, minimum and maximum values are guaranteed by production testing requirements. Typical values are characteristic of the device at 25°C, and are the result of engineering evaluations. They are provided for information purposes only, and are not part of the manufacturing testing requirements. Specifications cover the operating temperature range  $T_A = -40^{\circ}\text{C}$  to  $+85^{\circ}\text{C}$ , unless otherwise specified.

Side A is the same as Side B, and Channel 1 is the same as Channel 2; therefore, the electrical and timing specifications apply to both Sides/Channels.

### 1.7 Electrical Parametric Specifications

Parameter	Conditions	Symbol	Min	Typ	Max	Units
<b>Electrical</b>						
Supply Voltage	$I_{\text{SINK}}=6\text{mA}$	$V_{\text{DD}}$	2.7	-	5.5	V
Supply Current	$V_{\text{DD}}=3.3\text{V}, I_{\text{SINK}}=0\text{mA}$	$I_{\text{DD}}$	-	4.3	-	mA
	$I_{\text{SINK}}=6\text{mA}$		-	4.4	-	
	$V_{\text{DD}}=5.5\text{V}, I_{\text{SINK}}=0\text{mA}, T_A=25^{\circ}\text{C}$		-	5	7.5	
Leakage Current	$\text{IN1}=\text{OUT2}=\text{V}_{\text{DDA}}, \text{IN2}=\text{OUT1}=\text{V}_{\text{DDB}}$	$I_{\text{LEAK}}$	-	0.01	10	$\mu\text{A}$
Falling Input Low Threshold	$2.7\text{V} \leq V_{\text{DD}} \leq 5.5\text{V}$	$V_{\text{IL}}$	$0.3V_{\text{DD}}$	$0.42V_{\text{DD}}$	-	V
Rising Input High Threshold	$2.7\text{V} \leq V_{\text{DD}} \leq 5.5\text{V}$	$V_{\text{IH}}$	-	$0.57V_{\text{DD}}$	$0.7V_{\text{DD}}$	
Hysteresis	$2.7\text{V} \leq V_{\text{DD}} \leq 5.5\text{V}$	$V_{\text{HYST}}$	-	$0.15V_{\text{DD}}$	-	V
Output Drive	$V_{\text{DD}}=2.7\text{V}, I_{\text{SINK}}=3\text{mA}$	$V_{\text{OL}}$	-	0.21	0.35	V
	$V_{\text{DD}}=2.7\text{V}, I_{\text{SINK}}=6\text{mA}$		-	0.42	0.7	
	$V_{\text{DD}}=3.3\text{V}, I_{\text{SINK}}=6\text{mA}$		-	0.38	-	
Output Temperature Coefficient	$2.7\text{V} \leq V_{\text{DD}} \leq 5.5\text{V}, I_{\text{SINK}}=6\text{mA}$	TC	-	+1.2	-	$\text{mV}/^{\circ}\text{C}$

### 1.8 Timing Specifications

Parameter	Conditions	Symbol	Min	Typ	Max	Units
<b>Timing</b>						
Clock Frequency	$I_{\text{SINK}}=6\text{mA}, C_{\text{LOAD}}=20\text{pF}$	$f_{\text{MAX}}$	-	5	-	MHz
Propagation Delay (see Note 1)	$V_{\text{DDA}}=V_{\text{DDB}}=3.3\text{V}, R_{\text{PUA}}=475\Omega, R_{\text{PUB}}=475\Omega, C_{\text{IN}_A}=C_{\text{IN}_B}=20\text{pF}, V_{\text{IN}}=0.5V_{\text{DD\_IN}} \text{ to } V_{\text{OUT}}=0.5V_{\text{DD\_OUT}}$	$t_{\text{PHL}}$	40	60	100	ns
		$t_{\text{PLH}}$	40	135	250	
Pulse Width Distortion	$t_{\text{PLH}} - t_{\text{PHL}}$	PWD	-25	75	170	ns

Note 1: See “Switching Waveforms” on page 5.

### 1.9 Common Mode Rejection Specifications

Parameter	Conditions	Symbol	Min	Typ	Max	Units		
<b>Common Mode Rejection</b>								
Common Mode Transient Immunity	$V_{\text{CM}}=20V_{\text{P-P}}, V_{\text{DD}}=3.3\text{V}, T_A=25^{\circ}\text{C}$							
		$V_{\text{OUT}} = \text{High}$	$V_{\text{OUT}} > 2\text{V}$	$\text{CM}_{\text{H}}$	5	-	-	$\text{kV}/\mu\text{s}$
		$V_{\text{OUT}} = \text{Low}$	$V_{\text{OUT}} < 0.8\text{V}$	$\text{CM}_{\text{L}}$	7	-	-	

## 2 Switching Waveforms

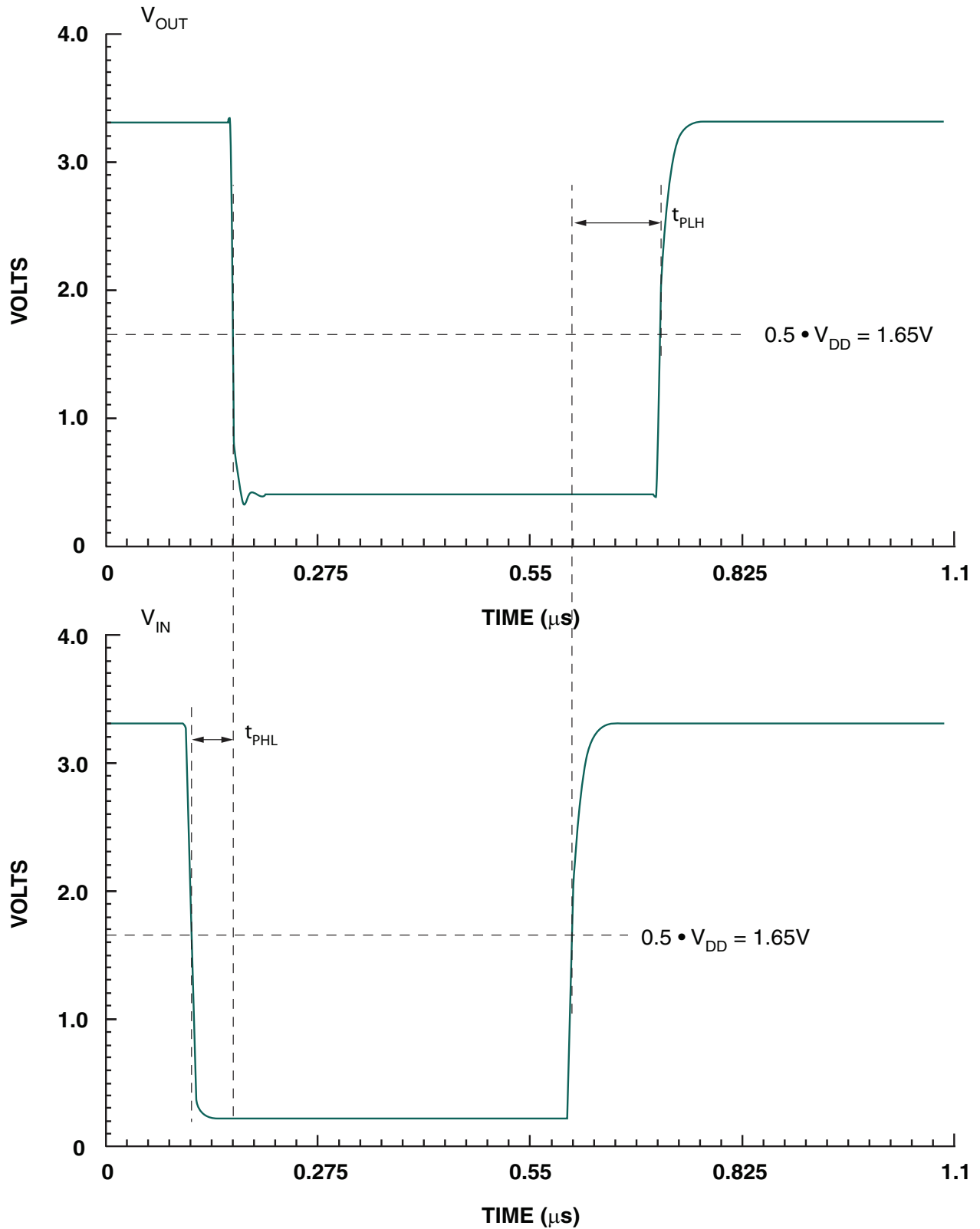

### 3 Performance Characteristics

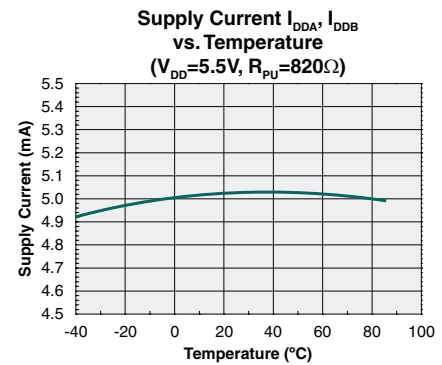
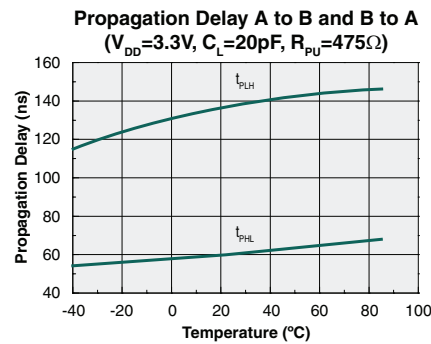
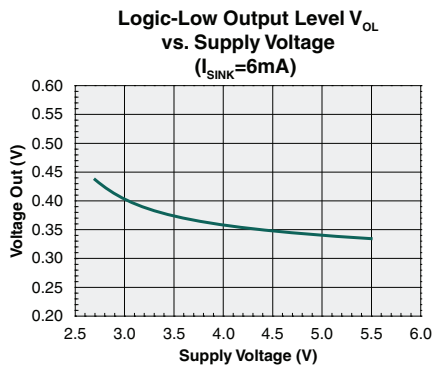
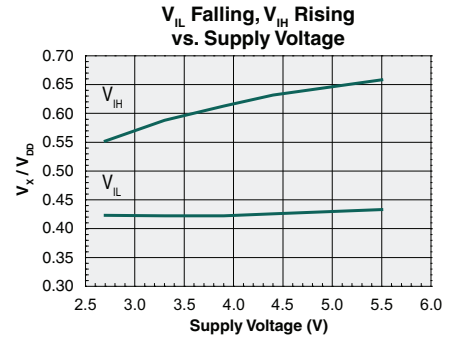
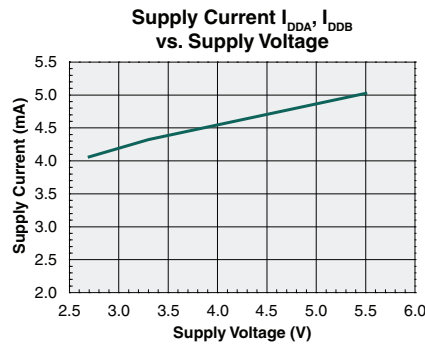
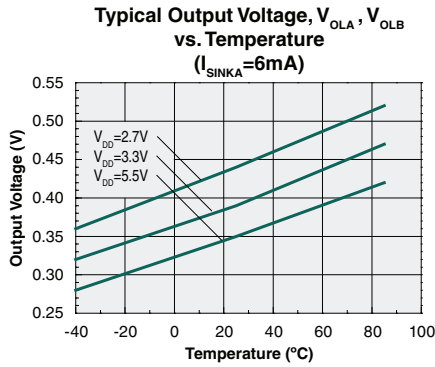

### 4 Functional Description

#### 4.1 Introduction

The CPC5001 combines the functions of two input buffer/LED driver gates and two unidirectional logic optoisolators in a single 8-pin package. The isolators are arranged for one input and one output at each side of the isolation barrier, which enables Channel 1 to send signals from side A to Side B, and Channel 2 to send signals from the Side B to the Side A. If different supply voltage levels are used at each side, then the part, in conjunction with its external pullup resistors, will perform logic level translation for  $V_{DD}$  between 2.7V and 5.5V at either side.

The part provides galvanic isolation for voltages up to  $3750V_{rms}$ . Its CMOS circuitry includes a bandgap reference to ensure that the LEDs receive consistent

drive current levels over the allowed range of  $V_{DD}$  voltages. The supply currents at  $I_{DDA}$  and  $I_{DDB}$  are much smaller than those required by bipolar solutions, and are stable over temperature. The circuits also ensure that the  $I_{DD}$  current into each  $V_{DD}$  package pin remains constant for both high and low input signals. This can greatly reduce the size of external decoupling capacitors when compared with optoisolators fabricated in a bipolar process wherein the supply current can double when the LED is on.

The rotationally symmetric pinout ensures that the part operates normally even if installed with  $180^\circ$  rotation.

## 5 Manufacturing Information

### 5.1 Moisture Sensitivity



All plastic encapsulated semiconductor packages are susceptible to moisture ingress. IXYS Integrated Circuits Division classified all of its plastic encapsulated devices for moisture sensitivity according to the latest version of the joint industry standard, **IPC/JEDEC J-STD-020**, in force at the time of product evaluation. We test all of our products to the maximum conditions set forth in the standard, and guarantee proper operation of our devices when handled according to the limitations and information in that standard as well as to any limitations set forth in the information or standards referenced below.

Failure to adhere to the warnings or limitations as established by the listed specifications could result in reduced product performance, reduction of operable life, and/or reduction of overall reliability.

This product carries a **Moisture Sensitivity Level (MSL) rating** as shown below, and should be handled according to the requirements of the latest version of the joint industry standard **IPC/JEDEC J-STD-033**.

Device	Moisture Sensitivity Level (MSL) Rating
CPC5001G / CPC5001GS	MSL 1

### 5.2 ESD Sensitivity



This product is **ESD Sensitive**, and should be handled according to the industry standard **JESD-625**.

### 5.3 Reflow Profile

This product has a maximum body temperature and time rating as shown below. All other guidelines of **J-STD-020** must be observed.

Device	Maximum Temperature x Time
CPC5001G / CPC5001GS	250°C for 30 seconds

### 5.4 Board Wash

IXYS Integrated Circuits Division recommends the use of no-clean flux formulations. However, board washing to remove flux residue is acceptable. Since IXYS Integrated Circuits Division employs the use of silicone coating as an optical waveguide in many of its optically isolated products, the use of a short drying bake may be necessary if a wash is used after solder reflow processes. Chlorine-based or Fluorine-based solvents or fluxes should not be used. Cleaning methods that employ ultrasonic energy should not be used.



### 5.5 Mechanical Dimensions

#### 5.5.1 CPC5001G Package

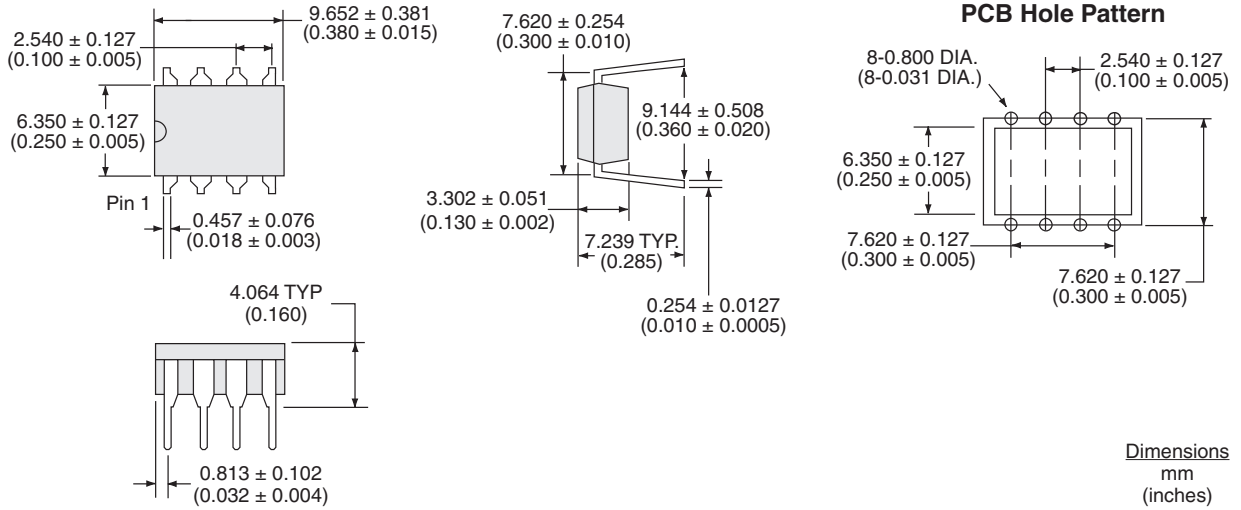

#### 5.5.2 CPC5001GS Package

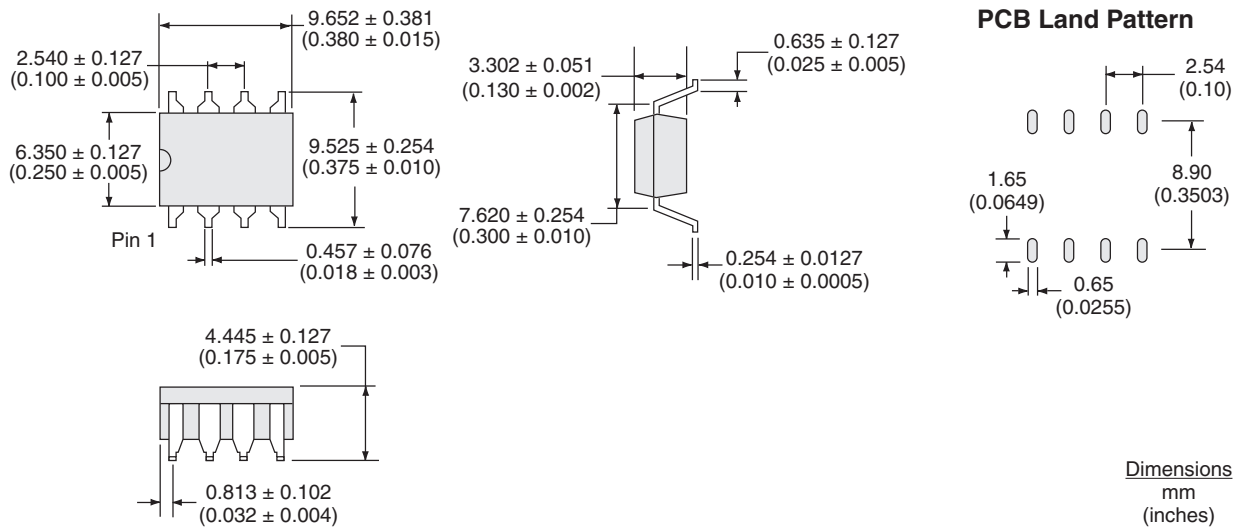



5.5.3 CPC5001GS Tape & Reel Information

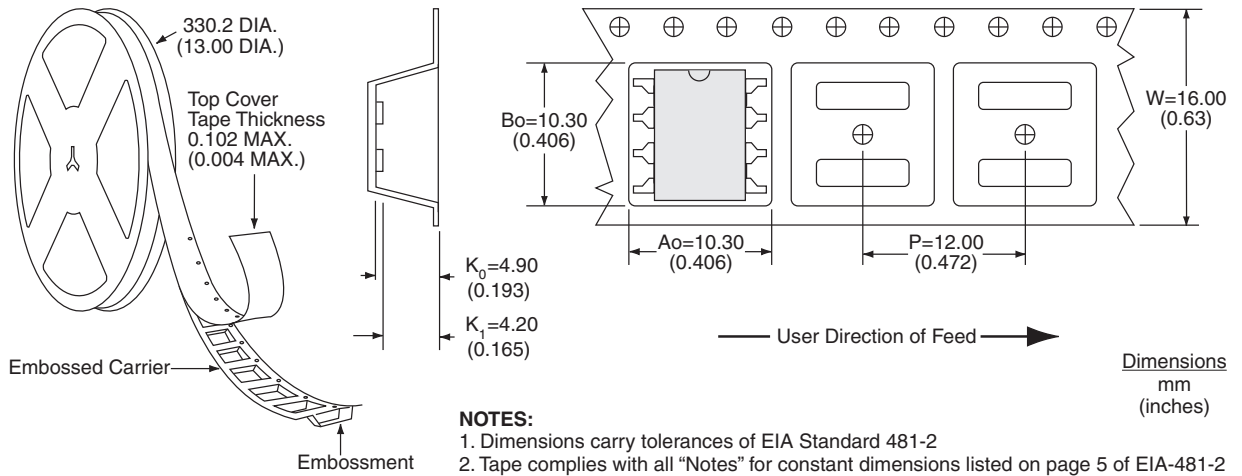

For additional information please visit our website at: [www.ixysic.com](http://www.ixysic.com)

IXYS Integrated Circuits Division makes no representations or warranties with respect to the accuracy or completeness of the contents of this publication and reserves the right to make changes to specifications and product descriptions at any time without notice. Neither circuit patent licenses nor indemnity are expressed or implied. Except as set forth in IXYS Integrated Circuits Division's Standard Terms and Conditions of Sale, IXYS Integrated Circuits Division assumes no liability whatsoever, and disclaims any express or implied warranty, relating to its products including, but not limited to, the implied warranty of merchantability, fitness for a particular purpose, or infringement of any intellectual property right.

The products described in this document are not designed, intended, authorized or warranted for use as components in systems intended for surgical implant into the body, or in other applications intended to support or sustain life, or where malfunction of IXYS Integrated Circuits Division's product may result in direct physical harm, injury, or death to a person or severe property or environmental damage. IXYS Integrated Circuits Division reserves the right to discontinue or make changes to its products at any time without notice.

Specification: DS-CPC5001-R02  
©Copyright 2013, IXYS Integrated Circuits Division  
All rights reserved. Printed in USA.  
12/9/2013

## X-ON Electronics

Largest Supplier of Electrical and Electronic Components

*Click to view similar products for [High Speed Optocouplers](#) category:*

*Click to view products by [IXYS](#) manufacturer:*

Other Similar products are found below :

[HCPL-2201-300](#) [TLP558\(F\)](#) [JAN4N24](#) [610737H](#) [HCPL2630M](#) [HCPL2731SM](#) [HCPL2630SM](#) [PS9817A-1-F3-AX](#) [TLP2766A\(E\)](#)  
[TLP2766A\(LF4,E\)](#) [EL816S2\(C\)\(TU\)-F](#) [TLP281-4](#) [TLP2363\(V4-TPR,E\)](#) [PS9121-F3-AX](#) [PS9123-F3-AX](#) [HCPL2531S](#) [HCPL2631SD](#) [HCPL-](#)  
[4661-500E](#) [TLP118\(TPL,E\)](#) [TLP521-2XGB](#) [TLP621-2XGB](#) [4N46-300E](#) [JANTXV4N24U](#) [SFH6318T](#) [6N135-300E](#) [TIL198](#)  
[TLP2309\(TPL,E\)](#) [TLP2355\(TPL,E\)](#) [TLP521-4GR](#) [TLP521-4XGB](#) [TLP621-4X](#) [TLP621XSM](#) [IS2805-4](#) [IS181GR](#) [ICPL2631](#) [ICPL2630](#)  
[ICPL2601](#) [TLP714\(F\)](#) [TLP754\(F\)](#) [FOD260LSDV](#) [ACPL-064L-500E](#) [PS2501-1XSM](#) [PS2505-1](#) [PS2561L2-1-F3-A](#) [PS2913-1-F3-AX](#)  
[PS9821-2-F3-AX](#) [FOD0721R2](#) [FODM8061R2V](#) [6N135SDM](#) [6N137SDM](#)