

Power Schottky Rectifier ISOPLUS220™

Electrically Isolated Back Surface

$$I_{FAV} = 20 \text{ A}$$

$$V_{RRM} = 100 \text{ V}$$

$$V_F = 0.65 \text{ V}$$

V_{RSM}	V_{RRM}	Type
V	V	
100	100	DSS 20-01AC

Preliminary Data Sheet



ISOPLUS 220™

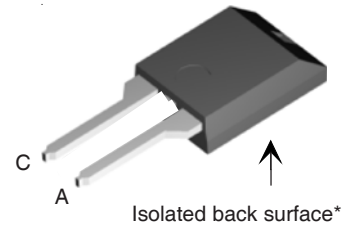

Symbol	Conditions	Maximum Ratings	
I_{FRMS}		35	A
I_{FAV}	$T_C = 140^\circ\text{C}$; rectangular, $d = 0.5$	20	A
I_{FSM}	$T_{VJ} = 45^\circ\text{C}$; $t_p = 10 \text{ ms}$ (50 Hz), sine	120	A
E_{AS}	$I_{AS} = 8 \text{ A}$; $L = 180 \mu\text{H}$; $T_{VJ} = 25^\circ\text{C}$; non repetitive	7	mJ
I_{AR}	$V_A = 1.5 \cdot V_{RRM}$ typical; $f = 10 \text{ kHz}$; repetitive	0.8	A
$(dv/dt)_{cr}$		5000	V/ μs
T_{VJ}		-55...+175	$^\circ\text{C}$
T_{VJM}		175	$^\circ\text{C}$
T_{stg}		-55...+150	$^\circ\text{C}$
T_L	1.6 mm (0.063 in) from case for 10 s	260	$^\circ\text{C}$
P_{tot}	$T_C = 25^\circ\text{C}$	90	W
V_{ISOL}	50/60Hz RMS; $I_{ISOL} < 1 \text{ mA}$	2500	V~
F_C	Mounting force	11... 65 / 2.4 ...11	N/lb
Weight	typical	3	g

Features

- Silicon chip on Direct-Copper-Bond substrate
 - High power dissipation
 - Isolated mounting surface
 - 2500V electrical isolation
- Low cathode to tab capacitance (<15pF)
- International standard package
- Very low V_F
- Extremely low switching losses
- Low I_{RM} -values
- Epoxy meets UL 94V-0

Applications

- Rectifiers in switch mode power supplies (SMPS)
- Free wheeling diode in low voltage converters

Advantages

- High reliability circuit operation
- Low voltage peaks for reduced protection circuits
- Low noise switching
- Low losses

See DSS 20-01A data sheet for characteristic curves

Symbol	Conditions	Characteristic Values	
		typ.	max.
I_R ①	$T_{VJ} = 25^\circ\text{C}$ $V_R = V_{RRM}$		300 μA
	$T_{VJ} = 125^\circ\text{C}$ $V_R = V_{RRM}$		2.5 mA
V_F ②	$I_F = 10 \text{ A}$; $T_{VJ} = 125^\circ\text{C}$		0.65 V
	$I_F = 10 \text{ A}$; $T_{VJ} = 25^\circ\text{C}$		0.80 V
	$I_F = 20 \text{ A}$; $T_{VJ} = 125^\circ\text{C}$		0.76 V
R_{thJC}		0.6	1.7 K/W
R_{thCH}			K/W

Note: See DSS 16-01A for electrical characteristic curves.

Pulse test: ① Pulse Width = 5 ms, Duty Cycle < 2.0 %
 ② Pulse Width = 300 μs , Duty Cycle < 2.0 %

IXYS reserves the right to change limits, conditions and dimensions.

DS98787(07/03)

ISOPLUS220 Outline (2 leads)

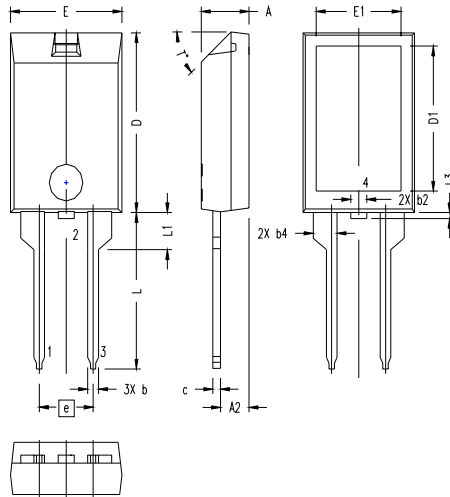

SYM	INCHES		MILLIMETERS	
	MIN	MAX	MIN	MAX
A	.157	.197	4.00	5.00
A2	.098	.118	2.50	3.00
b	.035	.051	0.90	1.30
b2	.049	.065	1.25	1.65
b4	.093	.100	2.35	2.55
c	.028	.039	0.70	1.00
D	.591	.630	15.00	16.00
D1	.472	.512	12.00	13.00
E	.394	.433	10.00	11.00
E1	.295	.335	7.50	8.50
e	.200 BASIC		5.08 BASIC	
L	.512	.571	13.00	14.50
L1	.118	.138	3.00	3.50
L3	.000	.059	0.00	1.50
T*			42.5°	47.5°

NOTE:
 1. Bottom heatsink (Pin 4) is electrically isolated from Pin 1, 2, or 3.

Power Schottky Rectifier ISOPLUS220™

Electrically Isolated Back Surface

$$I_{FAV} = 20 \text{ A}$$

$$V_{RRM} = 100 \text{ V}$$

$$V_F = 0.65 \text{ V}$$

V_{RSM}	V_{RRM}	Type
V	V	
100	100	DSS 20-01AC

Preliminary Data Sheet



ISOPLUS 220™

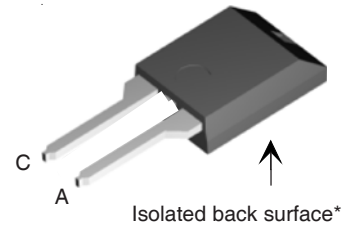

Symbol	Conditions	Maximum Ratings	
I_{FRMS}		35	A
I_{FAV}	$T_C = 140^\circ\text{C}$; rectangular, $d = 0.5$	20	A
I_{FSM}	$T_{VJ} = 45^\circ\text{C}$; $t_p = 10 \text{ ms}$ (50 Hz), sine	120	A
E_{AS}	$I_{AS} = 8 \text{ A}$; $L = 180 \mu\text{H}$; $T_{VJ} = 25^\circ\text{C}$; non repetitive	7	mJ
I_{AR}	$V_A = 1.5 \cdot V_{RRM}$ typical; $f = 10 \text{ kHz}$; repetitive	0.8	A
$(dv/dt)_{cr}$		5000	V/ μs
T_{VJ}		-55...+175	$^\circ\text{C}$
T_{VJM}		175	$^\circ\text{C}$
T_{stg}		-55...+150	$^\circ\text{C}$
T_L	1.6 mm (0.063 in) from case for 10 s	260	$^\circ\text{C}$
P_{tot}	$T_C = 25^\circ\text{C}$	90	W
V_{ISOL}	50/60Hz RMS; $I_{ISOL} < 1 \text{ mA}$	2500	V~
F_C	Mounting force	11... 65 / 2.4 ...11	N/lb
Weight	typical	3	g

Symbol	Conditions	Characteristic Values	
		typ.	max.
I_R ①	$T_{VJ} = 25^\circ\text{C}$ $V_R = V_{RRM}$		300 μA
	$T_{VJ} = 125^\circ\text{C}$ $V_R = V_{RRM}$		2.5 mA
V_F ②	$I_F = 10 \text{ A}$; $T_{VJ} = 125^\circ\text{C}$		0.65 V
	$I_F = 10 \text{ A}$; $T_{VJ} = 25^\circ\text{C}$		0.80 V
	$I_F = 20 \text{ A}$; $T_{VJ} = 125^\circ\text{C}$		0.76 V
R_{thJC}		0.6	1.7 K/W
R_{thCH}			K/W

Note: See DSS 16-01A for electrical characteristic curves.

Pulse test: ① Pulse Width = 5 ms, Duty Cycle < 2.0 %
 ② Pulse Width = 300 μs , Duty Cycle < 2.0 %

IXYS reserves the right to change limits, conditions and dimensions.

© 2003 IXYS All rights reserved

Features

- Silicon chip on Direct-Copper-Bond substrate
 - High power dissipation
 - Isolated mounting surface
 - 2500V electrical isolation
- Low cathode to tab capacitance (<15pF)
- International standard package
- Very low V_F
- Extremely low switching losses
- Low I_{RM} -values
- Epoxy meets UL 94V-0

Applications

- Rectifiers in switch mode power supplies (SMPS)
- Free wheeling diode in low voltage converters

Advantages

- High reliability circuit operation
- Low voltage peaks for reduced protection circuits
- Low noise switching
- Low losses

See DSS 20-01A data sheet for characteristic curves

ISOPLUS220 Outline (2 leads)

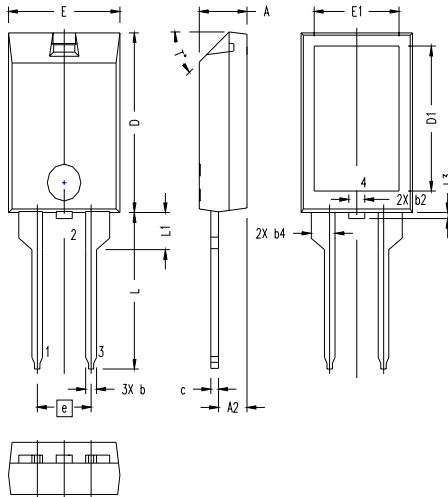

SYM	INCHES		MILLIMETERS	
	MIN	MAX	MIN	MAX
A	.157	.197	4.00	5.00
A2	.098	.118	2.50	3.00
b	.035	.051	0.90	1.30
b2	.049	.065	1.25	1.65
b4	.093	.100	2.35	2.55
c	.028	.039	0.70	1.00
D	.591	.630	15.00	16.00
D1	.472	.512	12.00	13.00
E	.394	.433	10.00	11.00
E1	.295	.335	7.50	8.50
e	.200 BASIC		5.08 BASIC	
L	.512	.571	13.00	14.50
L1	.118	.138	3.00	3.50
L3	.000	.059	0.00	1.50
T*			42.5°	47.5°

NOTE:
 1. Bottom heatsink (Pin 4) is electrically isolated from Pin 1, 2, or 3.

X-ON Electronics

Largest Supplier of Electrical and Electronic Components

Click to view similar products for [Schottky Diodes & Rectifiers](#) category:

Click to view products by [IXYS](#) manufacturer:

Other Similar products are found below :

[CUS06\(Te85L,Q,M\)](#) [D1FH3-5063](#) [MBR0530L-TP](#) [MBR10100CT-BP](#) [MBR30H100MFST1G](#) [MMBD301M3T5G](#) [PMAD1103-LF](#)
[PMAD1108-LF](#) [RB160M-50TR](#) [RB520S-30](#) [RB551V-30](#) [DD350N18K](#) [DZ435N40K](#) [DZ600N16K](#) [BAS16E6433HTMA1](#) [BAS 3010S-](#)
[02LRH E6327](#) [BAT 54-02LRH E6327](#) [IDL02G65C5XUMA1](#) [NSR05F40QNXT5G](#) [JANS1N6640](#) [SB07-03C-TB-H](#) [SB1003M3-TL-W](#)
[SBAT54CWT1G](#) [SBM30-03-TR-E](#) [SK32A-LTP](#) [SK33A-TP](#) [SK34A-TP](#) [SK34B-TP](#) [SMD1200PL-TP](#) [ACDBN160-HF](#) [SS3003CH-TL-E](#)
[STPS30S45CW](#) [PDS3100Q-7](#) [GA01SHT18](#) [CRS10I30A\(Te85L,QM\)](#) [MBR1240MFST1G](#) [MBRB30H30CT-1G](#) [BAS28E6433HTMA1](#) [BAS](#)
[70-02L E6327](#) [HSB123JTR-E](#) [JANTX1N5712-1](#) [VS-STPS40L45CW-N3](#) [DD350N12K](#) [SB007-03C-TB-E](#) [SB10015M-TL-E](#) [SB1003M3-TL-](#)
[E](#) [SK110-LTP](#) [SK154-TP](#) [SK32A-TP](#) [SK33B-TP](#)