

Features

- High Output Current: 2A Source/4A Sink
- Wide Operating Voltage Range: -10V to +26V
- Negative Gate Drive Capability
- Desaturation Detection Circuit
- Separate Source and Sink Outputs
- Programmable Blanking and Output Tristate
- TTL Compatible Inputs
- -40°C to +125°C Extended Operating Temperature Range
- Under-Voltage Lockout Circuitry
- Fault Status Output

Applications

- Efficient IGBT Switching
- Motor Controls
- Switch Mode Power Supplies

Description

The IX2204 is a dual high current gate driver specifically designed to drive the gates of high current IGBTs. The IX2204 provides two high current outputs capable of sourcing 2A and sinking 4A. The outputs can be paralleled for IGBT gates that require higher drive current. The outputs have a wide operating voltage range, and are able to provide a negative gate drive voltage to ensure the turn-off of high power IGBTs. A desaturation detection circuit protects the power IGBT during a short circuit. The IX2204 has a programmable two-level turn-off feature that protects the device against excessive voltages when the IGBT is being turned off due to an over-current situation.

The IX2204 has under voltage lockout circuitry and a fault status output, and is available in a 16-lead thermally enhanced SOIC package.

Ordering Information

Part	Description
IX2204NE	16-Pin SOIC in Tubes (50/Tube)
IX2204NETR	16-Pin SOIC in Tape & Reel (2000/Reel)



IX2204 Functional Block Diagram

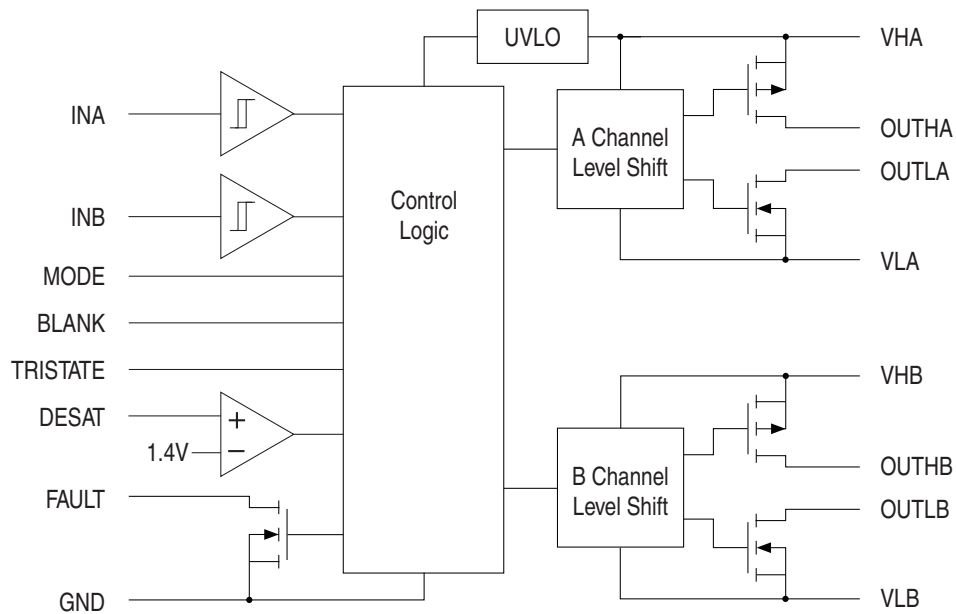

1. Specifications	3
1.1 Package Pinout: 16-Pin SOIC Package	3
1.2 Pin Description: 16-Pin SOIC Package	3
1.3 Absolute Maximum Ratings	4
1.4 Recommended Operating Conditions	4
1.5 DC Electrical Characteristics	4
1.6 AC Electrical Characteristics	5
1.7 Thermal Characteristics	5
1.8 AC Input/Output Timing Diagram (MODE=0V)	5
1.9 AC Fault Timing Diagram	5
2. Performance Characteristics	6
3. Functional Description	7
3.1 Input	7
3.2 Mode	7
3.3 Desaturation Protection	7
3.4 Under-Voltage Protection	7
3.5 Fault Output	7
3.6 Outputs	7
4. Application Drawings	8
4.1 Parallel-Mode IGBT Drive with Desaturation Detection	8
4.2 Direct IGBT Drive	8
4.3 Stack-Mode IGBT Drive with Desaturation Detection	8
5. Manufacturing Information	9
5.1 Moisture Sensitivity	9
5.2 ESD Sensitivity	9
5.3 Reflow Profile	9
5.4 Board Wash	9
5.5 Mechanical Dimensions	10

1 Specifications

1.1 Package Pinout: 16-Pin SOIC Package

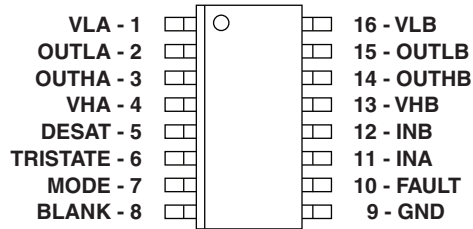

1.2 Pin Description: 16-Pin SOIC Package

Pin#	Name	Description
1	VLA	Channel A negative supply
2	OUTLA	Channel A sinking output
3	OUTH A	Channel A sourcing output
4	VHA	Channel A positive supply & logic supply
5	DESAT	Desaturation comparator input
6	TRISTATE	Channel A tristate timing
7	MODE	Mode control
8	BLANK	Channel A start-up blanking time
9	GND	Signal ground
10	FAULT	Fault status output
11	INA	Channel A logic input
12	INB	Channel B logic input
13	VHB	Channel B positive Supply
14	OUTH B	Channel B sourcing output
15	OUTLB	Channel B sinking output
16	VLB	Channel B negative supply

1.3 Absolute Maximum Ratings

Parameter	Symbol	Minimum	Maximum	Units
VH Supply Voltage ¹	VHA, VHB	-	26	V
VL Supply Voltage	VLA, VLB	-10	-	V
Supply Voltage All Other Pins	-	GND-0.3	VHA+0.3	V
Output Sourcing Current	I _{OUTH}	-	-2	A
Output Sinking Current	I _{OUTL}	-	4	A
Junction Temperature	T _J	-55	+150	°C
Storage Temperature	T _{STG}	-65	+150	°C

Note 1: VHx-VLx maximum is 26V.

1.4 Recommended Operating Conditions

Parameter	Symbol	Minimum	Maximum	Units
VH Supply Voltage	VHA, VHB	-	25	V
VL Supply Voltage	VLA, VLB	-10	GND	V
Operating Temperature Range	T _A	-40	+125	°C

1.5 DC Electrical Characteristics

13V ≤ VHA ≤ 25V; 13V ≤ VHB ≤ 25V; -40°C ≤ T_A ≤ 125°C.

Parameter	Conditions	Symbol	Minimum	Typical	Maximum	Units
Power Supply Current	VHA=18V	I _{VHA}	-	-	3.5	mA
Under-Voltage Lockout Output Enable Threshold	VHA Rising	UVLO ₊	10	-	13	V
Under-Voltage Lockout Output Hysteresis	-	UVLO _{HYS}	-	1	-	V
INA / INB Logic Low Threshold	-	V _{IL}	0.8	-	-	V
INA / INB Logic High Threshold	-	V _{IH}	-	-	2	V
INA / INB / MODE Input Current	-	I _{IN}	-	-	1	μA
DESAT Threshold	-	V _{DESAT}	1.26	1.4	1.54	V
TRISTATE / BLANK Source Current	-	I _{SRC}	-100	-160	-210	μA
FAULT Output						
FAULT Low Voltage	I _{FAULT} =8mA	V _{FAULT}	-	-	0.8	V
Outputs						
Low Output Voltage	No Load	V _{OUTL}	-	-	VL+0.025	V
High Output Voltage	No Load	V _{OUTH}	VH-0.025	-	-	V
Output Resistance	VH=18V, I _{OUTH} = -100mA	R _{OUTH}	-	2.4	5	Ω
	VH=18V, I _{OUTL} = 100mA	R _{OUTL}	-	1.2	2	Ω

1.6 AC Electrical Characteristics

13V ≤ VHA ≤ 25V; -40°C ≤ T_A ≤ 125°C

Parameter	Conditions	Symbol	Minimum	Typical	Maximum	Units
OUT Rise Time	VH=18V, C _{LOAD} =1nF	t _r	-	-	40	ns
OUT Fall Time		t _f	-	8	20	
Delay, IN to OUT Rising		TDLH	-	70	100	
Delay, IN to OUT Falling		TDHL	-	70	100	
IN to OUT Pulse Distortion	(tw _{in} - tw _{out}), C _{LOAD} =0	Δtw	-	7	25	ns
	(tw _{in} - tw _{out}), C _{LOAD} =1nF		-	7	25	
DESAT Blank Time	C _{BLANK} =0	t _{BLANK}	-	-	100	ns
	C _{BLANK} =100pF		-	875	-	
Delay Time, DESAT to Output Tristate	R _L =100Ω to GND	t _{DELAY1}	-	50	100	ns
Duration of Tristate OUT	C _{TRISTATE} =0	t _{TRISTATE}	-	-	100	ns
	C _{TRISTATE} =100pF		-	1000	-	
Delay Time, TRISTATE high to OUT Low	VH=18V, C _{LOAD} =1nF	t _{DELAY2}	-	-	100	ns

1.7 Thermal Characteristics

Parameter	Symbol	Rating	Units
Thermal Resistance, Junction to Ambient	θ _{JA}	75.4	°C/W

1.8 AC Input/Output Timing Diagram (MODE=0V)

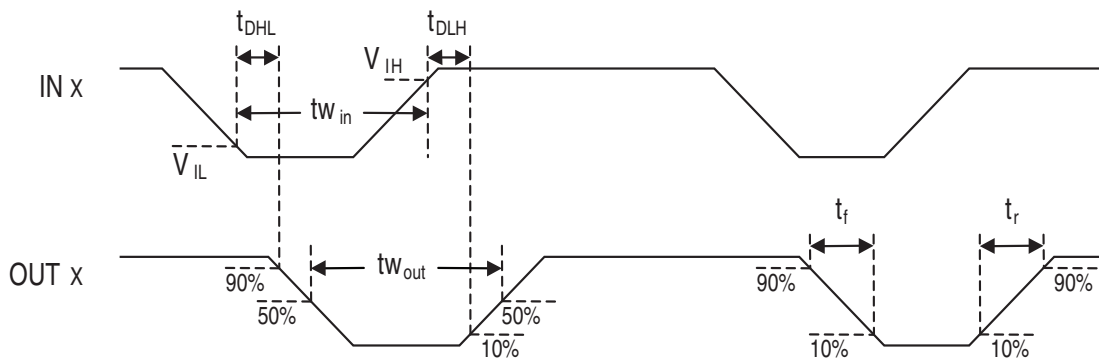

1.9 AC Fault Timing Diagram

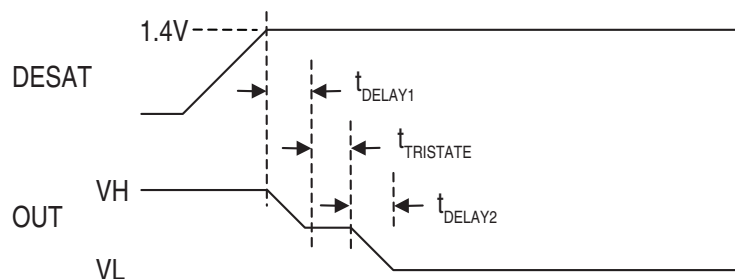

2 Performance Characteristics

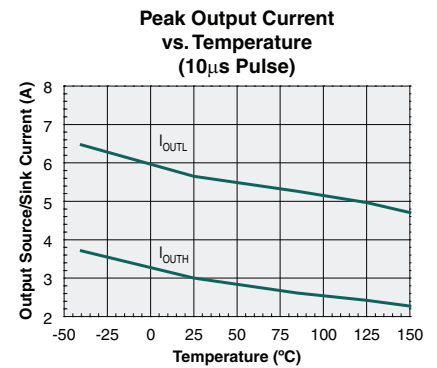
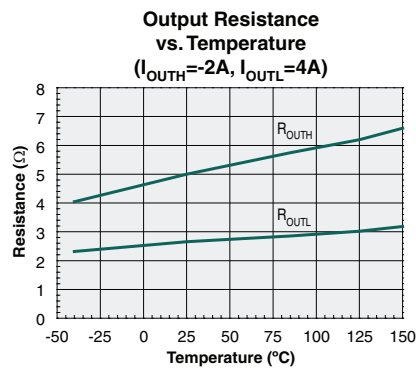
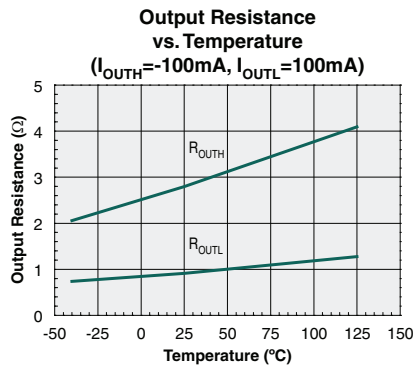
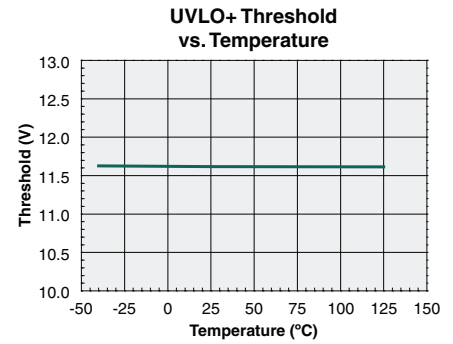
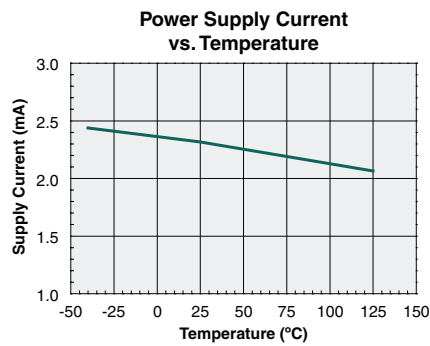
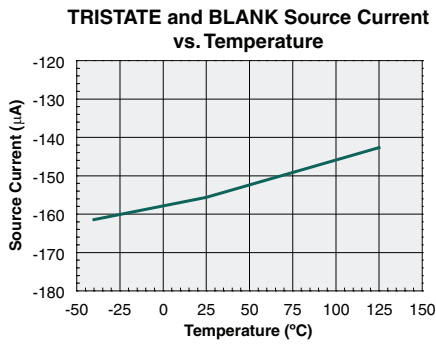
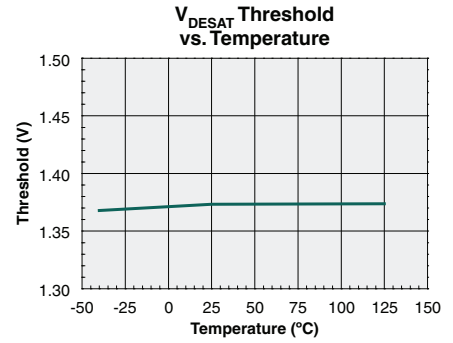
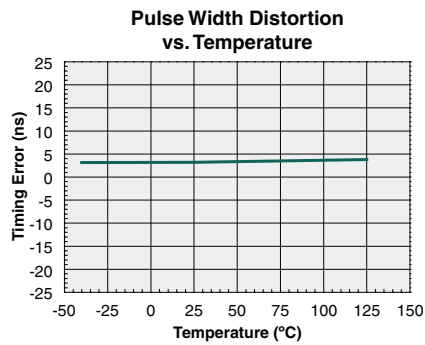
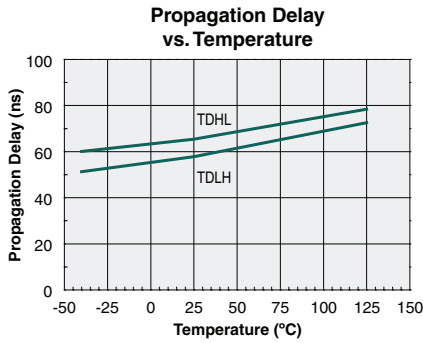

3 Functional Description

3.1 Input

The INA and INB inputs are TTL compatible and must be referenced to GND.

3.2 Mode

The MODE input determines how the INA and INB inputs control the outputs. MODE should be connected directly to GND or VHA depending on the application requirements (see Table 1 below)

Table 1:

Mode	INA / INB	OUTHA / OUTHB	OUTLA / OUTLB
GND	1	1	Z
GND	0	Z	0
VHA	1	Z	0
VHA	0	1	Z

When MODE is connected to VHA, external drive transistors can be used for driving IGBTs that require higher gate drive current than the IX2204 can supply. In this stacked configuration, it is assumed that these external drive transistors constitute an inverting stage.

3.3 Desaturation Protection

The desaturation protection circuit ensures the protection of an external IGBT in the event of an over-current situation. When the voltage at DESAT exceeds 1.4V (typically), OUTLA and OUTLB are driven low in a two-step process. First, both OUTHx and OUTLx are tristated, then OUTLx transitions low. This action avoids both dangerous over-voltages across the IGBT and reverse-bias SOA problems, especially during a short circuit turn-off. The time that both OUTHx and OUTLx are in tristate is set by an internal current source and an external capacitor (C_{TRISTATE}), that is connected to the TRISTATE pin. The tristate time is approximately:

$$t_{TRISTATE} = 8750 \cdot C_{TRISTATE}$$

The desaturation circuit is disabled for a fixed blanking time to avoid detecting a false desaturation event during IGBT turn-on, thus allowing enough time for

IGBT saturation. This blanking time is set by an internal current source and an external capacitor, C_{BLK}. The blanking time is approximately:

$$t_{BLK} = 8750 \cdot C_{BLK}$$

The blanking time starts when INA transitions to turn on OUTHA (INA going H with MODE connected to GND, or INA going L with MODE connected to VHA).

The desaturation protection circuit cannot be used when the IX2204 is used to drive two separate IGBTs (direct IGBT drive). When driving two separate IGBTs, the DESAT, TRISTATE, MODE, and BLANK pins should all be connected to GND.

3.4 Under-Voltage Protection

The Under Voltage Lock Out (UVLO) circuit protects the IGBT from insufficient gate voltage. The UVLO circuit monitors the VHA supply voltage. If VHA is below the UVLO+ threshold and MODE is connected to GND, OUTHA and OUTHB are turned-off (high impedance), and both OUTLA and OUTLB are turned on (pulled low). If VHA is below the UVLO+ threshold and MODE is connected to VHA, OUTHA and OUTHB are turned on, and OUTLA and OUTLB are turned off.

Table 2: Output States with VHA < UVLO+

Mode	OUTHA	OUTLA	OUTHB	OUTLB
GND	Z	0	Z	0
VHA	1	Z	1	Z

3.5 Fault Output

The FAULT output is pulled low during a desaturation event, or when VHA is below UVLO+.

3.6 Outputs

The output stages are able to source 2A, and sink 4A. Separated sink and source outputs allow independent gate charge and discharge control. For higher gate drive applications, the source and sink outputs can be paralleled to source 4A, and sink 8A.

4 Application Drawings

4.1 Parallel-Mode IGBT Drive with Desaturation Detection

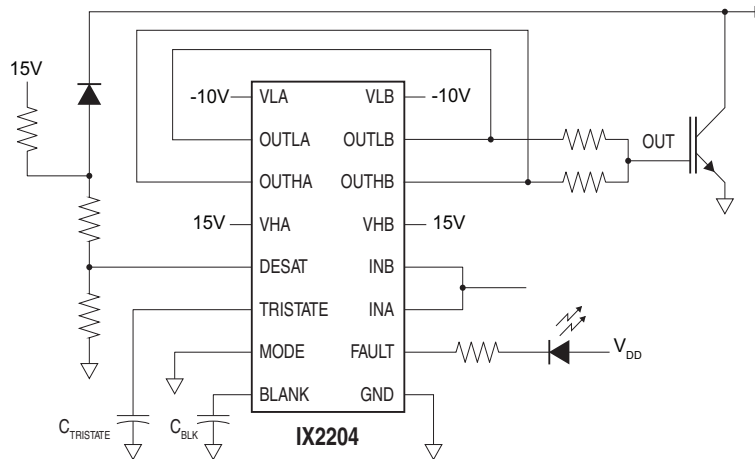

4.2 Direct IGBT Drive

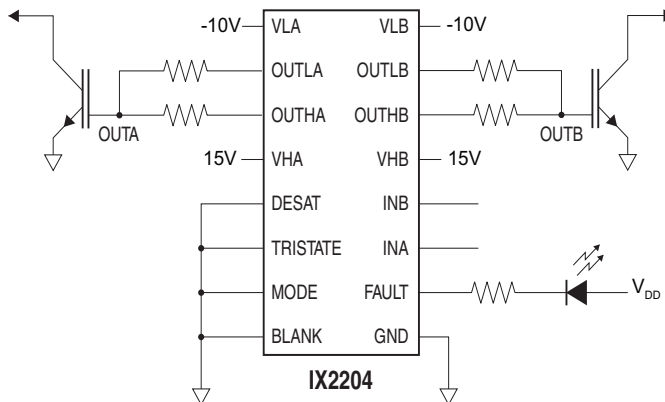

4.3 Stack-Mode IGBT Drive with Desaturation Detection

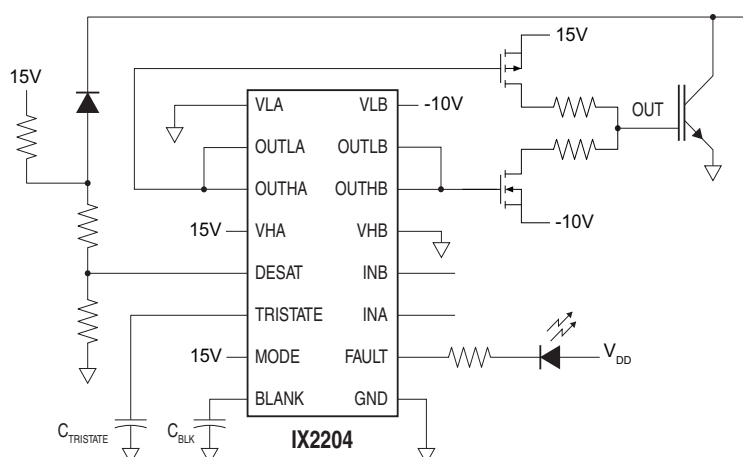

5 Manufacturing Information

5.1 Moisture Sensitivity



All plastic encapsulated semiconductor packages are susceptible to moisture ingress. IXYS Integrated Circuits Division classified all of its plastic encapsulated devices for moisture sensitivity according to the latest version of the joint industry standard, **IPC/JEDEC J-STD-020**, in force at the time of product evaluation. We test all of our products to the maximum conditions set forth in the standard, and guarantee proper operation of our devices when handled according to the limitations and information in that standard as well as to any limitations set forth in the information or standards referenced below.

Failure to adhere to the warnings or limitations as established by the listed specifications could result in reduced product performance, reduction of operable life, and/or reduction of overall reliability.

This product carries a **Moisture Sensitivity Level (MSL) rating** as shown below, and should be handled according to the requirements of the latest version of the joint industry standard **IPC/JEDEC J-STD-033**.

Device	Moisture Sensitivity Level (MSL) Rating
IX2204NE	MSL 1

5.2 ESD Sensitivity



This product is **ESD Sensitive**, and should be handled according to the industry standard **JESD-625**.

5.3 Reflow Profile

This product has a maximum body temperature and time rating as shown below. All other guidelines of **J-STD-020** must be observed.

Device	Maximum Temperature x Time
IX2204NE	260°C for 30 seconds

5.4 Board Wash

IXYS Integrated Circuits Division recommends the use of no-clean flux formulations. However, board washing to remove flux residue is acceptable, and the use of a short drying bake may be necessary. Chlorine-based or Fluorine-based solvents or fluxes should not be used. Cleaning methods that employ ultrasonic energy should not be used.



5.5 Mechanical Dimensions

5.5.1 IX2204NE 16-Pin Narrow SOIC Package

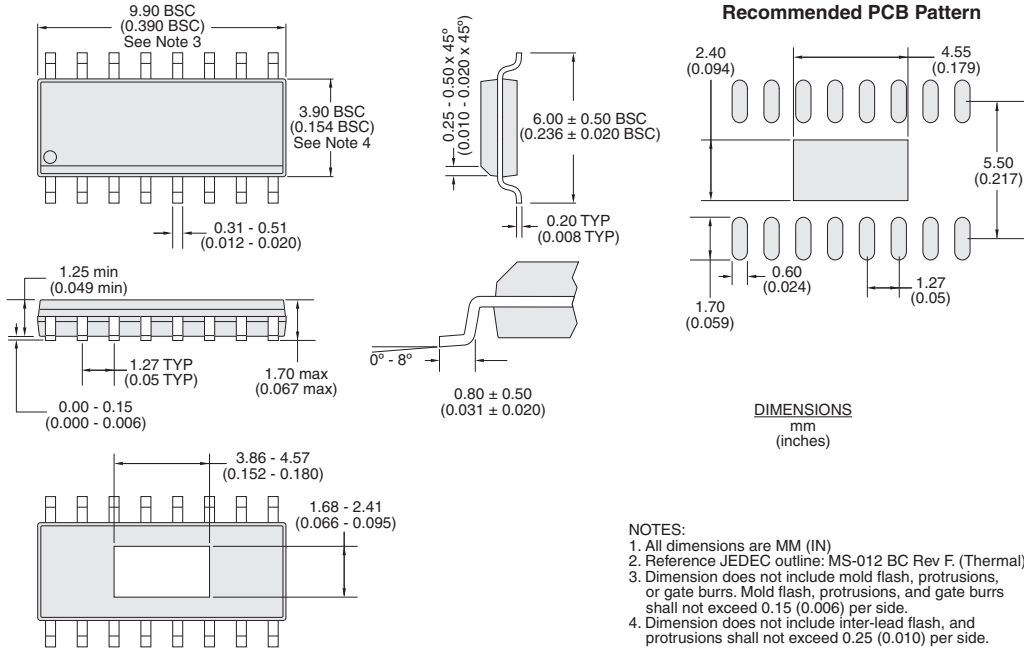

5.5.2 IX2204NETR Tape & Reel Packaging for 16-Pin Narrow SOIC Package (TBD)

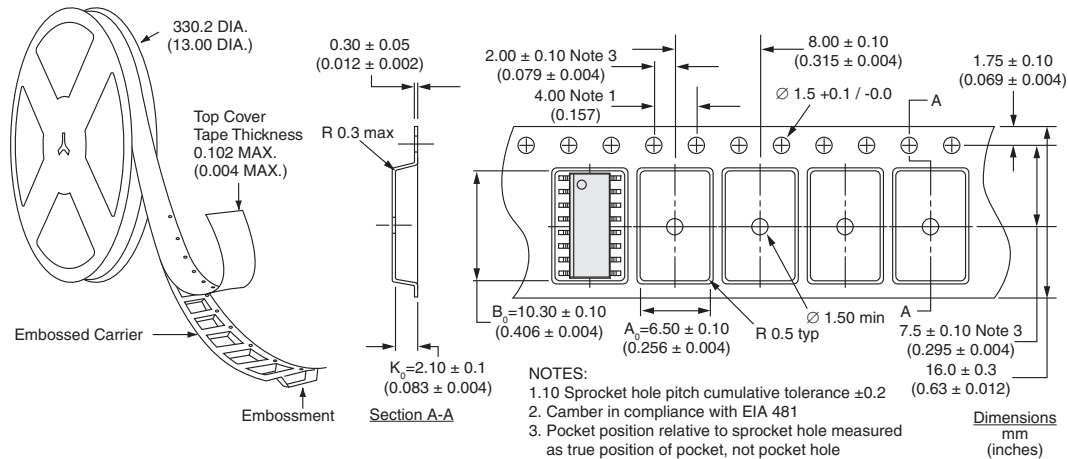

For additional information please visit our website at: www.ixysic.com

IXYS Integrated Circuits Division makes no representations or warranties with respect to the accuracy or completeness of the contents of this publication and reserves the right to make changes to specifications and product descriptions at any time without notice. Neither circuit patent licenses nor indemnity are expressed or implied. Except as set forth in IXYS Integrated Circuits Division's Standard Terms and Conditions of Sale, IXYS Integrated Circuits Division assumes no liability whatsoever, and disclaims any express or implied warranty, relating to its products including, but not limited to, the implied warranty of merchantability, fitness for a particular purpose, or infringement of any intellectual property right.

The products described in this document are not designed, intended, authorized or warranted for use as components in systems intended for surgical implant into the body, or in other applications intended to support or sustain life, or where malfunction of IXYS Integrated Circuits Division's product may result in direct physical harm, injury, or death to a person or severe property or environmental damage. IXYS Integrated Circuits Division reserves the right to discontinue or make changes to its products at any time without notice.

Specification: DS-IX2204-R02
 ©Copyright 2014, IXYS Integrated Circuits Division
 All rights reserved. Printed in USA.
 2/24/2014

X-ON Electronics

Largest Supplier of Electrical and Electronic Components

Click to view similar products for [Gate Drivers](#) category:

Click to view products by [IXYS](#) manufacturer:

Other Similar products are found below :

[89076GBEST](#) [00053P0231](#) [56956](#) [57.404.7355.5](#) [LT4936](#) [57.904.0755.0](#) [5882900001](#) [00600P0005](#) [00-9050-LRPP](#) [00-9090-RDPP](#)
[5951900000](#) [01-1003W-10/32-15](#) [0131700000](#) [00-2240](#) [LTP70N06](#) [LVP640](#) [5J0-1000LG-SIL](#) [LY1D-2-5S-AC120](#) [LY2-US-AC240](#) [LY3-](#)
[UA-DC24](#) [00576P0020](#) [00600P0010](#) [LZN4-UA-DC12](#) [LZNQ2M-US-DC5](#) [LZNQ2-US-DC12](#) [LZP40N10](#) [00-8196-RDPP](#) [00-8274-RDPP](#)
[00-8275-RDNP](#) [00-8722-RDPP](#) [00-8728-WHPP](#) [00-8869-RDPP](#) [00-9051-RDPP](#) [00-9091-LRPP](#) [00-9291-RDPP](#) [0207100000](#) [0207400000](#)
[01312](#) [0134220000](#) [60713816](#) [M15730061](#) [61161-90](#) [61278-0020](#) [6131-204-23149P](#) [6131-205-17149P](#) [6131-209-15149P](#) [6131-218-17149P](#)
[6131-220-21149P](#) [6131-260-2358P](#) [6131-265-11149P](#)