



### Features

- Under Voltage Lock-Out Protection (UVLO) with Hysteresis
- Desaturation Detection
- Miller Clamping
- Open Collector Isolated fault feedback
- “Soft” IGBT Turn-off
- Fault Reset by next LED turn-on (low to high) after fault mute period
- Available in 16-pin SOIC package

### Applications

- Isolated IGBT/Power MOSFET gate drive

### Approvals

- UL 1577 Certified Component
- CSA Certified Component: Certificate 70173160

### Description

The IX332B is an advanced 2.5A output current, optically isolated, IGBT gate driver that integrates  $V_{CE}$  desaturation detection, UVLO fault status feedback, and active Miller clamping.

The IX332B is constructed as a power optocoupler with  $4250V_{rms}$  isolation between the control input and power output stages. In addition, an optically isolated, open-collector feedback circuit relays FAULT status to the controller. Both optical isolation circuits employ highly efficient infrared LEDs.

Featuring soft IGBT turn-off, isolated fault feedback, under voltage lock-out with hysteresis, active Miller clamping, and  $V_{CE}$  desaturation detection, the IX332B offers engineers design flexibility and maximum circuit protection.

### Ordering Information

Part	Description
IX332B	16-Pin SOIC Package (50/Tube)
IX332BTR	16-Pin SOIC Package(1000/Reel)

### IX332B Block Diagram

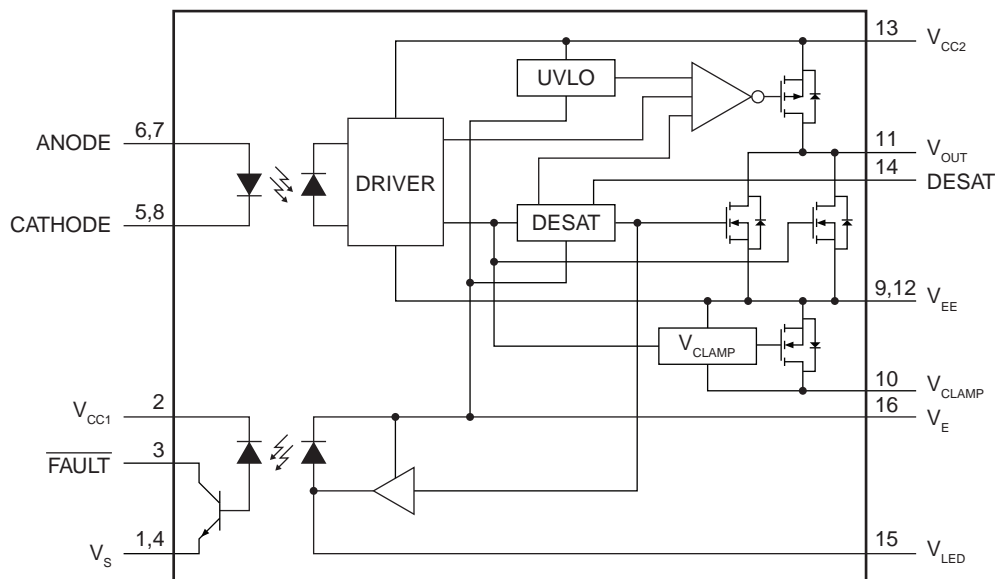

<b>1. Specifications</b> .....	<b>3</b>
1.1 Package Pinout .....	3
1.2 Pin Description .....	3
1.3 Absolute Maximum Ratings .....	4
1.4 Recommended Operating Conditions .....	4
1.5 Electrical Specifications (DC) .....	5
1.6 Switching Specifications (AC) .....	6
1.7 Isolation Characteristics .....	7
<b>2. Performance Data</b> .....	<b>8</b>
<b>3. Application Information</b> .....	<b>16</b>
3.1 Product Overview .....	16
3.2 Normal Operation and Application Circuit .....	16
3.3 Desat Protection, Fault Output Condition and Fault Reset .....	17
3.4 DESAT Pin Protection & D <sub>DESAT</sub> Diode Selection .....	18
3.5 Soft IGBT Turn-Off .....	18
3.6 Under-Voltage Lockout (UVLO) .....	18
3.7 Active Miller Clamp Function .....	18
3.8 Increasing the Output Drive Current for Higher Power Applications .....	19
<b>4. Manufacturing Information</b> .....	<b>20</b>
4.1 Moisture Sensitivity .....	20
4.2 ESD Sensitivity .....	20
4.3 Soldering Profile .....	20
4.4 Board Wash .....	20
4.5 Package Mechanical Dimensions .....	21
4.5.1 IX332B 16-Pin SOIC .....	21
4.5.2 IX332BTR Tape & Reel .....	21

## 1. Specifications

### 1.1 Package Pinout

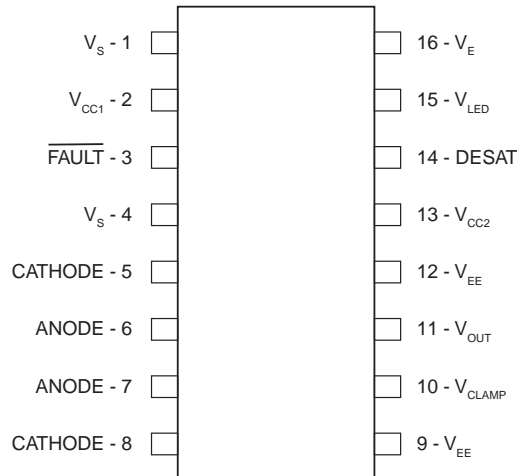

### 1.2 Pin Description

Pin#	Name	Description
1	$V_S$	Fault Channel Ground
2	$V_{CC1}$	Positive Fault Channel supply voltage. (3.3 V to 5.5 V)
3	$\overline{FAULT}$	Fault output. $\overline{FAULT}$ changes from a high impedance state to a logic low output due to the voltage on the DESAT pin exceeding an internal reference voltage. $\overline{FAULT}$ output is an open collector output.
4	$V_S$	Fault Channel Ground
5	CATHODE	Cathode
6	ANODE	Anode
7	ANODE	Anode
8	CATHODE	Cathode
9	$V_{EE}$	Output supply voltage return
10	$V_{CLAMP}$	Miller clamp
11	$V_{OUT}$	Gate drive voltage output
12	$V_{EE}$	Output supply voltage return
13	$V_{CC2}$	Positive output supply voltage
14	DESAT	Desaturation voltage input. When the voltage on DESAT exceeds an internal reference voltage of 6.5V while the IGBT is on, $\overline{FAULT}$ output is changed from a high impedance state to a logic low state.
15	$V_{LED}$	LED anode. This pin must be left unconnected for guaranteed data sheet performance. (For optical coupling testing only)
16	$V_E$	Common (IGBT emitter) output supply voltage.

### 1.3 Absolute Maximum Ratings

Parameter	Symbol	Min	Max	Units	Note
Storage Temperature	$T_S$	-	125	°C	-
Operating Temperature	$T_A$	- 40	105	°C	2
Output IC Junction Temperature	$T_J$	-	125	°C	2
Average Input Current	$I_{F(AVG)}$	-	20	mA	1
Peak Transient Input Current, (<1 $\mu$ s pulse width, 300pps)	$I_{F(TRAN)}$	-	1	A	-
Reverse Input Voltage	$V_R$	-	5	V	-
“High” Peak Output Current	$I_{OH(PEAK)}$	-	2.5	A	3
“Low” Peak Output Current	$I_{OL(PEAK)}$	-	2.5	A	3
Positive Input Supply Voltage	$V_{CC1}$	- 0.5	7	V	-
$\overline{FAULT}$ Output Current	$I_{FAULT}$	-	8	mA	-
$\overline{FAULT}$ Pin Voltage	$V_{FAULT}$	- 0.5	$V_{CC1}$	V	-
Total Output Supply Voltage	$(V_{CC2} - V_{EE})$	- 0.5	35	V	-
Negative Output Supply Voltage	$(V_E - V_{EE})$	- 0.5	15	V	-
Positive Output Supply Voltage	$(V_{CC2} - V_E)$	- 0.5	$35 - (V_E - V_{EE})$	V	-
Gate Drive Output Voltage	$V_{O(PEAK)}$	- 0.5	$V_{CC2}$	V	-
Peak Clamping Sinking Current	$I_{Clamp}$	-	1.7	A	-
Miller Clamping Pin Voltage	$V_{Clamp}$	- 0.5	$V_{CC2}$	V	-
DESAT Voltage	$V_{DESAT}$	$V_E$	$V_E + 10$	V	-
Input Power Dissipation	$P_I$	50	-	mW	-
Output Power Dissipation	$P_O$	-	600	mW	2
Isolation Voltage	$V_{ISO}$	4250	-	$V_{rms}$	17,18

### 1.4 Recommended Operating Conditions

Parameter	Symbol	Min	Max	Units	Note
Operating Temperature	$T_A$	- 40	105	°C	2
Total Output Supply Voltage	$(V_{CC2} - V_{EE})$	15	30	V	-
Negative Output Supply Voltage	$(V_E - V_{EE})$	0	15	V	4
Positive Output Supply Voltage	$(V_{CC2} - V_{EE})$	15	$30 (V_E - V_{EE})$	V	-
Input Current (ON)	$I_{F(ON)}$	8	12	mA	-
Input Voltage (OFF)	$V_{F(OFF)}$	- 3.6	0.8	V	-

**1.5 Electrical Specifications (DC)**

Unless otherwise noted, all typical values at  $T_A = 25^\circ\text{C}$ ,  $V_{CC2} - V_{EE} = 30\text{V}$ ,  $V_E - V_{EE} = 0\text{V}$ ; all Minimum/Maximum specifications are at Recommended Operating Conditions. Positive Supply Voltage used.

Parameter	Conditions	Symbol	Min	Typ	Max	Units	Fig.	Note
FAULT Logic Low Output Voltage	$I_{\text{FAULT}} = 1.1 \text{ mA}$ , $V_{\text{CC1}} = 5.5\text{V}$	$V_{\text{FAULTL}}$	-	0.1	0.4	V	-	-
	$I_{\text{FAULT}} = 1.1 \text{ mA}$ , $V_{\text{CC1}} = 3.3\text{V}$		-	0.1	0.4		-	-
FAULT Logic High Output Current	$V_{\text{CC1}} = 5.5\text{V}$	$I_{\text{FAULTH}}$	-	0.037	0.5	$\mu\text{A}$	-	-
	$V_{\text{CC1}} = 3.3\text{V}$		-	0.016	0.3		-	-
High Level Output Current	$V_O = V_{\text{CC2}} - 4\text{V}$	$I_{\text{OH}}$	-0.5	-	-	A	2,6,22	5
	$V_O = V_{\text{CC2}} - 15\text{V}$		-2	-	-			3
Low Level Output Current	$V_O = V_{\text{EE}} + 2.5\text{V}$	$I_{\text{OL}}$	0.5	-	-	A	3,7,23	5
	$V_O = V_{\text{EE}} + 15\text{V}$		2	-	-			3
Low Level Output Current During Fault Condition	$V_{\text{OUT}} - V_{\text{EE}} = 14\text{V}$	$I_{\text{OLF}}$	90	121	230	mA	-	-
High Level Output Voltage	$I_O = 100\text{mA}$	$V_{\text{OH}}$	$V_{\text{CC}} - 0.5$	-	-	V	4,25	-
Low Level Output Voltage	$I_O = 100\text{mA}$	$V_{\text{OL}}$	-	0.166	0.5	V	5,26	-
Clamp Pin Threshold Voltage	-	$V_{\text{tClamp}}$	-	3.1	-	V	-	-
Clamp Low Level Sinking Current	$V_O = V_{\text{EE}} + 2.5\text{V}$	$I_{\text{CL}}$	0.4	-	-	A	8	-
High Level Supply Current	$I_O = 0\text{mA}$	$I_{\text{CC2H}}$	-	3.8	5	mA	10,11,27,28	-
Low Level Supply Current	$I_O = 0\text{mA}$	$I_{\text{CC2L}}$	-	2.75	5	mA		-
Blanking Capacitor Charging Current	$V_{\text{DESAT}} = 2\text{V}$	$I_{\text{CHG}}$	-0.13	0.247	-0.33	mA	12,29	6
Blanking Capacitor Discharge Current	$V_{\text{DESAT}} = 7\text{V}$	$I_{\text{DISCHG}}$	10	29	-	mA	30	-
DESAT Threshold	$V_{\text{CC2}} - V_E > V_{\text{UVLO-}}$	$V_{\text{DESAT}}$	6	6.5	7.5	V	13	-
UVLO Threshold	$V_O > 5\text{V}$	$V_{\text{UVLO+}}$	10.5	11.8	12.5	V	-	7
	$V_O < 5\text{V}$	$V_{\text{UVLO-}}$	9.2	10.4	11.1		-	8
UVLO Hysteresis	-	$(V_{\text{UVLO+}}) - (V_{\text{UVLO-}})$	0.4	1.4	-	V	-	-
Threshold Input Current Low to High	$I_O = 0\text{mA}$ , $V_O > 5\text{V}$	$I_{\text{FLH}}$	-	0.9	4	mA	-	-
Threshold Input Voltage High to Low		$V_{\text{FHL}}$	0.8	-	-	V	-	-
Input Forward Voltage	$I_F = 10\text{mA}$	$V_F$	1	1.4	1.75	V	-	-
Temperature Coefficient of Input Forward Voltage	-	$\Delta V_F / \Delta T_A$	-	1.3	-	mV/°C	-	-
Input Reverse Breakdown Voltage	$I_R = 10\mu\text{A}$	$B_{\text{VR}}$	5	-	-	V	-	-
Input Capacitance	$f = 1\text{MHz}$ , $V_F = 0\text{V}$	$C_{\text{IN}}$	-	26	-	pF	-	-

**1.6 Switching Specifications (AC)**

Unless otherwise noted, all typical values at  $T_A = 25^\circ\text{C}$ ,  $V_{CC2} - V_{EE} = 30\text{V}$ ,  $V_E - V_{EE} = 0\text{V}$ ; all Minimum/Maximum specifications are at Recommended Operating Conditions. Only Positive Supply Voltage used.

Parameter	Conditions	Symbol	Min	Typ	Max	Units	Fig.	Note
Propagation Delay Time to High Output Level	$R_g = 10\Omega$ , $C_g = 10\text{nF}$ , $f = 10\text{kHz}$ , Duty Cycle = 50%, $I_F = 10\text{mA}$ , $V_{CC2} = 30\text{V}$	$t_{PLH}$	70	109	220	ns	1,14,15, 16,17,31	10
Propagation Delay Time to Low Output Level		$t_{PHL}$	70	112	220		1,14,15, 16,17,31	-
Pulse Width Distortion		PWD	-100	3	100		-	9,12
Propagation Delay Difference Between Any Two Parts or Channels		$(t_{PHL} - t_{PLH})$ PDD	-150	-	150		-	11,12
Rise Time		$t_R$	-	13	-		-	-
Fall Time		$t_F$	-	10	-		-	-
DESAT Sense to 90% VO Delay	$C_{DESAT} = 100\text{pF}$ , $R_g = 10\Omega$ , $C_g = 10\text{nF}$ , $V_{CC2} = 30\text{V}$	$t_{DESAT(90\%)}$	-	0.2	0.5	$\mu\text{s}$	18,32,38	14
DESAT Sense to 10% VO Delay	$C_{DESAT} = 100\text{pF}$ , $R_g = 10\Omega$ , $C_g = 10\text{nF}$ , $V_{CC2} = 30\text{V}$	$t_{DESAT(10\%)}$	-	1.7	3	$\mu\text{s}$	19,20,21, 38	-
DESAT Sense to Low Level FAULT Signal Delay	$C_{DESAT} = 100\text{pF}$ , $R_F = 2.1\text{k}\Omega$ , $C_F = \text{Open}$ , $R_g = 10\Omega$ , $C_g = 10\text{nF}$ , $V_{CC2} = 30\text{V}$	$t_{DESAT(FAULT)}$	-	0.120	0.5	$\mu\text{s}$	32,38	13
DESAT Sense to DESAT Low Propagation Delay	$C_{DESAT} = 100\text{pF}$ , $R_F = 2.1\text{k}\Omega$ , $R_g = 10\Omega$ , $C_g = 10\text{nF}$ , $V_{CC2} = 30\text{V}$	$t_{DESAT(LOW)}$	-	0.1	-	$\mu\text{s}$	32,38	14
DESAT Input Mute		$t_{DESAT(MUTE)}$	5	-	-	$\mu\text{s}$	38	-
RESET to High Level FAULT Signal Delay	$C_{DESAT} = 100\text{pF}$ , $R_F = 2.1\text{k}\Omega$ , $R_g = 10\Omega$ , $C_g = 10\text{nF}$ , $V_{CC1} = 5.5\text{V}$ , $V_{CC2} = 30\text{V}$	$t_{RESET(FAULT)}$	-	1	2	$\mu\text{s}$	-	-
	$C_{DESAT} = 100\text{pF}$ , $R_F = 2.1\text{k}\Omega$ , $R_g = 10\Omega$ , $C_g = 10\text{nF}$ , $V_{CC1} = 3.3\text{V}$ , $V_{CC2} = 30\text{V}$		0.8	1.1	2.5		-	-
Output High Level Common Mode Transient Immunity	$T_A = 25^\circ\text{C}$ , $I_F = 10\text{mA}$ $V_{CM} = 1500\text{V}$ , $V_{CC2} = 30\text{V}$ , $R_F = 2.1\text{k}\Omega$ , $C_F = 15\text{pF}$	$ CM_H $	25	-	-	kV/ $\mu\text{s}$	33,34,35, 36	15
	$T_A = 25^\circ\text{C}$ , $I_F = 10\text{mA}$ $V_{CM} = 1500\text{V}$ , $V_{CC2} = 30\text{V}$ , $R_F = 2.1\text{k}\Omega$ , $C_F = 200\text{pF}$		50	-	-			15,19
Output Low Level Common Mode Transient Immunity	$T_A = 25^\circ\text{C}$ , $V_F = 0\text{V}$ $V_{CM} = 1500\text{V}$ , $V_{CC2} = 30\text{V}$ , $R_F = 2.1\text{k}\Omega$ , $C_F = 15\text{pF}$	$ CM_L $	25	-	-	kV/ $\mu\text{s}$	33,34,35, 36	16
	$T_A = 25^\circ\text{C}$ , $V_F = 0\text{V}$ $V_{CM} = 1500\text{V}$ , $V_{CC2} = 30\text{V}$ , $R_F = 2.1\text{k}\Omega$ , $C_F = 200\text{pF}$		50	-	-			

**1.7 Isolation Characteristics**

Parameter	Conditions	Symbol	Min	Units	Fig.	Note
Insulation Resistance	$V_{IO} = 500\text{ V}$	$R_{IO}$	$10^9$	$\Omega$	-	18
Input-Output Momentary Withstand Voltage	$RH < 50\%$ , $t = 1\text{ min}$ , $T_A = 25^\circ\text{C}$	$V_{ISO}$	4250	$V_{rms}$	-	17,18
Capacitance (Input-Output), Typical	$f = 1\text{ MHz}$	$C_{IO}$	0.5	pF	-	-

**Notes:**

- Derate linearly above 70°C free air temperature at a rate of 0.3mA/°C.
- Derate linearly above 25°C free air temperature at a rate of 6.2mW/°C.
- Maximum pulse width = 10µs. This value is intended to allow for component tolerances for designs with IO peak minimum = 2A. Derate linearly from 3A at +25°C to 2.5A at +105°C. This compensates for increased  $I_{OPEAK}$  due to changes in  $V_{OL}$  over temperature.
- This supply is optional. Required only when negative gate drive is implemented.
- Maximum pulse width = 50µs.
- See the DESAT fault detection blanking time section in the applications notes at the end of this data sheet for further details.
- This is the “increasing” (i.e. turn-on, or “positive going,” direction) of  $V_{CC2} - V_E$
- This is the “decreasing” (i.e. turn-off, or “negative going,” direction) of  $V_{CC2} - V_E$
- Pulse Width Distortion (PWD) is defined as  $|t_{PHL} - t_{PLH}|$  for any given unit.
- As measured from  $I_F$  to  $V_O$ .
- The difference between  $t_{PHL}$  and  $t_{PLH}$  between any two IX332B parts under the same test conditions.
- As measured from ANODE, CATHODE of LED to  $V_{OUT}$
- This is the amount of time from when the DESAT threshold is exceeded, until the FAULT output goes low.
- This is the amount of time the DESAT threshold must be exceeded before  $V_{OUT}$  begins to go low, and the FAULT output to go low. This is supply voltage dependent.
- Common mode transient immunity in the high state is the maximum tolerable  $dV_{CM}/dt$  of the common mode pulse,  $V_{CM}$ , to assure that the output will remain in the high state (i.e.,  $V_O > 15V$  or  $FAULT > 2V$ ).
- Common mode transient immunity in the low state is the maximum tolerable  $dV_{CM}/dt$  of the common mode pulse,  $V_{CM}$ , to assure that the output will remain in a low state (i.e.,  $V_O < 1V$  or  $FAULT < 0.8V$ ).
- In accordance with UL 1577, each optocoupler is proof tested by applying an insulation test voltage: 5100 $V_{rms}$  for one second.
- This is a two-terminal measurement: pins 1-8 are shorted together and pins 9-16 are shorted together.
- Split resistors network with a ratio of 1:1 is needed at input LED1. See **Figure 36**.

2. Performance Data

Figure 1.

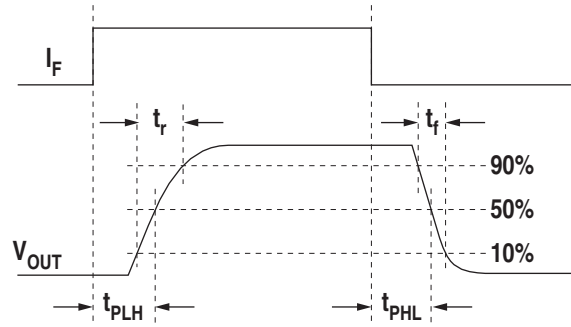

Figure 2.

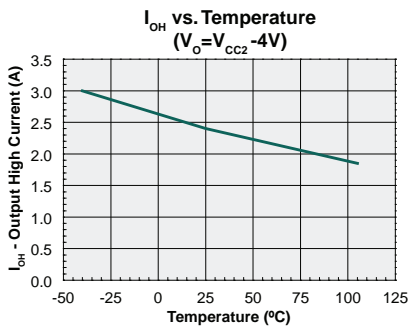

Figure 4.

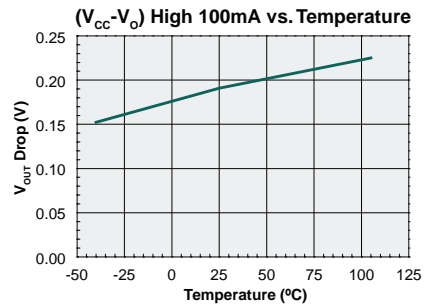

Figure 3.

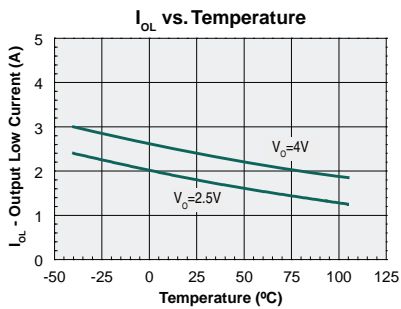

Figure 5.

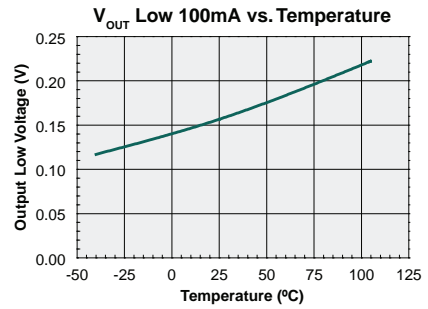



Figure 6.

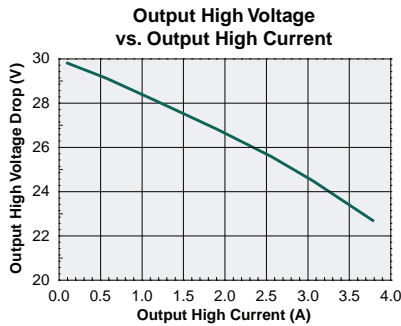

Figure 10.

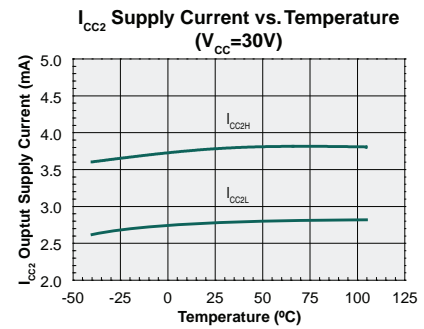

Figure 7.

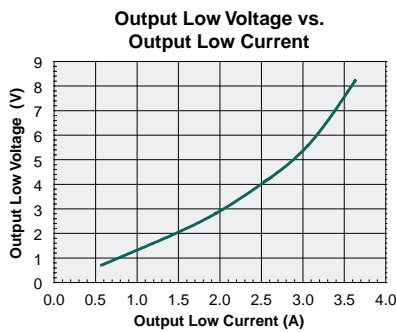

Figure 11.

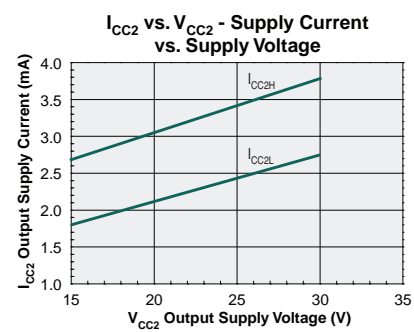

Figure 8.

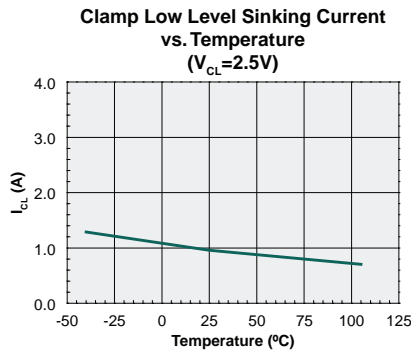

Figure 12.

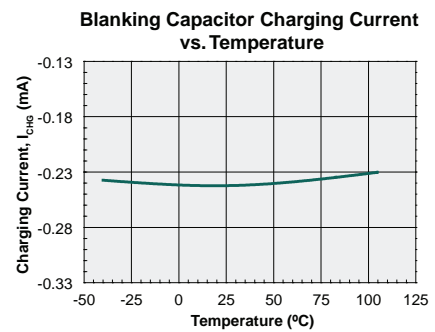

Figure 9.

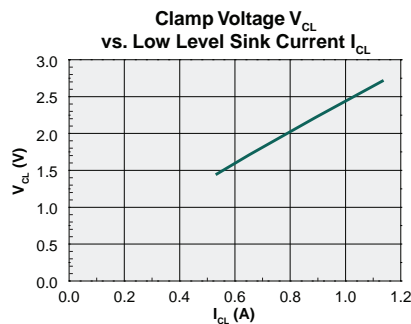

Figure 13.

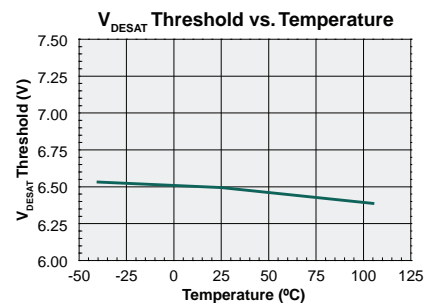

Figure 14.

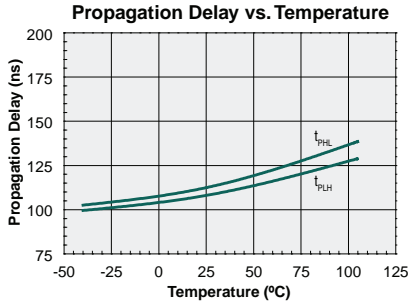

Figure 18.

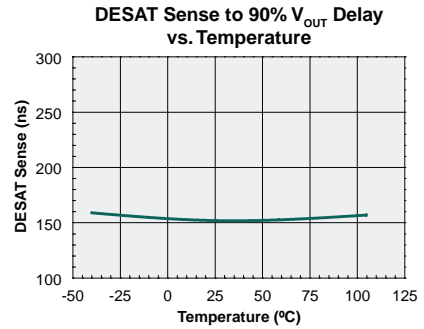

Figure 15.

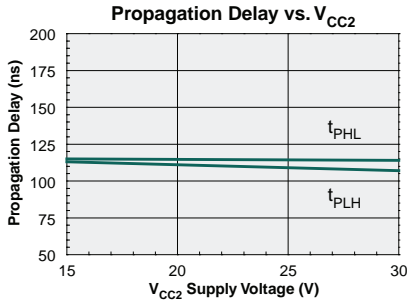

Figure 19.

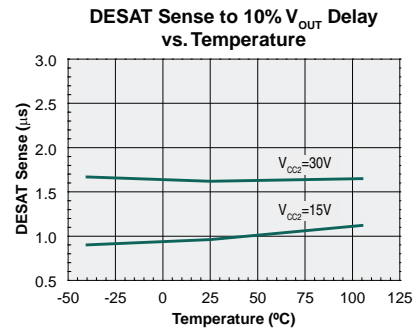

Figure 16.

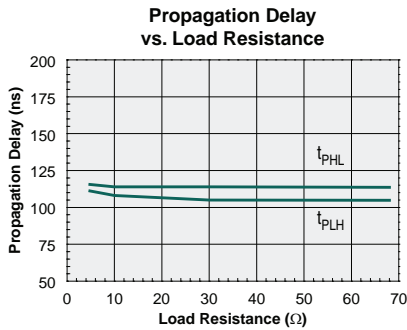

Figure 20.

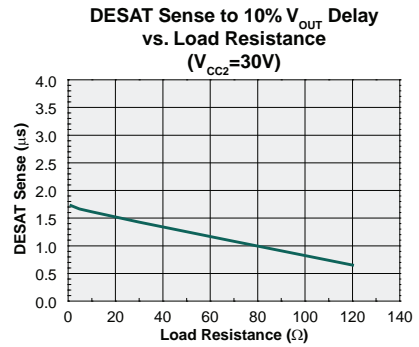

Figure 17.

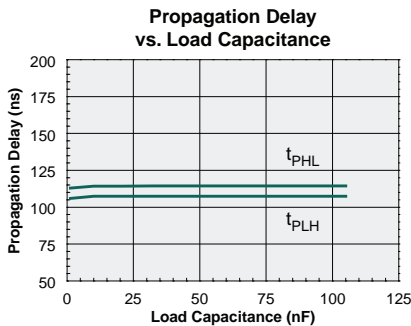

Figure 21.

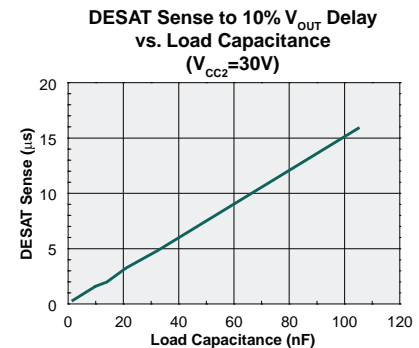

Figure 22.  $I_{OH}$  Pulsed &  $V_{OH}$  vs.  $I_{OH}$  Test Circuit

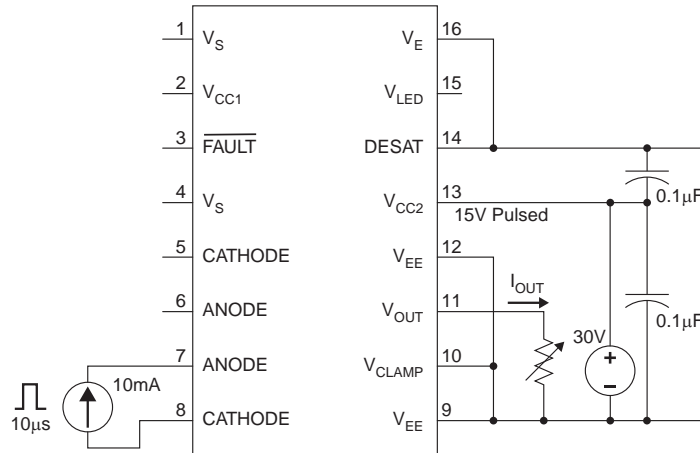

Figure 23.  $I_{OL}$  Pulsed Test Circuit

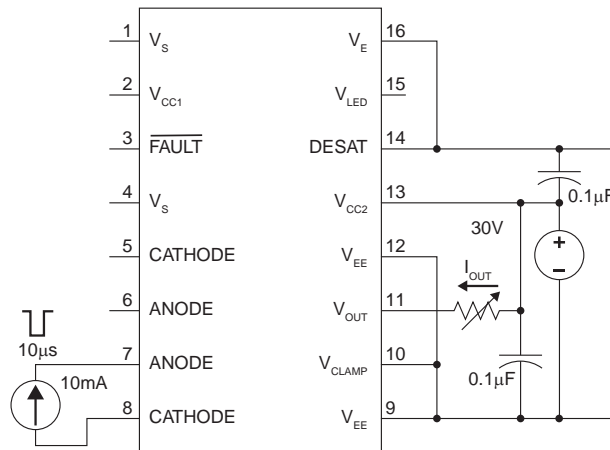

Figure 24.  $V_{CL}$  vs.  $I_{CL}$  Test Circuit

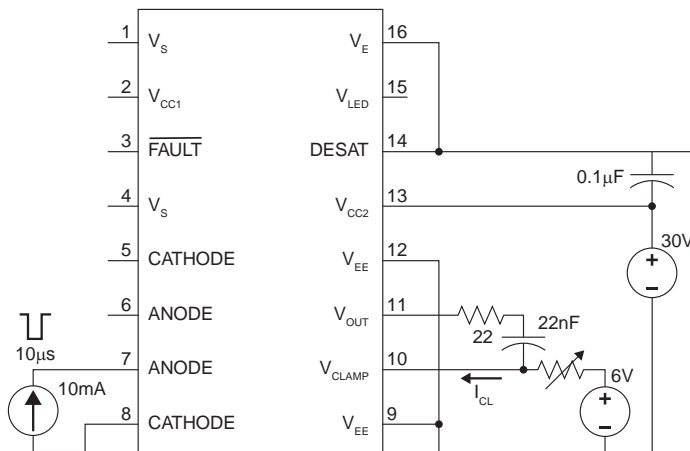

Figure 25.  $V_{OH}$  Test Circuit

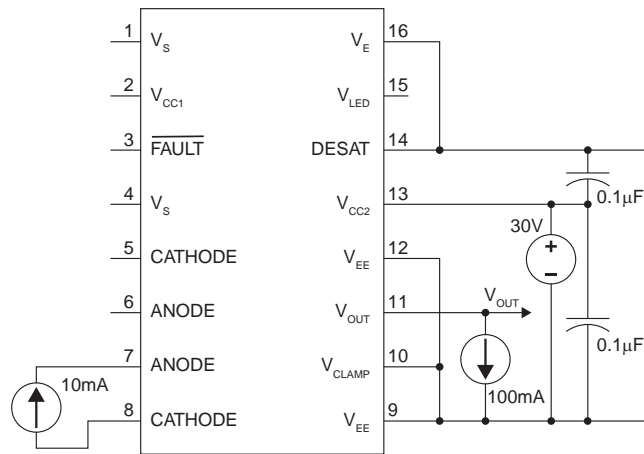

Figure 26.  $V_{OL}$  Test Circuit

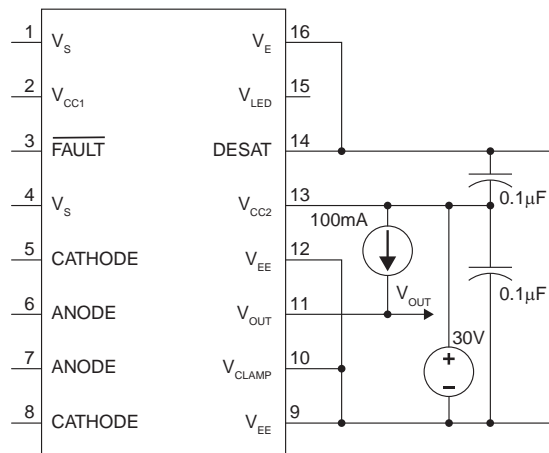

Figure 27.  $I_{CC2H}$  Test Circuit

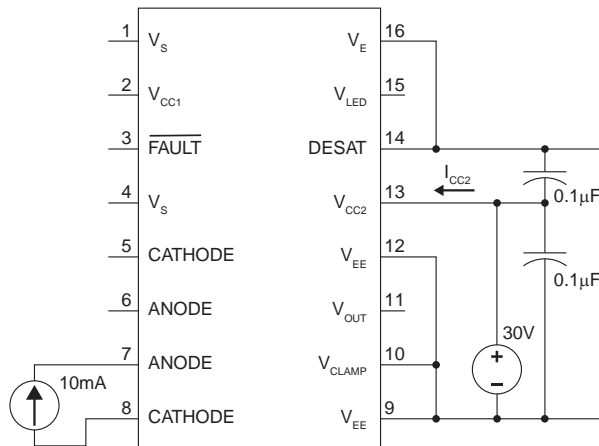

Figure 28.  $I_{CC2L}$  Test Circuit

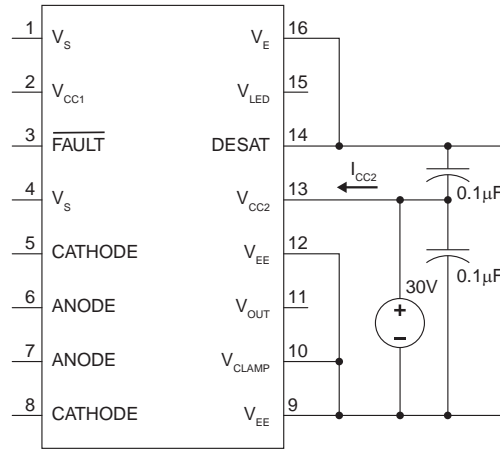

Figure 29.  $I_{CHG}$  Pulsed Test Circuit

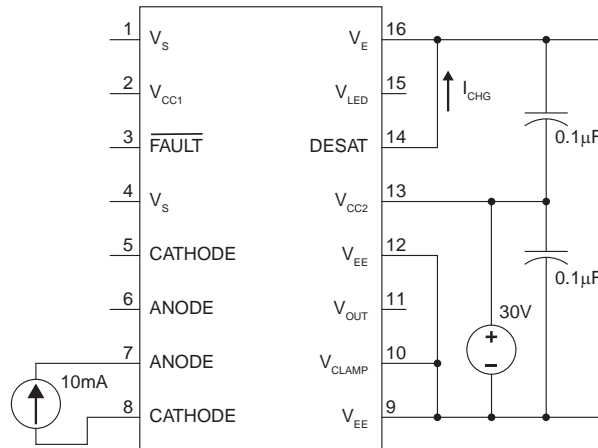

Figure 30.  $I_{DISCHG}$  Test Circuit

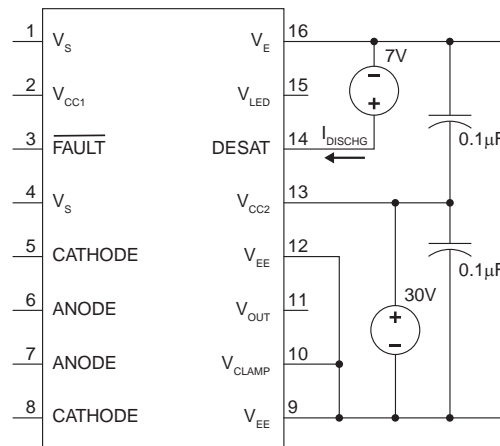

Figure 31.  $t_{PLH}$ ,  $t_{PHL}$ ,  $t_F$ ,  $t_R$  Test Circuit

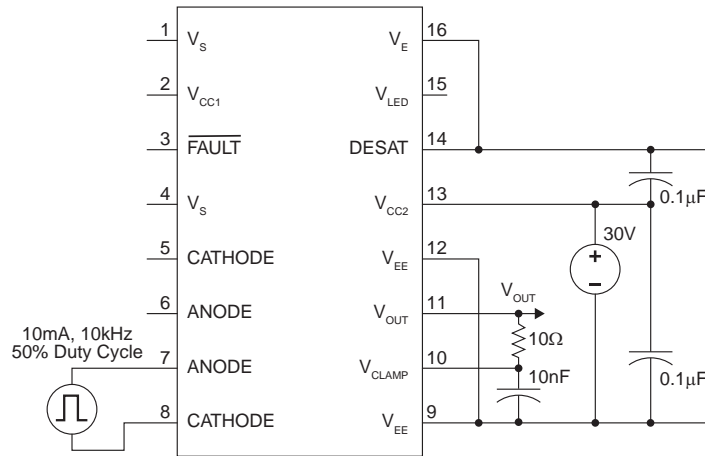

Figure 32.  $t_{DESAT}$  Fault Test Circuit

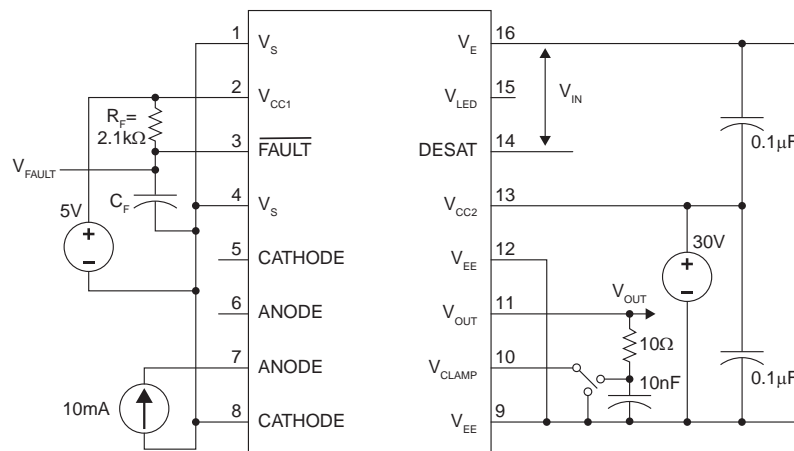
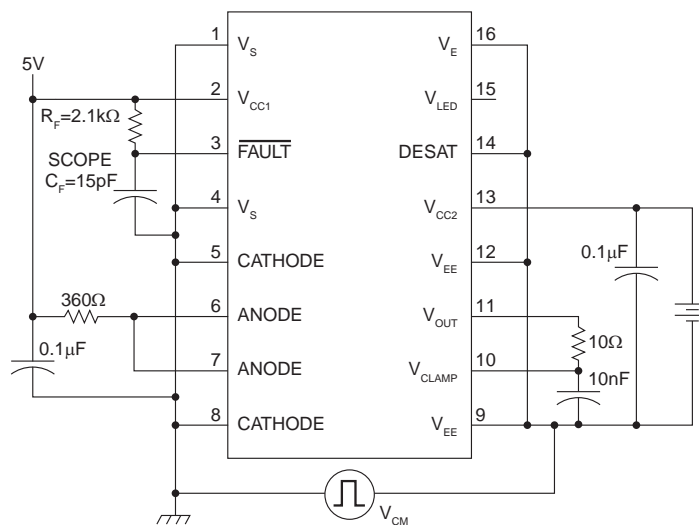
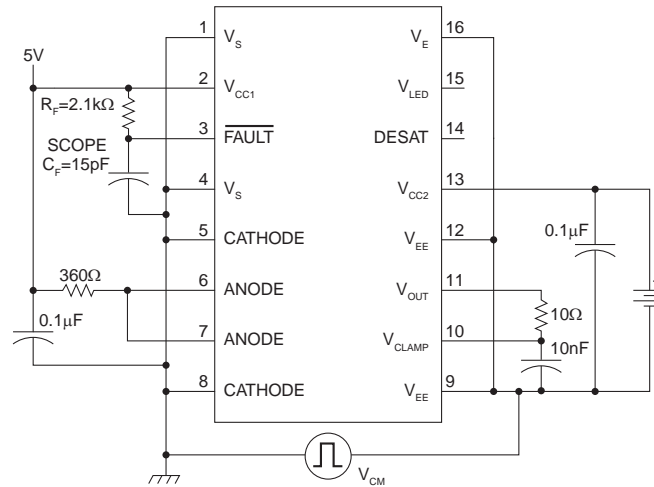

Figure 33. CMR Test Circuit LED2 Off



**Figure 34. CMR Test Circuit LED2 On**



**Figure 35. Driver CMR Test Circuit LED1 Off**

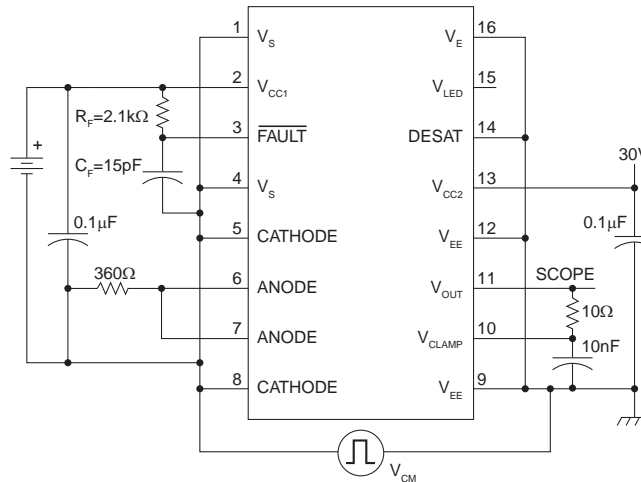

**Figure 36. Driver CMR Test Circuit LED1 On**

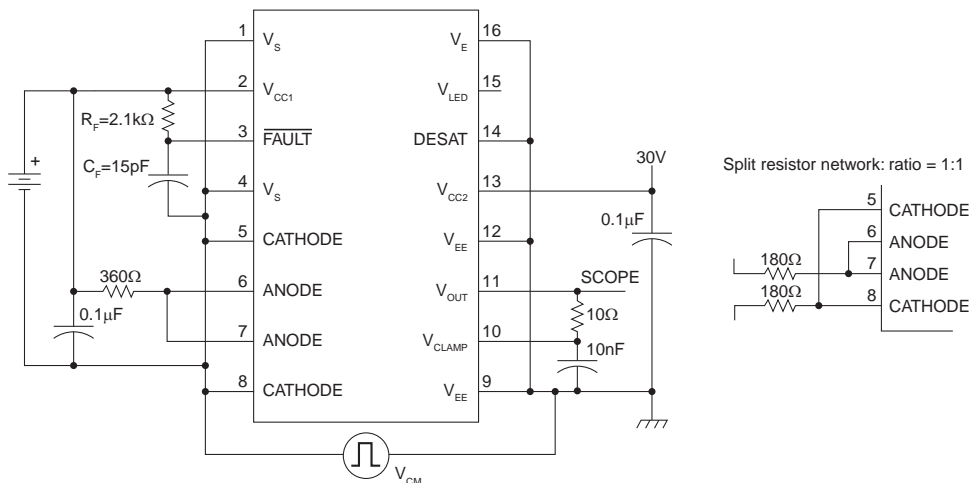

### 3. Application Information

#### 3.1 Product Overview

The IX332B is a high speed, optically isolated, 2.5A output current gate driver capable of driving power IGBTs and MOSFETs with voltage ratings up to 1200V. It is very well suited for various industrial motor control inverter applications and other power supply systems where isolation and power switch protection is of critical importance.

The driver includes many integrated features such as an active Miller clamp, which simplifies some designs by eliminating the need for negative gate drive and also allows for an inexpensive bootstrap supply for a high side driver. The desaturation detection circuit protects the driven IGBT from short circuits, and provides an isolated optical feedback channel in case a fault condition has occurred. In addition, there is an under voltage lockout (UVLO) that provides protection in case insufficient voltage is present at the gate drive.

This integrated gate driver consists of two isolated channels activated by light emitting diodes which are optically coupled to an integrated driver circuit. This optical circuit arrangement achieves high input to output isolation voltage of 4250Vrms while maintaining high common mode noise immunity. The IX332B is housed in compact 16- Pin SOIC package.

#### 3.2 Normal Operation and Application Circuit

The circuit in **Figure 37** shows the minimum circuit configuration for the IX332B.

Driving the LED turns on the Gate drive voltage  $V_{OUT}$  via the internal isolated gate drive circuitry and PMOS transistor. When LED is turned on,  $V_{OUT}$  approaches  $V_{CC2}$  and provides sufficient gate voltage for the external IGBT device assuming:

$$V_{GEmax} > (V_{CC2} - V_{EE}) > V_{GETH}$$

where  $V_{GEmax}$  is the IGBT maximum specified  $V_{GE}$  voltage and  $V_{GETH}$  is the minimum  $V_{GE}$  threshold of the IGBT device. The UVLO function on the IX332B will prevent the IGBT from turning on if there is not sufficient voltage at the gate as described in **Section 3.6**.

To turn on the device, a nominal current of 10mA is driven through the LED by a standard CMOS gate, transistor or microprocessor I/O line. **Figure 37** shows a microprocessor I/O capable of sinking the required

10mA to activate the LED and the output.  $R_{LED}$  is the LED limiting resistor where the value is determined by:

$$R_{LED} = \frac{V_{CC1} - V_F}{10mA}$$

where  $V_F$  is the maximum LED forward voltage published on the data sheet. For the example circuit in **Figure 37** for a 3.3V system we have:

$$R_{LED} = \frac{3.3V - 1.5V}{10mA} = 180\Omega$$

which is a standard value.

Referring to the figure,  $D_{DESAT}$  is a fast recovery diode described in **Section 3.4**. Resistor  $R_D$  and capacitor  $C_D$  form a time constant for the DESAT blanking interval. Also,  $R_D$  limits current to the DESAT pin as protection from excessive current damaging the IC.

Resistor  $R_G$  limits gate charge current and controls IGBT rise and fall times. The test circuits use a value of 15 $\Omega$ . The IGBT gate drive components are discussed in more detail in the applications section. The connection from the IX332B through  $R_G$  to the gate of the IGBT should be as low inductance as possible to prevent excessive ringing.

The  $V_{CLAMP}$  pin is the Miller clamping circuit that connects to the IGBT gate to safely turn off the IGBT in single supply applications.

The two 0.1 $\mu$ F capacitors are used for decoupling switching transients and should be placed close to the respective pins in the layout of the PCB.

The  $\overline{FAULT}$  pin is an open collector output indicating a DESAT. This pin requires an adequately sized pull-up resistor  $R_P$  to  $V_{CC1}$  to be functional. Additionally,  $C_F$  can be installed as a filter capacitor for potential high voltage transients that can couple through the parasitic capacitance of the IX332B or PCB capacitance.



Figure 37. Typical Application Circuit

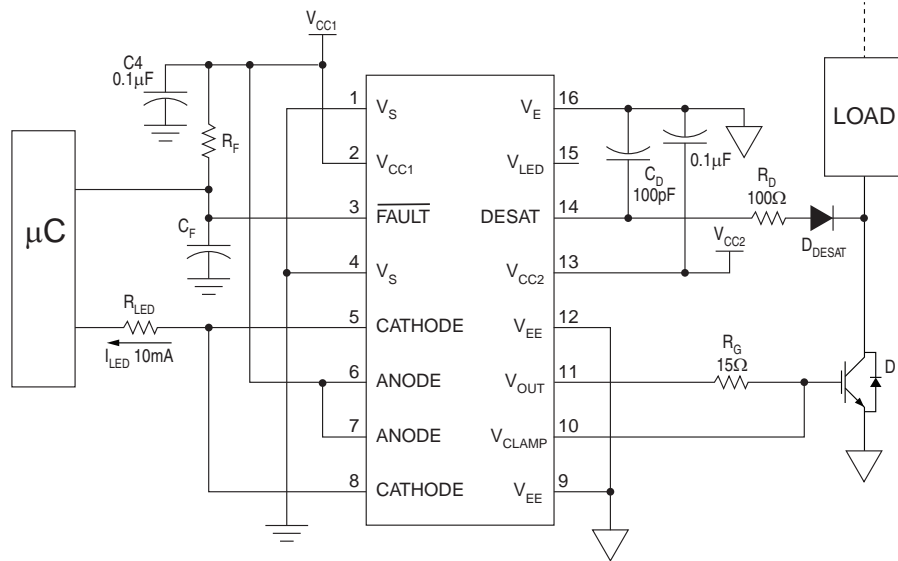

### 3.3 Desat Protection, Fault Output Condition and Fault Reset

The DESAT protection circuit monitors collector-emitter voltage of the IGBT, and triggers a shutdown when the detector reaches a predetermined threshold voltage, typically 6.5V. The output,  $V_{OUT}$ , is slowly turned low in order to prevent large di/dt generated voltages. The fault event activates the internal feedback channel that signals logic low to the microcontroller.

In order to make DESAT detection work during normal operation and prevent false triggering, a blanking time is implemented. The blanking time disables the detection circuit for a short period of time to enable the

IGBT to turn on and collector voltage to return to below the detection threshold.

Blanking time is controlled by the internal DESAT charge current,  $I_{CHG}$ , the  $V_{DESAT}$  voltage threshold, and the external DESAT capacitor. The blanking time can be calculated with this formula:

$$t_{BLANK} = \frac{C_{BLANK} \cdot V_{DESAT}}{I_{CHG}}$$

The nominal blanking time can be calculated using an initial blanking capacitor value of 100pF. The capacitance value can be adjusted, but smaller values are not recommended.

$$t_{BLANK} = \frac{100pF \cdot 6.5V}{240\mu A} = 2.7\mu s$$

Figure 38. Fault Reset

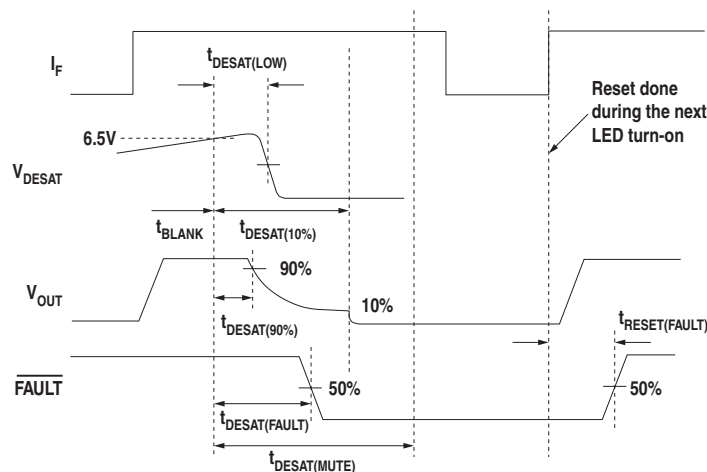

The fault output pin is an open collector output and requires a pullup resistor,  $R_F$ , to provide a high level signal. In addition, the  $\overline{\text{FAULT}}$  output can be OR-ed with additional external protection monitoring circuits. An external capacitor,  $C_F$ , on the  $\overline{\text{FAULT}}$  pin for high common mode rejection, CMR, is optional and not required because the IX332B will pass this test without the capacitor.

### 3.4 DESAT Pin Protection & $D_{\text{DESAT}}$ Diode Selection

Fast recovery, freewheeling diodes across power IGBTs are exposed to very large instantaneous voltage transients, which can be present on the DESAT pin. In order to limit these currents to levels that will not cause damage to the IC, a resistor,  $100\Omega$  to  $1k\Omega$ , should be placed in series with the diode.

The  $D_{\text{DESAT}}$  diode should be a fast recovery type with  $t_{\text{rr}}$  below  $75\text{nS}$  and a breakdown voltage rating of  $600\text{V}$  to  $1200\text{V}$ , depending on the application. The ES1J-600V diode, or equivalent, would be sufficient.

Figure 39. DESAT Pin Protection

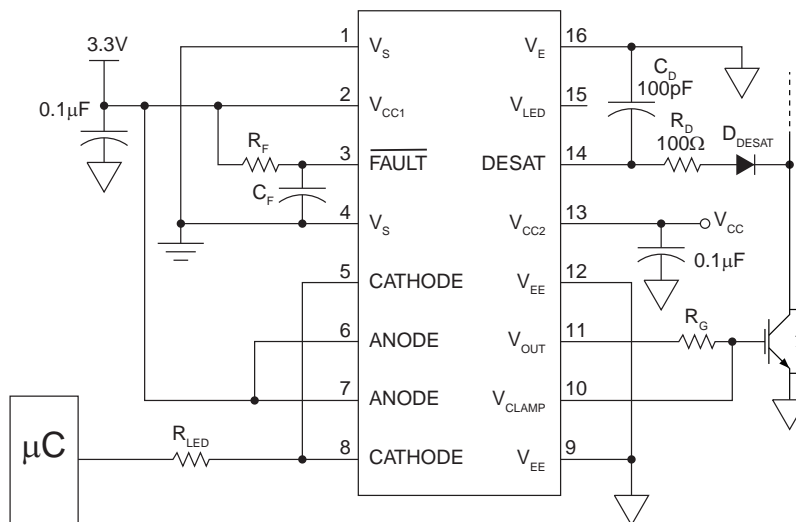

### 3.5 Soft IGBT Turn-Off

This feature ensures safe IGBT shutdown under fault conditions. The gate driver's  $V_{\text{OUT}}$  turns off the IGBT in a controlled manner that protects the output from developing large voltage spikes due to parasitic lead inductance, which could damage the IGBT.

### 3.6 Under-Voltage Lockout (UVLO)

In order to ensure proper power stage switching, the IX332B includes an under voltage lock out circuit, UVLO, which prevents the IGBT from turning on when insufficient voltage is present on the gate. The output voltage,  $V_{\text{OUT}}$ , remains low as long as the supply voltage,  $V_{\text{CC}} - V_{\text{EE}}$ , is less than  $V_{\text{UVLO+}}$  during power up. If the supply voltage falls below  $V_{\text{UVLO-}}$ , then  $V_{\text{OUT}}$  goes low.

### 3.7 Active Miller Clamp Function

The integrated active Miller clamp circuit enables the controlled sinking of current to ground during high  $dV/dT$  turn off transitions. An internal NMOS transistor clamp eliminates the need for the negative supply voltage that is commonly required to safely turn off a power IGBT. When turn-off is initiated, the gate voltage is monitored. The voltage clamp circuit is activated when the gate voltage  $V_{\text{OL}} = 2.5\text{V}$  (typical) relative to  $V_{\text{EE}}$ , and while Miller current is approximately  $1100\text{mA}$ . During the IGBT turn on cycle,  $V_{\text{CLAMP}}$  is disabled.

### 3.8 Increasing the Output Drive Current for Higher Power Applications

Where larger gate drive current is desired or the design calls for implementation of two modules in parallel, an output booster stage may be implemented by including a discrete NPN/PNP totem-pole configuration. The booster transistors should be fast

switching and have sufficient current gain to deliver the desired peak output current. See **Figure 40**.

In addition, an external V-clamp function can be implemented using a PNP transistor and R3 resistor to control the secondary discharge path for higher power applications. See **Figure 41**.

**Figure 40. Application Circuit 1**

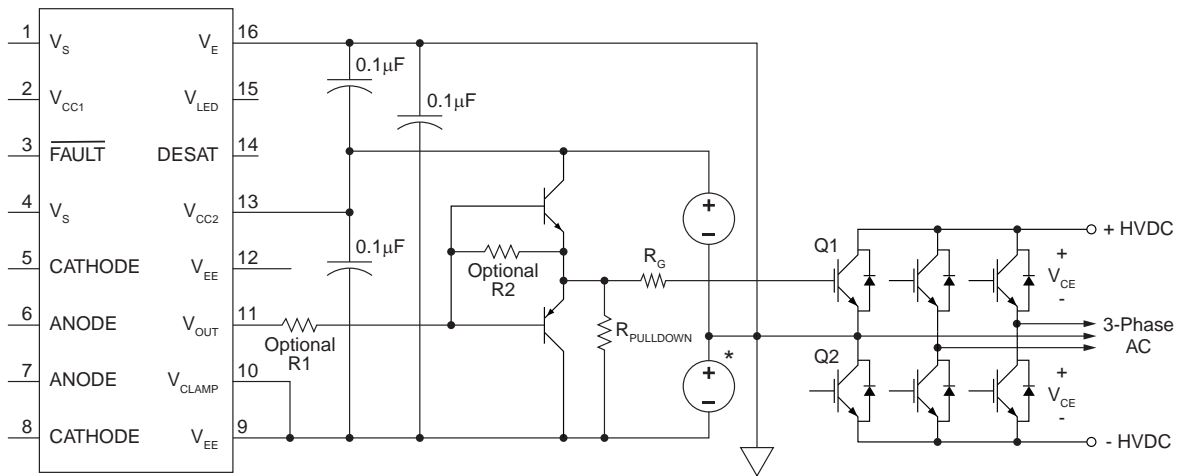

IGBT drive with negative gate drive, external booster and desaturation detection ( $V_{CLAMP}$  should be connected to  $V_{EE}$  when it is not used)  $V_{CLAMP}$  is used as secondary gate discharge path. \* indicates component required for negative gate drive topology.

**Figure 41. Application Circuit 2**

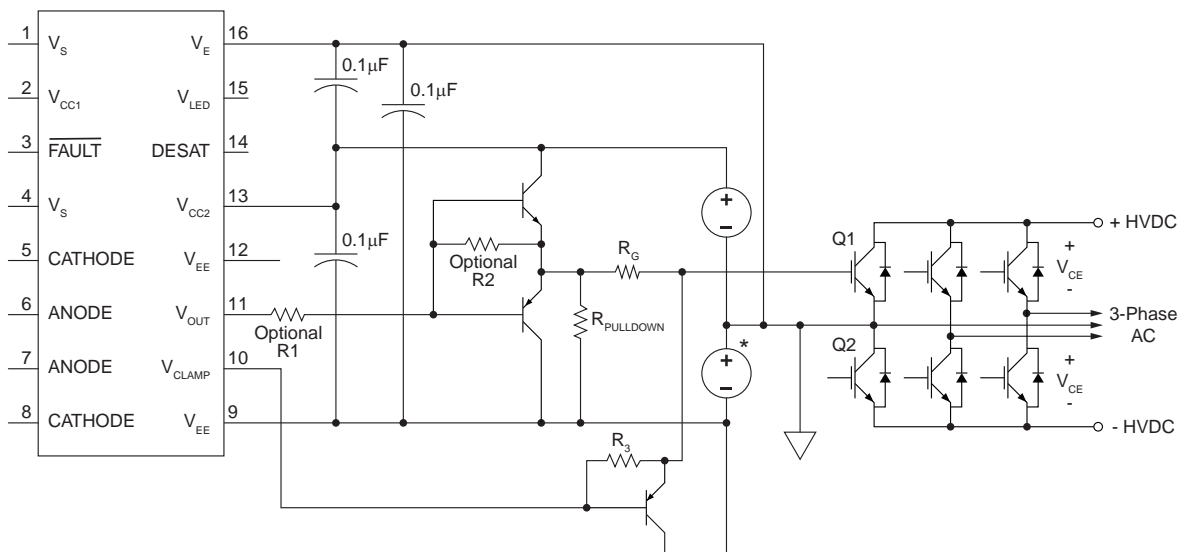

Large IGBT drive with negative gate drive, external booster.  $V_{CLAMP}$  control secondary discharge path for higher power application. \* indicates component required for negative gate drive topology.

## 4. Manufacturing Information

### 4.1 Moisture Sensitivity



All plastic encapsulated semiconductor packages are susceptible to moisture ingress. IXYS Integrated Circuits Division classifies its plastic encapsulated devices for moisture sensitivity according to the latest version of the joint industry standard, **IPC/JEDEC J-STD-020**, in force at the time of product evaluation.

We test all of our products to the maximum conditions set forth in the standard, and guarantee proper operation of our devices when handled according to the limitations and information in that standard as well as to any limitations set forth in the information or standards referenced below.

Failure to adhere to the warnings or limitations as established by the listed specifications could result in reduced product performance, reduction of operable life, and/or reduction of overall reliability.

This product carries a **Moisture Sensitivity Level (MSL)** classification as shown below, and should be handled according to the requirements of the latest version of the joint industry standard **IPC/JEDEC J-STD-033**.

Device	Moisture Sensitivity Level (MSL) Classification
IX332B	MSL 1

### 4.2 ESD Sensitivity



This product is **ESD Sensitive**, and should be handled according to the industry standard **JESD-625**.

### 4.3 Soldering Profile

Provided in the table below is the Classification Temperature ( $T_C$ ) of this product and the maximum dwell time the body temperature of this device may be ( $T_C - 5$ )°C or greater. The classification temperature sets the Maximum Body Temperature allowed for this device during lead-free reflow processes. For through-hole devices, and any other processes, the guidelines of J-STD-020 must be observed.

Device	Classification Temperature ( $T_C$ )	Dwell Time ( $t_p$ )	Max Reflow Cycles
IX332B	260°C	30 seconds	3

### 4.4 Board Wash

IXYS Integrated Circuits Division recommends the use of no-clean flux formulations. Board washing to reduce or remove flux residue following the solder reflow process is acceptable provided proper precautions are taken to prevent damage to the device. These precautions include but are not limited to: using a low pressure wash and providing a follow up bake cycle sufficient to remove any moisture trapped within the device due to the washing process. Due to the variability of the wash parameters used to clean the board, determination of the bake temperature and duration necessary to remove the moisture trapped within the package is the responsibility of the user (assembler). Cleaning or drying methods that employ ultrasonic energy may damage the device and should not be used. Additionally, the device must not be exposed to flux or solvents that are Chlorine- or Fluorine-based.



### 4.5 Package Mechanical Dimensions

#### 4.5.1 IX332B 16-Pin SOIC

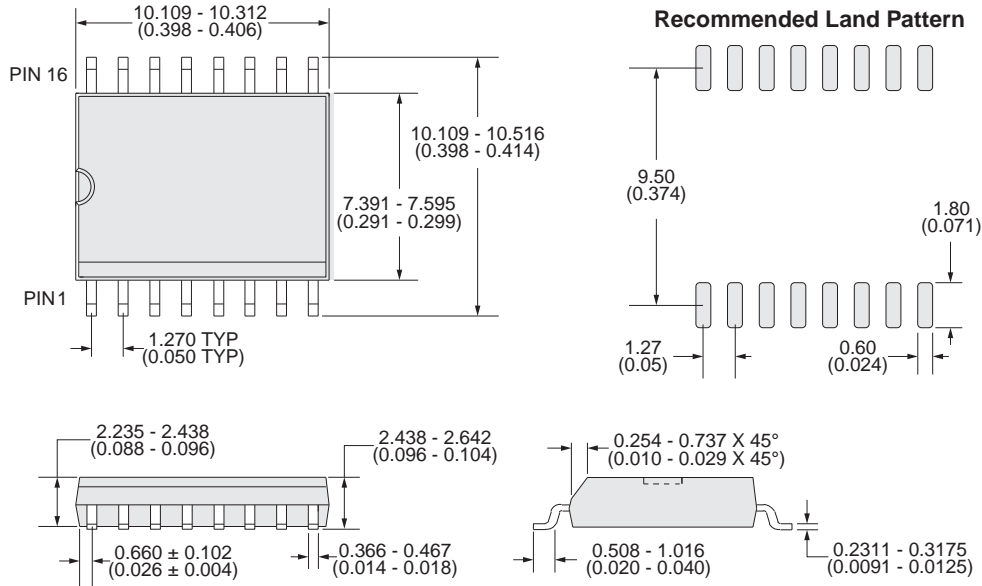

- NOTES:
1. Coplanarity = 0.1016 (0.004) max.
  2. Leadframe thickness does not include solder plating (1000 microinch maximum).

DIMENSIONS  
mm MIN - mm MAX  
(inches MIN - inches MAX)

#### 4.5.2 IX332BTR Tape & Reel

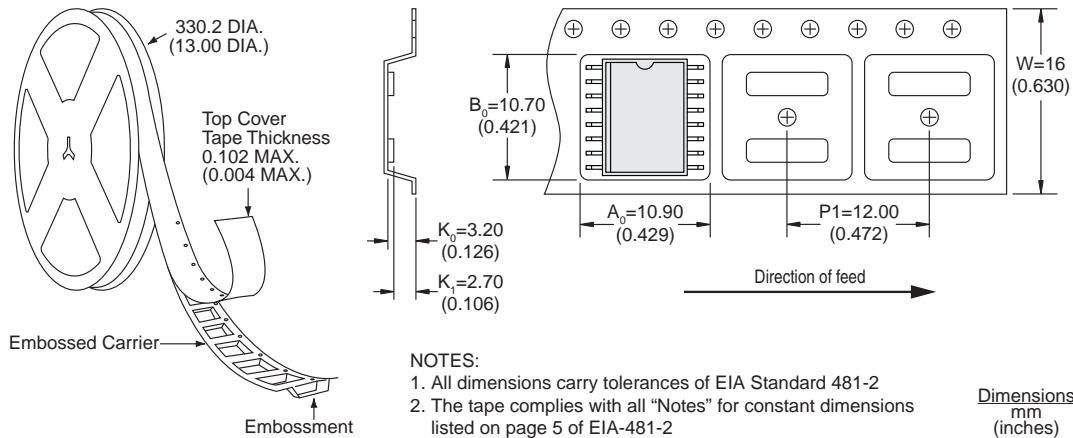

- NOTES:
1. All dimensions carry tolerances of EIA Standard 481-2
  2. The tape complies with all "Notes" for constant dimensions listed on page 5 of EIA-481-2

Dimensions  
mm  
(inches)

For additional information please visit our website at: [www.ixysic.com](http://www.ixysic.com)

IXYS Integrated Circuits Division makes no representations or warranties with respect to the accuracy or completeness of the contents of this publication and reserves the right to make changes to specifications and product descriptions at any time without notice. Neither circuit patent licenses nor indemnity are expressed or implied. Except as set forth in IXYS Integrated Circuits Division's Standard Terms and Conditions of Sale, IXYS Integrated Circuits Division assumes no liability whatsoever, and disclaims any express or implied warranty, relating to its products including, but not limited to, the implied warranty of merchantability, fitness for a particular purpose, or infringement of any intellectual property right.

The products described in this document are not designed, intended, authorized or warranted for use as components in systems intended for surgical implant into the body, or in other applications intended to support or sustain life, or where malfunction of IXYS Integrated Circuits Division's product may result in direct physical harm, injury, or death to a person or severe property or environmental damage. IXYS Integrated Circuits Division reserves the right to discontinue or make changes to its products at any time without notice.

Specification: DS-IX332B-R01  
©Copyright 2019, IXYS Integrated Circuits Division  
All rights reserved. Printed in USA.  
2/1/2019

## X-ON Electronics

Largest Supplier of Electrical and Electronic Components

*Click to view similar products for [Logic Output Opto-couplers](#) category:*

*Click to view products by [IXYS](#) manufacturer:*

Other Similar products are found below :

[CPC1590P](#) [TLP705A\(F\)](#) [TLP700A\(F\)](#) [TLP701A\(F\)](#) [FOD3150](#) [VO3120-X001](#) [ACPL-W343-560E](#) [ACPL-W340-560E](#) [H11L2S\(TA\)-V](#)  
[ACNW3410-500E](#) [ACPL-P347-500E](#) [ACPL-P347-560E](#) [ACNT-H343-500E](#) [H11L1S\(TA\)](#) [H11L3SR2M](#) [HCPL3700SD](#) [HCPL-J312-000E](#)  
[TLP155E\(TPL,E\)](#) [TLP2348\(E,T](#) [TLP350H\(F\)](#) [TLP701AF\(F\)](#) [MID400](#) [FOD8333](#) [TLP351H\(F\)](#) [TLP5214\(TP,E\(O](#) [TLP5702\(TP,E](#)  
[TLP351H\(TP1,F\)](#) [FOD3120SDV](#) [FOD8160](#) [6N140A/883B](#) [HCPL-0466-500E](#) [HCPL-6750](#) [TLP700AF\(F\)](#) [TLP152\(TPL,E](#) [HCPL-5730](#)  
[OPIA804DTUE](#) [8302401EA](#) [H11L1](#) [TLP250\(F\)](#) [VO3150A-X017T](#) [TLP5774\(TP,E](#) [TLP5214A\(D4-TP,E](#) [TLP351H\(D4-TP1,F\)](#) [ACPL-P314-](#)  
[000E](#) [FOD8333R2](#) [ACNW3190-300E](#) [ACPL-32JT-500E](#) [ACPL-3130-000E](#) [ACPL-331J-500E](#) [ACPL-332J-500E](#)