

High Speed IGBT with Diode

IXSA 10N60B2D1
IXSP 10N60B2D1

$V_{CES} = 600\text{ V}$
 $I_{C25} = 20\text{ A}$
 $V_{CE(sat)} = 2.5\text{ V}$

Short Circuit SOA Capability

Preliminary Data Sheet

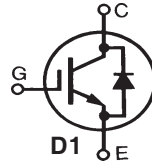

| Symbol | Test Conditions | Maximum Ratings | |
|---|---|----------------------------------|------------------|
| V_{CES} | $T_J = 25^\circ\text{C to } 150^\circ\text{C}$ | 600 | V |
| V_{CGR} | $T_J = 25^\circ\text{C to } 150^\circ\text{C}; R_{GE} = 1\text{ M}\Omega$ | 600 | V |
| V_{GES} | Continuous | ± 20 | V |
| V_{GEM} | Transient | ± 30 | V |
| I_{C25} | $T_C = 25^\circ\text{C}$ | 20 | A |
| I_{C110} | $T_C = 110^\circ\text{C}$ | 10 | A |
| $I_{F(110)}$ | | 11 | A |
| I_{CM} | $T_C = 25^\circ\text{C}, 1\text{ ms}$ | 30 | A |
| SSOA (RBSOA) | $V_{GE} = 15\text{ V}, T_J = 125^\circ\text{C}, R_G = 82\Omega$ Clamped inductive load, $V_{GE} = 20\text{ V}$ | $I_{CM} = 20$ @ $0.8 V_{CES}$ | A |
| t_{SC} (SCSOA) | $V_{GE} = 15\text{ V}, V_{CE} = 360\text{ V}, T_J = 125^\circ\text{C}$ $R_G = 150\ \Omega$, non repetitive | 10 | μs |
| P_C | $T_C = 25^\circ\text{C}$ | 100 | W |
| T_J | | -55 ... +150 | $^\circ\text{C}$ |
| T_{JM} | | 150 | $^\circ\text{C}$ |
| T_{stg} | | -55 ... +150 | $^\circ\text{C}$ |
| Maximum lead temperature for soldering 1.6 mm (0.062 in.) from case for 10 s | | 300 | $^\circ\text{C}$ |
| Plastic Body $t = 10\text{ s}$ | | 250 | $^\circ\text{C}$ |
| M_d | Mounting torque | (TO-220) 1.3/10 | Nm/lb. in |
| Weight | | 2 | g |

TO-263 (IXSA)

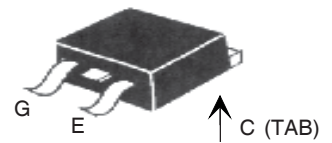

TO-220AB (IXSP)

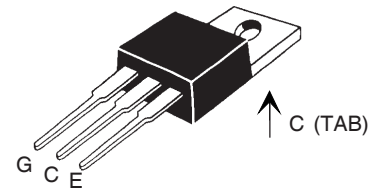

G = Gate C = Collector
E = Emitter TAB = Collector

Features

- International standard packages
- Guaranteed Short Circuit SOA capability
- Low $V_{CE(sat)}$
 - for low on-state conduction losses
- High current handling capability
- MOS Gate turn-on
 - drive simplicity
- Fast fall time for switching speeds up to 20 kHz

Applications

- AC motor speed control
- Uninterruptible power supplies (UPS)
- Welding

Advantages

- High power density

| Symbol | Test Conditions | Characteristic Values ($T_J = 25^\circ\text{C}$, unless otherwise specified) | | |
|---------------|---|---|------|---------------------------------------|
| | | min. | typ. | max. |
| $V_{GE(th)}$ | $I_C = 750\ \mu\text{A}, V_{CE} = V_{GE}$ | 4.0 | | 7.0 V |
| I_{CES} | $V_{CE} = V_{CES}$ $V_{GE} = 0\text{ V}$ | | | 75 μA 200 μA |
| I_{GES} | $V_{CE} = 0\text{ V}, V_{GE} = \pm 20\text{ V}$ | | | $\pm 100\text{ nA}$ |
| $V_{CE(sat)}$ | $I_C = 10\text{ A}, V_{GE} = 15\text{ V}$ | | | 2.5 V |

| Symbol | Test Conditions | Characteristic Values ($T_J = 25^\circ\text{C}$, unless otherwise specified) | | |
|--------------|---|---|------|-------------------|
| | | min. | typ. | max. |
| g_{fs} | $I_C = 10\text{A}; V_{CE} = 10\text{V}$, Note 1 | 2.0 | 3.6 | S |
| C_{ies} | | | 400 | pF |
| C_{oes} | $V_{CE} = 25\text{V}, V_{GE} = 0\text{V}$ | | 50 | pF |
| C_{res} | $f = 1\text{MHz}$ | | 11 | pF |
| Q_g | | | 17 | nC |
| Q_{ge} | $I_C = 10\text{A}, V_{GE} = 15\text{V}, V_{CE} = 0.5 V_{CES}$ | | 6 | nC |
| Q_{gc} | | | 7.5 | nC |
| $t_{d(on)}$ | Inductive load, $T_J = 25^\circ\text{C}$ | | 30 | ns |
| t_{ri} | $I_C = 10\text{A}, V_{GE} = 15\text{V}$ | | 30 | ns |
| $t_{d(off)}$ | $V_{CE} = 0.8 V_{CES}, R_G = 30\ \Omega$ | | 180 | ns |
| t_{fi} | Switching times may increase for V_{CE} (Clamp) $> 0.8 \cdot V_{CES}$, higher T_J or increased R_G | | 165 | ns |
| E_{off} | | | 430 | 750 μJ |
| $t_{d(on)}$ | | | 30 | ns |
| t_{ri} | Inductive load, $T_J = 125^\circ\text{C}$ | | 30 | ns |
| E_{on} | $I_C = 10\text{A}, V_{GE} = 15\text{V}$ | | 0.32 | mJ |
| $t_{d(off)}$ | $V_{CE} = 0.8 V_{CES}, R_G = 30\ \Omega$ | | 260 | ns |
| t_{fi} | Switching times may increase for V_{CE} (Clamp) $> 0.8 \cdot V_{CES}$, higher T_J or increased R_G | | 270 | ns |
| E_{off} | | | 790 | μJ |
| R_{thJC} | | | | 1.25 K/W |
| R_{thCS} | TO-220 | | 0.25 | K/W |

TO-220 AB (IXSP) Outline

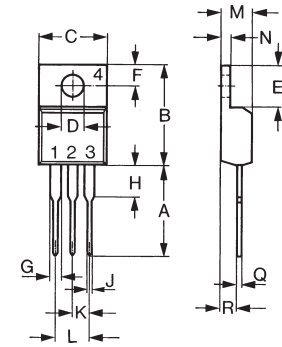

| Dim. | Millimeter | | Inches | |
|------|------------|-------|--------|-------|
| | Min. | Max. | Min. | Max. |
| A | 12.70 | 13.97 | 0.500 | 0.550 |
| B | 14.73 | 16.00 | 0.580 | 0.630 |
| C | 9.91 | 10.66 | 0.390 | 0.420 |
| D | 3.54 | 4.08 | 0.139 | 0.161 |
| E | 5.85 | 6.85 | 0.230 | 0.270 |
| F | 2.54 | 3.18 | 0.100 | 0.125 |
| G | 1.15 | 1.65 | 0.045 | 0.065 |
| H | 2.79 | 5.84 | 0.110 | 0.230 |
| J | 0.64 | 1.01 | 0.025 | 0.040 |
| K | 2.54 | BSC | 0.100 | BSC |
| M | 4.32 | 4.82 | 0.170 | 0.190 |
| N | 1.14 | 1.39 | 0.045 | 0.055 |
| Q | 0.35 | 0.56 | 0.014 | 0.022 |
| R | 2.29 | 2.79 | 0.090 | 0.110 |

TO-263 (IXSA) Outline

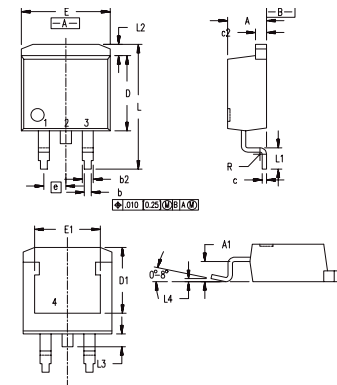

| Dim. | Millimeter | | Inches | |
|------|------------|-------|--------|------|
| | Min. | Max. | Min. | Max. |
| A | 4.06 | 4.83 | .160 | .190 |
| A1 | 2.03 | 2.79 | .080 | .110 |
| b | 0.51 | 0.99 | .020 | .039 |
| b2 | 1.14 | 1.40 | .045 | .055 |
| c | 0.46 | 0.74 | .018 | .029 |
| c2 | 1.14 | 1.40 | .045 | .055 |
| D | 8.64 | 9.65 | .340 | .380 |
| D1 | 7.11 | 8.13 | .280 | .320 |
| E | 9.65 | 10.29 | .380 | .405 |
| E1 | 6.86 | 8.13 | .270 | .320 |
| e | 2.54 | BSC | .100 | BSC |
| L | 14.61 | 15.88 | .575 | .625 |
| L1 | 2.29 | 2.79 | .090 | .110 |
| L2 | 1.02 | 1.40 | .040 | .055 |
| L3 | 1.27 | 1.78 | .050 | .070 |
| L4 | 0 | 0.38 | 0 | .015 |
| R | 0.46 | 0.74 | .018 | .029 |

| Symbol | Test Conditions | Characteristic Values ($T_J = 25^\circ\text{C}$, unless otherwise specified) | | |
|------------|--|---|------|------------------|
| | | min. | typ. | max. |
| V_F | $I_F = 10\text{A}, V_{GE} = 0\text{V}$ | $T_J = 150^\circ\text{C}$ | | 1.66 V 2.66 V |
| I_{RM} | $I_F = 12\text{A}, V_{GE} = 0\text{V}, -di_F/dt = 100\text{A}/\mu\text{s}$ | $T_J = 100^\circ\text{C}$ | 1.5 | A |
| t_{rr} | $V_R = 100\text{V}$ | $T_J = 100^\circ\text{C}$ | 90 | ns |
| t_{rr} | $I_F = 1\text{A}; -di/dt = 100\text{A}/\mu\text{s}; V_R = 30\text{V}$ | | 25 | ns |
| R_{thJC} | | | | 2.5 K/W |

Note 1: Pulse test, $t \leq 300\ \mu\text{s}$, duty cycle $d \leq 2\%$

IXYS reserves the right to change limits, test conditions, and dimensions.

| | | | | | | | | |
|--|-----------|-----------|-----------|-----------|--------------|--------------|--------------|-----------|
| IXYS MOSFETs and IGBTs are covered by one or more of the following U.S. patents: | 4,835,592 | 4,931,844 | 5,049,961 | 5,237,481 | 6,162,665 | 6,404,065 B1 | 6,683,344 | 6,727,585 |
| | 4,850,072 | 5,017,508 | 5,063,307 | 5,381,025 | 6,259,123 B1 | 6,534,343 | 6,710,405 B2 | |
| | 4,881,106 | 5,034,796 | 5,187,117 | 5,486,715 | 6,306,728 B1 | 6,583,505 | 6,710,463 | |

Fig. 1. Output Characteristics @ 25 °C

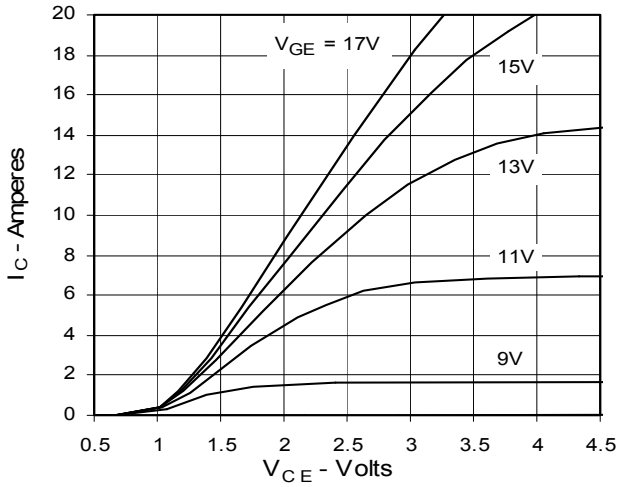

Fig. 2. Extended Output Characteristics @ 25 °C

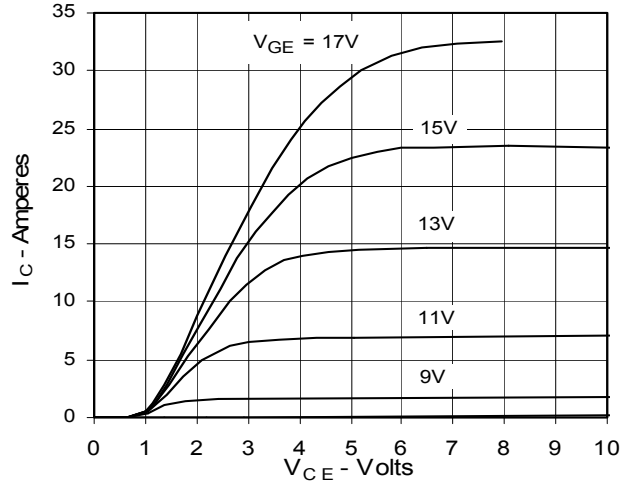

Fig. 3. Output Characteristics @ 125 °C

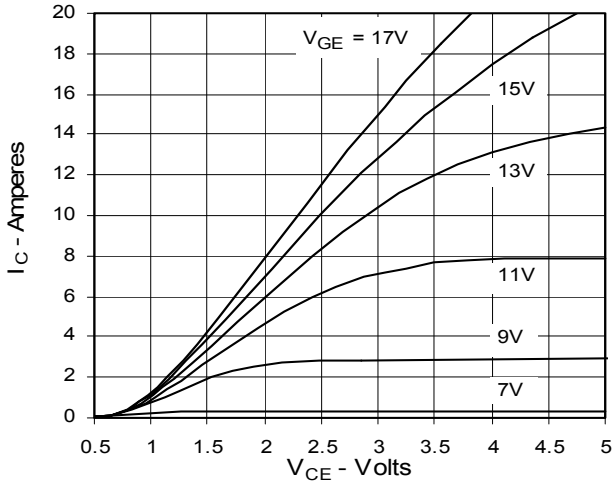

Fig. 4. Dependence of $V_{CE(sat)}$ on Temperature

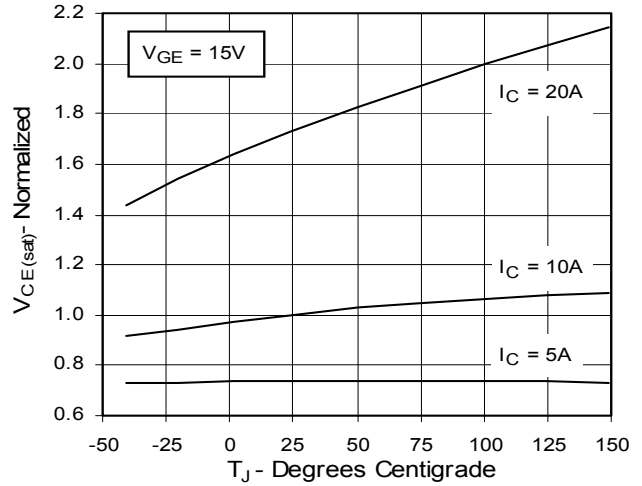

Fig. 5. Collector-to-Emitter Voltage vs. Gate-to-Emitter voltage

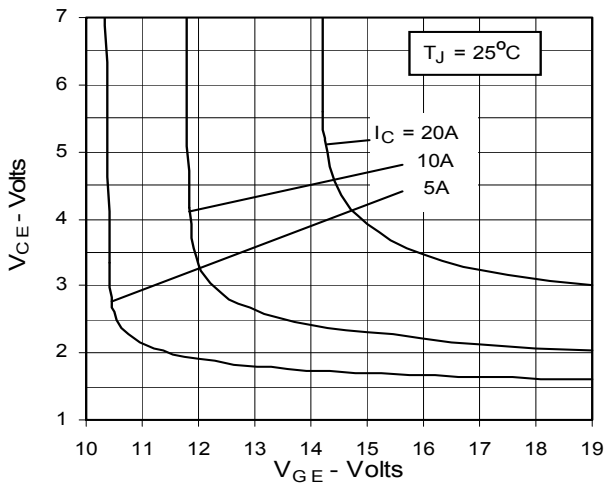

Fig. 6. Input Admittance

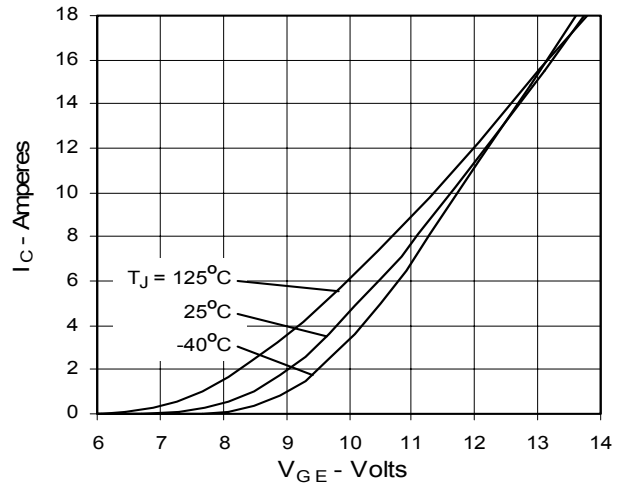

Fig. 7. Transconductance

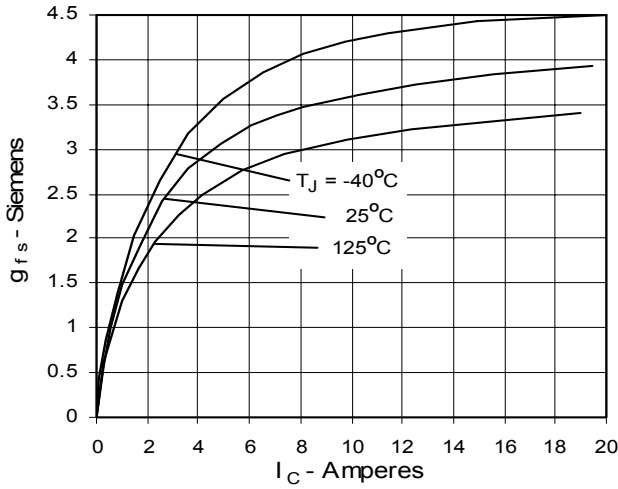

Fig. 8. Dependence of Turn-off Energy Loss on R_G

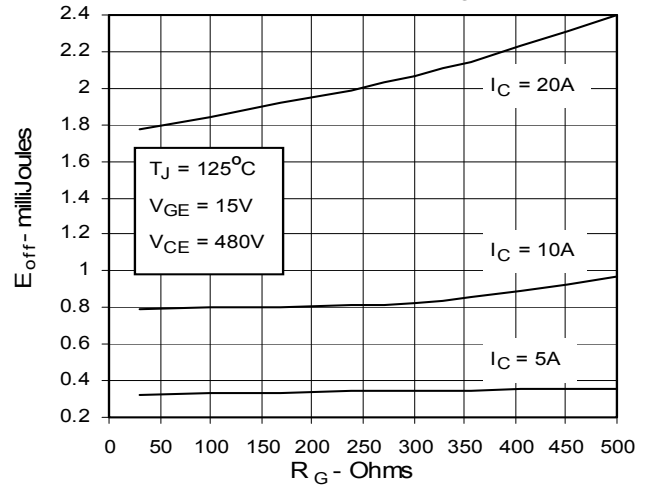

Fig. 9. Dependence of Turn-Off Energy Loss on I_C

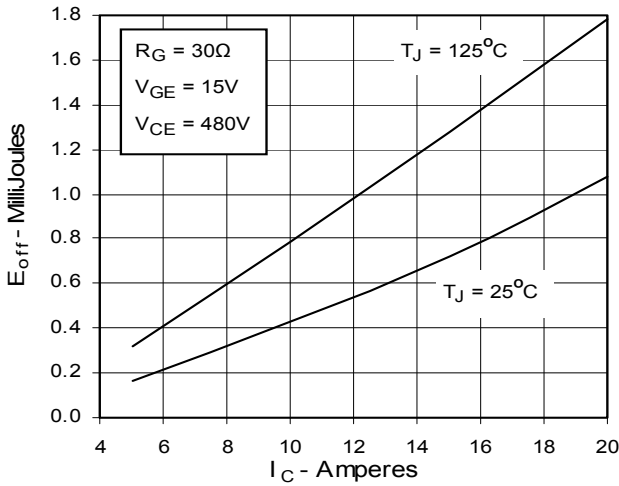

Fig. 10. Dependence of Turn-off Energy Loss on Temperature

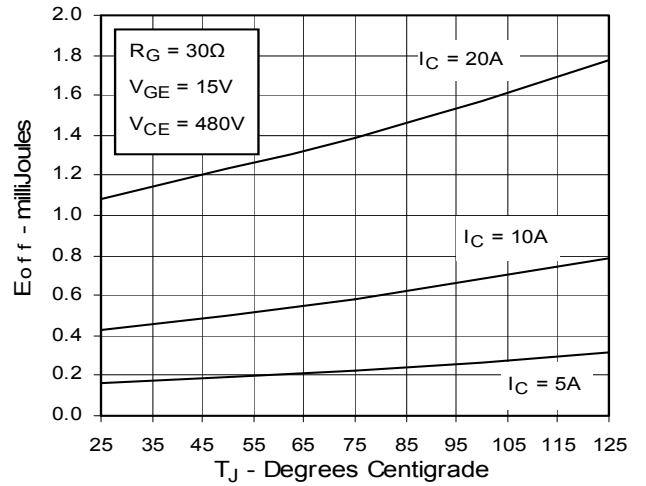

Fig. 11. Dependence of Turn-off Switching Time on R_G

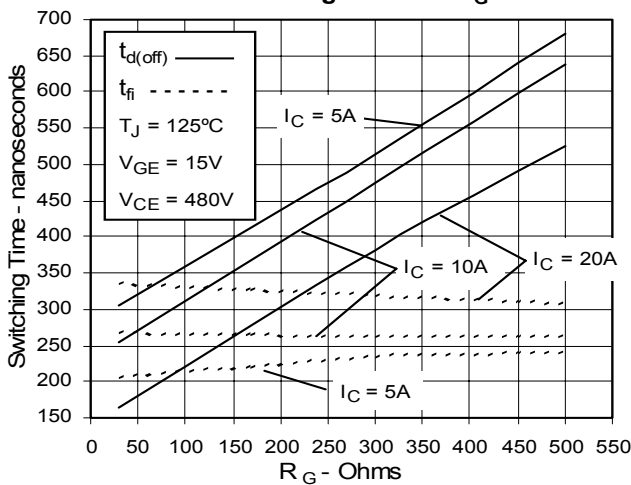

Fig. 12. Dependence of Turn-off Switching Time on I_C

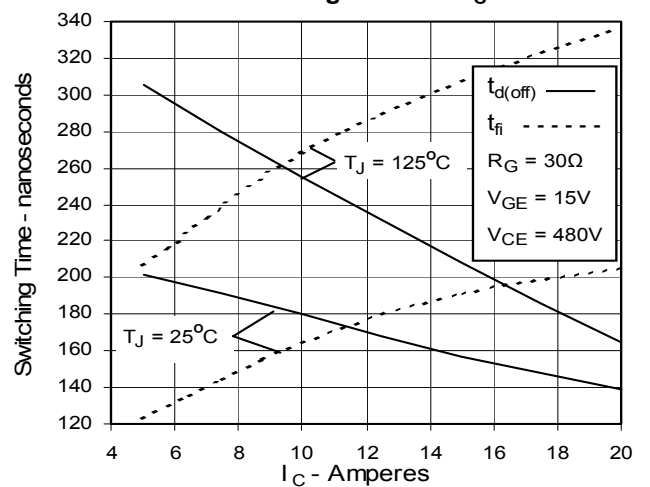

Fig. 13. Dependence of Turn-off Switching Time on Temperature

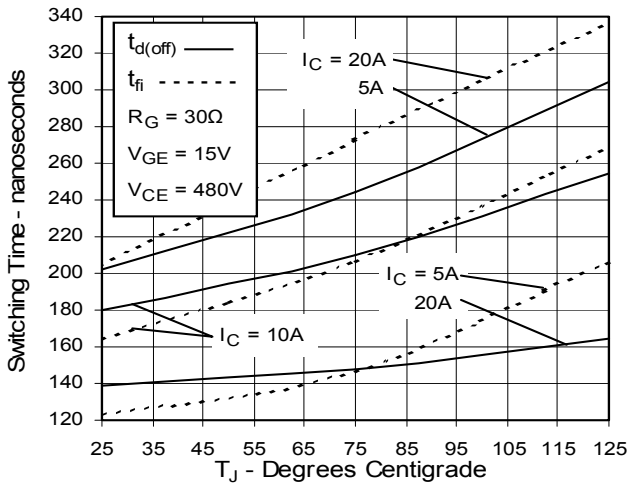

Fig. 14. Gate Charge

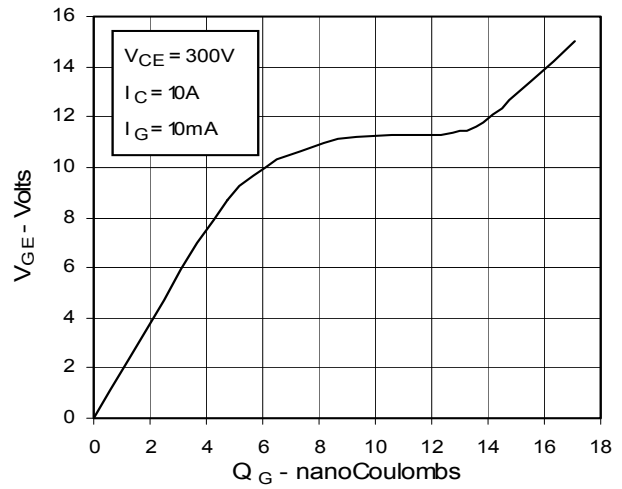

Fig. 15. Capacitance

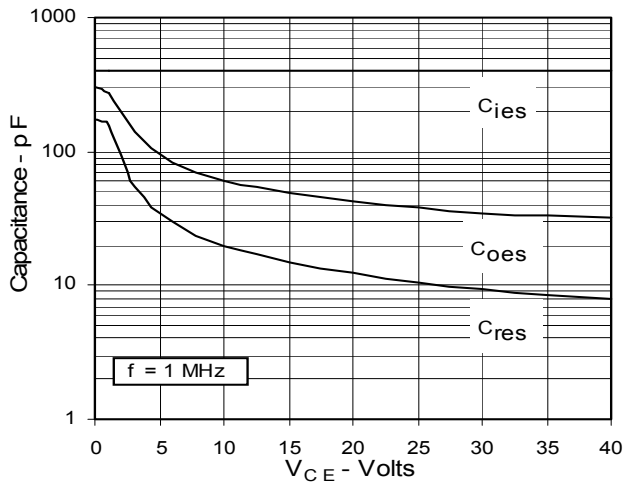

Fig. 16. Reverse-Bias Safe Operating Area

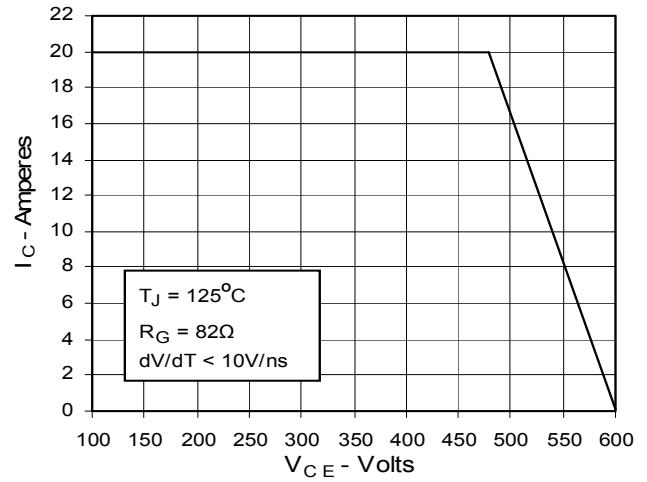
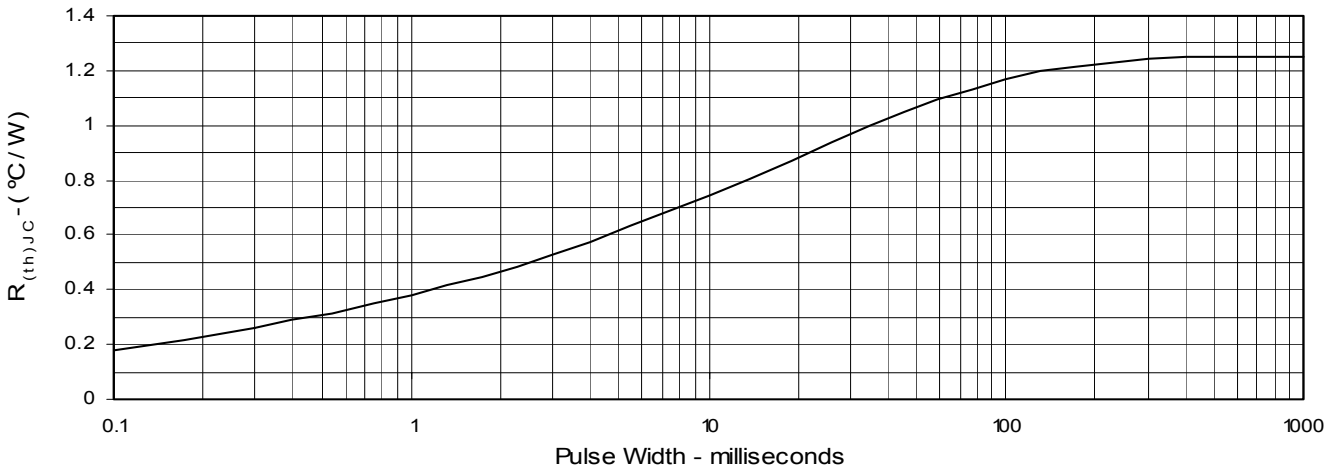

Fig. 17. Maximum Transient Thermal Resistance



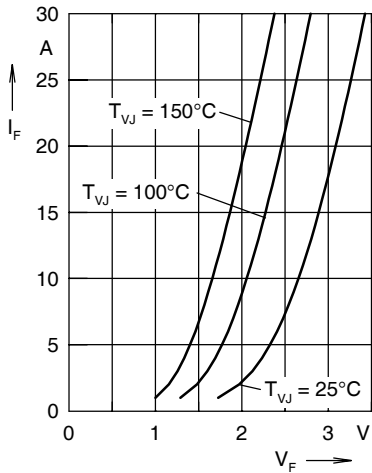

Fig. 18. Forward current I_F versus V_F

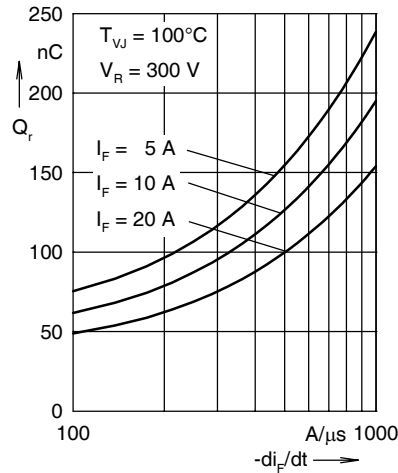

Fig. 19. Reverse recovery charge Q_r versus $-di_F/dt$

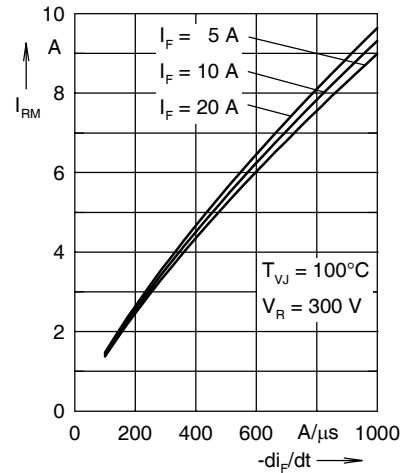

Fig. 20. Peak reverse current I_{RM} versus $-di_F/dt$

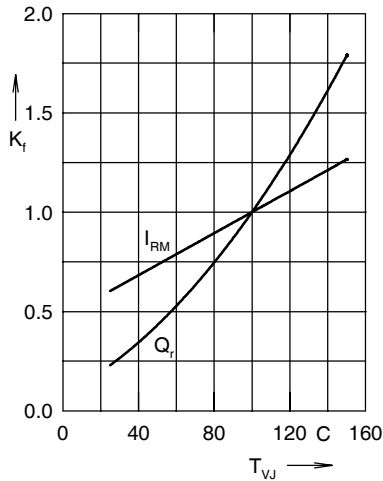

Fig. 21. Dynamic parameters Q_r , I_{RM} versus T_{VJ}

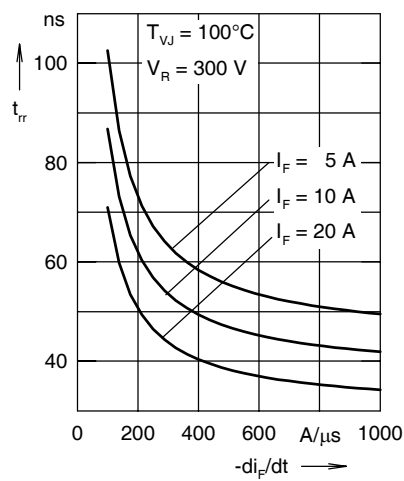

Fig. 22. Recovery time t_{rr} versus $-di_F/dt$

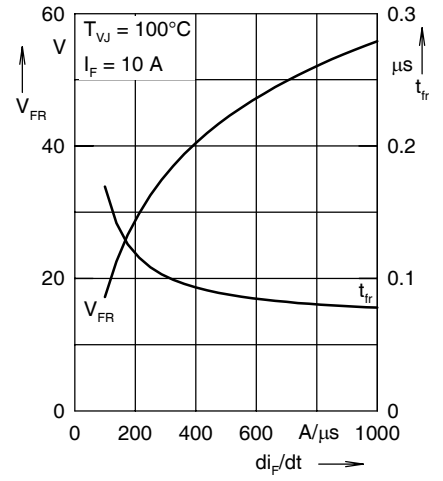

Fig. 23. Peak forward voltage V_{FR} and t_{fr} versus di_F/dt

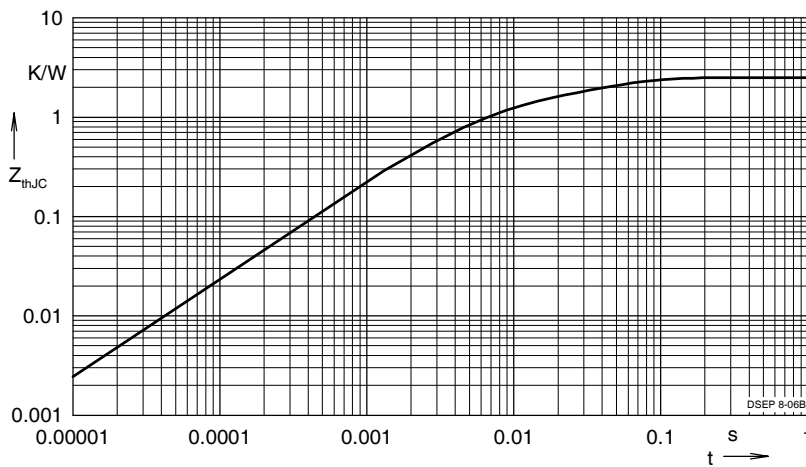

Fig. 24. Transient thermal resistance junction-to-case

NOTE: Fig. 19 to Fig. 23 shows typical values

Constants for Z_{thJC} calculation:

| i | R_{thi} (K/W) | t_i (s) |
|---|-----------------|-----------|
| 1 | 1.449 | 0.0052 |
| 2 | 0.5578 | 0.0003 |
| 3 | 0.4931 | 0.0169 |

IXYS reserves the right to change limits, test conditions, and dimensions.

IXYS MOSFETs and IGBTs are covered by one or more of the following U.S. patents:

| | | | | | | | | | |
|-----------|-----------|-----------|-----------|-----------|-----------|--------------|--------------|-----------|--------------|
| 4,835,592 | 4,881,106 | 5,017,508 | 5,049,961 | 5,187,117 | 5,381,025 | 6,162,665 | 6,306,728 B1 | 6,534,343 | 6,683,344 |
| 4,850,072 | 4,931,844 | 5,034,796 | 5,063,307 | 5,237,481 | 5,486,715 | 6,259,123 B1 | 6,404,065 B1 | 6,583,505 | 6,710,405 B2 |

X-ON Electronics

Largest Supplier of Electrical and Electronic Components

Click to view similar products for IXYS manufacturer:

Other Similar products are found below :

[CPC5603C](#) [MCC220-16io1](#) [MDD172-14N1](#) [MDD312-18N1](#) [MDD312-22N1](#) [MEK600-04DA](#) [MIXA30W1200TED](#) [MKI75-06A7](#) [DSA75-16B](#) [DSEI19-06AS](#) [DSS2X101-02A](#) [MUBW30-12A6K](#) [IXDH20N120D1](#) [IXDR30N120D1](#) [IXFN50N120SK](#) [IXFR26N120P](#) [IXGK50N60B](#) [NRND](#) [IQTQ36P15P](#) [LAA100P](#) [LAA120H](#) [LCA146A](#) [PM1204X1](#) [CYG2030](#) [MCC132-16io1](#) [MCC312-18io1](#) [MDD175-34N1](#) [MDO500-22N1](#) [MII300-12A4](#) [MKI75-06A7T](#) [IAA170P](#) [IXA17IF1200HJ](#) [IXBOD1-08](#) [IXBT6N170](#) [IXFB90N85X](#) [IXFN150N65X2](#) [IXFN80N50](#) [IXFP5N50P3](#) [IXTT40N50L2](#) [IXyH100N65C3](#) [LAA100L](#) [LCB110E](#) [DSSK48-0025B](#) [VUO62-08NO7](#) [VUO160-16NO7](#) [VUE50-12NO1](#) [PLA170S](#) [VUO160-12NO7](#) [MMO74-16IO6](#) [MEE75-12DA](#) [MDD95-12N1B](#)