

Features

- Low Input Voltage of 1.6V over temperature
- Precision reference, error amplifier, and optocoupler in a single package
- Voltage Reference: 1.299V \pm 0.5% @ 25°C
LIA135: \pm 1% @ -40°C to +85°C
LIA136: \pm 1.5% @ -40°C to +110°C
- LIA136: Reduced dark current at high temperature
- Common Mode Transient Immunity:
LIA135: 5V/ns
LIA136: 20V/ns
- Simplified frequency compensation
- CTR 500% to 2000%
- Lowest optical offset current (I_{CE} vs. V_{LED})

Applications

- Low Voltage Power Supply Feedback
- Isolated Power Supply Feedback
- AC-to DC Power Supplies
- DC-to-DC Converters

Description

The LIA135 and LIA136 are low voltage optically isolated error amplifiers with a precision programmable shunt reference combined into a single package capable of operating down to 1.6V. The optocoupler portion of the LIA135 / LIA136 comprises an infrared LED that is optically coupled to an NPN phototransistor providing a current transfer ratio from 500% to 2000%. Ensuring low voltage performance, the input voltage range of 1.6V to 10V is guaranteed over the operational temperature range.

The combination of features in the LIA135 / LIA136 are optimal for use in isolated AC-to-DC power supplies and DC-to-DC converters. The bias current for the shunt regulator does not pass through the LED, which eliminates bias-related optical current, giving the user the industry's largest dynamic range (1000:1).

These devices are available in DIP and surface mount (SMT) packages.

Approvals

- UL Recognized Component: File # E76270
- CSA Certified Component: Certificate # 1305490

Ordering Information

| Part | Description |
|-----------|--|
| LIA135 | 8-pin DIP, Tube (50/Tube) |
| LIA135S | 8-pin Surface Mount, Tube (50/Tube) |
| LIA135STR | 8-pin Surface Mount, Tape & Reel (1000/Reel) |
| LIA136 | 8-pin DIP, Tube (50/Tube) |
| LIA136S | 8-pin Surface Mount, Tube (50/Tube) |
| LIA136STR | 8-pin Surface Mount, Tape & Reel (1000/Reel) |



LIA135 and LIA136 Block Diagrams

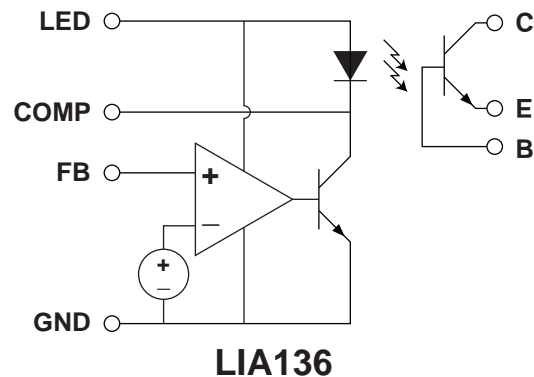
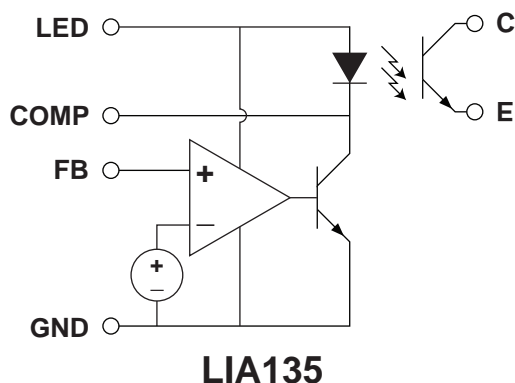

| | |
|--|-----------|
| 1. Specifications | 3 |
| 1.1 Package Pinout | 3 |
| 1.2 Pin Description | 3 |
| 1.3 Absolute Maximum Ratings | 3 |
| 1.4 Electrical Characteristics | 4 |
| 1.5 Test Diagrams | 5 |
| 1.6 Performance Data | 7 |
| 2. Functional Description | 8 |
| 2.1 Input Side Biasing | 9 |
| 2.2 Supply Regulation | 9 |
| 2.3 Compensation | 9 |
| 2.4 Optocoupler Output Transistor | 9 |
| 2.5 N/C Pins | 9 |
| 3. Design Examples | 10 |
| 3.1 Error Amplifier Input Configuration | 10 |
| 3.2 Discrete Optocoupler Output Resistor | 10 |
| 3.3 Integrated Optocoupler Output Resistor | 10 |
| 4. Manufacturing Information | 11 |
| 4.1 Moisture Sensitivity | 11 |
| 4.2 ESD Sensitivity | 11 |
| 4.3 Soldering Profile | 11 |
| 4.4 Board Wash | 11 |
| 4.5 Mechanical Dimensions | 12 |

1. Specifications

1.1 Package Pinout

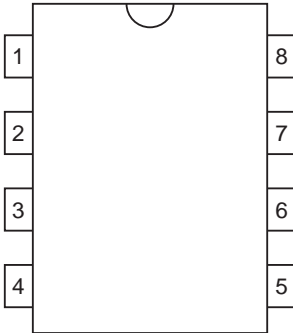

1.2 Pin Description

| Pin# | Name | Description |
|------|------|---|
| 1 | N/C | No Connect - not used |
| 2 | N/C | LIA135: No Connect - not used |
| | B | LIA136: Phototransistor Base |
| 3 | C | Phototransistor Collector |
| 4 | E | Phototransistor Emitter |
| 5 | LED | LED Anode and Input Side Power |
| 6 | COMP | Error Amplifier Compensation (Error amplifier output) |
| 7 | GND | Ground (Secondary side of supply) |
| 8 | FB | Feedback Input (Error Amplifier Input / Summing node) |

1.3 Absolute Maximum Ratings

| Parameter | Symbol | Ratings | Unit |
|--|--------------|-------------|-----------|
| Collector-Emitter Voltage | V_{CEO} | 25 | V |
| Emitter-Collector Voltage | V_{ECO} | 7 | V |
| Collector Current | I_{CE} | 50 | mA |
| Input Voltage (Referenced to GND) | V_{LED} | 15 | V |
| Input DC Current | I_{LED} | 20 | mA |
| Input Power Dissipation ¹ | $P_{D(IN)}$ | 145 | mW |
| Transistor Power Dissipation ² | $P_{D(NPN)}$ | 85 | mW |
| Total Power Dissipation ¹ | P_D | 145 | mW |
| Isolation Voltage, Input Side to Output Side | V_{IO} | 3750 | V_{rms} |
| Operating Temperature: | T_A | | |
| LIA135 | | -40 to +85 | °C |
| LIA136 | | -40 to +110 | °C |
| Storage Temperature | T_{STG} | -55 to +125 | °C |

¹ Derate linearly from 25°C at a rate of 2.42mW/°C.

² Derate linearly from 25°C at a rate of 1.42mW/°C.

Unless otherwise specified, Absolute Maximum ratings are at 25°C. Absolute Maximum Ratings are stress ratings. Stresses in excess of these ratings can cause permanent damage to the device. Functional operation of the device at these or any other conditions beyond those indicated in the operational sections of this data sheet is not implied.

Typical values are characteristic of the device at 25°C, and are the result of engineering evaluations. They are provided for information purposes only, and are not part of the manufacturing testing requirements.

1.4 Electrical Characteristics

| Parameter | Symbol | Conditions | Min | Typ | Max | Unit |
|---|---|---|-------|-------|-------|------|
| Input Characteristics @ 25°C (Unless Otherwise Specified) | | | | | | |
| Input voltage | V _{LED} | LIA135: T _A =-40°C to +85°C | 1.6 | - | 10 | V |
| | | LIA136: T _A =-40°C to +110°C | | | | |
| LED forward voltage | V _F | V _{FB} =V _{COMP} =GND, I _{LED} =5mA (Fig. 1) | 0.9 | - | 1.4 | V |
| Reference voltage ¹ | V _{REF} | V _{LED} =1.6V, I _{LED} =10mA (Fig. 2) | 1.286 | 1.299 | 1.305 | V |
| | | T _A =25°C | | | | |
| | | LIA135: T _A =-40°C to +85°C | | | | |
| | | LIA136: T _A =-40°C to +110°C | | | | |
| Deviation of V _{REF} over temperature ² | V _{REF(DEV)} | V _{LED} =1.6V, I _{LED} =10mA, (Fig. 2) | - | 3 | 12 | mV |
| | | LIA135: T _A =-40°C to +85°C | - | 6 | 21 | |
| | | LIA136: T _A =-40°C to +110°C | - | 6 | 21 | |
| Ratio of V _{REF} variation to V _{LED} change | ΔV _{REF} /ΔV _{LED} | 1.6V ≤ V _{LED} ≤ 10V, I _{LED} =10mA (Fig. 2) | - | -0.37 | -2.7 | mV/V |
| FB input bias current | I _{IB} | V _{LED} =1.6V, I _{LED} =10mA (Fig. 2) | 0.1 | 0.34 | 0.5 | μA |
| Deviation of I _{IB} over temperature ² | I _{IB(DEV)} | V _{LED} =1.6V, I _{LED} =10mA, (Fig. 2) | - | 0.35 | 0.55 | μA |
| | | LIA135: T _A =-40°C to +85°C | | | | |
| | | LIA136: T _A =-40°C to +110°C | | | | |
| Quiescent bias current | I _Q | V _{LED} =1.6V, V _{FB} < V _{REF} , I _F =0mA (Fig. 5) | - | 75 | 100 | μA |
| Error amplifier Off-State current | I _{LED(off)} | V _{LED} =10V, V _{FB} =0V (Fig. 3) | - | 0.001 | 0.1 | μA |
| Shunt transconductance ³ | g _m (ΔI _{LED} /ΔV _{FB}) | V _{LED} =1.6V, I _{LED} = 0.2mA to 10mA @ f=1kHz (Fig. 2) | - | 1 | - | S |
| Output Characteristics @ 25°C (Unless Otherwise Specified) | | | | | | |
| Collector dark current | I _{CE} | V _{CE} =10V, R _B =1MΩ (Fig. 4) | - | 0.3 | 50 | nA |
| Collector-emitter breakdown voltage | BV _{CEO} | I _C =1mA | 20 | - | - | V |
| Emitter-collector breakdown voltage | BV _{ECO} | I _E =100μA | 7 | - | - | V |
| Transfer Characteristics @ 25°C (Unless Otherwise Specified) | | | | | | |
| Current transfer ratio | CTR | I _{LED} =5mA, V _{CE} =5V, R _B =1MΩ (Fig. 5) | 500 | - | 2000 | % |
| Bandwidth | B _W | (Fig. 7) | - | 10 | - | kHz |
| Collector-emitter saturation voltage | V _{CE(sat)} | I _{LED} =10mA, I _C =2.5mA, R _B =1MΩ (Fig. 5) | - | 0.099 | 0.5 | V |
| Minimal Operating Point Output Current ⁴ | I _{C(min)} | V _{LED} =10V (Fig. 6) | - | 1 | 10 | μA |
| | | LIA135: V _{FB} =1.258V, T _A = -40°C to +85°C | | | | |
| | | LIA136: V _{FB} =1.252V, R _B =1MΩ, T _A = -40°C to +110°C | | | | |
| Full-on Operating Point Output Current ⁴ | I _{C(on)} | V _{LED} =1.6V, (Fig. 6) | 10 | - | - | mA |
| | | LIA135: V _{FB} =1.307V, T _A = -40°C to +85°C | | | | |
| | | LIA136: V _{FB} =1.313V, R _B =1MΩ, T _A = -40°C to +110°C | | | | |
| Common Mode Transient Immunity Characteristics @ 25°C (Unless Otherwise Specified) | | | | | | |
| Output = High ⁵ | CM _H | I _{LED} =0mA, V _{CM} =10V _{PP} , R _C =2.2kΩ (Fig. 8) | - | 5 | - | V/ns |
| | | LIA135: | | | | |
| | | LIA136: R _B =1MΩ, C _B =100pF | | | | |
| Output = Low ⁵ | CM _L | I _{LED} =10mA, V _{CM} =10V _{PP} , R _C =2.2kΩ (Fig. 8) | - | 5 | - | V/ns |
| | | LIA135: | | | | |
| | | LIA136: R _B =1MΩ, C _B =100pF | | | | |

1 Reference voltage measured at Pin FB under the specified conditions.

2 Deviation parameters V_{REF(DEV)} and I_{IB(DEV)} are defined as the difference between the minimum and maximum values obtained over the rated temperature range.

3 With two external resistors, the total shunt transconductance of the circuit is defined as: $g'_m = g_m \left(\frac{R_2}{R_1 + R_2} \right)$

4 See **Figure 9: Operational Template on page 6.**

5 Common mode transient immunity at Output = High is the maximum positive dV_{CM}/dt on the rising edge of the common mode impulse signal, V_{CM}, to ensure the output will remain high. Common mode transient immunity at Output = Low is the maximum negative dV_{CM}/dt on the falling edge of the common pulse signal, V_{CM}, to ensure the output will remain low.

1.5 Test Diagrams

Figure 1: V_F Test Circuit

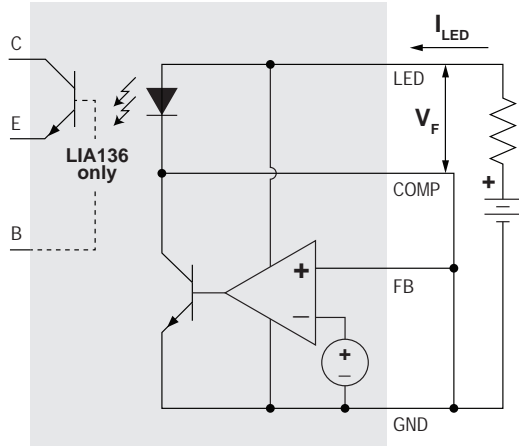

Figure 3: $I_{LED(off)}$ Test Circuit

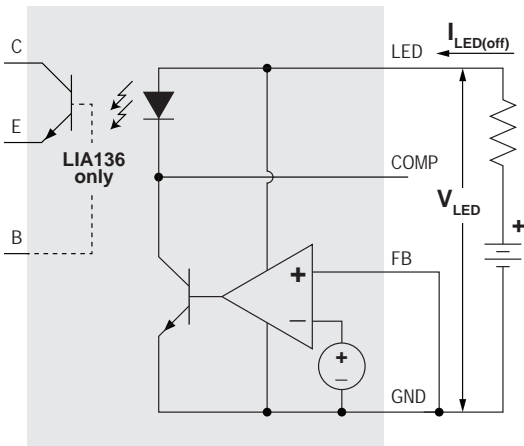

Figure 2: V_{REF} , I_B , $\Delta V_{REF}/\Delta V_{LED}$, g_m Test Circuit

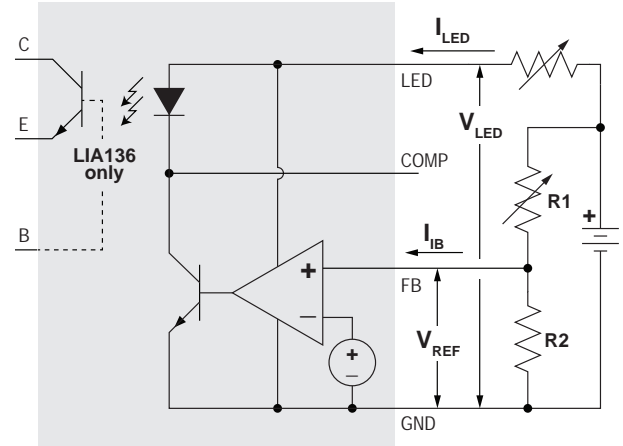

Figure 4: I_{CE} Test Circuit

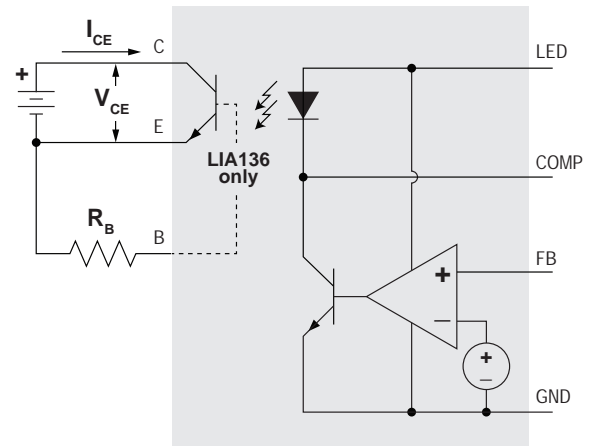

Figure 5: CTR , $V_{CE(sat)}$, Bias Current Test Circuit

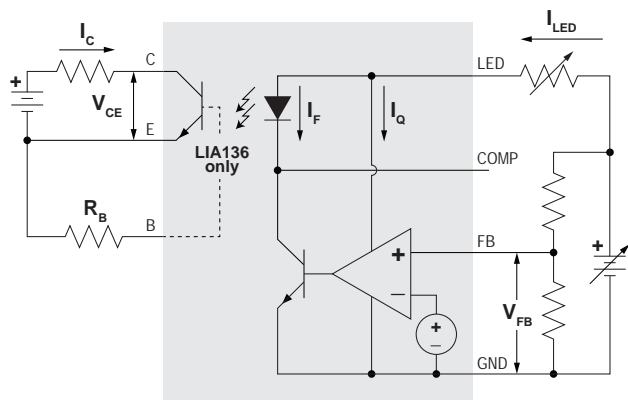

Figure 6: $I_{C(min)}$, $I_{C(on)}$ Test Circuit

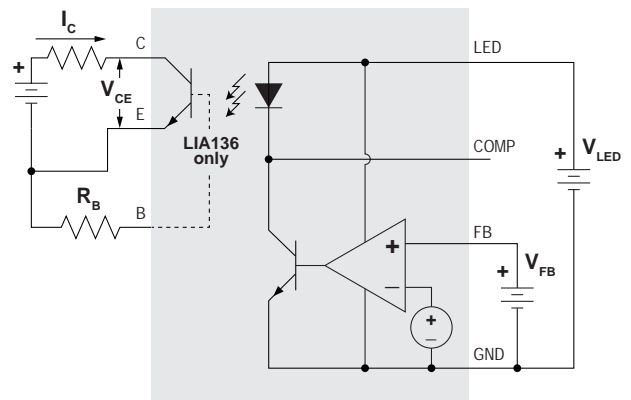

Figure 7: Frequency Response Test Circuit

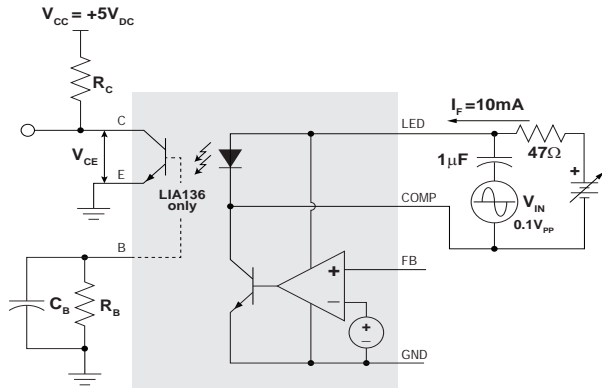

Figure 8: CM_H and CM_L Test Circuit

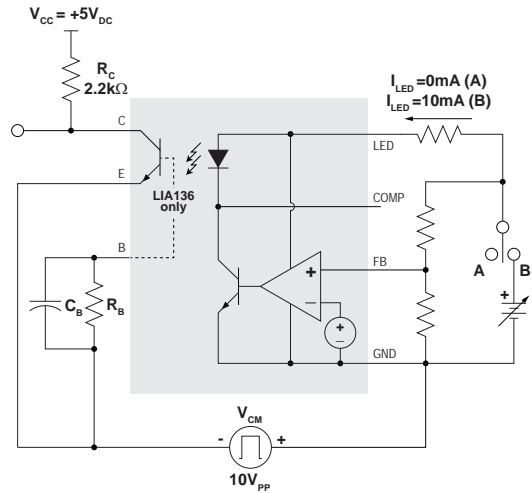
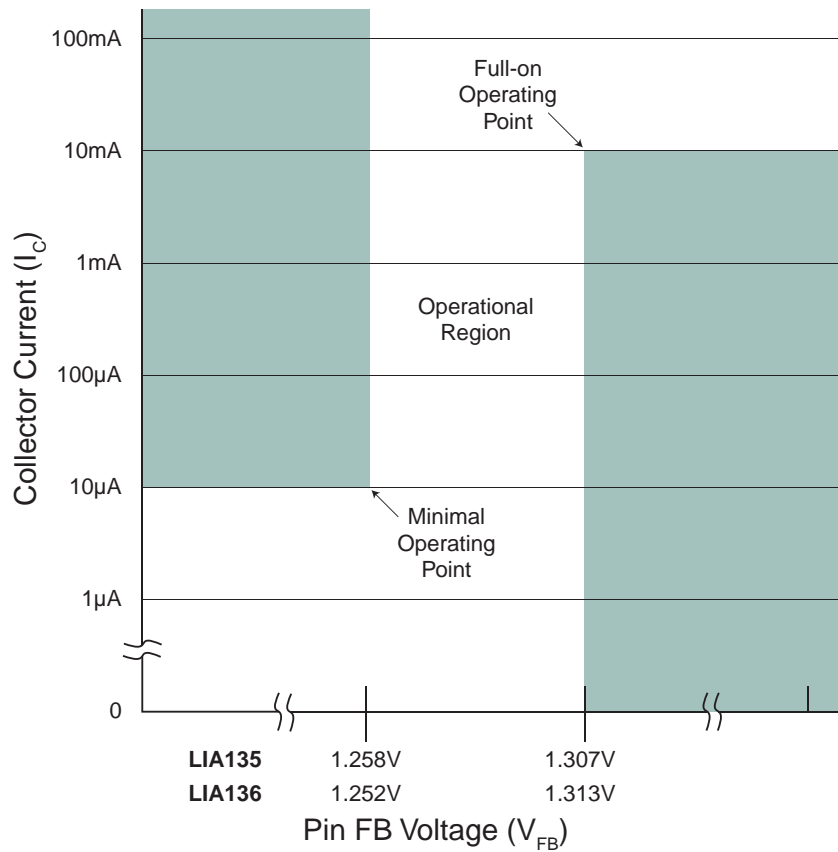
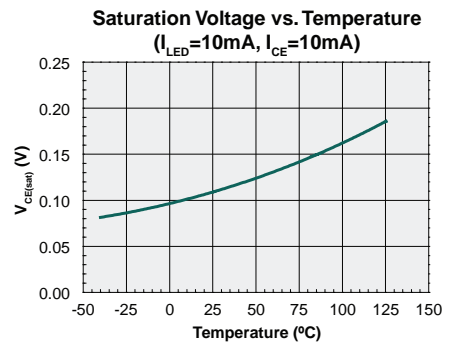
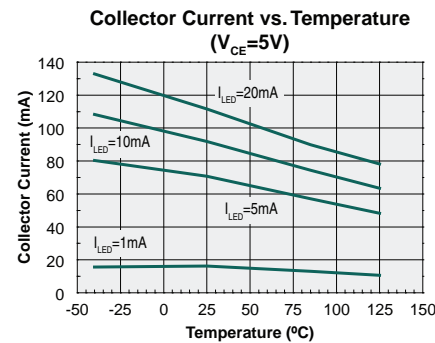
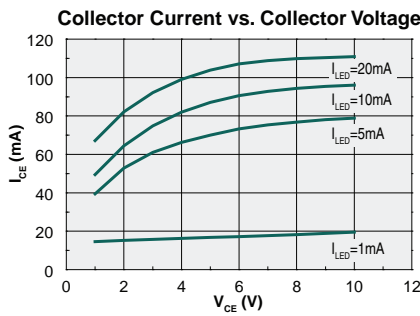
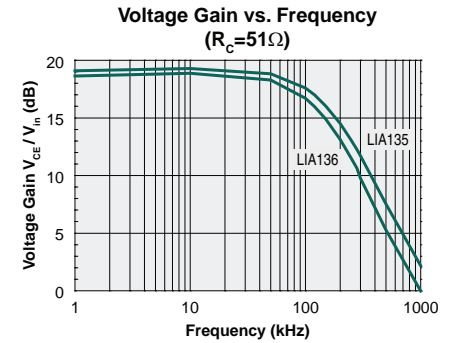
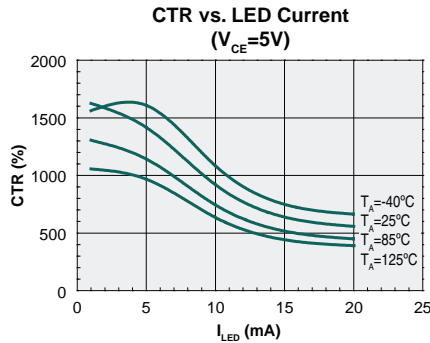
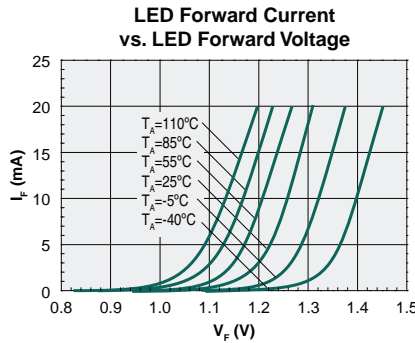
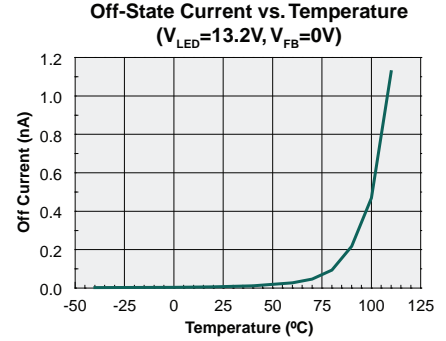
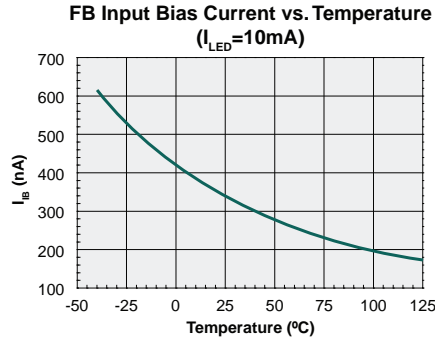
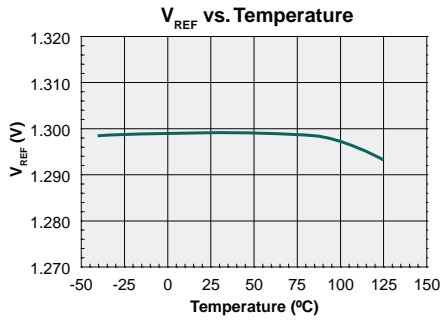

Figure 9: Operational Template



1.6 Performance Data



LIA135 - Dark Current vs. Temperature Measured At Pins 3&4 (V_{CE}=10V)

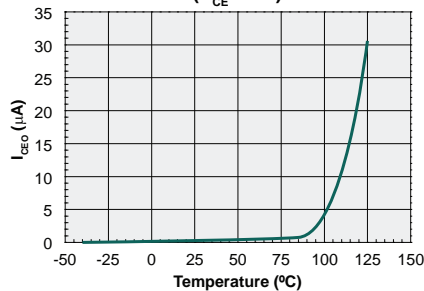

LIA136 - Dark Current vs. Temperature Measured At Pins 3&4, R_B=1MΩ (V_{CE}=10V)

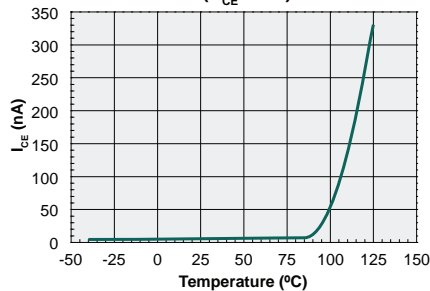

2. Functional Description

The LIA135 and LIA136 are optically isolated error amplifiers. Each comprises the three primary components necessary to implement feedback for an isolated power supply in a single package. These components are: an error amplifier; a voltage reference; and an optocoupler. The LIA135 and LIA136 are the functional equivalent of a 431 type precision shunt regulator and an optocoupler in the same package.

Understanding how the LIA135 and LIA136 function and are used is best understood by referencing the simplified application circuit shown in **Figure 10: Typical Isolated Power Supply Using an Optical Feedback Error Amplifier**. The function of the LIA135 / LIA136 is to sample the power supply output to be regulated, generate an error signal, and transmit the error signal across the isolation barrier to the power supply's control circuitry. Power for the input side circuits, consisting of an LED; a shunt regulator; and an error amplifier, is provided by the power supply's rectified secondary output (V_{OUT}) via the series current limiting resistor (R_{LED}) as shown in the application circuit.

Regulation of V_{OUT} is made possible by applying a scaled sample of its voltage to pin FB, the error amplifier's non-inverting input. The error amplifier compares this scaled voltage (V_{FB}) against an internal high accuracy reference voltage and generates an output which in turn sets the LED drive current.

As V_{OUT} increases, the error amplifier's input voltage V_{FB} will also increase. Ramping of V_{FB} beyond the internal reference voltage causes the error amplifier to generate the LED drive current (I_F) necessary to cause the optocoupler's NPN output transistor to conduct. Increasing the LED drive current results in an increase of the output transistor's collector current (I_C) which in turn decreases the voltage seen at the collector (V_C). This voltage is also commonly referred to as the Error Voltage (V_E).

Likewise, a reduction of V_{OUT} results in a lessening of I_F causing V_C to increase.

The power supply's control circuitry uses the error voltage presented by the optocoupler's output transistor to interpret the power needs of the secondary side load and to maintain regulation.

Figure 10: Typical Isolated Power Supply Using an Optical Feedback Error Amplifier

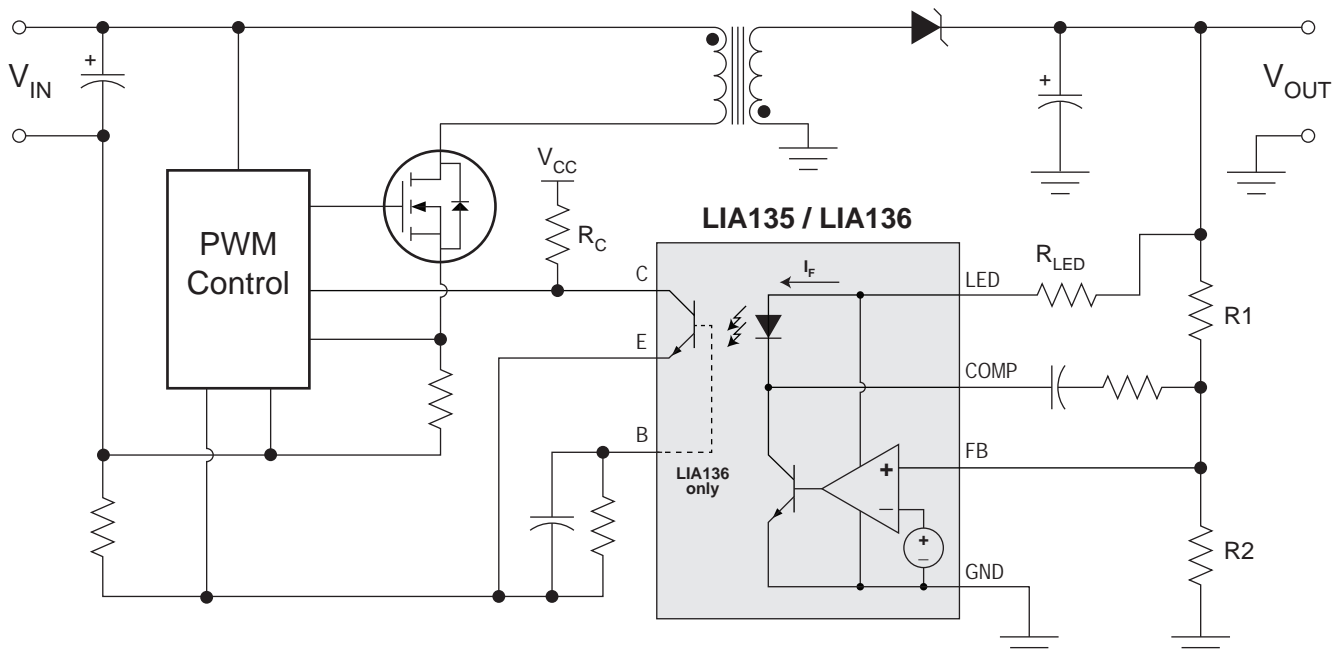

2.1 Input Side Biasing

Power for the LIA135 / LIA136 error amplifier, voltage reference, and optocoupler LED is applied to the LED pin through a current limiting resistor. Typically, this resistor's voltage source is V_{OUT} , the regulated power supply output. For very low voltage designs where V_{OUT} lacks sufficient headroom to bias the input circuitry, the resistor may be sourced from an auxiliary secondary winding on the transformer. When using the LIA135 / LIA136 this is an unlikely situation as these devices were designed specifically to be used for low voltage power supply applications. For all implementations, the minimum bias voltage at the LED pin is 1.6V.

There must be a current-limiting resistor (R_{LED}) in series with the LED pin to keep the current flow into the device and through the LED within their respective operating ranges for all expected supply output levels. Although the value of R_{LED} is determined in conjunction with the value of the phototransistor's pull-up resistor R_C , its minimum value is limited by the maximum allowed input current. [See Section 3. Design Examples on page 10.](#)

2.2 Supply Regulation

When connected as shown in the application circuit above and properly configured, the LIA135 / LIA136 will regulate V_{OUT} such that V_{FB} is equal to V_{REF} (1.299V). To achieve this, the values of the voltage divider resistors, R1 and R2, must be set in the following manner:

$$\frac{R1}{R2} = \left(\frac{V_{OUT}}{V_{REF}} \right) - 1$$

Because V_{OUT} regulation occurs when $V_{FB} = V_{REF}$ any change in bias current through R2 at the desired regulated voltage level will cause a regulation error. As shown in the Electrical Characteristics table the error amplifier input at pin FB has an input bias current (I_{IB}) specification that reduces the current into R2. (I_{IB} is always into pin FB). This error causes the regulated output voltage to increase which increases the current through R1 by an amount equal to I_{IB} , thereby restoring the current through R2 to its original value.

Reducing the V_{OUT} error created by the input bias current to less than 1% is accomplished by setting the

value of R1 using the following formula:

$$R1 < \frac{V_{OUT}}{50\mu A}$$

Where $50\mu A$ is $100 \times I_{IB(max)}$. This error can be reduced to less than 0.05% by setting the current to 1mA. i.e. $2000 \times I_{IB(max)}$

2.3 Compensation

Frequency response of the converter can be optimized for the specific application by placing a compensation network between the COMP and FB pins of the LIA135 / LIA136. In a typical system with a low-bandwidth requirement, only a $0.1\mu F$ capacitor should be needed. For designs with more critical bandwidth requirements, measurements of the loop response must be made and compensation adjusted as necessary.

2.4 Optocoupler Output Transistor

The output phototransistor of the LIA135 / LIA136 provides the isolated and amplified feedback signal that represents the output of the converter. Typically, the collector of the phototransistor will be pulled up by a reference voltage provided by the power supply control chip and the emitter will be grounded.

The base of the LIA135 output transistor is not externally accessible. For the LIA136 however, the base is brought out at pin 2 enabling the user to extend the capabilities of the device beyond those of the LIA135. Placing a resistor from the base to the emitter extends the operational temperature range by shunting base current around the base-emitter junction thereby reducing dark current at elevated temperatures. Immunity to large common mode transients (CMTI) is enhanced by placing a capacitor parallel to the base-emitter resistor. This shunts transient currents around the base-emitter junction rather than having them amplified by the transistor.

When using the LIA136 the base-emitter resistor must be populated, otherwise the open base lead will pick up atmospheric electromagnetic signals converting them into noise components.

2.5 N/C Pins

The N/C (No Connect) pins have no internal connection.

3. Design Examples

There are two basic designs, one with a discrete resistor at the optocoupler output whose value can be selected by the designer and the other with a resistor integrated within the power supply's PWM controller IC whose value is fixed. Common to both design flows is setting up the feedback from the power supply output to the error amplifier input.

For the discrete optocoupler output resistor solution, the design flow is determining the value of R_{LED} and then the optocoupler output resistor, R_C . When the optocoupler output resistor value is preselected and fixed, the design procedure is reversed. In both cases the value of these two resistors is dependent on the other.

3.1 Error Amplifier Input Configuration

Regulation of the power supply's output voltage is accomplished by configuring the voltage divider network consisting of R1 and R2 to apply a voltage equal to the Reference Voltage (V_{REF}) to FB, the feedback amplifier's input, when the supply's output is at it's desired potential.

For this example, the nominal value of the power supply output voltage is 1.8V. Because the LIA135 and LIA136 operate with an input voltage of 1.6V there is no requirement to provide an auxiliary transformer winding to bias the optical feedback circuitry.

To reduce regulation error caused by loss of bias current into pin FB, the current through R1 must be set much greater than I_{IB} , the leakage current into pin FB. Setting $R1 = 1k\Omega$, a convenient common value will ensure the current through R1 will be much greater than I_{IB} .

With $R1 = 1k\Omega$, and setting $R2 = 2.61k\Omega$ will fix the nominal supply output voltage to 1.797V, just slightly below the target value of 1.8V.

3.2 Discrete Optocoupler Output Resistor

The value of the optocoupler's collector pull-up resistor (R_C) and of the LED current-limiting resistor (R_{LED}) must be determined together with respect to the input voltage range of the power supply's PWM device. Additionally, the operational range and performance

characteristics of the LIA135 and LIA136 must be taken into account.

As an example, consider first that the minimum CTR of the LIA135 / LIA136 is 500%. Selection of R_{LED} to set the minimum current through the LED (I_F) to 1mA when the converter output (V_{OUT}) is at it's nominal value of 1.797V is as follows:

$$R_{LED} \leq \frac{V_{OUT} - V_{LED(min)}}{I_F + I_{Q(max)}}$$

$$R_{LED} \leq \frac{1.797V - 1.6V}{1mA + 100\mu A} = \frac{0.197V}{1.1mA} = 179.09\Omega$$

Using the nearest standard value that satisfies the relationship above sets $R_{LED} = 178\Omega$. Rearranging the terms and calculating for the LED current gives $I_F = 1.00674mA$. A minimum of 5.0337mA will flow through the collector pull-up resistor. If the collector is pulled up to 12V and the PWM has an internal reference voltage of 5V, then the minimum pull-up resistor value is:

$$R_C \geq \frac{12V - 5V}{5.0337mA} = 1.391k\Omega$$

Setting $R_C = 1.40k\Omega$ (E96 standard value) changes the collector voltage under these conditions from the ideal 5V to 4.953V.

The value of R_{LED} must never allow more than 20mA of current to flow into the LED pin. Assuming a V_{OUT} tolerance of 10% then:

$$R_{LED} \geq \frac{1.98V - 1.6V}{20mA} = 19\Omega$$

The value $R_{LED} = 178\Omega$ selected above satisfies the minimum value of the LED resistor.

3.3 Integrated Optocoupler Output Resistor

Many times the collector pull-up resistor is integrated into the PWM controller IC and may be a current source rather than a resistive component.

The design methodology is similar to the external discrete pull-up resistor design but the LED current limiting resistor must be calculated starting from the pull-up at the optocoupler output transistor's collector.

4. Manufacturing Information

4.1 Moisture Sensitivity



All plastic encapsulated semiconductor packages are susceptible to moisture ingress. IXYS Integrated Circuits Division classified all of its plastic encapsulated devices for moisture sensitivity according to the latest version of the joint industry standard, **IPC/JEDEC J-STD-020**, in force at the time of product evaluation. We test all of our products to the maximum conditions set forth in the standard, and guarantee proper operation of our devices when handled according to the limitations and information in that standard as well as to any limitations set forth in the information or standards referenced below.

Failure to adhere to the warnings or limitations as established by the listed specifications could result in reduced product performance, reduction of operable life, and/or reduction of overall reliability.

This product carries a **Moisture Sensitivity Level (MSL) rating** as shown below, and should be handled according to the requirements of the latest version of the joint industry standard **IPC/JEDEC J-STD-033**.

| Device | Moisture Sensitivity Level (MSL) Rating |
|------------------------------|---|
| LIA135 / LIA136 All versions | MSL 1 |

4.2 ESD Sensitivity



This product is **ESD Sensitive**, and should be handled according to the industry standard **JESD-625**.

4.3 Soldering Profile

Provided in the table below is the Classification Temperature (T_C) of this product and the maximum dwell time the body temperature of this device may be above ($T_C - 5$)°C. The classification temperature sets the Maximum Body Temperature allowed for this device during lead-free reflow processes.

| Device | Maximum Body Temperature (T_C) x Time | Maximum Reflow Cycles |
|------------------------------|---|-----------------------|
| LIA135 / LIA136 All versions | 250°C for 30 seconds | 3 |

4.4 Board Wash

IXYS Integrated Circuits Division recommends the use of no-clean flux formulations. Board washing to reduce or remove flux residue following the solder reflow process is acceptable provided proper precautions are taken to prevent damage to the device. These precautions include but are not limited to: using a low pressure wash and providing a follow up bake cycle sufficient to remove any moisture trapped within the device due to the washing process. Due to the variability of the wash parameters used to clean the board, determination of the bake temperature and duration necessary to remove the moisture trapped within the package is the responsibility of the user (assembler). Cleaning or drying methods that employ ultrasonic energy may damage the device and should not be used. Additionally, the device must not be exposed to flux or solvents that are Chlorine- or Fluorine-based.



4.5 Mechanical Dimensions

4.5.1 LIA135 & LIA136 DIP Package

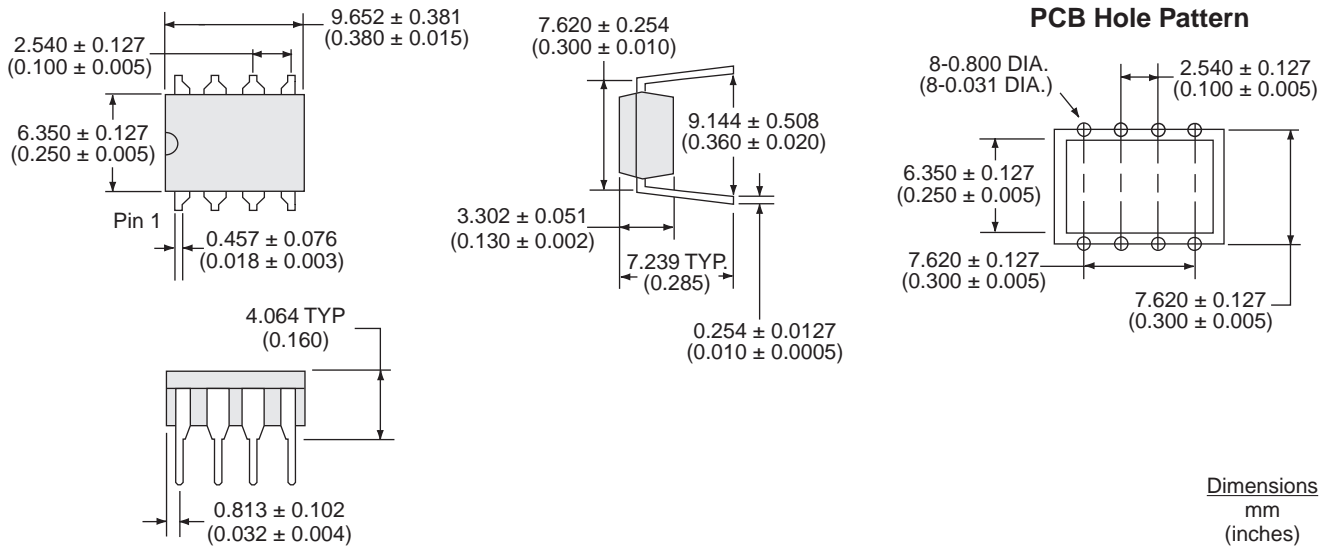

4.5.2 LIA135S & LIA136S SMT Package

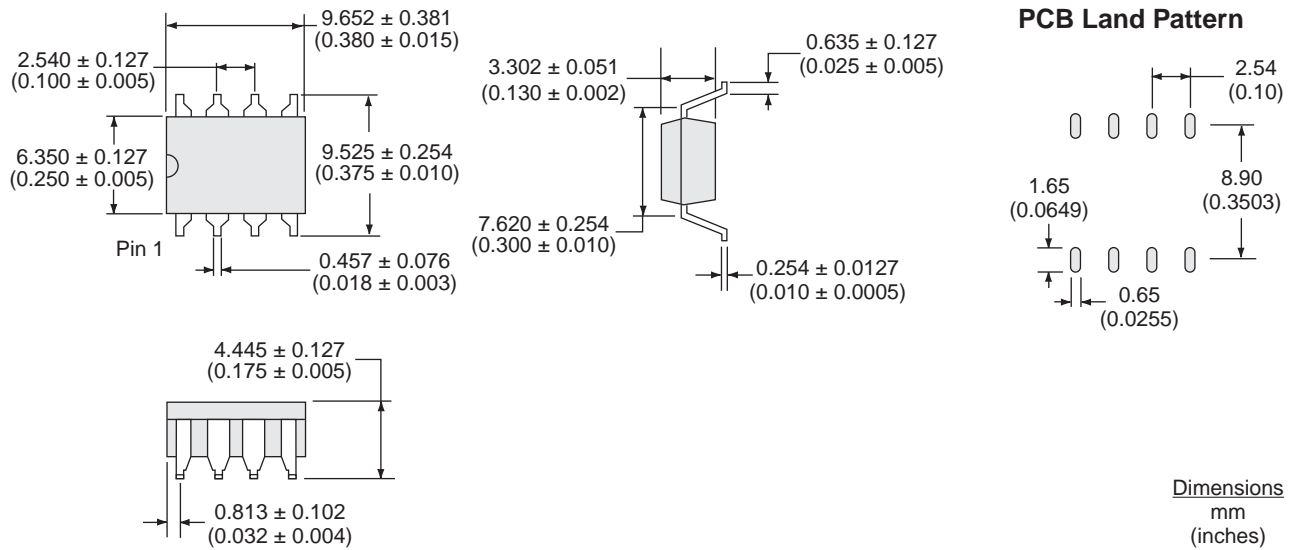

4.5.3 LIA135STR & LIA136STR SMT Tape & Reel

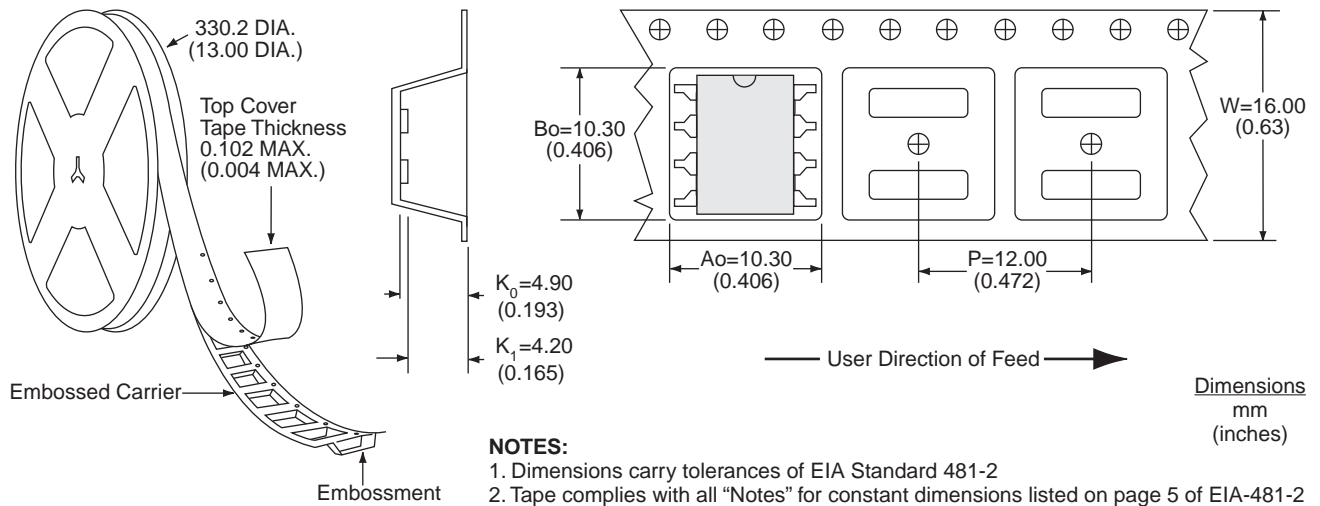

For additional information please visit www.ixysic.com

IXYS Integrated Circuits Division makes no representations or warranties with respect to the accuracy or completeness of the contents of this publication and reserves the right to make changes to specifications and product descriptions at any time without notice. Neither circuit patent licenses or indemnity are expressed or implied. Except as set forth in IXYS Integrated Circuits Division's Standard Terms and Conditions of Sale, IXYS Integrated Circuits Division assumes no liability whatsoever, and disclaims any express or implied warranty relating to its products, including, but not limited to, the implied warranty of merchantability, fitness for a particular purpose, or infringement of any intellectual property right.

The products described in this document are not designed, intended, authorized, or warranted for use as components in systems intended for surgical implant into the body, or in other applications intended to support or sustain life, or where malfunction of IXYS Integrated Circuits Division's product may result in direct physical harm, injury, or death to a person or severe property or environmental damage. IXYS Integrated Circuits Division reserves the right to discontinue or make changes to its products at any time without notice.

Specifications: DS-LIA135 / LIA136-R01
© Copyright 2015, IXYS Integrated Circuits Division
All rights reserved. Printed in USA.
12/11/2015

X-ON Electronics

Largest Supplier of Electrical and Electronic Components

Click to view similar products for [Optically Isolated Amplifiers](#) category:

Click to view products by [IXYS](#) manufacturer:

Other Similar products are found below :

[LIA130S](#) [ACPL-C79A-500E](#) [ACPL-C797-500E](#) [TLP7930\(D4-TP1,F](#) [TLP7920\(D4-A,F](#) [LIA130](#) [ACPL-C790-500E](#) [ACPL-782T-500E](#)
[ACPL-790B-000E](#) [ACPL-C78A-000E](#) [ACPL-C87BT-500E](#) [HCPL-7510-300E](#) [HCPL-7520-300E](#) [HCPL-7520-500E](#) [HCPL-788J-500E](#)
[ACPL-782T-300E](#) [ACPL-7970-000E](#) [ACPL-C784-500E](#) [ACPL-C79B-500E](#) [ACPL-C79A-000E](#) [ACPL-C87AT-000E](#) [ACPL-C87B-500E](#)
[HCPL-7520-000E](#) [HCPL-7800-000E](#) [HCPL-7800A-000E](#) [HCPL-7840-000E](#) [HCPL-7800-300E](#) [HCPL-7840-300E](#) [HCPL-7800A-500E](#)
[HCPL-7840-500E](#) [HCPL-7800-500E](#) [ACPL-7970-500E](#) [HCPL-788J-000E](#) [H11L2](#) [H11L1SM](#) [ACPL-C87H-500E](#) [TLP7920\(D4,F](#)
[TLP7920\(F](#) [TLP7820\(D4BLF4,E](#) [ACPL-C780-000E](#) [ACPL-7900-300E](#) [ACPL-C78A-500E](#) [TLP7820\(D4ALF4,E](#)