

XPT IGBT Module

$V_{CES} = 1200\text{ V}$
 $I_{C25} = 360\text{ A}$
 $V_{CE(sat)} = 1.8\text{ V}$

Boost chopper + free wheeling Diodes + NTC

Part number
 MIXA225RF1200TSF

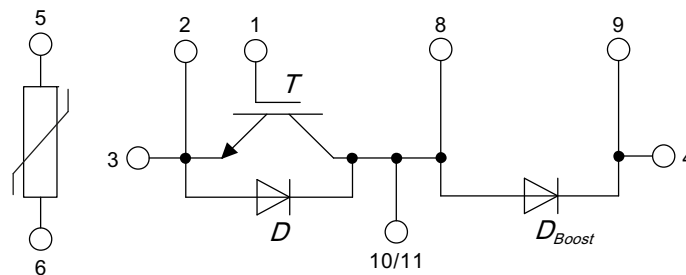
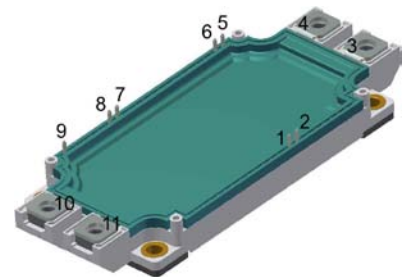

Features / Advantages:

- High level of integration - only one power semiconductor module required for the whole drive
- Rugged XPT design (Xtreme light Punch Through) results in:
 - short circuit rated for 10 μ sec.
 - very low gate charge
 - low EMI
 - square RBSOA @ 3x Ic
- Thin wafer technology combined with the XPT design results in a competitive low $V_{CE(sat)}$
- Temperature sense included
- SONIC™ diode
 - fast and soft reverse recovery
 - low operating forward voltage

Applications:

- Brake for AC motor drives
- Boost chopper
- Switch reluctance drives

Package: SimBus F

- Industry standard outline
- RoHS compliant
- Soldering pins for PCB mounting
- Height: 17 mm
- Base plate:
 - Copper internally DCB isolated
- Advanced power cycling

IGBT <i>T</i>				Ratings			
Symbol	Definitions	Conditions	min.	typ.	max.	Unit	
V_{CES}	collector emitter voltage	$T_{VJ} = 25^{\circ}\text{C to } 125^{\circ}\text{C}$			1200	V	
V_{GES}	max. DC gate voltage				± 20	V	
V_{GEM}	max. transient gate emitter voltage				± 30	V	
I_{C25}	collector current	$T_C = 25^{\circ}\text{C}$			360	A	
I_{C80}		$T_C = 80^{\circ}\text{C}$			250	A	
P_{tot}	total power dissipation	$T_C = 25^{\circ}\text{C}$			1100	W	
$V_{CE(sat)}$	collector emitter saturation voltage	$I_C = 225\text{ A}; V_{GE} = 15\text{ V}$		1.8	2.1	V	
				2.1		V	
$V_{GE(th)}$	gate emitter threshold voltage	$I_C = 9\text{ mA}; V_{GE} = V_{CE}$	5.4		6.5	V	
I_{CES}	collector emitter leakage current	$V_{CE} = V_{CES}; V_{GE} = 0\text{ V}$		0.3	0.3	mA	
				0.3		mA	
I_{GES}	gate emitter leakage current	$V_{GE} = \pm 20\text{ V}; V_{CE} = 0\text{ V}$			1.5	μA	
$Q_{G(on)}$	total gate charge	$V_{CE} = 600\text{ V}; V_{GE} = 15\text{ V}; I_C = 225\text{ A}$		690		nC	
$t_{d(on)}$	turn-on delay time	inductive load $V_{CE} = 600\text{ V}; I_C = 225\text{ A}$ $V_{GE} = \pm 15\text{ V}; R_G = 3.3\ \Omega$		60		ns	
t_r	current rise time		$T_{VJ} = 125^{\circ}\text{C}$		70		ns
$t_{d(off)}$	turn-off delay time				280		ns
t_f	current fall time				310		ns
E_{on}	turn-on energy per pulse				20		mJ
E_{off}	turn-off energy per pulse				27		mJ
RBSOA	reverse bias safe operating area	$V_{GE} = \pm 15\text{ V}; R_G = 3.3\ \Omega$					
I_{CM}		$V_{CEmax} = 1200\text{ V}$			500	A	
SCSOA	short circuit safe operating area	$V_{CEmax} = 1200\text{ V}$					
t_{SC}	short circuit duration	$V_{CE} = 900\text{ V}; V_{GE} = \pm 15\text{ V};$			10	μs	
I_{SC}	short circuit current	$R_G = 3.3\ \Omega; \text{non-repetitive}$		900		A	
R_{thJC}	thermal resistance junction to case				0.115	K/W	
R_{thCH}	thermal resistance case to heatsink			0.045		K/W	
Diode D_{Boost}							
V_{RRM}	max. repetitive reverse voltage				1200	V	
I_{F25}	forward current				265	A	
I_{F80}					185	A	
V_F	forward voltage	$I_F = 225\text{ A}; V_{GE} = 0\text{ V}$		1.80	2.10	V	
				1.70		V	
I_R	reverse current	$V_R = V_{RRM}$		0.3	0.3	mA	
				0.3		mA	
Q_{rr}	reverse recovery charge	$V_R = 600\text{ V}$ $-di_F/dt = 3300\text{ A}/\mu\text{s}$ $I_F = 225\text{ A}; V_{GE} = 0\text{ V}$		32		μC	
I_{RM}	max. reverse recovery current		$T_{VJ} = 125^{\circ}\text{C}$		250		A
t_{rr}	reverse recovery time				340		ns
E_{rec}	reverse recovery energy				11.7		mJ
R_{thJC}	thermal resistance junction to case				0.145	K/W	
R_{thCH}	thermal resistance case to heatsink			0.05		K/W	

Diode D				Ratings			
Symbol	Definitions	Conditions	min.	typ.	max.	Unit	
V_{RRM}	max. repetitive reverse voltage				1200	V	
I_{F25}	forward current				65	A	
I_{F80}					45	A	
V_F	forward voltage	$I_F = 60 \text{ A}; V_{GE} = 0 \text{ V}$		2.0	2.2	V	
				2.0		V	
I_R	reverse current * not applicable, see Ices value of IGBT T	$V_R = V_{RRM}$		*	*	mA mA	
R_{thJC}	thermal resistance junction to case				0.5	K/W	
R_{thCH}	thermal resistance case to heatsink			0.2		K/W	

Package SimBus F				Ratings			
Symbol	Definitions	Conditions	min.	typ.	max.	Unit	
I_{RMS}	RMS current	per terminal				A	
T_{stg}	storage temperature		-40		125	°C	
T_{VJM}	virtual junction temperature		-40		150	°C	
Weight				350		g	
					3400	V~	
			$I_{ISOL} \leq 1 \text{ mA}; 50/60 \text{ Hz}$				
M_D	mounting torque (M5)		3		6	Nm	
M_T	terminal torque (M6)		3		6	Nm	
$d_{Spp/App}$	creepage distance on surface / striking distance through air	terminal to terminal	12.7			mm	
$d_{Spb/Apb}$		terminal to backside	10.0			mm	
V_{ISOL}	isolation voltage	$t = 1 \text{ second}$	3000			V	
		$t = 1 \text{ minute}$	2500			V	
		50/60 Hz, RMS, $I_{ISOL} \leq 1 \text{ mA}$					
$R_{term-chip}$	resistance terminal to chip	$V = V_{CEsat} + 2x R_{term-chip} \cdot I_C$ resp. $V = V_F + 2x R \cdot I_F$		0.65		mΩ	

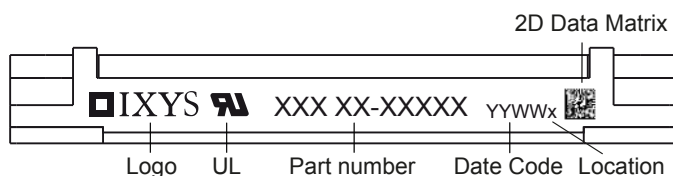

Part number

M = Module
 I = IGBT
 X = XPT
 A = standard
 225 = Current Rating [A]
 RF = Boost / brake chopper + free wheeling diode
 1200 = Reverse Voltage [V]
 T = NTC
 EH = E3-Pack

Ordering	Part Name	Marking on Product	Delivering Mode	Base Qty	Ordering Code
Standard	MIXA225RF1200TSF	MIXA225RF1200TSF	Box	3	511581

Temperature Sensor NTC			Ratings			
Symbol	Definitions	Conditions	min.	typ.	max.	Unit
R_{25}	resistance	$T_C = 25^\circ\text{C}$	4.75	5.0	5.25	kΩ
$B_{25/50}$	temperature coefficient			3375		K

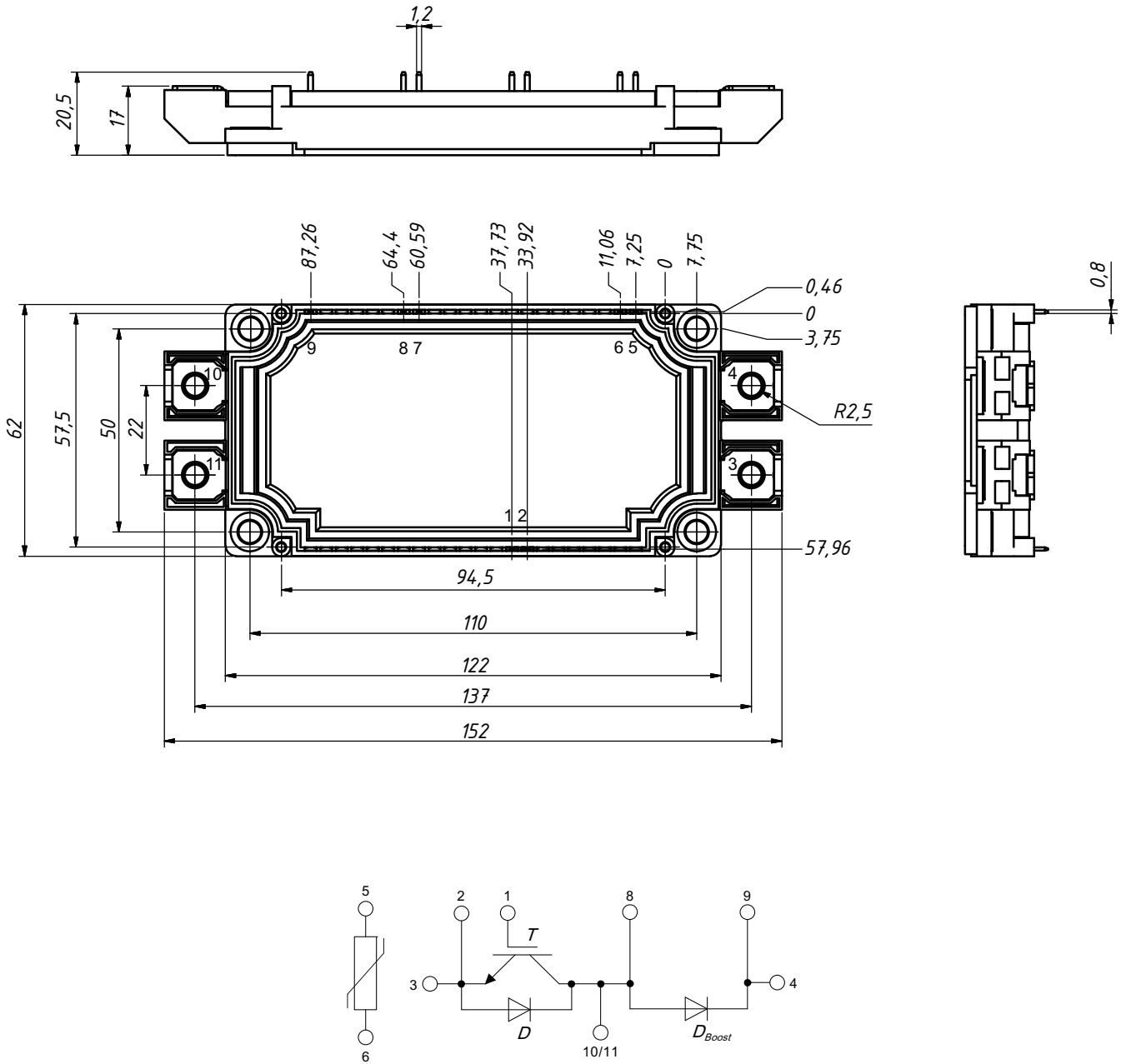
Outlines SimBus F



X-ON Electronics

Largest Supplier of Electrical and Electronic Components

Click to view similar products for [IGBT Modules category](#):

Click to view products by [IXYS manufacturer](#):

Other Similar products are found below :

[F3L100R07W2E3_B11](#) [F3L15R12W2H3_B27](#) [F3L400R07ME4_B22](#) [F3L400R12PT4_B26](#) [F4-100R12KS4](#) [F4-50R07W2H3_B51](#) [F4-75R12KS4_B11](#) [FB15R06W1E3](#) [FB20R06W1E3_B11](#) [FD1000R33HE3-K](#) [FD300R06KE3](#) [FD300R12KE3](#) [FD300R12KS4_B5](#) [FD400R12KE3](#) [FD400R33KF2C-K](#) [FD401R17KF6C_B2](#) [FD-DF80R12W1H3_B52](#) [FF100R12KS4](#) [FF1200R17KE3_B2](#) [FF150R12KE3G](#) [FF200R06KE3](#) [FF200R06YE3](#) [FF200R12KT3](#) [FF200R12KT3_E](#) [FF200R12KT4](#) [FF200R17KE3](#) [FF300R06KE3_B2](#) [FF300R12KE4_E](#) [FF300R12KS4HOSA1](#) [FF300R12ME4_B11](#) [FF300R12MS4](#) [FF300R17ME4](#) [FF450R12ME4P](#) [FF450R17IE4](#) [FF600R12IE4V](#) [FF600R12IP4V](#) [FF800R17KP4_B2](#) [FF900R12IE4V](#) [MIXA30W1200TED](#) [MIXA450PF1200TSF](#) [FP06R12W1T4_B3](#) [FP100R07N3E4](#) [FP100R07N3E4_B11](#) [FP10R06W1E3_B11](#) [FP10R12W1T4_B11](#) [FP10R12YT3](#) [FP10R12YT3_B4](#) [FP150R07N3E4](#) [FP15R12KT3](#) [FP15R12W2T4](#)