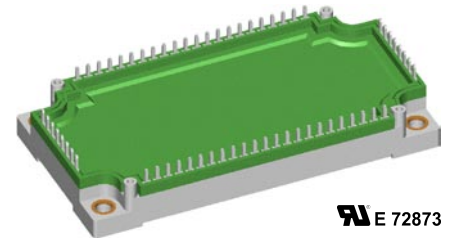
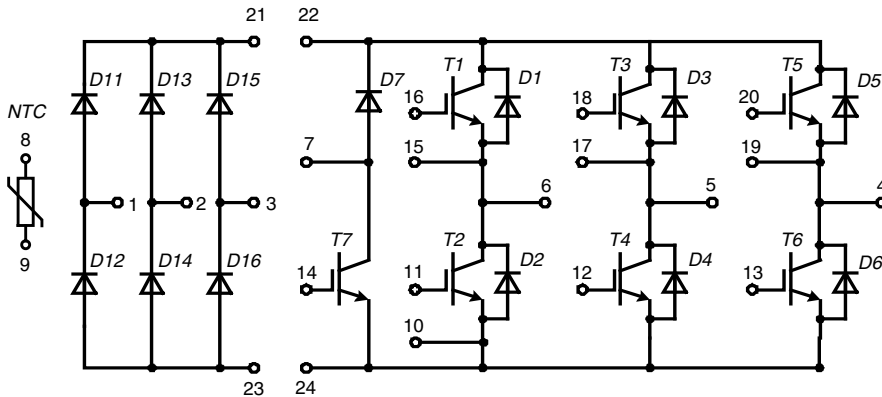


Converter - Brake - Inverter Module (CBI3) with Trench IGBT technology



E 72873

Three Phase Rectifier	Brake Chopper	Three Phase Inverter
$V_{RRM} = 1600 \text{ V}$	$V_{CES} = 1200 \text{ V}$	$V_{CES} = 1200 \text{ V}$
$I_{FAVM} = 50 \text{ A}$	$I_{C25} = 55 \text{ A}$	$I_{C25} = 80 \text{ A}$
$I_{FSM} = 850 \text{ A}$	$V_{CE(sat)} = 1.7 \text{ V}$	$V_{CE(sat)} = 1.7 \text{ V}$

Input Rectifier Bridge D11 - D16			
Symbol	Conditions	Maximum Ratings	
V_{RRM}		1600	V
I_{FAV}	$T_C = 80^\circ\text{C}$; sine 180°	50	A
I_{DAVM}	$T_C = 80^\circ\text{C}$; rectangular; $d = 1/3$; bridge	140	A
I_{FSM}	$T_C = 25^\circ\text{C}$; $t = 10 \text{ ms}$; sine 50 Hz	850	A
P_{tot}	$T_C = 25^\circ\text{C}$	125	W

Symbol	Conditions	Characteristic Values			
		min.	typ.	max.	
$(T_{VJ} = 25^\circ\text{C}, \text{ unless otherwise specified})$					
V_F	$I_F = 50 \text{ A}$;	$T_{VJ} = 25^\circ\text{C}$	1.15	1.3	V
		$T_{VJ} = 125^\circ\text{C}$		1.05	V
I_R	$V_R = V_{RRM}$;	$T_{VJ} = 25^\circ\text{C}$		0.05	mA
		$T_{VJ} = 125^\circ\text{C}$	0.8		mA
R_{thJC}	(per diode)			1.0	K/W

Application: AC motor drives with

- Input from single or three phase grid
- Three phase synchronous or asynchronous motor
- electric braking operation

Features

- High level of integration - only one power semiconductor module required for the whole drive
- IGBT technology with low saturation voltage, low switching losses and tail current, high RBSOA and short circuit ruggedness
- Epitaxial free wheeling diodes with Hiperfast and soft reverse recovery
- Industry standard package with insulated copper base plate and soldering pins for PCB mounting
- Temperature sense included

Output Inverter T1 - T6			
Symbol	Conditions	Maximum Ratings	
V_{CES}	$T_{VJ} = 25^{\circ}\text{C}$ to 150°C	1200	V
V_{GES}	Continuous	± 20	V
I_{C25}	$T_C = 25^{\circ}\text{C}$	80	A
I_{C80}	$T_C = 80^{\circ}\text{C}$	50	A
I_{CM}	$T_C = 80^{\circ}\text{C}$; $t_p = 1$ ms	100	A
P_{tot}	$T_C = 25^{\circ}\text{C}$	270	W

Symbol	Conditions	Characteristic Values			
		(T _{VJ} = 25°C, unless otherwise specified)			
		min.	typ.	max.	
$V_{CE(sat)}$	$I_C = 50$ A; $V_{GE} = 15$ V				$T_{VJ} = 25^{\circ}\text{C}$
					$T_{VJ} = 125^{\circ}\text{C}$
$V_{GE(th)}$	$I_C = 2$ mA; $V_{GE} = V_{CE}$	5	5.8	6.5	V
I_{CES}	$V_{CE} = V_{CES}$; $V_{GE} = 0$ V				$T_{VJ} = 25^{\circ}\text{C}$
					$T_{VJ} = 125^{\circ}\text{C}$
I_{GES}	$V_{CE} = 0$ V; $V_{GE} = \pm 20$ V			400	nA
C_{ies}	$V_{CE} = 25$ V; $V_{GE} = 0$ V; $f = 1$ MHz		3.5		nF
Q_{Gon}	$V_{CE} = 600$ V; $V_{GE} = 15$ V; $I_C = 50$ A		470		nC
$t_{d(on)}$ t_r $t_{d(off)}$ t_f E_{on} E_{off}	Inductive load, $T_{VJ} = 125^{\circ}\text{C}$ $V_{CE} = 600$ V; $I_C = 50$ A $V_{GE} = \pm 15$ V; $R_G = 18$ Ω				90
					50
					520
					90
					5
					6.5
RBSOA	$I_C = I_{CM}$; $V_{GE} = 15$ V $R_G = 18$ Ω ; $T_{VJ} = 125^{\circ}\text{C}$			$V_{CEK} \leq V_{CES} - L_S di/dt$	V
t_{SC} (SCSOA)	$V_{CE} = 720$ V; $V_{GE} = \pm 15$ V; $R_G = 18$ Ω $t_p \leq 10$ μs ; non-repetitive; $T_{VJ} = 125^{\circ}\text{C}$		200		A
R_{thJC}				0.46	K/W

Output Inverter D1 - D6					
Symbol	Conditions	Maximum Ratings			
I_{F25}	$T_C = 25^{\circ}\text{C}$	100	A		
I_{F80}	$T_C = 80^{\circ}\text{C}$	50	A		
Symbol	Conditions	Characteristic Values			
		min.	typ.	max.	
V_F	$I_F = 50$ A;				$T_{VJ} = 25^{\circ}\text{C}$
					$T_{VJ} = 125^{\circ}\text{C}$
I_{RM} Q_{rr} t_{rr} E_{rec}	$I_F = 60$ A; $di_F/dt = -1200$ A/ μs ; $T_{VJ} = 125^{\circ}\text{C}$; $V_R = 600$ V; $V_{GE} = 0$ V				90
					10
					160
					4
R_{thJC}	(per diode)			0.65	K/W

Brake Chopper T7			
Symbol	Conditions	Maximum Ratings	
V_{CES}	$T_{VJ} = 25^{\circ}\text{C}$ to 150°C	1200	V
V_{GES}	Continuous	± 20	V
I_{C25}	$T_C = 25^{\circ}\text{C}$	55	A
I_{C80}	$T_C = 80^{\circ}\text{C}$	35	A
I_{CM}	$T_C = 80^{\circ}\text{C}$; $t_p = 1$ ms	70	A
P_{tot}	$T_C = 25^{\circ}\text{C}$	200	W

Symbol	Conditions	Characteristic Values				
		$(T_{VJ} = 25^{\circ}\text{C}, \text{ unless otherwise specified})$				
		min.	typ.	max.		
$V_{CE(sat)}$	$I_C = 35$ A; $V_{GE} = 15$ V			1.7	2.15	V
				$T_{VJ} = 25^{\circ}\text{C}$	2.0	
$V_{GE(th)}$	$I_C = 1.5$ mA; $V_{GE} = V_{CE}$	5	5.8	6.5	V	
I_{CES}	$V_{CE} = V_{CES}$; $V_{GE} = 0$ V				0.25	mA
				$T_{VJ} = 25^{\circ}\text{C}$	0.3	
I_{GES}	$V_{CE} = 0$ V; $V_{GE} = \pm 20$ V			400	nA	
C_{ies}	$V_{CE} = 25$ V; $V_{GE} = 0$ V; $f = 1$ MHz		2.5		nF	
Q_{Gon}	$V_{CE} = 600$ V; $V_{GE} = 15$ V; $I_C = 35$ A		330		nC	
$t_{d(on)}$	Inductive load, $T_{VJ} = 125^{\circ}\text{C}$ $V_{CE} = 600$ V; $I_C = 35$ A $V_{GE} = \pm 15$ V; $R_G = 27$ Ω			90		ns
t_r				50		ns
$t_{d(off)}$				520		ns
t_f				90		ns
E_{off}				4.8		mJ
RBSOA	$I_C = I_{CM}$; $V_{GE} = 15$ V $R_G = 27$ Ω ; $T_{VJ} = 125^{\circ}\text{C}$		$V_{CEK} \leq V_{CES} - L_S di/dt$			V
t_{SC} (SCSOA)	$V_{CE} = 720$ V; $V_{GE} = \pm 15$ V; $R_G = 27$ Ω $t_p \leq 10$ μs ; non-repetitive; $T_{VJ} = 125^{\circ}\text{C}$		140			A
R_{thJC}				0.62		K/W

Brake Chopper D7			
Symbol	Conditions	Maximum Ratings	
V_{RRM}	$T_{VJ} = 25^{\circ}\text{C}$ to 150°C	1200	V
I_{F25}	$T_C = 25^{\circ}\text{C}$	48	A
I_{F80}	$T_C = 80^{\circ}\text{C}$	30	A

Symbol	Conditions	Characteristic Values				
		min.	typ.	max.		
V_F	$I_F = 35$ A;			2.5	3.3	V
				$T_{VJ} = 25^{\circ}\text{C}$	2.0	
I_R	$V_R = V_{RRM}$;				0.25	mA
				$T_{VJ} = 25^{\circ}\text{C}$	0.5	
R_{thJC}	(per diode)			1.2		K/W

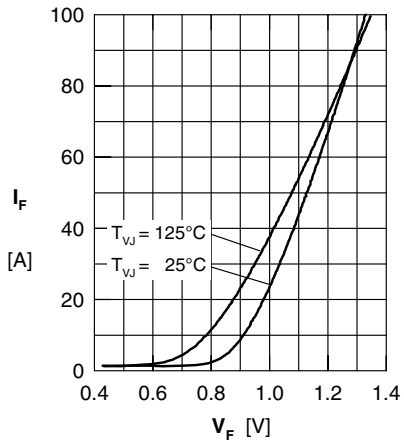
Input Rectifier Bridge D11 - D16


Fig. 1 Typ. forward current vs. voltage drop per diode

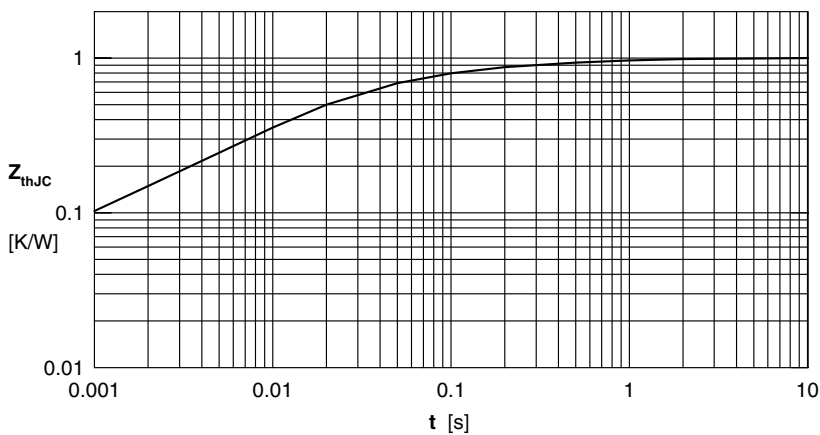


Fig. 2 Transient thermal impedance junction to case

Output Inverter T1 - T6 / D1 - D6

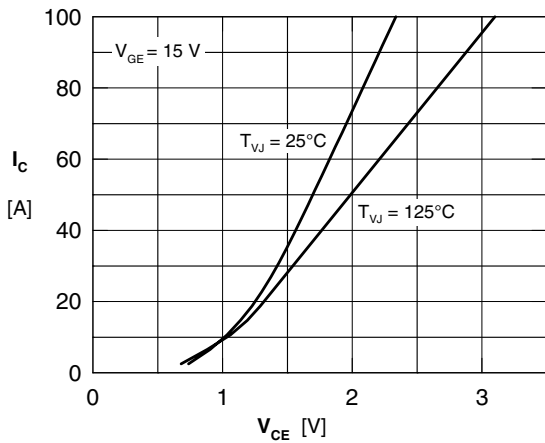


Fig. 3 Typical output characteristic

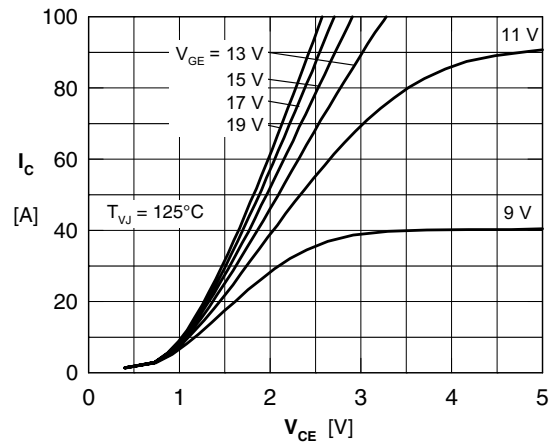


Fig. 4 Typical output characteristic

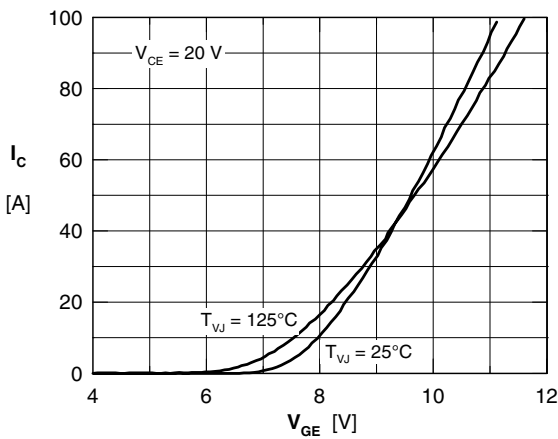


Fig. 5 Typical transfer characteristic

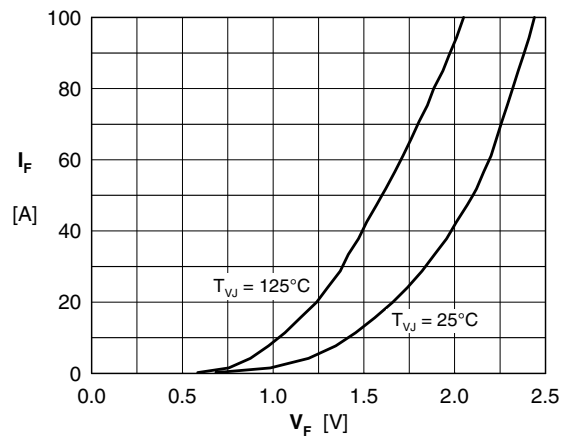


Fig. 6 Typical forward characteristic of free wheeling diode

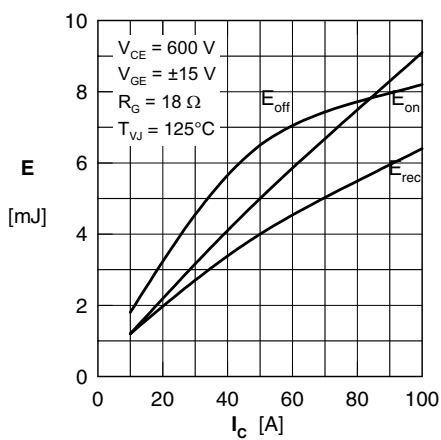


Fig. 7 Typ. switching losses vs. collector current

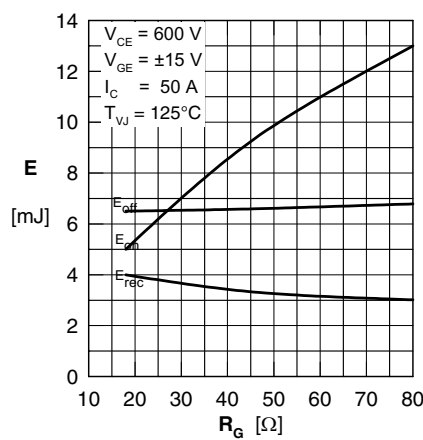


Fig. 8 Typ. switching losses vs. gate resistance

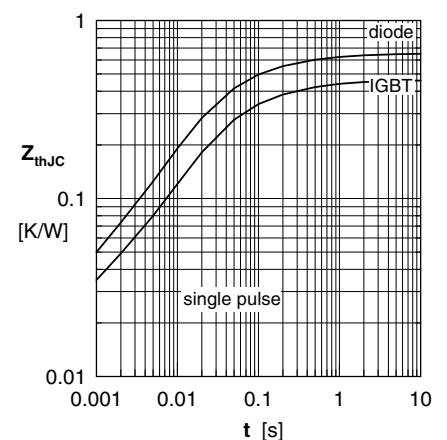


Fig. 9 Transient thermal impedance

Brake Chopper T7 / D7

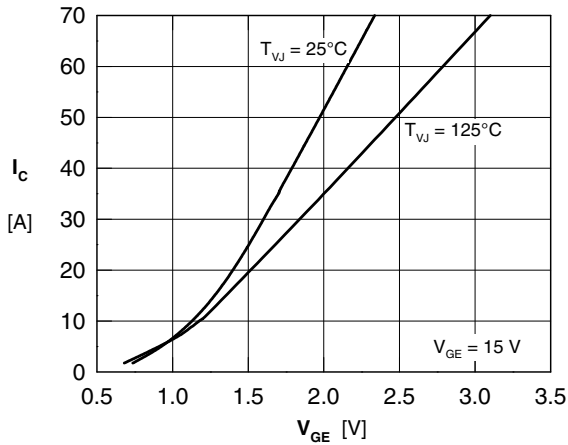


Fig. 10 Typical output characteristics

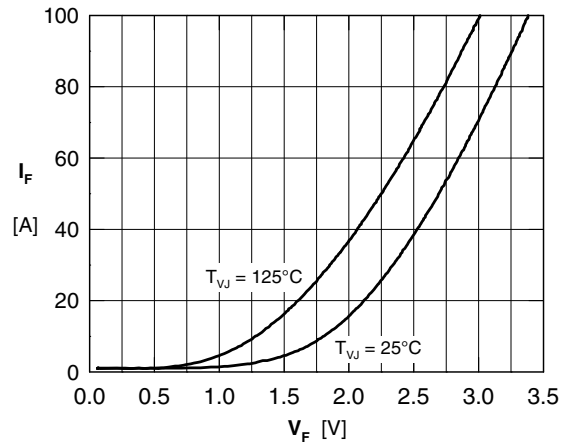


Fig. 11 Typical forward characteristics of free wheeling diode

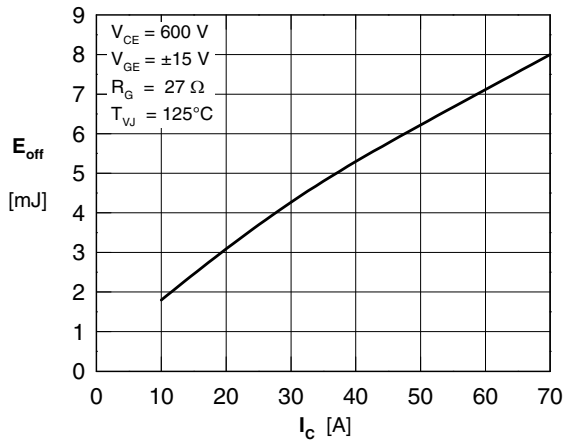


Fig. 12 Typ. turn off energy vs. collector current

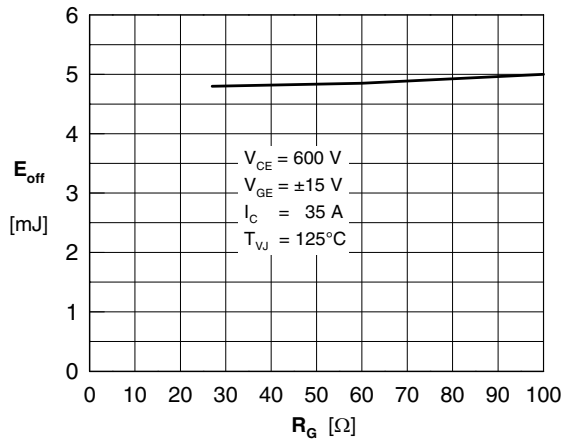


Fig. 13 Typ. turn off energy versus gate

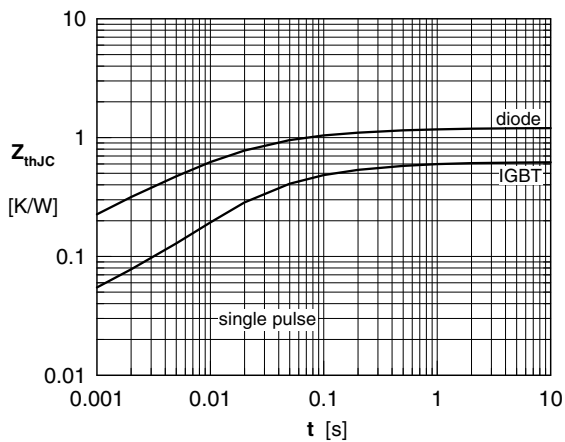


Fig. 14 Transient thermal impedance

Temperature Sensor NTC

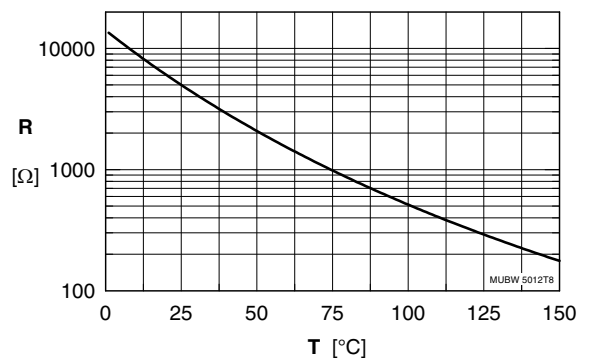


Fig. 15 Typ. thermistor resistance versus temperature

X-ON Electronics

Largest Supplier of Electrical and Electronic Components

Click to view similar products for [Discrete Semiconductor Modules](#) category:

Click to view products by [IXYS](#) manufacturer:

Other Similar products are found below :

[M252511FV](#) [DD260N12K-A](#) [DD380N16A](#) [DD89N1600K-A](#) [APT2X21DC60J](#) [APT58M80J](#) [B522F-2-YEC](#) [MSTC90-16](#) [25.163.0653.1](#)
[25.163.2453.0](#) [25.163.4253.0](#) [25.190.2053.0](#) [25.194.3453.0](#) [25.320.4853.1](#) [25.320.5253.1](#) [25.326.3253.1](#) [25.326.3553.1](#) [25.330.1653.1](#)
[25.330.4753.1](#) [25.330.5253.1](#) [25.334.3253.1](#) [25.334.3353.1](#) [25.350.2053.0](#) [25.352.4753.1](#) [25.522.3253.0](#) [T483C](#) [T484C](#) [T485F](#) [T485H](#)
[T512F-YEB](#) [T513F](#) [T514F](#) [T554](#) [T612FSE](#) [25.161.3453.0](#) [25.179.2253.0](#) [25.194.3253.0](#) [25.325.1253.1](#) [25.326.4253.1](#) [25.330.0953.1](#)
[25.332.4353.1](#) [25.350.1653.0](#) [25.350.2453.0](#) [25.352.1453.0](#) [25.352.1653.0](#) [25.352.2453.0](#) [25.352.5453.1](#) [25.522.3353.0](#) [25.602.4053.0](#)
[25.640.5053.0](#)