

# JBC

[www.jbctools.com](http://www.jbctools.com)

## INSTRUCTION MANUAL



### ALU

Auto-Feed Soldering Control Unit

This manual corresponds to the following references:

- **ALU-9A** (100V)
- **ALU-1A** (120V)
- **ALU-2A** (230V)

## Packing List

The following items are included:



**ALU Control Unit** ..... 1 unit



**Power Cord** ..... 1 unit  
Ref. 0023717 (120V)  
0024080 (230V)



**Allen Key Ø 1,5** ..... 1 unit  
Ref. 0741610



**Allen Key Ø 2,5** ..... 1 unit  
Ref. 0012574



**Spanner** ..... 1 unit  
Ref. 0017631



**Manual** ..... 1 unit  
Ref. 0028141

## Features and Connections

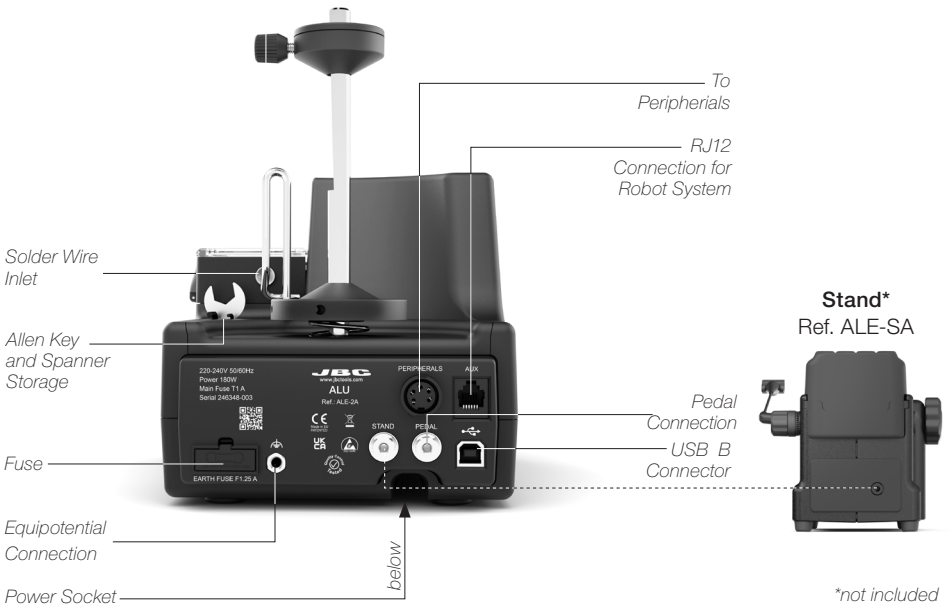
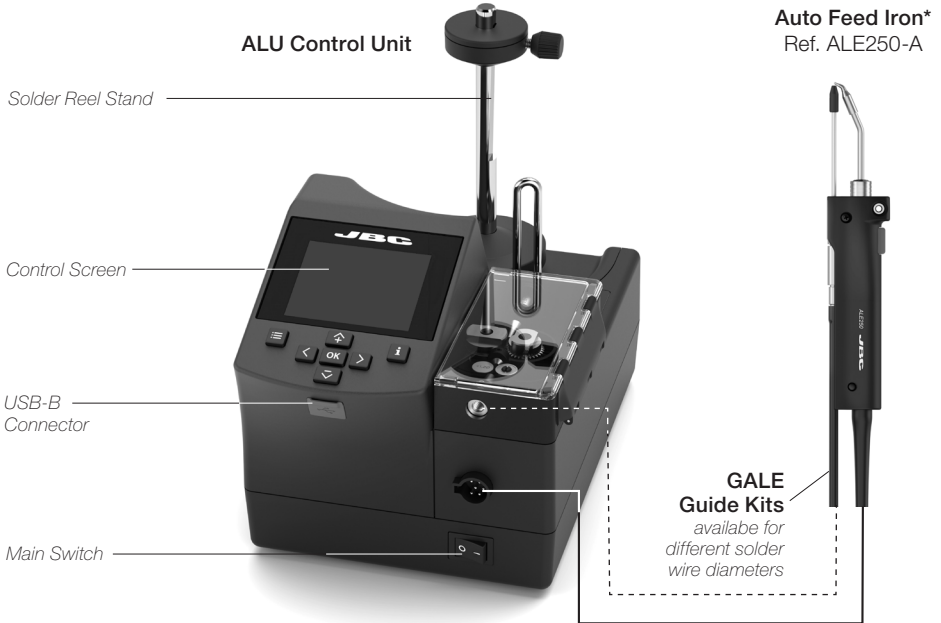

# Solder Reel Assembly

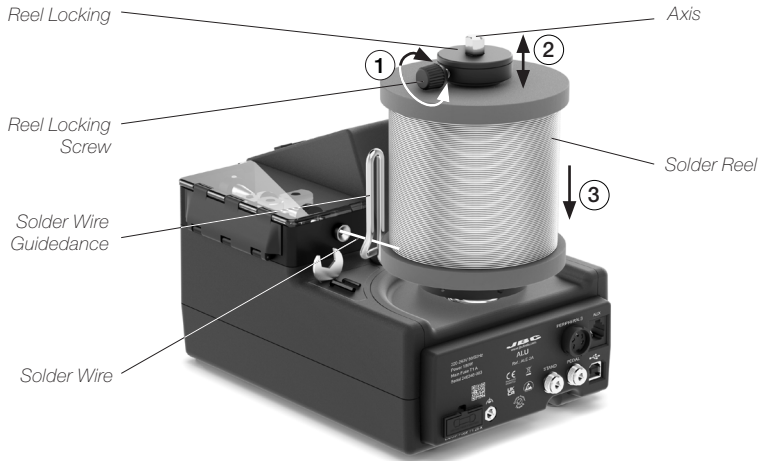

Open the reel locking screw (1) and remove the reel locking (2) from the axis.

Assemble the solder reel onto the axis (3) and reassemble the reel locking screw (1). The flat side of the axis must align with the inner flat side of the reel locking.

**Note:** Press lightly the reel locking (1) down before tightening the reel locking screw (2) to prevent free reel spinning.

**!** Insert the solder reel in such a way - when viewed from above - that the solder wire unwinds on the dispensing mechanism side (4).

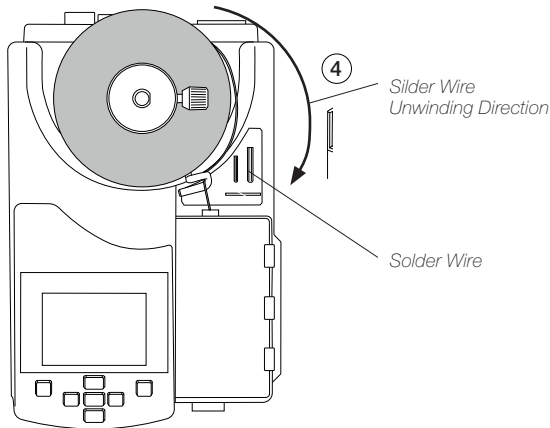

## Tool Assembly

Connect the tool to the control unit following this steps:

Insert and push the guide nozzle until the end (1) and tighten the screw (2). Then connect the tool connector (3).

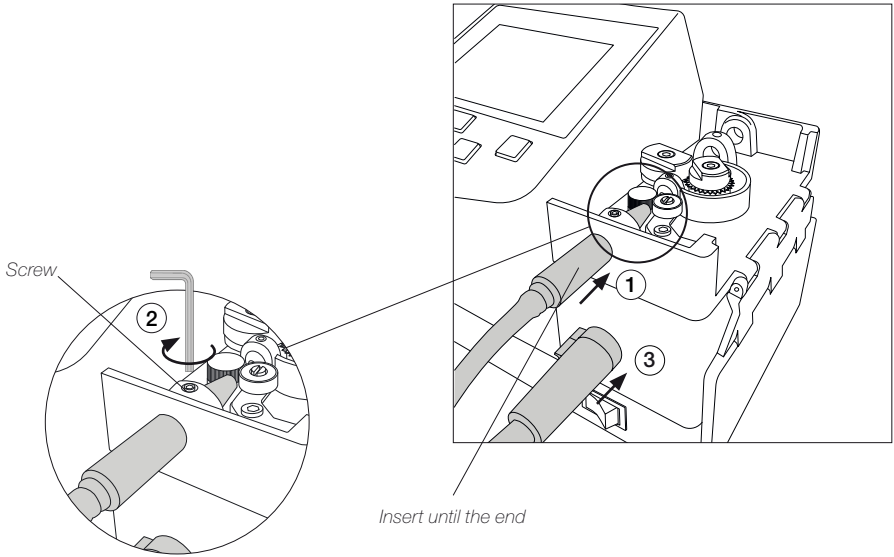

*Insert until the end*

## Solder Wire Loading

Pass the solder wire through the wire guidance and introduce the solder wire into the inlet nozzle (1) until it reaches the wheels (2).

Make sure the wire passes through the Intermediate Nozzle (5) and enters into the Guide Tube (6).

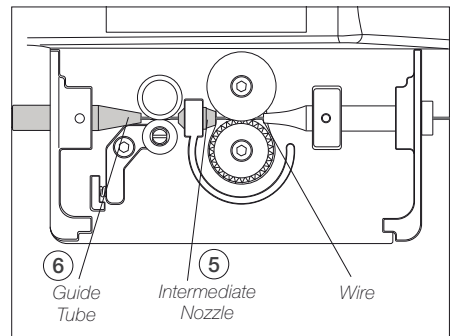
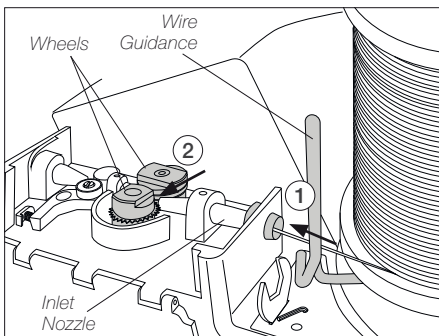

## Main Menu Screen

Access to Main Menu by  , select “Feeder Settings” (1) and then “Wire Diameter” (2) to adjust the value to the current solder wire diameter.

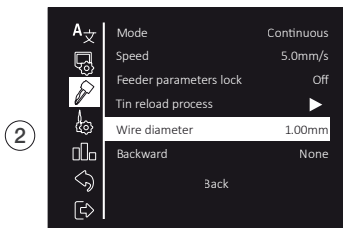
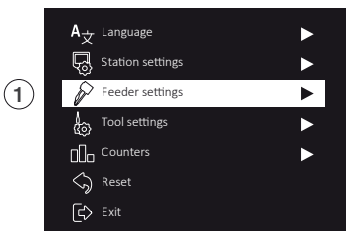

## Tin Reloaded Process Screen

Select “Tin Reloaded Process” (1) and then use  to feed the solder wire and advance until it comes out through the outlet nozzle. Keep  pressed and after a while the wire will advance faster.

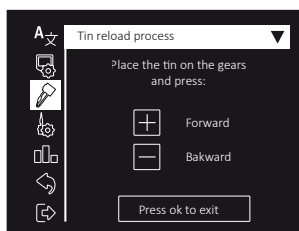
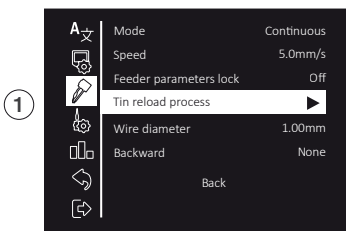

## Solder Wire Feeding

Forward the solder wire by pushing the dragging button (4) until the wire comes out of the tip (5).

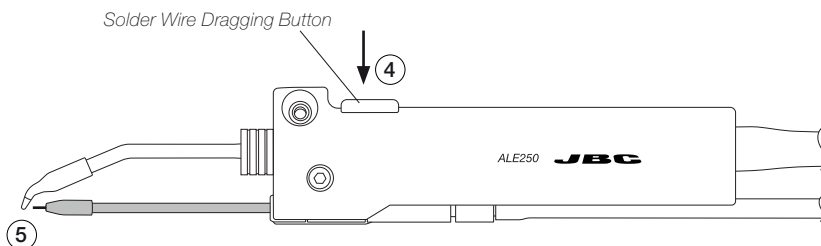

To feed the solder wire, alternatively the pedal P405 can be used. The pedal should be plugged in at the rear of the feeder control unit into the pedal connector.



## Control Process

### Feeder Setting Modes

Choose between “continuous”, “discontinuous” and “program” mode. Acces to Main Menu by , select “Feeder Settings” and then “Mode”.

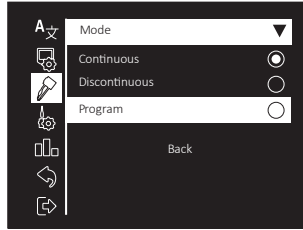

Depending on the selected mode, different parameters are available for setup.

#### Continuous Mode

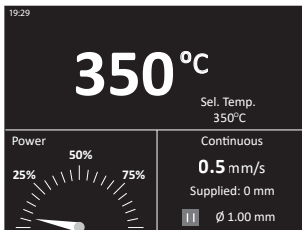

#### Discontinuous Mode

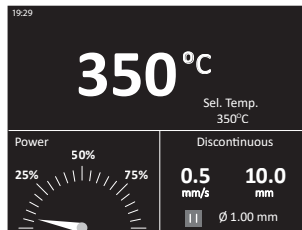

#### Program Mode

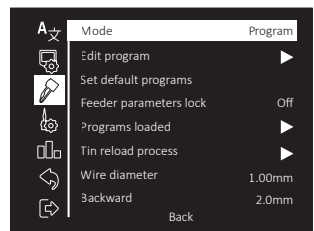
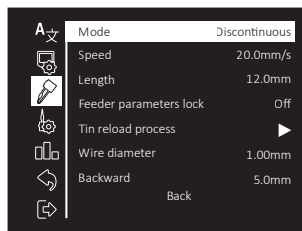
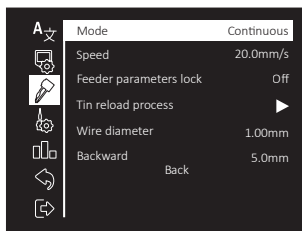
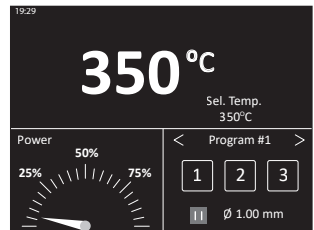

## Troubleshooting

Station troubleshooting available on the product page at [www.jbctools.com](http://www.jbctools.com)

# Control Process

## Program Mode

With AL you can define up to 5 feeder programs. Select “Edit Program” and access to the programm parameters.

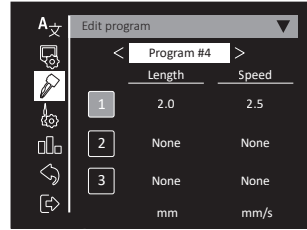
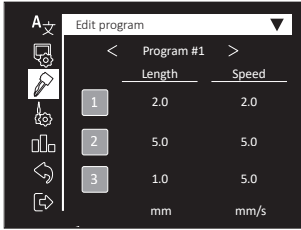

For each programm between 1 and 3 feeding steps (length and speed) should be defined. If less than 3 feedig steps are needed, set up wire length and speed to “0.0” and the parameter will change to “None”.

## Quick Access to Feeder Setting Modes

The solder wire dispensing values can directly set up from the work screen.

Press or to change the tool temperature value.

When the main screen is displayed, by pressing button speed and lenght value can be set up. Following parameters can be changed according to the different dispensing modes:

- Contiunous Mode: Speed
- Discontinuous Mode: Speed and length
- Program Mode: 3 feeding parameter pairs (length and speed) for every program.

**Note:** First select the program to be modified at the work screen by using and to switch between the programs.

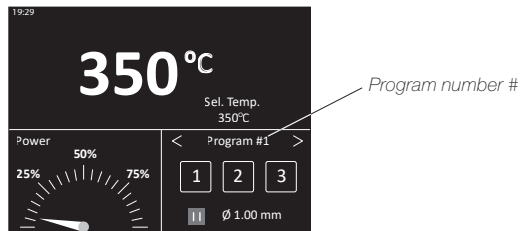



## Control Process

### Menu Screen

Default PIN: 0105

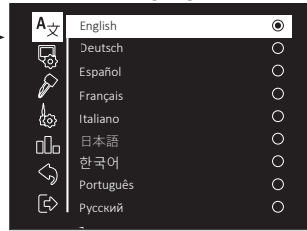
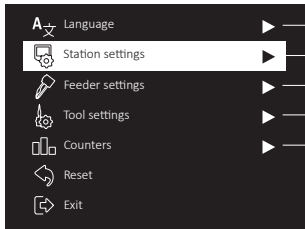

### Station Settings

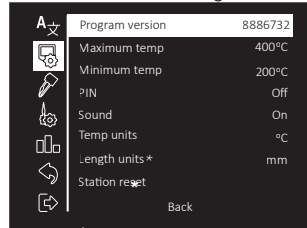

*\*choose between mm and inches*

### Feeder Settings

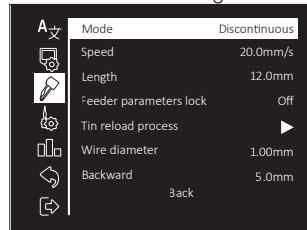

### Tool Settings

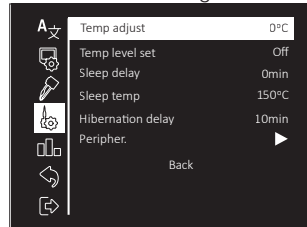

### Counters

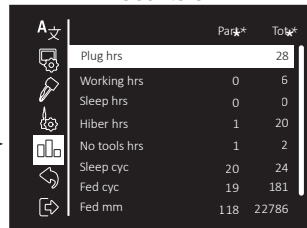

*\* partial and total counters are shown*

# Changing Guide Kits

## Changing Wheels and Blade

For this operation, disconnect the device from the mains. Disconnect the tool from the control unit and open its cover.

First disassemble the guide tube (6), the nozzles (2)+(3), then the Wheels, Blade and Clamp (4)+(5). Disassemble the Counter Wheel (1). Use the allen key and the spanner, provided with the station.

### Assembly with Solder Wire Perforation

Assemble the counter wheel (1).

Insert the intermediate nozzle (2) until its collar rests against the housing and tighten the screw.

Assemble the inlet nozzle (3).

Assemble the guide wheel (4) and tighten the screw.

Assemble the blade first, then mount the blade clamp (5) onto the same axis and tighten the screw. **Caution:** handle the blade carefully to avoid injury.

Insert the guide set (6).

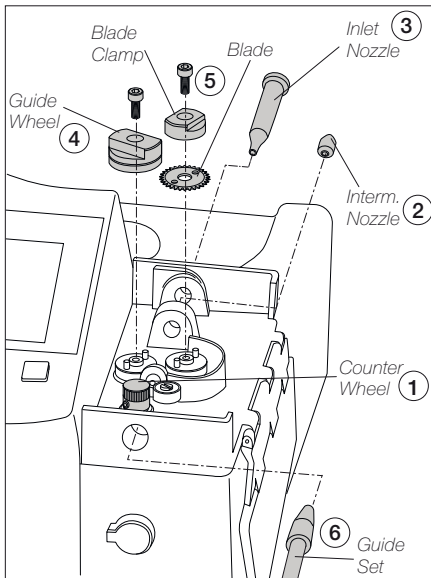

### Assembly without Solder Wire Perforation

Assemble the counter wheel (1).

Insert the intermediate nozzle (2) until its collar rests against the housing and tighten the screw.

Assemble the inlet nozzle (3).

Assemble the traction wheel (4) onto the axis and tighten the screw.

Assemble the support wheel (5) and tighten the screw.

Insert the guide set (6).

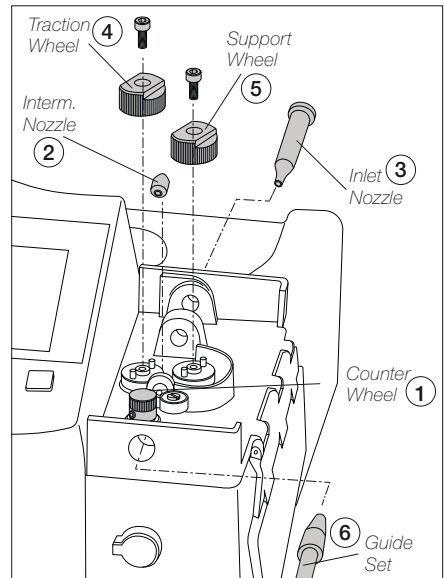

## Accessories

Various guide sets are available. Select the appropriate guide set depending on the solder wire diameter to be used.

### GALE Guide Sets for ALE250 with Solder Wire Perforation

#### GALEXV-A WITH SOLDER WIRE PERFORATION

Wire diameter	
XX	Diameter of use
08	∅0.8 mm ∅0.032 in
10	∅1.0 mm ∅0.040 in
12	∅1.2 mm ∅0.047 in
15	∅1.5 mm ∅0.059 in
16	∅1.6 mm ∅0.063 in

Guide tube
GALE08V-A 0028358
GALE10V-A 0028359
GALE12V-A 0028360
GALE15V-A 0028361
GALE16V-A 0028363

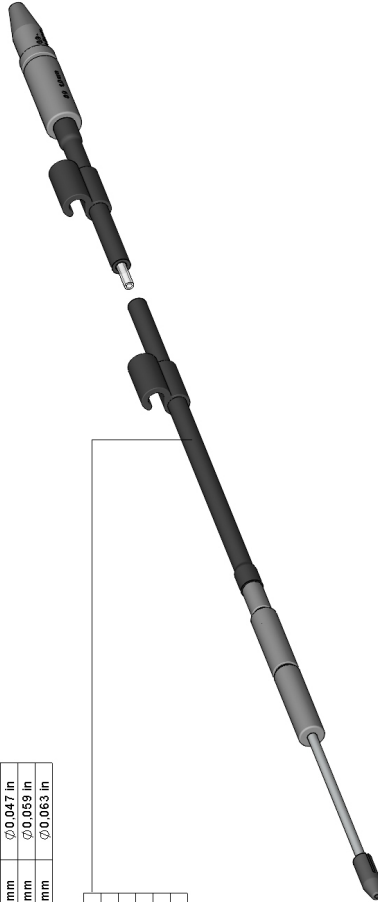

#### SPARE PARTS

Wire	Outlet nozzle	Nozzle	Guide wheel	Blade	Blade clamp	Inlet nozzle	Intern. nozzle	Counter wheel	Screws	Threaded stud	
GALE08V-A	0025270	0021158	0021696	0021555	0018638	0018632	0024955	0028693 (Supplied with SFI)	0026695 (X2)	0026696 (X3)	
GALE10V-A	0021560		0021699				0019170				0024956
GALE12V-A	0025272		0023738				0019171				0024957
GALE15V-A	0025274		0019696				0024233				0024958
GALE16V-A	0025276		0025922								0024959

# Accessories

## GALE Guide Sets for ALE250 without Solder Wire Perforation

### GALEXD-A WITHOUT SOLDER WIRE PERFORATION

XX	Wire diameter
	Range of use
04	∅0.38 - 0.40 mm ∅0.015 - 0.016 in
05	∅0.46 - 0.56 mm ∅0.018 - 0.022 in
06	∅0.60 - 0.64 mm ∅0.023 - 0.025 in
07	∅0.70 - 0.78 mm ∅0.028 - 0.031 in
08	∅0.80 - 0.82 mm ∅0.032 - 0.033 in
10	∅0.90 - 1.10 mm ∅0.036 - 0.044 in
12	∅1.14 - 1.27 mm ∅0.045 - 0.051 in
15	∅1.50 - 1.57 mm ∅0.060 - 0.063 in
16	∅1.60 - 1.63 mm ∅0.063 - 0.065 in
18	∅1.80 mm ∅0.073 in

Guide tube	
GALE04D-A	0028358
GALE05D-A	
GALE06D-A	
GALE07D-A	0028359
GALE08D-A	
GALE10D-A	0028360
GALE12D-A	0028361
GALE15D-A	0028362
GALE16D-A	
GALE18D-A	0028363

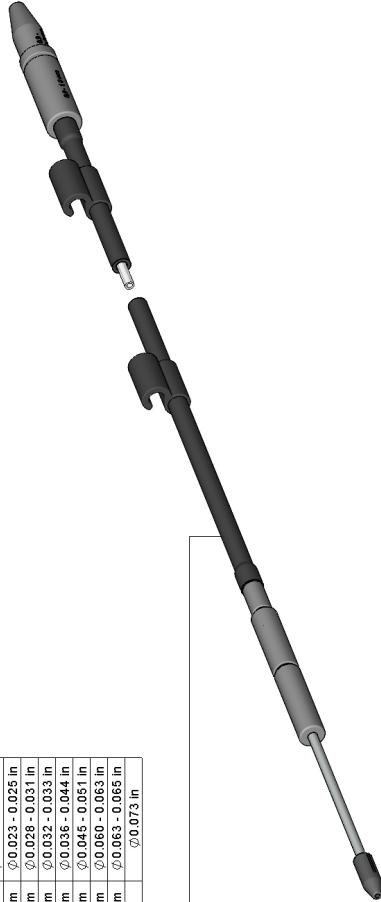

### SPARE PARTS

Wire ∅	Outlet nozzle	Nozzle	Traction wheel	Support wheel	Inlet nozzle	Interm. nozzle	Counter/wheel	Screws	Threaded stud
GALE04D-A	0025268		0019479	0020345	0019520	0024954	0026693	0026695 (x2)	0026696 (x3)
GALE05D-A				0019519			(Supplied with SF)		
GALE06D-A	0022994				0018632	0025291			
GALE07D-A	0025289			0019480	0019170	0024955			
GALE08D-A	0025270	0021158			0024957	0024957			
GALE10D-A	0021560			0019481	0019171	0024958			
GALE12D-A	0025272			0028367	0024233	0024959	0026694		
GALE15D-A	0025274				0024234				
GALE16D-A	0025276								
GALE18D-A	0021559								

## Maintenance

Before carrying out maintenance, always switch the device off and disconnect it from the mains. Allow the equipment to cool down.

- Clean the station screen with a glass cleaner or a damp cloth.
- Use a damp cloth to clean the casing and the tool. Alcohol can only be used to clean the metal parts.
- Periodically check that the metal parts of the tool and stand are clean so that the station can detect the tool status.

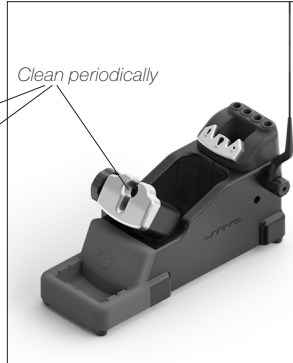

- Maintain tip surface clean and tinned prior to storage in order to avoid tip oxidation. Rusty and dirty surfaces reduce heat transfer to the solder joint.
- Periodically check all cables and tubes.
- Replace a blown fuse as follows:

**1.** Pull off the fuse holder and remove the fuse. If necessary use a tool to lever it off.

**2.** Insert the new fuse into the fuse holder and return it to the station.

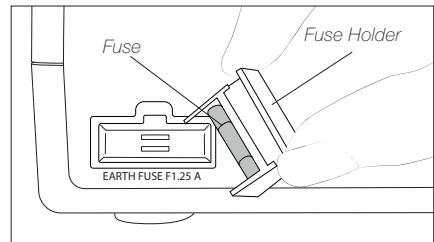
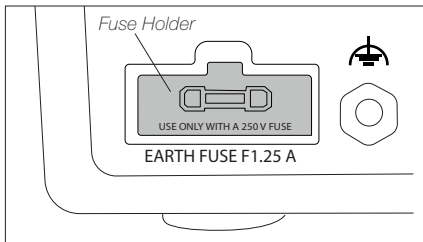

- Replace any defective or damaged pieces. Only use original JBC spare parts.
- Repairs should only be performed by a JBC authorized technical service.

## Safety



**It is imperative to follow safety guidelines to prevent electric shock, injury, fire or explosion.**

- Do not use the units for any purpose other than soldering or rework. Incorrect use may cause fire.
- The power cord must be plugged into approved bases. Be sure that it is properly grounded before use. When unplugging it, hold the plug, not the wire.
- Do not work on electrically live parts.
- The tool should be placed in the stand when not in use in order to activate the sleep mode. The soldering tip or nozzle, the metal part of the tool and the stand may still be hot even when the station is turned off. Handle with care, including when adjusting the stand position.
- Do not leave the appliance unattended when it is on.
- Do not cover the ventilation grills. Heat can cause inflammable products to ignite.
- Avoid flux coming into contact with skin or eyes to prevent irritation.
- Be careful with the fumes produced when soldering.
- Keep your workplace clean and tidy. Wear appropriate protection glasses and gloves when working to avoid personal harm.
- Utmost care must be taken with liquid tin waste which can cause burns.
- This appliance can be used by children over the age of eight and also persons with reduced physical, sensory or mental capabilities or lack of experience provided that they have been given adequate supervision or instruction concerning use of the appliance and understand the hazards involved. Children must not play with the appliance.
- Maintenance must not be carried out by children unless supervised.

## Specifications

### ALU

#### Auto-Feed Soldering Control Unit

**ALU-9A** 100V 50/60Hz. Input fuse: T2A. Earthing Fuse: F 1.25A. Output: 23.5V

**ALU-1A** 120V 50/60Hz. Input fuse: T2A. Earthing Fuse: F 1.25A. Output: 23.5V

**ALU-2A** 230V 50/60Hz. Input fuse: T1A. Earthing Fuse: F 1.25A. Output: 23.5V

- Output Peak Power: 130 W / 23.5 V
- Selectable Temperature Range: 90 - 450 °C / 190 - 840 °F
- Idle Temp. Stability (still air):  $\pm 1.5^{\circ}\text{C}$  /  $\pm 3^{\circ}\text{F}$  (Meets and exceed IPC J-STD-001)
- Temp. Accuracy:  $\pm 3\%$  (Using reference cartridge)
- Temp. Adjustment:  $\pm 50^{\circ}\text{C}$  /  $\pm 90^{\circ}\text{F}$  (Through station menu settings)
- Connections: USB-A Update and files import-export  
USB-B Software PC  
RJ12 Fume extractor connection
- Equipotential bonding: Optional connection to EPA
- Tip to Ground Voltage/Resistance:  $< 2$  mV RMS /  $< 2$  ohms  
Meets and exceed  
ANSI/ESD S20.20-2014 / IPC J-STD-001F
- Ambient Operating Temp: 10 - 50 °C / 50 - 122 °F
- Solder Wire Diameter: 0.4 - 1.6 mm / 0.02 - 0.06 in
- Max. Wire Length: 250 mm / 9.84 in (for discontinuous + program mode)
- Min. Wire Length: 0.5 mm / 0.02 in
- Forward Speed Range: 0.5 to 50 mm/s / 0.02 to 1.97 in/s
- Speed of Backward Funktion: 0.0 to 5.0 mm/s / 0.5 to 0.20 in/s
- Number of Programs: 5 Programs
- Number of Program Steps: 1 to 3 Steps (for each program)
- Control Unit Dimensions: 235 x 145 x 150 mm  
(L x W x H) 9.25 x 5.71 x 5.91 in
- Total Net Weight: 5.81 kg / 12.81 lb
- Package Dimensions / Weight: 368 x 368 x 195 mm / 6.72 Kg  
(L x W x H) 14.49 x 14.49 x 7.68 in / 14,82 lb

#### Compatible Solder Reel:

- Reel Weight: up to 2 kg / 4.41 lb
- Max. Reel Diameter: 100 mm / 3.94 in
- Max. Reel Height: 100 mm / 3.94 in

Complies with CE standards.  
ESD safe.

# JBC

---

## Warranty

JBC's 2 year warranty covers this equipment against all manufacturing defects, including the replacement of defective parts and labour.

Warranty does not cover product wear or misuse.

In order for the warranty to be valid, equipment must be returned, postage paid, to the dealer where it was purchased.

**Get 1 extra year JBC warranty by registering here:**  
<https://www.jbctools.com/productregistration/>  
**within 30 days of purchase.**

---



This product should not be thrown in the garbage.

In accordance with the European directive 2012/19/EU, electronic equipment at the end of its life must be collected and returned to an authorized recycling facility.



[www.jbctools.com](http://www.jbctools.com)



## X-ON Electronics

Largest Supplier of Electrical and Electronic Components

*Click to view similar products for [Soldering & Desoldering Stations](#) category:*

*Click to view products by [JBC Tools](#) manufacturer:*

Other Similar products are found below :

[GS1116](#) [WESD51D](#) [BH-010](#) [T0058768747](#) [CA0202](#) [CA0201](#) [WXD2N](#) [Q-7100-9000](#) [ALFA](#) [T0058757898](#) [WXD2010N](#) [T0058768762](#)  
[145-2000-ESDN](#) [T0058758721N](#) [0008473](#) [WTL1000-1](#) [700-3051-ESD](#) [0051514699N](#) [0051512199N](#) [T0058768725N](#) [ZD-415R](#) [ZD-415R-H](#)  
[WELPB102](#) [CVC-7CN0004P](#) [CVC-9CH0025S](#) [CVC-8CH0010S](#) [CV-H5-DSHP](#) [AP-SF](#) [AT-SA](#) [AT-SB](#) [DN-SF](#) [DR-SF](#) [DS-SF](#) [HD-SF](#)  
[0016344](#) [00B.SA.0](#) [0120CDK](#) [0551903](#) [0DIG20A45](#) [0IC1100A](#) [0ICV2000XV](#) [0T56](#) [CL-SFE/1 FILTERS](#) [PX0410/03P/5055](#) [RA150](#)  
[10G.SA.0](#) [36A.SA](#) [3C.SA](#) [3.TA](#) [AT850D/P](#)