

JBC

www.jbctools.com

INSTRUCTION MANUAL



GALE

Guide Kits for ALE250

This manual corresponds to the following references:

With Solder Wire Perforation:

- GALE08V-A** for wire Ø 0.8 mm / Ø 0.032 in
- GALE10V-A** for wire Ø 1.0 mm / Ø 0.040 in
- GALE12V-A** for wire Ø 1.2 mm / Ø 0.047 in
- GALE15V-A** for wire Ø 1.5 mm / Ø 0.059 in
- GALE16V-A** for wire Ø 1.6 mm / Ø 0.063 in

Without Solder Wire Perforation:

- GALE04D-A** for wire Ø 0.38 - 0.4 mm / Ø 0.015 - 0.016 in
- GALE05D-A** for wire Ø 0.46 - 0.56 mm / Ø 0.018 - 0.022 in
- GALE06D-A** for wire Ø 0.60 - 0.64 mm / Ø 0.023 - 0.025 in
- GALE07D-A** for wire Ø 0.70 - 0.78 mm / Ø 0.028 - 0.031 in
- GALE08D-A** for wire Ø 0.80 - 0.82 mm / Ø 0.032 - 0.033 in
- GALE10D-A** for wire Ø 0.90 - 1.10 mm / Ø 0.036 - 0.044 in
- GALE12D-A** for wire Ø 1.14 - 1.27 mm / Ø 0.045 - 0.051 in
- GALE15D-A** for wire Ø 1.50 - 1.57 mm / Ø 0.060 - 0.063 in
- GALE16D-A** for wire Ø 1.60 - 1.63 mm / Ø 0.063 - 0.065 in
- GALE18D-A** for wire Ø 1.8 mm / Ø 0.073 in

GALE Guide Kits for ALE250 with Solder Wire Perforation

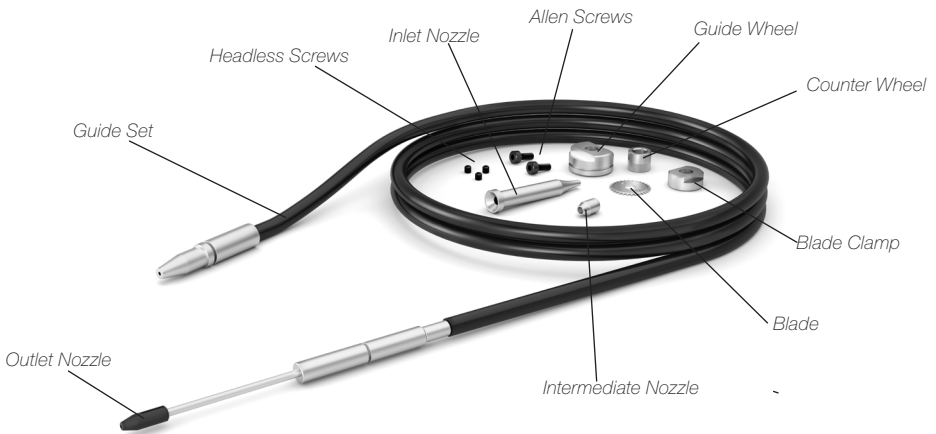

Packing List

The following items are included:

- Guide Set*** 1 unit
- Inlet Nozzle*** 1 unit
- Guide Wheel*** 1 unit
- Counter Wheel*** 1 unit
- Blade Clamp*** 1 unit
- Blade*** 1 unit
- Intermediate Nozzle*** 1 unit
- Outlet Nozzle*** 1 unit

- Allen Screws*** 2 units
- Headless Screws*** 3 units



- Manual** 1 unit

*see reference table on page 4

Ref. 0028365

GALE Guide Kits for ALE250 without Solder Wire Perforation

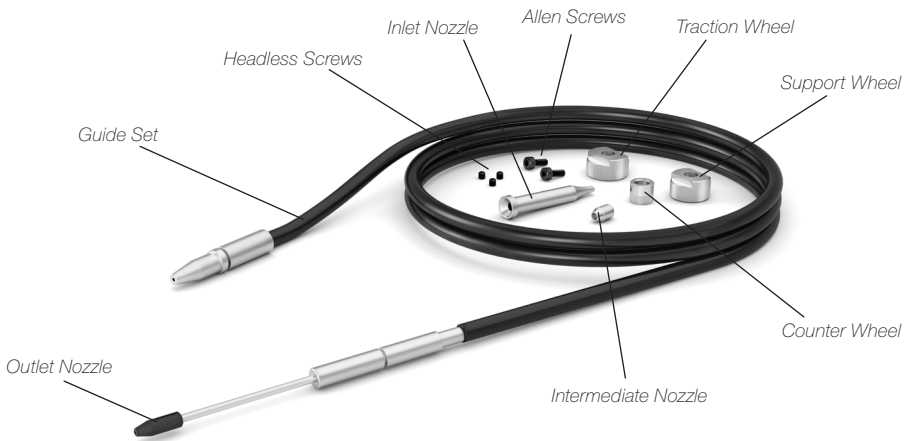

Packing List

The following items are included:

Guide Set*	1 unit
Inlet Nozzle*	1 unit
Traction Wheel*	1 unit
Support Wheel*	1 unit
Counter Wheel*	1 unit
Intermediate Nozzle*	1 unit
Outlet Nozzle*	1 unit

Allen Screws	2 units
Headless screws	3 units



Manual	1 unit
---------------------	--------

Ref. 0028365

*see reference table on page 5

GALE Guide Kits for ALE250 with Solder Wire Perforation

GALEXXV-A WITH SOLDER WIRE PERFORATION

Wire diameter	
XX	Diameter of use
08	∅0.8 mm ∅0.032 in
10	∅1.0 mm ∅0.040 in
12	∅1.2 mm ∅0.047 in
15	∅1.5 mm ∅0.059 in
16	∅1.6 mm ∅0.063 in

Guide tube
GALE08V-A 0028358
GALE10V-A 0028359
GALE12V-A 0028360
GALE15V-A 0028361
GALE16V-A 0028363

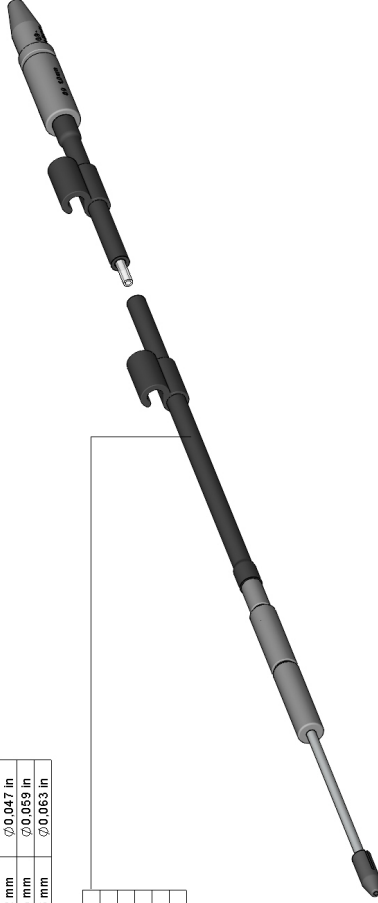

SPARE PARTS

Wire	Outlet nozzle	Nozzle	Guide wheel	Blade	Blade clamp	Inlet nozzle	Intern. nozzle	Counter wheel	Screws	Threaded stud
GALE08V-A	0025270	0021158	0021696	0021555	0018638	0018632	0024955	0026693 (Supplied with SF)	0026695 (X2)	0026696 (X3)
GALE10V-A	0021560		0021699			0019170	0024956			
GALE12V-A	0025272		0023738			0019171	0024957			
GALE15V-A	0025274		0019696			0024233	0024958			
GALE16V-A	0025276		0025922				0024959			

GALE Guide Kits for ALE250 without Solder Wire Perforation

GALEXD-A WITHOUT SOLDER WIRE PERFORATION

XX	Wire diameter
	Range of use
04	∅0.38 - 0.40 mm ∅0.015 - 0.016 in
05	∅0.46 - 0.56 mm ∅0.018 - 0.022 in
06	∅0.60 - 0.64 mm ∅0.023 - 0.025 in
07	∅0.70 - 0.78 mm ∅0.028 - 0.031 in
08	∅0.80 - 0.82 mm ∅0.032 - 0.033 in
10	∅0.90 - 1.10 mm ∅0.036 - 0.044 in
12	∅1.14 - 1.27 mm ∅0.045 - 0.051 in
15	∅1.50 - 1.57 mm ∅0.060 - 0.063 in
16	∅1.60 - 1.63 mm ∅0.063 - 0.065 in
18	∅1.80 mm ∅0.073 in

Guide tube
GALE04D-A 0028358
GALE05D-A 0028359
GALE06D-A 0028360
GALE07D-A 0028361
GALE08D-A 0028362
GALE10D-A 0028363
GALE12D-A 0028361
GALE15D-A 0028362
GALE16D-A 0028363
GALE18D-A 0028363

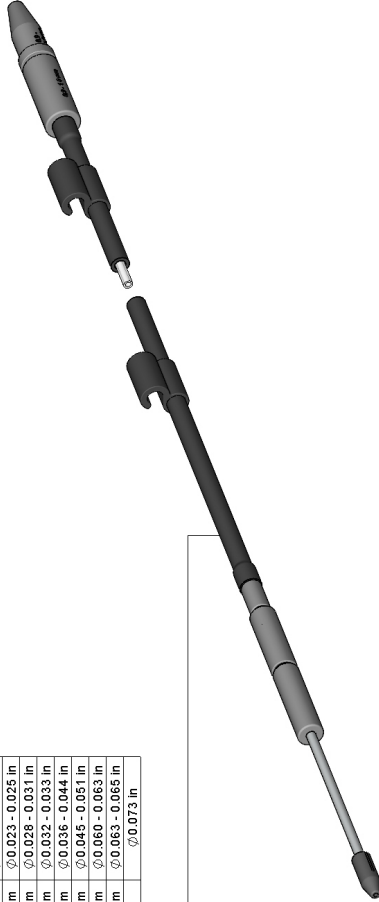

SPARE PARTS

Wire ∅	Outlet nozzle	Nozzle	Traction wheel	Support wheel	Inlet nozzle	Interm. nozzle	Counter/wheel	Screws	Threaded stud
GALE04D-A	0025268			0020345		0024954			
GALE05D-A				0019519	0019520		0026693		
GALE06D-A	0022994						(Supplied with SF)	0026695 (x2)	0026696 (x3)
GALE07D-A	0025289								
GALE08D-A	0025270			0019480					
GALE10D-A	0021560	0021158	0019479						
GALE12D-A	0025272			0019481					
GALE15D-A	0025274								
GALE16D-A	0025276			0028367	0024233	0024958			
GALE18D-A	0021659				0024234	0024950			

Changing Guide Kits

Changing Wheels and Blade

For this operation, disconnect the device from the mains. Disconnect the tool from the control unit and open its cover.

First disassemble the guide tube (6), the nozzles (2)+(3), then the wheels, blade and clamp (4)+(5). Disassemble the counter wheel (1). Use the allen key and the spanner, provided with the station.

Assembly with Solder Wire Perforation:

Assemble the counter wheel (1).

Insert the intermediate nozzle (2) until its collar rests against the housing and tighten the screw.

Assemble the inlet nozzle (3).

Assemble the guide wheel* (4) and tighten the screw.

Assemble the blade first, then mount the blade clamp (5) onto the same axis and tighten the screw. **Caution:** handle the blade carefully to avoid injury.

Insert the guide set (6).

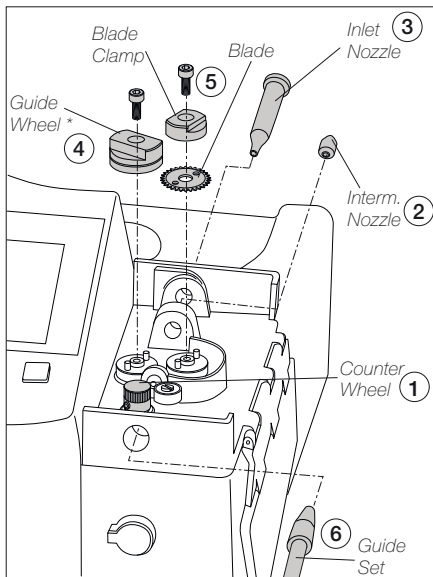

Assembly without Solder Wire Perforation:

Assemble the counter wheel (1).

Insert the intermediate nozzle (2) until its collar rests against the housing and tighten the screw.

Assemble the inlet nozzle (3).

Assemble the support wheel* (4) onto the axis and tighten the screw.

Assemble the traction wheel (5) and tighten the screw.

Insert the guide set (6).

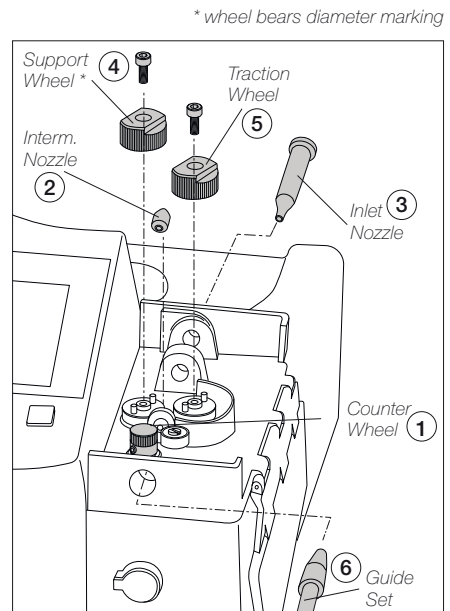

Replacing Guide Sets

Once the tool is disconnected from the control unit and has cooled down, follow these instructions:

Disassemble the outlet nozzle (1) from the guide set.

Loosen the guide set screw (2), take out the guide set (3) and insert the desired one.

Put the outlet nozzle (1) back on again. Leave a gap of 8 to 10 mm (0.31 to 0.39 in) between the cartridge tip and the outlet nozzle (4).

Once the guide nozzle length is adjusted tighten the guide set screw (2).

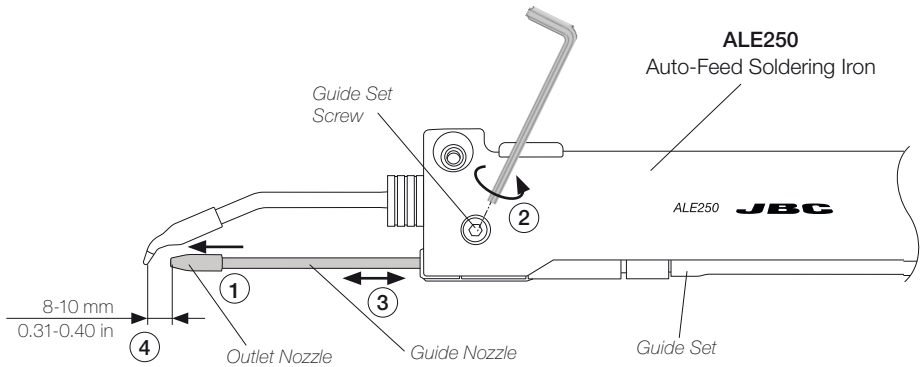

Tool Assembly

Connect the tool to the control unit following this steps:

Insert and push the guide nozzle until the end (1) and tighten the screw (2). Then connect the tool connector (3).

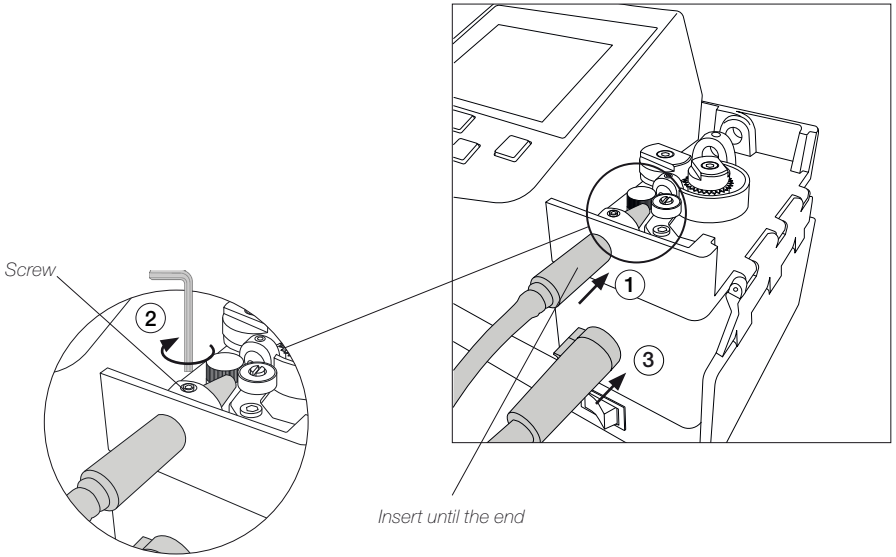

Solder Wire Loading

Pass the solder wire through the wire guidance and introduce the solder wire into the inlet nozzle (1) until it reaches the wheels (2).

Make sure the wire passes through the Intermediate Nozzle (5) and enters into the Guide Tube (6).

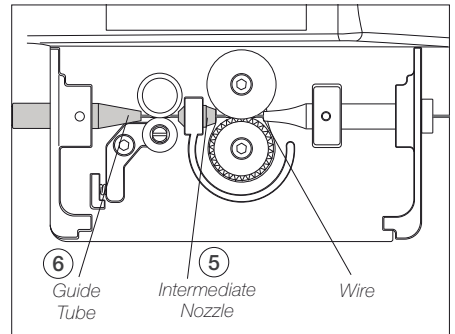
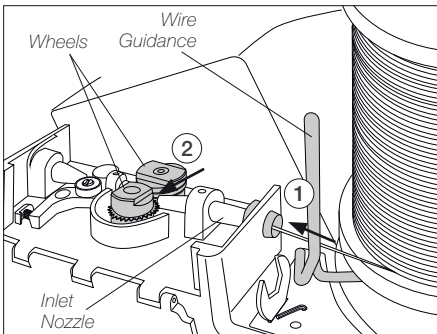

Main Menu Screen

Access to Main Menu by  , select “Feeder Settings” (1) and then “Wire Diameter” (2) to adjust the value to the current solder wire diameter.

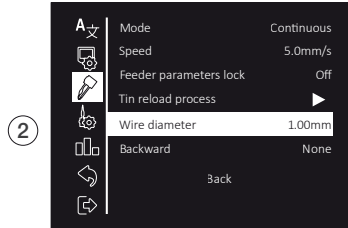
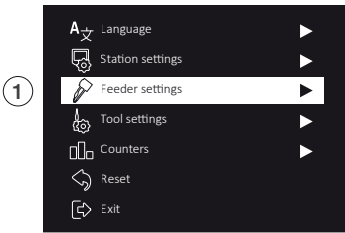

Tin Reloaded Process Screen

Select “Tin Reloaded Process” (1) and then use  to feed the solder wire and advance until it comes out through the outlet nozzle. Keep  pressed and after a while the wire will advance faster.

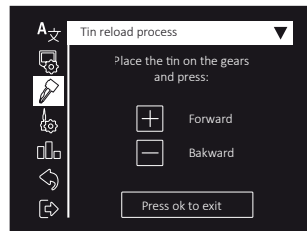
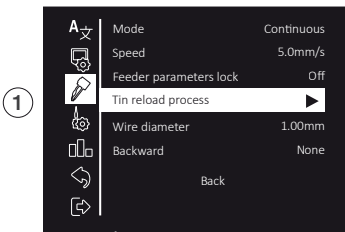

Solder Wire Feeding

Forward the solder wire by pushing the dragging button (4) until the wire comes out of the tip (5).

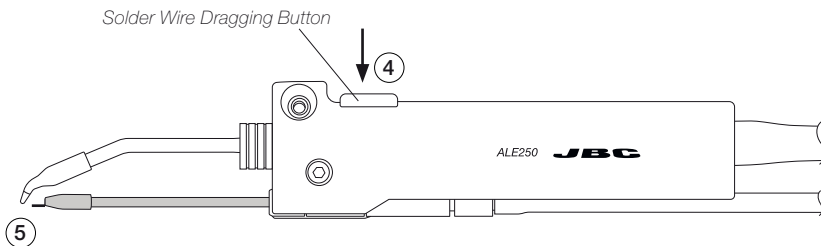

To feed the solder wire, alternatively the pedal P405 can be used. The pedal should be plugged in at the rear of the feeder control unit into the pedal connector.



Specifications

GALE

Guide Kits for ALE250

With Perforation:

Ref.: **GALE08V-A** wire \varnothing 0.8 mm / \varnothing 0.032 in
 Ref.: **GALE10V-A** wire \varnothing 1.0 mm / \varnothing 0.040 in
 Ref.: **GALE12V-A** wire \varnothing 1.2 mm / \varnothing 0.047 in
 Ref.: **GALE15V-A** wire \varnothing 1.5 mm / \varnothing 0.059 in
 Ref.: **GALE16V-A** wire \varnothing 1.6 mm / \varnothing 0.063 in

Total Net Weight:

108 g / 0.24 lb
 108 g / 0.24 lb
 94 g / 0.21 lb
 94 g / 0.21 lb
 94 g / 0.21 lb

Package Weight:

200 g / 0.44 lb
 200 g / 0.44 lb
 186 g / 0.41 lb
 186 g / 0.41 lb
 186 g / 0.41 lb

Without Perforation:

GALE04D-A for wire \varnothing 0.38 - 0.4 mm / \varnothing 0.015 - 0.016 in
GALE05D-A for wire \varnothing 0.46 - 0.56 mm / \varnothing 0.018 - 0.022 in
GALE06D-A for wire \varnothing 0.60 - 0.64 mm / \varnothing 0.023 - 0.025 in
GALE07D-A for wire \varnothing 0.70 - 0.78 mm / \varnothing 0.028 - 0.031 in
GALE08D-A for wire \varnothing 0.80 - 0.82 mm / \varnothing 0.032 - 0.033 in
GALE10D-A for wire \varnothing 0.90 - 1.10 mm / \varnothing 0.036 - 0.044 in
GALE12D-A for wire \varnothing 1.14 - 1.27 mm / \varnothing 0.045 - 0.051 in
GALE15D-A for wire \varnothing 1.50 - 1.57 mm / \varnothing 0.060 - 0.063 in
GALE16D-A for wire \varnothing 1.60 - 1.63 mm / \varnothing 0.063 - 0.065 in
GALE18D-A for wire \varnothing 1.8 mm / \varnothing 0.073 in

104 g / 0.23 lb
 104 g / 0.23 lb
 104 g / 0.23 lb
 104 g / 0.23 lb
 104 g / 0.23 lb
 90 g / 0.20 lb
 90 g / 0.20 lb
 90 g / 0.20 lb
 90 g / 0.20 lb
 90 g / 0.20 lb

196 g / 0.43 lb
 196 g / 0.43 lb
 196 g / 0.43 lb
 196 g / 0.43 lb
 196 g / 0.43 lb
 182 g / 0.40 lb
 182 g / 0.40 lb
 182 g / 0.40 lb
 182 g / 0.40 lb
 182 g / 0.40 lb

- Guide Tube Length: 126 cm / 49.6 in
 - Package Dimensions: 245 x 185 x 45 mm
 (L x W x H) 9.65 x 7.28 x 1.77 in

Complies with CE standards.
 ESD safe



Warranty

JBC's 2 year warranty covers this equipment against all manufacturing defects, including the replacement of defective parts and labour.

Warranty does not cover product wear or misuse.

In order for the warranty to be valid, equipment must be returned, postage paid, to the dealer where it was purchased.

Get 1 extra year JBC warranty by registering here:

**<https://www.jbctools.com/productregistration/>
within 30 days of purchase.**



This product should not be thrown in the garbage.

In accordance with the European directive 2012/19/EU, electronic equipment at the end of its life must be collected and returned to an authorized recycling facility.



X-ON Electronics

Largest Supplier of Electrical and Electronic Components

Click to view similar products for [Soldering & Desoldering Stations](#) category:

Click to view products by [JBC Tools](#) manufacturer:

Other Similar products are found below :

[T0058768747](#) [CA0201](#) [WXD2N](#) [145-2000-ESDN](#) [T0058758721N](#) [0051514699N](#) [0051512199N](#) [TS2300D](#) [WELPB102](#) [0552406](#) [5SS-554-](#)
[H](#) [5SS-553-H](#) [209202](#) [MFR-2240](#) [DDSE-2QD](#) [SRWS-2SC](#) [DMPSE-2QB](#) [T245-GA](#) [0ICV2005A](#) [MX-570](#) [108ESD](#) [DS2500D](#) [LS30](#)
[T0052923699](#) [0IC2205VC](#) [MS-GT-Y050](#) [CDN-2QF](#) [ZD-154-1C](#) [JNA-2B](#) [0IC1105A](#) [T0053451699](#) [TESE-2B](#) [CVC-9CH0050S](#) [ST802](#)
[0016268](#) [ZD-154-1A](#) [ZD-11L](#) [QUICK 959D+](#) [CHB-B](#) [0IC1135A](#) [0IC1305](#) [DMSE-2QB](#) [JTSE-2QB](#) [0ICV2005AC](#) [HCT-910-21](#)
[T0058748850N](#) [NH-A](#) [MFR-1140](#) [GALE07D-A](#) [T0053452699](#)