

FEATURES

- $R_{DS(ON)} < 4.4\Omega$ @ $V_{GS}=10V, I_D=1A$
- Fast switching capability
- Lead free in compliance with EU RoHS directive.
- Improved dv/dt capability, high ruggedness

MECHANICAL DATA

- Case: TO-220, ITO-220, TO-251, TO-252, TO-262, TO-263 Package

Ordering Information

Part No.	Package	Packing
2N65-TU	TO-220	50pcs / Tube
2N65F-TU	ITO-220	50pcs / Tube
2N65E-TU	TO-262	50pcs / Tube
2N65D-TU	TO-263	50pcs / Tube
2N65D-TR	TO-263	800pcs / 13"Reel
2N65N-TU	TO-251	75pcs / Tube
2N65M-TU	TO-252	75pcs / Tube
2N65M-TR	TO-252	2.5Kpcs / 13"Reel

PRODUCT SUMMARY

V_{DS} (V)	$R_{DS(on)}$ (Ω)	I_D (A)
650	4.4 @ $V_{GS}=10V$	2

TO-220AB

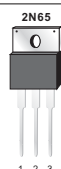

ITO-220AB

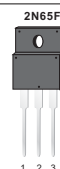

TO-263



TO-262



TO-251



TO-252



Block Diagram

Pin Definition:

1. Gate
2. Drain
3. Source

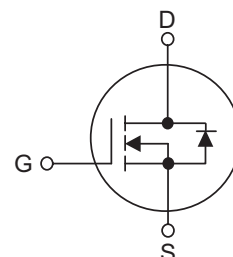

ABSOLUTE MAXIMUM RATINGS (T_C=25 C, unless otherwise specified)

PARAMETER	SYMBOL	RATINGS	UNIT
Drain-Source Voltage	V_{DSS}	650	V
Gate-Source Voltage	V_{GSS}	3 0	V
Continuous Drain Current	I_D	2.0	A
Pulsed Drain Current (Note 2)	I_{DM}	8.0	A
Avalanche Energy	E_{AS}	115	mJ
Power Dissipation	TO-220/TO-263/TO-262	44	W
	ITO-220	23	
	TO-251/TO-252	34	
Junction Temperature	T_J	+150	C
Storage Temperature	T_{STG}	-55 ~ +150	C

Notes: 1. Absolute maximum ratings are those values beyond which the device could be permanently damaged.

Absolute maximum ratings are stress ratings only and functional device operation is not implied.

2. Repetitive Rating : Pulse width limited by maximum junction temperature

3. L=30mH, I_{AS}=2.7A, V_{DD}=50V, R_G=25 Ω , Starting T_J=25 C

2N65

650V N-Channel Power MOSFET

THERMAL DATA

PARAMETER		SYMBOL	RATING	UNIT
Junction to Ambient	TO-220/ITO-220 TO-262/TO-263	θ_{JA}	62.5	C/W
	TO-251/TO-252		110	
	TO-220/TO-263/TO-262		2.35	
Junction to Case	ITO-220	θ_{JC}	5.5	C/W
	TO-251/TO-252		2.9	

ELECTRICAL CHARACTERISTICS (T_C=25 C, unless otherwise specified)

PARAMETER		SYMBOL	TEST CONDITIONS	MIN	TYP	MAX	UNIT	
OFF CHARACTERISTICS								
Drain-Source Breakdown Voltage		BV _{DSS}	V _{GS} =0V, I _D =250μA	650			V	
Drain-Source Leakage Current		I _{DSS}	V _{DS} =650V, V _{GS} =0V			10	μA	
Gate- Source Leakage Current	Forward	I _{GSS}	V _G =30V, V _{DS} =0V			100	nA	
	Reverse		V _G =-30V, V _{DS} =0V			-100	nA	
ON CHARACTERISTICS								
Gate Threshold Voltage		V _{GS(TH)}	V _{DS} =V _{GS} , I _D =250μA	2.0		4.0	V	
Static Drain-Source On-State Resistance		R _{DS(ON)}	V _{GS} =10V, I _D =1.0A		4	4.4	Ω	
DYNAMIC CHARACTERISTICS								
Input Capacitance		C _{ISS}	V _{DS} =25V, V _{GS} =0V, f=1MHz		300		pF	
Output Capacitance		C _{OSS}				45		pF
Reverse Transfer Capacitance		C _{RSS}				2		pF
SWITCHING CHARACTERISTICS								
Turn-On Delay Time		t _{D(ON)}	V _{DD} =300V, I _D =2A, R _G =25Ω (Note 1, 2)		10		ns	
Turn-On Rise Time		t _R			25		ns	
Turn-Off Delay Time		t _{D(OFF)}			20		ns	
Turn-Off Fall Time		t _F			25		ns	
Total Gate Charge		Q _G			5.7		nC	
Gate-Source Charge		Q _{GS}	V _{DS} =480V, I _D =2.4A, V _{GS} =10V (Note 1, 2)		1.8		nC	
Gate-Drain Charge		Q _{GD}			2		nC	
DRAIN-SOURCE DIODE CHARACTERISTICS AND MAXIMUM RATINGS								
Drain-Source Diode Forward Voltage		V _{SD}	V _{GS} =0V, I _S =2.0A			1.4	V	
Maximum Continuous Drain-Source Diode Forward Current		I _S				2.0	A	
Maximum Pulsed Drain-Source Diode Forward Current		I _{SM}				8.0	A	
Reverse Recovery Time		t _{rr}	V _{GS} =0V, I _S =2A		357		ns	
Reverse Recovery Charge		Q _{RR}	di/dt=100A/μs (Note 1)		2		μC	

- Notes: 1. Pulse Test: Pulse width ≤300μs, Duty cycle ≤2%.
2. Essentially independent of operating temperature.

2N65

650V N-Channel Power MOSFET

TEST CIRCUITS AND WAVEFORMS

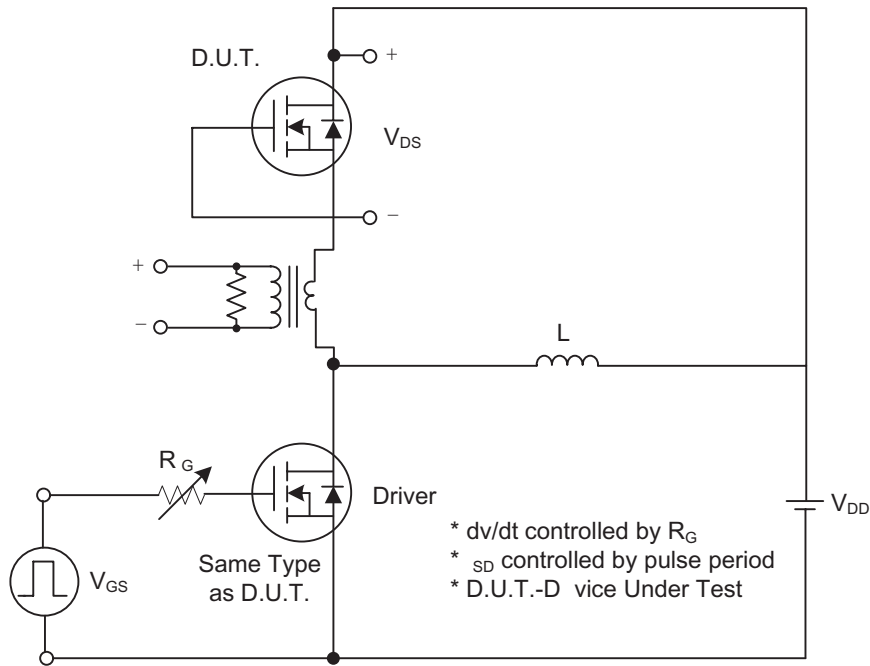

Peak Diode Recovery dv/dt Test Circuit

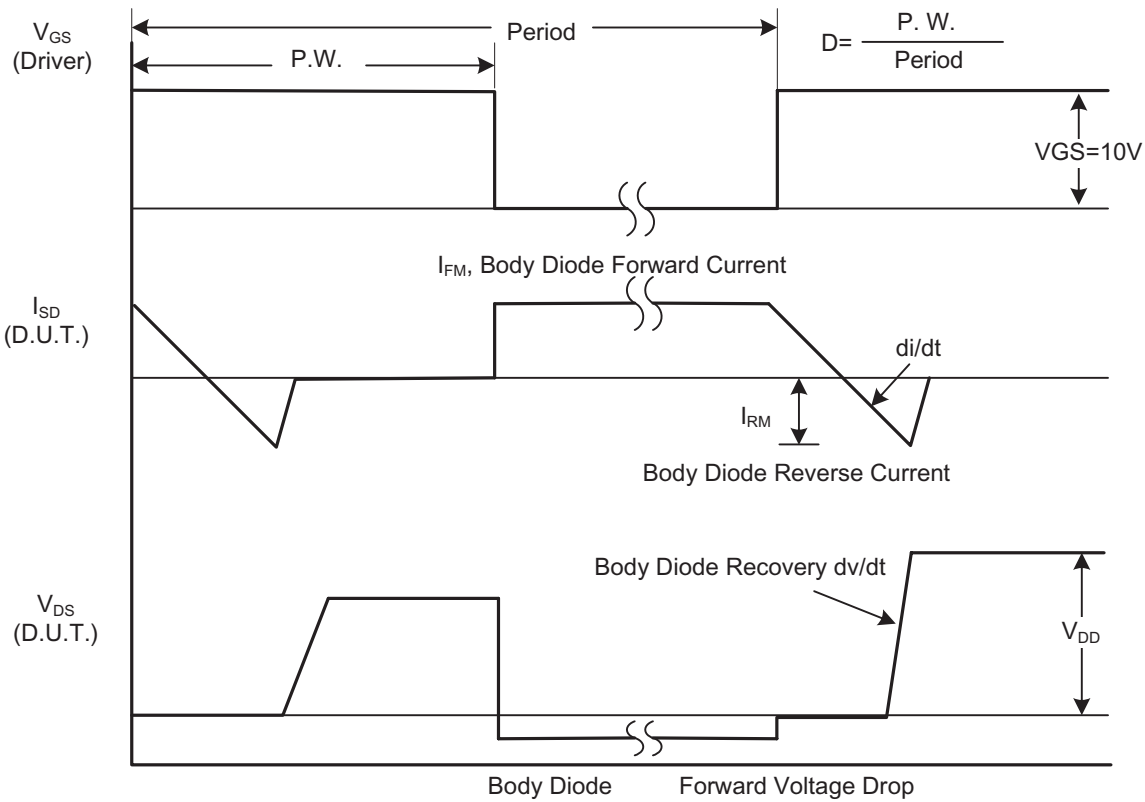

Peak Diode Recovery dv/dt Waveforms

2N65

650V N-Channel Power MOSFET

TEST CIRCUITS AND WAVEFORMS(Cont.)

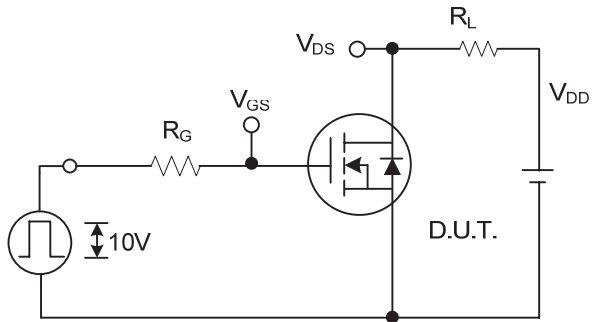

Switching Test Circuit

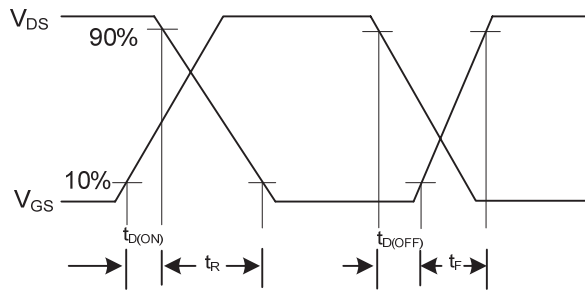

Switching Waveforms

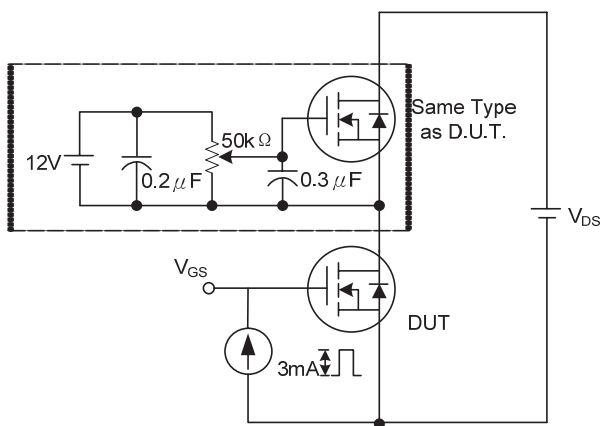

Gate Charge Test Circuit

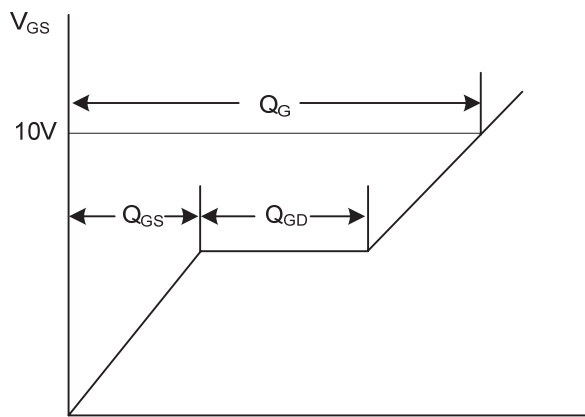

Charge
Gate Charge Waveform

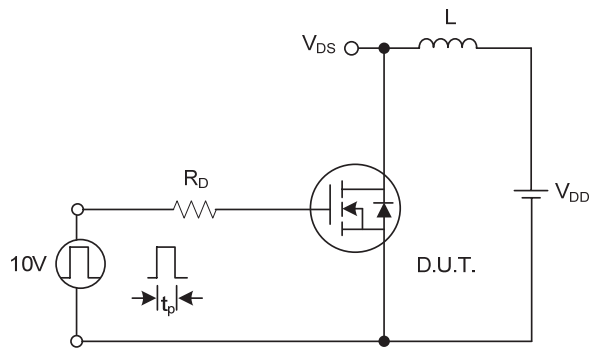

Unclamped Inductive Switching Test Circuit

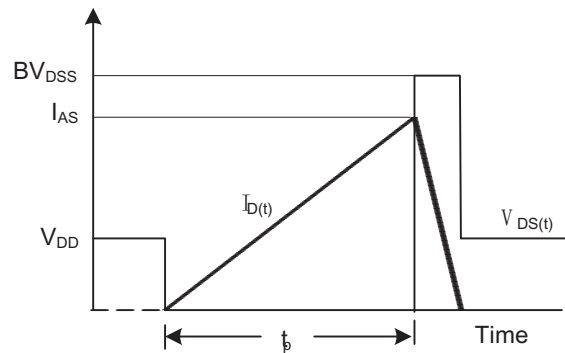

Unclamped Inductive Switching Waveforms

2N65

650V N-Channel Power MOSFET

TYPICAL CHARACTERISTICS

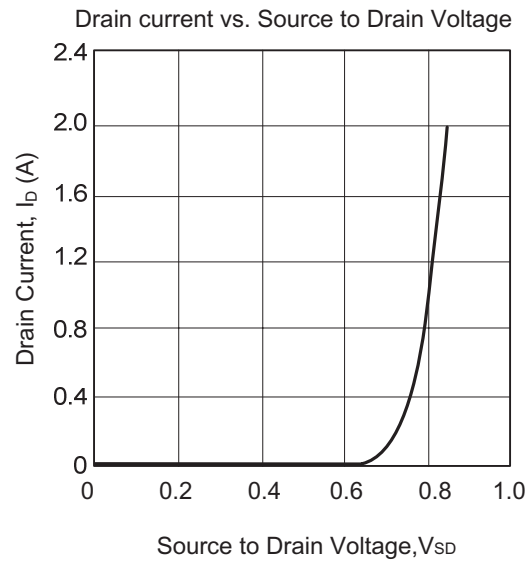
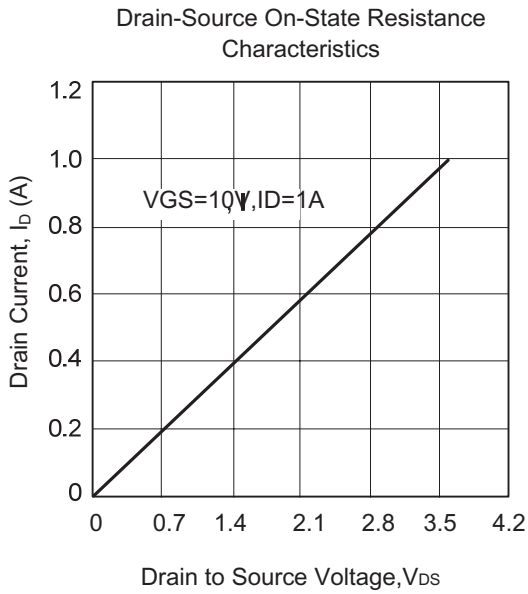
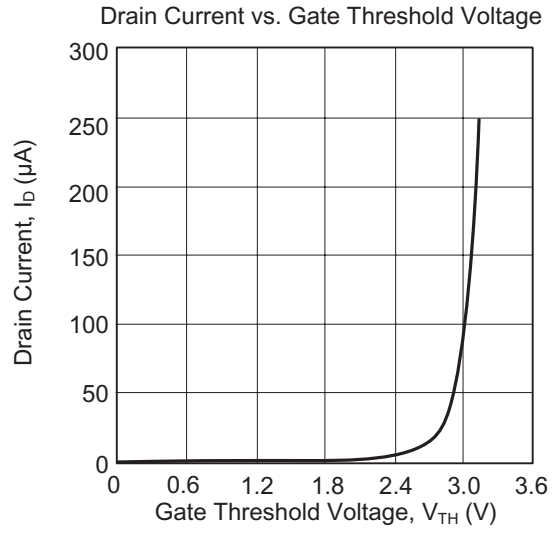
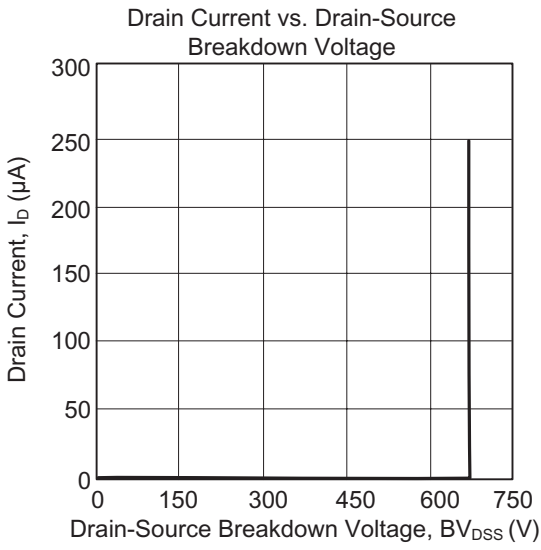

2N65

650V N-Channel Power MOSFET

TO-220AB

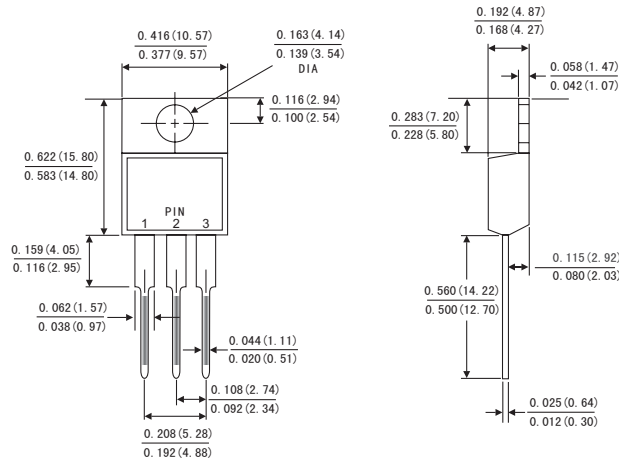

ITO-220AB

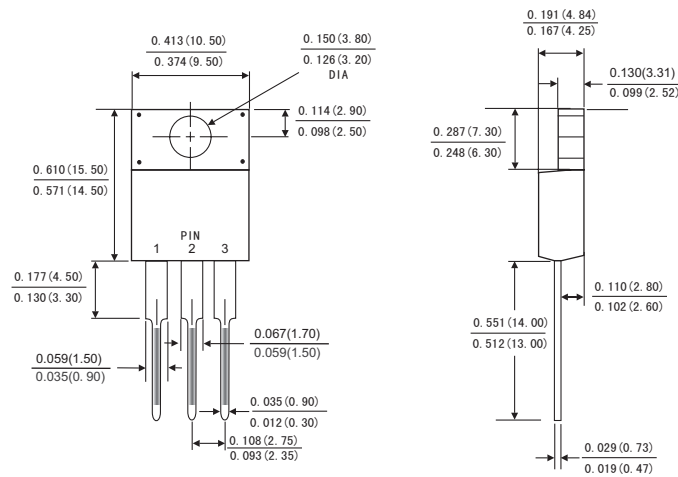

TO-263

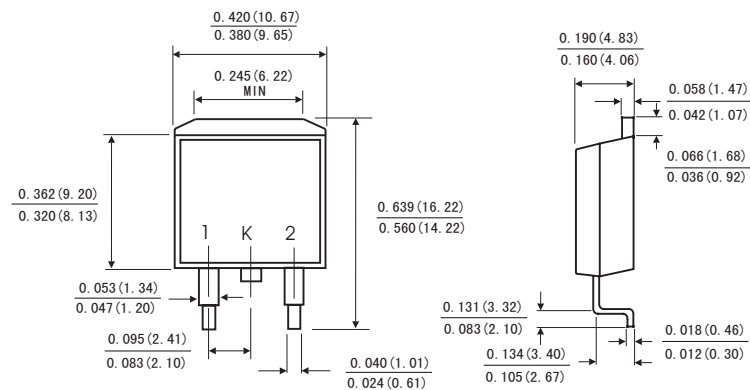

Dimensions in inches and (millimeters)

2N65

650V N-Channel Power MOSFET

TO-252 (DPAK)

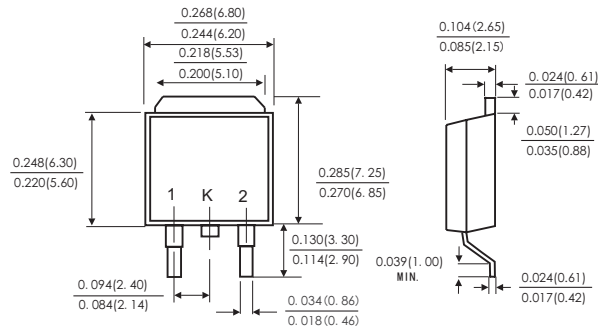

Dimensions in inches and (millimeters)

TO-251

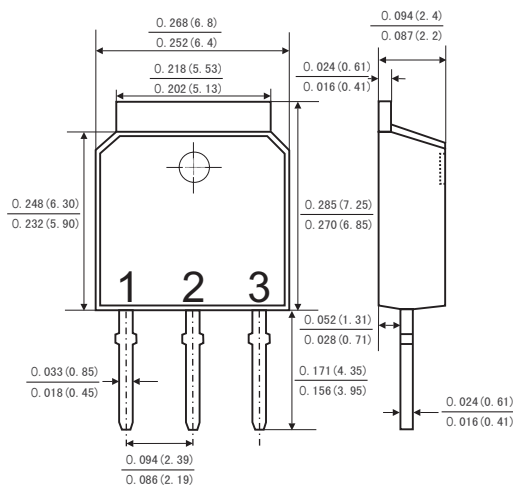

Dimensions in inches and (millimeters)

TO-262

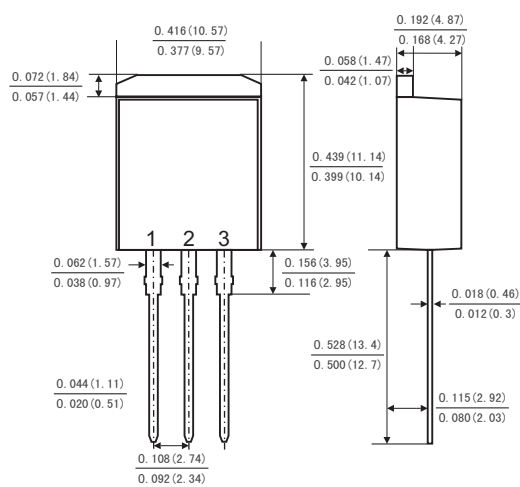

Dimensions in inches and (millimeters)

X-ON Electronics

Largest Supplier of Electrical and Electronic Components

Click to view similar products for [MOSFET](#) category:

Click to view products by [JH](#) manufacturer:

Other Similar products are found below :

[614233C](#) [648584F](#) [MCH3443-TL-E](#) [MCH6422-TL-E](#) [FDPF9N50NZ](#) [FW216A-TL-2W](#) [FW231A-TL-E](#) [APT5010JVR](#) [NTNS3A92PZT5G](#)
[IRF100S201](#) [JANTX2N5237](#) [2SK2464-TL-E](#) [2SK3818-DL-E](#) [FCA20N60_F109](#) [FDZ595PZ](#) [STD6600NT4G](#) [FSS804-TL-E](#) [2SJ277-DL-E](#)
[2SK1691-DL-E](#) [2SK2545\(Q,T\)](#) [D2294UK](#) [405094E](#) [423220D](#) [MCH6646-TL-E](#) [TPCC8103,L1Q\(CM](#) [367-8430-0972-503](#) [VN1206L](#)
[424134F](#) [026935X](#) [051075F](#) [SBVS138LT1G](#) [614234A](#) [715780A](#) [NTNS3166NZT5G](#) [751625C](#) [873612G](#) [IRF7380TRHR](#)
[IPS70R2K0CEAKMA1](#) [RJK60S3DPP-E0#T2](#) [RJK60S5DPK-M0#T0](#) [APT5010JVFR](#) [APT12031JFLL](#) [APT12040JVR](#) [DMN3404LQ-7](#)
[NTE6400](#) [JANTX2N6796U](#) [JANTX2N6784U](#) [JANTXV2N5416U4](#) [SQM110N05-06L-GE3](#) [SIHF35N60E-GE3](#)