

发行日期 Date:	2018年12月25日 25.18, 2018
承认NO	GGST2018820

产 品 规 格 书

Product specification

产品名称： 铝电解电容器
Products Name: Aluminum Electrolytic capacitor
产品系列： CD286 系列
Products Series: CD286 Series
客户名 Customer:

南通江海电容器股份有限公司

Nantong Jianghai Capacitor Co.,Ltd

制 作 Designed	审 核 Checked	批 准 Approved
魏金京	何霄云	丁继华

客户承认栏 User recognition bar	
-------------------------------	--

地址： 江苏省南通市平潮镇通杨南路 79 号

ADD: NO.79, Tongyang South Road, Pingchao Town, Nantong City ,Jiangsu Province, P.R. China

TEL: 0086-0513-86726014

FAX: 0086-0513-86571812

P.C. 226361

E-MAIL: hxy@jianghai.com

SPEC LIST FOR CD286 SERIES

江海部品号 JH P/N	额定电压 U_R (V)	标称容量 CAP (μ F)	容量偏差 (%)	损耗角正切 $\text{tg } \delta$ (%, 20°C, 120Hz)	漏电流 LC (μ A, 20°C, 2min)	ESR (Ω , 20°C, 120Hz)	寿命 (Hr, 105°C)	Rip (m)
ECR1HGK100MFA050011	50	10	± 20	10	10	13.3	1000	

江海部品号说明 JH P/N:

E	C	R		1	C	G	K	2	2	1	M		F	A	0	6	3
Capacitor Type Code	Terminal Type Code		Rated Voltage Code (V)		Series Code		Capacitance Code (μ F)			Capacitance Tolerance Code (%)		Lead Form Code		Dimensi Code			
Electrolytic Capacitor	Radial	R	50	1H	CD286	GK	10	100		+20		M	Taping	FA	5x11.5		
										-20							

1.适用范围 Adapt Range

本产品规格书适用于南通江海电容器股份有限公司 CD286 型铝电解电容器产品。

This product specification is adapted to CD286 series Aluminum Electrolytic Capacitors produced by Nantong Jianghai Capacitor Co.,Ltd

2.使用温度范围 Operating Temperature Range:

-55~+105 °C

-55°C:最低下限温度 +105°C:最高上限温度

3.浪涌电压 Surge voltage

工作电压 (V) Rated voltage	6.3	10	16	25	35	50	63	100
浪涌电压 (V) Surge voltage	8	13	20	32	44	63	79	125

4.1 损耗 Dissipation Factor (20°C, 120Hz)

工作电压 (V) Rated voltage	6.3	10	16	25	35	50	63	100
损耗角正切值 Tan(%)MAX	22	19	16	14	12	10	9	8

When nominal capacitance is over 1000 μF, Tan shall be added 0.02 to the listed valued with increase of every 1000 μF

4.2 静电容量范围 Capacitance Range

0.47uF ~ 15000uF

5.表示 Marking

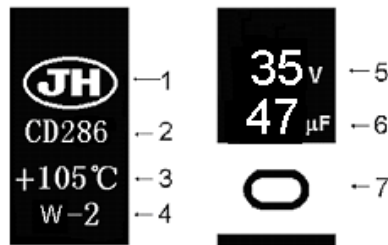

NO.	项 目 Item	NO.	项目 Item
1	商 标 Brand	5	额定电压 Rated voltage
2	产品系列 Products series	6	静电容量 Capacitance
3	上限温度: Max temperature	7	极 性 Polarity
4	年度标记 Year code		

6.外形图 Dimensions

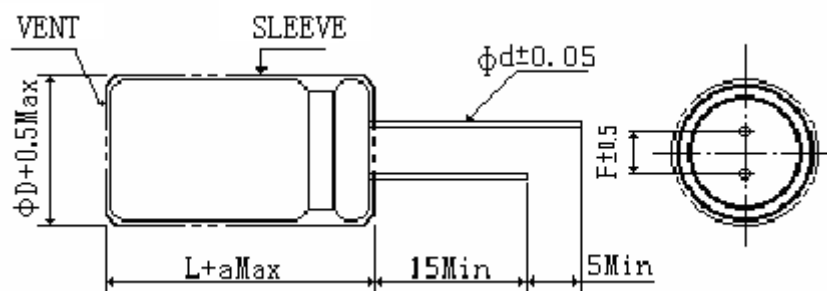

ΦD	5.0	6.3	8	10	12.5	16	18	20	20	22	25
F	2.0	2.5	3.5	5.0	5.0	7.5	7.5	7.5	10	10	12.5
Φd	0.5	0.5	0.6	0.6	0.6	0.8	0.8	0.8	0.8	1.0	1.0
α	1.0	1.0	1.0	2.0	2.0	2.0	2.0	2.0	2.0	2.5	2.5

7. 纹波电流系数 Multiplier for ripple current

7. 1 频率系数 Frequency Coefficients

Cap(μF) \ Freq(Hz)	120	1K	10K	100K
5.6~180	0.4	0.75	0.90	1.0
220~560	0.5	0.85	0.94	1.0
680~1800	0.6	0.87	0.95	1.0
2200~3900	0.75	0.90	0.95	1.0
4700~18000	0.85	0.95	0.98	1.0

7. 2 温度系数 Temperature Coefficients

温度 Temperature (°C)	+40	+60	+70	+85	+90	+95	+100	+105
系数 Coefficient	2.1	2.05	1.96	1.68	1.55	1.4	1.2	1.0

8. 构造图及材料表 (Frame drawing and Material list)

8. 1 构造图 (Frame drawing)

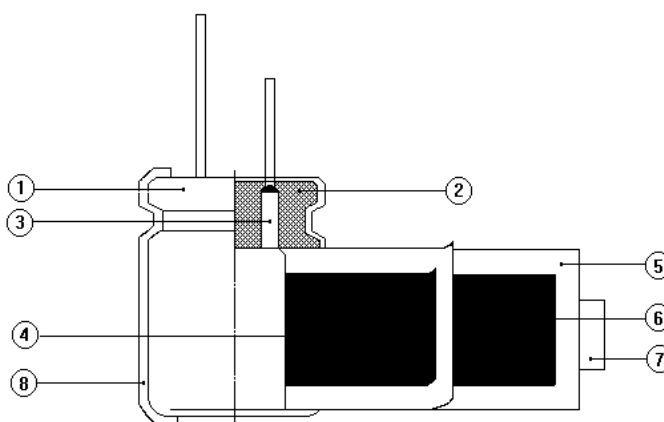

8. 2 材料表 (Material table)

NO	构成部件 parts	材质 Material	供应商 Supply Factory	NO	构成部件 parts	材质 Material	供应商 Supply Factory
1	铝壳 Case	铝 Aluminum	临安奥星、通州新联、联亿电子	6	负极箔 Cathode Foil	铝 Aluminum	K-JCC、佳信电子、吴江飞乐、万盛电子
2	橡皮塞 Rubber	合成橡胶 Synthetic rubber	浙江天台祥和、苏州毅丰、玉环鑫庄、东莞强安、小里机材、点创	7	胶带 Tape	聚丙烯 Polypropylene	日东电工、湖州润科、杭州和联
3	引出线 Terminal	铝+CP线 Aluminum + CP wire	南通全用电子、南通南鑫电子、欣宏	8	套管 Sleeve	PET	无等电子、苏州启联、顺鹏塑胶、嘉宾发
4	正极箔 Anode Foil	铝 Aluminum	宏远、华锋、海一、展成、JCC、KDK	9	电解液 Electrolyte	有机溶剂 Organic Solvent	江海电容器有限公司
5	隔离纸 Separator	电解电容器纸 Electrolytic Capacitors paper	NKK、日本大福造纸、嘉菲特、浙江凯恩、山东新凯电子				

9.性能特征:Specifications

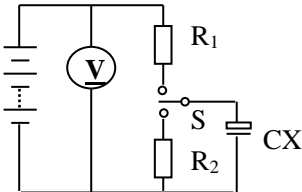
NO	项 目 Items	条 件 Conditions	规 格 Specifications
9.1	最大允许纹波电流 Maximum permissible ripple current	温度 Temperature : $105 \pm 2^{\circ}\text{C}$ 电压: 直流电压值+交流电压峰值 \leq 标称电压 . Voltage: DC. Voltage +peak ripple voltage \leq Rated voltage	见规格表 Refer to spec. list
9.2	浪涌电压 Surge Voltage	在下面规定的温度下,通过指定的浪涌电压,6.0分钟(充电30秒,放电5分30秒)为一周,往返1000回合,常温常湿下放置1~2小时达到热平衡状态测定满足 The capacitor shall be subjected to 1000 cycles at a temperature specified below, each consisting of a charge period of $30 \pm 5\text{s}$, followed by a discharge period of approx 5min.30 s. And the capacitor shall be stored 1~2 hours under standard atmospheric conditions to obtain thermal stability , after which measurement shall be made 应加电压: 见3项 Test voltage: see 3 温度: $15 \sim 30^{\circ}\text{C}$ Test Temperature : $15 \sim 30^{\circ}\text{C}$ 测试回路 Measurement circuit  R1: 串联保护电阻 ($1\text{K}\Omega$) Protective series resistor ($1\text{K}\Omega$) V: 直流电压表 DC Voltage R2: 放电电阻 Discharge resistor ($1\text{K}\Omega$) S: 切换开关 Switch Cx: 待测电容器 Test Capacitor	漏电流: 不超过规定值 Leakage Current: Not more than the specified value 容量变化: 初始值的 $\pm 15\%$ 以内 Capacitance change: Within $\pm 15\%$ of the initial value 损耗角正切: 不超过规定值 Dissipation Factor : Not more than the specified value κ
9.3	静电容量 (允许偏差) Capacitance (Tolerance)	测试频率: 120 Hz Measuring frequency : 120 Hz 测试电压: $0.5 V_{\text{rms}}$ or less Measuring voltage : $0.5 V_{\text{rms}}$ or less DC bias voltage : $+1.5 \sim 2.0 \text{ V DC}$	静电容量允许偏差 $\pm 20\%$ Capacitance Tolerance $\pm 20\%$
9.4	损耗角正切($\text{tg } \delta$) Dissipation Factor	测试条件与静电容量相同 Measurement shall be made under the same conditions as those given for the measurement of capacitance	见规格表 Refer to SPEC LIST

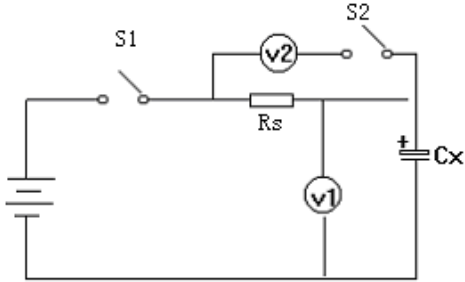
<p>9.5</p> <p>漏电流 Leakage Current</p>		<p>电容器接 $1000 \pm 10 \Omega$ 的保护电阻施加电压 1 或 2 分钟后的测试电流。 The rated voltage shall be applied across the capacitor and its protective resistor which shall be $1000 \pm 10 \Omega$. The leakage Current shall then be measured after an electrocution period of 2min. The leakage current shall be calculated by the following equation. 漏电流: $(I) = E/R_s$ Leakage current: E: 直流电压表的电压值 Voltage measured with DC voltmeter R_s:标准电阻的电阻值 Resistance of the protective resistor 测定电路 measurement circuit</p>  <p>电压将下法 voltage drop method) R_s:标准电阻的电阻值 ($1000 \pm 10 \Omega$) protective resistor 直流电压表或电子电压表 DC voltmeter or electronic voltmeter S1:开关 switch S2:电压表保护用变换开关 Protective switch for a voltmeter CX:待测电容器 test capacitor</p>	<p>0.02CV 或 3uA 以下(2 分钟取大值) Less than 0.02CV or 3uA whichever larger (2min) C: 标称静电容量 (μF) Capacitance V: 额定电压 (V) Rated voltage</p>
---	--	--	--

NO.	项目 Items	条 件 Conditions																														
9.6	高低温特性 Characteristic at High and low temperature	<p>电容器根据下表的次序处理 The capacitor shall be subjected in turn to the procedures specified below.</p> <table border="1" data-bbox="667 477 1409 842"> <thead> <tr> <th>阶段 Step</th> <th>温 度 Temperature</th> <th>时 间 Time</th> </tr> </thead> <tbody> <tr> <td>1</td> <td>20±2℃</td> <td>热平衡状态 Thermal equilibrium</td> </tr> <tr> <td>2</td> <td>-55±3℃</td> <td>*2 小时 2 hours</td> </tr> <tr> <td>3</td> <td>20±2℃</td> <td>热平衡状态 Thermal equilibrium</td> </tr> <tr> <td>4</td> <td>105±2℃</td> <td>*2 小时 2 hours</td> </tr> <tr> <td>5</td> <td>20±2℃</td> <td>热平衡状态 Thermal equilibrium</td> </tr> </tbody> </table> <p>* 电容器放置在每一温度下，待阻抗或电容量稳定后方可测试。 * The capacitor should be stored at each temperature until measured impedance or capacitance are stabilized .</p> <table border="1" data-bbox="667 992 1409 1391"> <thead> <tr> <th>阶段 2 Step 2</th> <th>阻抗比 (对阶段 1) Impedance ratio</th> <th>见 9.10 项 refer to No 9.10</th> </tr> </thead> <tbody> <tr> <td></td> <td>静电容量变化率 (对阶段 1) Change in capacitance</td> <td>静电 -20~0% within -20~0%</td> </tr> <tr> <td>阶段 4 Step 4</td> <td>静电容量变化率 (对阶段 1) Change in capacitance</td> <td>静电 0~+20% within 0~+20% of step 1</td> </tr> <tr> <td></td> <td>漏电流 Leakage Current</td> <td>规定值 5 倍以下 Less than 500% of the specified value</td> </tr> </tbody> </table> <p>阶段 1: 测定容量，损耗和阻抗值。 Step 1: Capacitance, Dissipation Factor and impedance shall be measured. 阶段 2: 放置 2 小时后，达到热平衡状态再测。 Step 2: After the capacitor being stored for 2 hours, Capacitance, Dissipation Factor and impedance shall be Measured. The measurement shall be made at thermal stability. 阶段 4: 放置 2 小时后，达到热平衡状态再测。 Step 4: After the capacitor being stored for 2 hours, Capacitance, Dissipation Factor and impedance shall be Measured. The measurement shall be made at thermal stability.</p>	阶段 Step	温 度 Temperature	时 间 Time	1	20±2℃	热平衡状态 Thermal equilibrium	2	-55±3℃	*2 小时 2 hours	3	20±2℃	热平衡状态 Thermal equilibrium	4	105±2℃	*2 小时 2 hours	5	20±2℃	热平衡状态 Thermal equilibrium	阶段 2 Step 2	阻抗比 (对阶段 1) Impedance ratio	见 9.10 项 refer to No 9.10		静电容量变化率 (对阶段 1) Change in capacitance	静电 -20~0% within -20~0%	阶段 4 Step 4	静电容量变化率 (对阶段 1) Change in capacitance	静电 0~+20% within 0~+20% of step 1		漏电流 Leakage Current	规定值 5 倍以下 Less than 500% of the specified value
阶段 Step	温 度 Temperature	时 间 Time																														
1	20±2℃	热平衡状态 Thermal equilibrium																														
2	-55±3℃	*2 小时 2 hours																														
3	20±2℃	热平衡状态 Thermal equilibrium																														
4	105±2℃	*2 小时 2 hours																														
5	20±2℃	热平衡状态 Thermal equilibrium																														
阶段 2 Step 2	阻抗比 (对阶段 1) Impedance ratio	见 9.10 项 refer to No 9.10																														
	静电容量变化率 (对阶段 1) Change in capacitance	静电 -20~0% within -20~0%																														
阶段 4 Step 4	静电容量变化率 (对阶段 1) Change in capacitance	静电 0~+20% within 0~+20% of step 1																														
	漏电流 Leakage Current	规定值 5 倍以下 Less than 500% of the specified value																														

No.	项目 Items	条件 Conditions	规格 Specifications														
9. 7	压力释放 Pressure relief	<p>一. 交流试验 A.C. test 施加电压值: Applied voltage 交流电压不超过 0.7 倍的额定直流电压或 250V 交流电压, 两者取小值。 A.C. voltage not exceeding 0.7 times the rated Direct voltage or 250V AC whichever is the lower. 频率 Frequency : 50 Hz 或 60 Hz 串联电阻参照下表 Series resistor refer to the table below.</p> <table border="1" data-bbox="596 640 1118 922"> <thead> <tr> <th>Capacitance</th> <th>Series resistor</th> </tr> </thead> <tbody> <tr> <td>$C \leq 1 \mu\text{F}$</td> <td>$1000 \pm 100 \Omega$</td> </tr> <tr> <td>$1 \mu\text{F} < C \leq 10 \mu\text{F}$</td> <td>$100 \pm 10 \Omega$</td> </tr> <tr> <td>$10 \mu\text{F} < C \leq 100 \mu\text{F}$</td> <td>$10 \pm 1 \Omega$</td> </tr> <tr> <td>$100 \mu\text{F} < C \leq 1000 \mu\text{F}$</td> <td>$1 \pm 0.1 \Omega$</td> </tr> <tr> <td>$1000 \mu\text{F} < C \leq 10000 \mu\text{F}$</td> <td>$0.1 \pm 0.01 \Omega$</td> </tr> <tr> <td>$10000 \mu\text{F} < C$</td> <td>*</td> </tr> </tbody> </table> <p>* 电阻相当于试验频率阻抗的 1/2 Resistance is equivalent to a half of Impedance by test frequency.</p> <p>二. 直流试验 D.C. test 施加同额定电压相等的反电压。 Reversed polarity D.C. rated voltage shall be applied to the capacitor.</p> <p>注: 1、该规定适用于铝壳直径 6mm 以上的电容器。 2、试验开始 30 Min 后, 防爆装置不动作时, 停止试验。</p> <p>Note: 1. This requirement applies to capacitors with a diameter of 6mm or more. 2. When the pressure relief device does not open even 30 minutes after commencement of this test, the test may be ended.</p>	Capacitance	Series resistor	$C \leq 1 \mu\text{F}$	$1000 \pm 100 \Omega$	$1 \mu\text{F} < C \leq 10 \mu\text{F}$	$100 \pm 10 \Omega$	$10 \mu\text{F} < C \leq 100 \mu\text{F}$	$10 \pm 1 \Omega$	$100 \mu\text{F} < C \leq 1000 \mu\text{F}$	$1 \pm 0.1 \Omega$	$1000 \mu\text{F} < C \leq 10000 \mu\text{F}$	$0.1 \pm 0.01 \Omega$	$10000 \mu\text{F} < C$	*	<p>防爆装置释放时, 无燃烧、无爆炸或铝壳和封口材料的分离。 The pressure relief device shall open in such a way as to avoid any danger of fire or explosion of Capacitor elements .</p>
Capacitance	Series resistor																
$C \leq 1 \mu\text{F}$	$1000 \pm 100 \Omega$																
$1 \mu\text{F} < C \leq 10 \mu\text{F}$	$100 \pm 10 \Omega$																
$10 \mu\text{F} < C \leq 100 \mu\text{F}$	$10 \pm 1 \Omega$																
$100 \mu\text{F} < C \leq 1000 \mu\text{F}$	$1 \pm 0.1 \Omega$																
$1000 \mu\text{F} < C \leq 10000 \mu\text{F}$	$0.1 \pm 0.01 \Omega$																
$10000 \mu\text{F} < C$	*																

No.	项目 Items	条 件 Conditions	规 格 Specifications																				
9.8	高温负荷 Load life	<p>在 105±2℃的恒温箱内, 电容器施加最大允许纹波电流, 施加直流电压和交流电压的峰值的和要等于额定电压, 时间 2000 小时。(Φ<8: 1000 小时), 试验结束后, 在标准状态下放置 16 小时后进行测试。</p> <p>The capacitor shall be placed in a circulating air oven at an ambient temperature of 105±2℃。 It must not be subjected to direct radiation from heating elements. DC voltage and the rated ripple current shown in table shall be applied for a period of 2000 hours[Φ 8<20000hrs]. The sum of the DC voltage and peak AC voltage must not exceed the full rated voltage of the capacitor. It shall be subjected to standard atmospheric for 16 hours, after which measurement shall be made.</p>	<p>漏电流: 不超过规定值 容量变化: 初测值的±20% 以内 损耗角正切: 不超过规定值的 2 倍</p> <p>Leakage current : ≤ Initial specified value Capacitance change :Within ± 20 % of initial value dissipation factor : ≤ 200% of initial specified value 试验后底部允许轻微鼓起: After test allow slight plump</p> <table border="1"> <thead> <tr> <th>壳号 (Φ)</th> <th>判定基准</th> </tr> </thead> <tbody> <tr> <td><12.5</td> <td>≤0.8mm</td> </tr> <tr> <td>12.5~16</td> <td>≤1.0mm</td> </tr> <tr> <td>18~22</td> <td>≤1.6mm</td> </tr> <tr> <td>25</td> <td>≤1.8mm</td> </tr> </tbody> </table>	壳号 (Φ)	判定基准	<12.5	≤0.8mm	12.5~16	≤1.0mm	18~22	≤1.6mm	25	≤1.8mm										
壳号 (Φ)	判定基准																						
<12.5	≤0.8mm																						
12.5~16	≤1.0mm																						
18~22	≤1.6mm																						
25	≤1.8mm																						
9.9	高温存储 Shelf life	<p>温度 Temp : 105±2℃ 时间 Time : 1000+36 小时 电压处理: 在常温下电容器串联保护电阻 (1KΩ), 加额定电压 30 分钟, 放电, 常温放置 24~ 48 小时后测量。</p> <p>Condition : The DC rated voltage shall be applied across the capacitor and its protective resistor (1KΩ) for 30 minutes, The capacitor shall then be stored under standard Atmospheric conditions for 24 ~ 48 hours. 若判定有疑义, 则按 JIS C5141 5.2 进行电压处理 if any doubt arises on the judgment ,the capacitors shall be subjected to voltage treatment specified in JIS C5141 5.2。</p>	<p>漏电流: 不超过规定值 容量变化: 初测值的±20% 以内 损耗角正切: 不超过规定值的 2 倍</p> <p>Leakage current : ≤ Initial specified value Capacitance change :Within ± 20 % of initial value dissipation factor : ≤ 200% of initial specified value</p>																				
9.10	阻抗特性 Impedance stability	<table border="1"> <thead> <tr> <th colspan="2">Rated voltage (V)</th> <th>6.3</th> <th>10</th> <th>16</th> <th>25</th> <th>35</th> <th>50</th> <th>63</th> <th>100</th> </tr> </thead> <tbody> <tr> <td>Impedance (120Hz)</td> <td>Z -55℃ /+20℃</td> <td colspan="8">3</td> </tr> </tbody> </table>	Rated voltage (V)		6.3	10	16	25	35	50	63	100	Impedance (120Hz)	Z -55℃ /+20℃	3								
Rated voltage (V)		6.3	10	16	25	35	50	63	100														
Impedance (120Hz)	Z -55℃ /+20℃	3																					
9.11	可焊性 Solder ability	<p>浸渍时间 Solder press time: 2±0.5s 焊接温度 Solder temperature: 235±5℃</p>	<p>浸渍面积 90% 以上附着 At least 90% of Circumferential surface of the dipped portion of termination shall be covered with new solder</p>																				
9.12	耐焊接热 Resistance to soldering heat	<p>温度: 260±5℃ Test Temperature: 260±5℃ 时间: 10±1 s Test time: 10±1s</p>	<p>漏电流: 不超过规定值 Leakage Current : Not more than the specified value 电容量变化: 初测值的±10% 以内 Capacitance change : within ± 10% of the initial value 损耗角正切: 不超过规定值 Dissipation Factor : Not more than the specified value 外观 Appearance : 无明显异常</p>																				

No.	项目 Items	条 件 Conditions	规 格 Specifications																														
9.13	耐湿性 Resistance of dump heat	温度: 40±2℃ Test Temperature : 40±2℃ 湿度: 90-95% RH Relative Humidity: 90-95%RH 时间: 240±8hrs Time: 240±8hrs 试验后常温放置 24-48 小时 To expose in the atmospheric condition for 24to 48 hours after completion of test	漏电流: 不超过规定值 Leakage Current :Not more than the specified value 电容量变化: 初测值的±10%以内 Capacitance Change :within ±10% of the initial value 损耗角正切: 不超过规定值 Dissipation factor :Not more than the specified value 外观 Appearance :无明显异常 No remarkable abnormality																														
9. 14	耐振性 Resistance to vibration	频率: 10-55-10 Hz/分 Frequency :From 10 to 55 Hz and return to 10 Hz, shall be transferred in 1 Min Total Amplitude: 1.5 mm 条件: X. Y. Z 方向各 2 小时 Direction and duration of vibration :3 orthogonal directions mutually each for 2 hours Total 6 hours .	静电容量测试时无接触不良, 断线及短路, 端子无机械损伤 Capacitance :During the test ,measured value to be stabilized (when measured several times within 30 min before completion of test)Appearance :No remarkable abnormality 静电容量变化: 初始值的±5%以内 Capacitance change: Within ±5% of the initial value 外观无明显异常 No remarkable abnormality																														
9.15	耐溶剂性 Resisting Solvent	方法一: 溶剂 Solvent: 异丙醇 Isopropyl alcohol 温度 Temperature: 20-25℃ 时间 Time: 30±5s 或方法二: 溶剂 Solvent: 软化水或蒸馏水 Demineralized or distilled Water 温度 Temperature: 50-60℃ 时间 Time: 300±30s	外观: 无显著异常 Appearance: No remarkable abnormality																														
9.16	端子强度 Terminal Strength	<table border="1"> <thead> <tr> <th>拉伸度 Tensile test intensity</th> <th>线径 Diameter of terminal (mm)</th> <th>拉伸力 Tensile Strength (N)</th> <th>维持时间 continued time</th> </tr> </thead> <tbody> <tr> <td rowspan="3"></td> <td>0.3<d≤0.5</td> <td>5</td> <td rowspan="3">10±1 sec</td> </tr> <tr> <td>0.5<d≤0.8</td> <td>10</td> </tr> <tr> <td>0.8<d≤1.25</td> <td>20</td> </tr> <tr> <th>弯曲强度 winding intensity</th> <th colspan="3">2 回合 2 bends</th> </tr> <tr> <td rowspan="3"></td> <th>线径 Diameter of terminal (mm)</th> <th>弯曲力 Tensile Strength (N)</th> <th>锥质量 Awl quality</th> </tr> <tr> <td>0.3<d≤0.5</td> <td>2.5</td> <td>0.25 kg</td> </tr> <tr> <td>0.5<d≤0.8</td> <td>5</td> <td>0.51 kg</td> </tr> <tr> <td></td> <td>0.8<d≤1.25</td> <td>10</td> <td>1.0 kg</td> </tr> </tbody> </table>	拉伸度 Tensile test intensity	线径 Diameter of terminal (mm)	拉伸力 Tensile Strength (N)	维持时间 continued time		0.3<d≤0.5	5	10±1 sec	0.5<d≤0.8	10	0.8<d≤1.25	20	弯曲强度 winding intensity	2 回合 2 bends				线径 Diameter of terminal (mm)	弯曲力 Tensile Strength (N)	锥质量 Awl quality	0.3<d≤0.5	2.5	0.25 kg	0.5<d≤0.8	5	0.51 kg		0.8<d≤1.25	10	1.0 kg	测定静电容量时, 无接触不良, 开路和短路现象, 另外无机械损伤和端子损伤。 When the capacitance is measured ,there shall be no intermittent contacts or open -or short -ciruiting . There shall be no such mechanical damage as terminal damage etc.
拉伸度 Tensile test intensity	线径 Diameter of terminal (mm)	拉伸力 Tensile Strength (N)	维持时间 continued time																														
	0.3<d≤0.5	5	10±1 sec																														
	0.5<d≤0.8	10																															
	0.8<d≤1.25	20																															
弯曲强度 winding intensity	2 回合 2 bends																																
	线径 Diameter of terminal (mm)	弯曲力 Tensile Strength (N)	锥质量 Awl quality																														
	0.3<d≤0.5	2.5	0.25 kg																														
	0.5<d≤0.8	5	0.51 kg																														
	0.8<d≤1.25	10	1.0 kg																														

No.	项目 Items	条 件 Conditions	规 格 Specifications
9.17	温度循环 Temperature cycle	1) 低温: $-40^{+0}_{-3}^{\circ}\text{C}$ Low Temp: $-40^{+0}_{-3}^{\circ}\text{C}$ 2) 高温: $+105^{+3}_{-0}^{\circ}\text{C}$ High Temp: $+105^{+3}_{-0}^{\circ}\text{C}$ 3) Cycle 数: 100 回 Cycle :100 Cycle 4) 维持时间: 各阶段 30 分钟 Times: 30mins each step 若判定有疑义, 则按 JIS C5101-4 4.1 进行电压处理 If any doubt arises on the judgment ,the capacitors shall be subjected to voltage treatment specified in JISC5101-4 4.1	漏电流: 不超过规定值 Leakage Current :Not more than the specified value 电容量变化: 初测值的 $\pm 15\%$ 以内 Capacitance Change :within $\pm 15\%$ of the initial value 损耗角正切: 不超过规定值 Dissipation Factor :Not more than the specified value 外观无明显异常 Appearance :No remarkable abnormality

10. 编带 Lead Taping

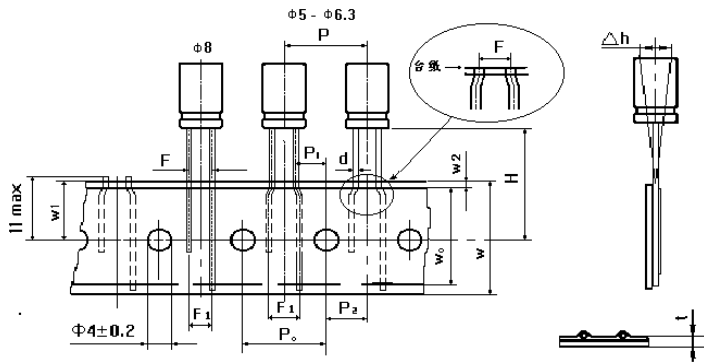

壳号 尺寸	φ5	φ6.3	φ8
CODE	FA	FA	FA
F +0.8/ -0.2	2.0	2.5	3.5
H +0.75/ -0.5	18.5	18.5	18.5
F1 ±1.0	3.5	3.5	3.5
P ±1.0	12.7	12.7	12.7
P0 ±0.2	12.7	12.7	12.7
P1 ±0.5	5.35	5.1	4.6
P2 ±0.5	6.35	6.35	6.35
W ±0.5	18.0	18.0	18.0
W0	10.0 以上	10.0 以上	10.0 以上
W1 ±0.5	9.0	9.0	9.0
W2 (max)	1.5	1.5	1.5
t ±0.2	0.7	0.7	0.7

Fig 4

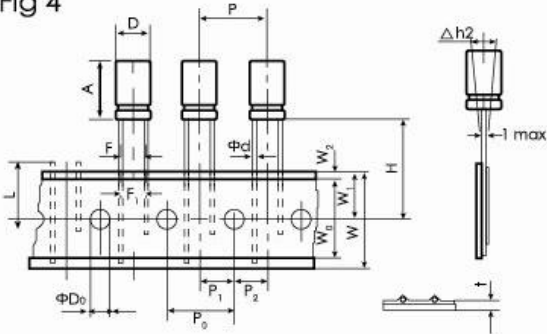
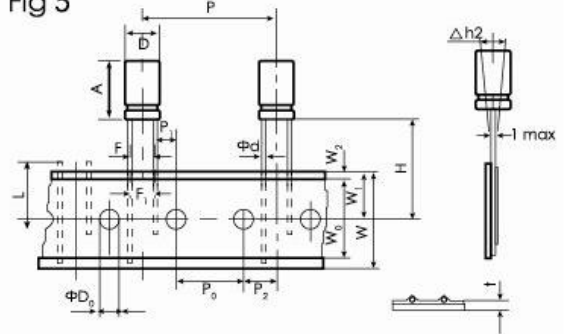

Fig 5



Item	φD	A	φd	P	P0	P1	P2	F	F1	W	W0	W1	W2	H	H0	L	φD0	Δh2	t	Fig.	Taping Code
tol.	+0.5 max		± 0.05	± 1.0	± 0.2	± 0.5	± 1.0	+0.8 -0.2	± 1.0	± 0.5	min	± 0.5	max	+0.75 -0.5	± 0.5	max	± 0.5	max	± 0.2		
Nominal	10	12.5-25 (+2.0)	0.6	12.7	12.7	3.85	6.35	5	5	18.0	12.0	9.0	1.5	18.5	-	11.0	4.0	1.0	0.7	4	FA
	12.5	20-25 (+2.0)	0.6	15	15	5.0	7.5	5	5	18.0	12.0	9.0	1.5	18.5	-	11.0	4.0	1.0	0.7	4	FA
				25.4	12.7	3.85	6.35													5	FD
	16	20-25.5 (+2.0)	0.8	30	15	3.75	7.5	7.5	7.5	18.0	12.0	9.0	1.5	18.5	-	11.0	4.0	1.0	0.7	5	FD
18	20-25.5 (+2.0)	0.8	30	15	3.75	7.5	7.5	7.5	18.0	12.0	9.0	1.5	18.5	-	11.0	4.0	1.0	0.7	5	FD	

南通江海电容器股份有限公司

11. 编带包装 Taping packing

11.1 内外盒尺寸及数量 Size and Quantity of inbox and outbox

$\phi D \times L$	内盒 inbox				外盒 outbox			
	$W \pm 5$	$L \pm 5$	$H \pm 3$	Quantity (PCS)	$A \pm 5$	$B \pm 5$	$C \pm 3$	Quantity (PCS)
5×7	230	330	45	2000	345	500	250	20000
6.3×7	230	330	45	1500	345	500	250	15000
8×7	245	330	44	1000	350	520	270	10000
8×9	245	330	44	1000	350	520	270	10000
5×11.5	230	330	45	2000	345	500	250	20000
5×15	175	340	55	1500	360	615	200	15000
6.3×11.5	230	330	45	1500	345	500	250	15000
6.3×14	220	330	50	1500	350	480	270	15000
6.3×15	220	330	50	1500	350	480	270	15000
8×11.5	245	330	50	1000	345	540	270	10000
8×12	245	330	50	1000	345	540	270	10000
8×14	245	330	50	1000	345	540	270	10000
8×15	190	340	58	800	356	408	260	6400
8×16	190	340	58	800	356	408	260	6400
8×20	190	340	58	800	356	408	260	6400
10×12.5	190	340	50	500	356	408	225	4000
10×16	190	340	50	500	356	408	225	4000
10×20	190	340	58	500	356	408	260	4000
10×25	190	340	58	500	356	408	260	4000
10×30	190	340	68	500	356	408	295	4000
12.5×20	220	325	62	400	235	340	335	2000
12.5×25	220	325	62	400	235	340	335	2000
12.5×30	225	345	63	500	240	358	270	2000
16×20	225	345	63	250	240	358	270	1000
16×25	225	345	63	250	240	358	270	1000
16×30	218	345	68	250	230	358	295	1000
16×31.5	218	345	68	250	230	358	295	1000
18×35.5	275	345	73	250	290	358	330	1000
18×36	275	345	73	250	290	358	330	1000
18×40	275	345	78	250	290	358	330	1000

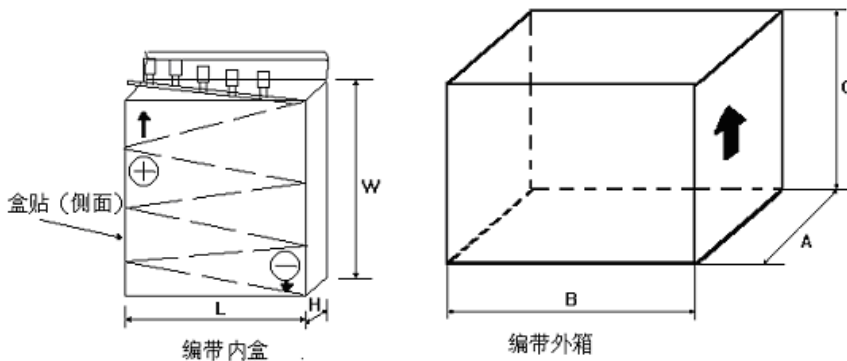

12.我公司目前生产的产品已经满足欧盟 RoHS 指令规定的标准，具体江海禁用限用物质标准如下：

Jianghai products have meet the RoHS directive standards, specific jianghai disable restricted substances as standard

序号	禁用物质名称 Name of prohibited substances	最大含量标准 Maximum content standard (PPM or mg/kg)	备注 remarking
1	Cadmium and -compounds (镉及其化合物)	5	
2	Mercury and -compounds (汞及其化合物)	2	
3	Pb and compounds (铅及其化合物)	90	
4	Cr VI (六价铬)	75	
5	PBBEs, poly brominated biphenyl ethers (聚溴化苯醚) /PBDE	10	
6	PBBs, poly brominated biphenyl (聚溴化苯)	10	
7	PCBs, poly chlorinated biphenyl (聚氯化苯)	10	
8	PCTs, poly chlorinated terphenyls (聚氯烃)	10	
9	PCP, Pentachlorophenol (五氯酚)	10	
10	All types Asbestos (所有类型石棉)	10	
11	CFCS, Chlorofluorocarbons (氟氯化碳)	0	
12	HCFCs, Hydrogenated chlorofluorocarbons (加氢氟氯化碳)	0	
13	CHCs, Chlorinated hydrocarbons (氯烃化合物)	0	
对于所供产品的包装材料还需满足下列标准：For the packaging materials for products, need to meet the following criteria:			
14	Cadmium, Mercury, Lead and Chromium VI (镉、汞、铅和铬的总和)	100	参考 94/62/EC Reference 94/62/EC
15	PVC and PVC blends (PVC 和 PVC 混合物)	1000	
补充要求：此标准未列明的其它重金属和化学物质含量标准以各个国家为准； Additional requirements: This standard does not indicate any other heavy metals and chemical substance content standards to all countries subject;			

* 欧盟 RoHS 指令规定的豁免不在上面标准之内。

RoHS exemption under the EU directive is not within the above criteria

* 环保物料定义：满足上述标准，并且已经无铅化；

Environmentally friendly materials Definition: meet the above criteria, and have been lead-free;

* 参考文件：94/62/EC(包装材料与包装废气物指令)、2002/95/EC(RoHS 指令)、

91/157/EEC(电池及蓄电池标准)、91/338/EEC(镉含量指令)、EN71-3(欧盟玩具重金属标准)

References: 94/62/EC (packaging material and packaging waste are Directive), 2002/95/EC (RoHS Directive), 91/157/EEC (the standard battery and battery), 91/338/EEC (cadmium content of instruction), EN71-3 (EU toy heavy metal standards)

二. 本公司符合欧盟 ROHS 指令的产品在电性能、尺寸方面没有任何改变，在焊接工艺方面没有任何要求，贵公司可以继续采用原有含铅焊接工艺。

Our company is in compliance with the European Union ROHS directive in electric products, no change. In the soldering process, without any requirements of your company can continue using the original lead-based welding technology.

13. 应用指南 Application Guidelines

13-1. Circuit Design

(1) Please make sure the application and mounting conditions to which the capacitor will be exposed are within the conditions specified in the catalog or alternate product specification (Referred as to specification here after).

(2) Operating temperature and applied ripple current shall be within the specification. The capacitor shall not be used in an ambient temperature which exceeds the operating temperature specified in the specification. Do not apply excessive current which exceeds the allowable ripple current.

(3) Appropriate capacitors which comply with the life requirement of the products should be selected when designing the circuit.

(4) Aluminum electrolytic capacitors are polarized. Make sure that no reverse voltage or AC voltage is applied to the capacitors. Please use bi-polar capacitors for a circuit that can possibly see reversed polarity.

Note: Even bi-polar capacitors can not be used for AC voltage application.

(5) For a circuit that repeats rapid charging/discharging of electricity, an appropriate capacitor that is capable of enduring such a condition must be used. Welding machines and photoflash are a few examples of products that contain such a circuit. In addition, rapid charging/discharging may be repeated in control circuits for servomotors, in which the circuit voltage fluctuates substantially. For appropriate choice of capacitors for circuit that repeat rapid charging/discharging, please consult us.

(6) For conductive polymer solid capacitors, the leakage current may become greater even if the soldering conditions adhere to the specification requirements. Therefore, do not use such capacitors in the following circuits because trouble or failure may occur.

a) High impedance circuits

b) Coupling circuits

c) Time constant circuits

d) Do not use the capacitors in circuits except those above if changes in the leakage current affects circuit operations.

(7) It is said that to restrain output ripple current, the output smoothing capacitor of the switching power supply is suitable to use the smaller ESR capacitor. However when the

13-1, 电路设计

(1) 首先, 请确定电容器的使用和安装条件是否(必须)符合样本所供选择的产品规格中所规定的条件;

(2) 工作温度和施加的纹波电流必须符合规范中的要求。

电容器使用时的环境温度不能超过产品规格中规定的工作温度

施加的纹波电流不得超过允许值

(3) 在设计电路时, 必须选择符合其使用寿命要求的合适的电容器

(4) 铝电解电容器是有极性的, 因此要确保不对电容器施加反向电压或交流电压, 在可能会出现反向电压的场合, 建议使用双极性电容器。

注意: 即使是双极性电容器, 也不能应用在使用交流电压的场合。

(5) 对于需要反复充放电的电路而言, 那就必须使用能承受这种工作环境的合适电容器。像焊接机、闪光灯等设备当中就有这样的电路。此外, 在诸如伺服电机等控制电路中, 会出现反复的快速充放电, 电路中的电压波动很大。因此如要选择反复快速充放电电路中用合适电容器, 请与我们联系。

(6) 导电性高分子型固体铝电解电容器在电路使用中由于焊接等原因会导致漏电流增大, 因此不推荐应用于以下电路。

a) 高阻抗电路

b) 耦合电路

c) 时间常数电路

d) 受漏电流影响较大的电路

(7) 选用开关电源的输出平滑电容器时, 为了抑制输出纹波电压, 所选用电容器的等效串联电阻(ESR)越小越好, 然而使用 ESR 小

low ESR capacitor is used, the phenomenon sometimes occurs that is called the abnormal oscillation of output voltage.

30 degrees to 40 degrees or more of Phase margin is thought as a necessity to inhibit the oscillation of output voltage with a general negative feed-back circuit. The Phase margin is numerical value how much the minimum value of the Phase is distant from -180 degrees. The smaller the Phase margin gets, the higher the possibility to oscillate by the characteristic dispersion and temperature change of the component will be.

By doing Phase compensation with the feed-back circuit of the error amplifier the oscillation of output voltage can be inhibited.

(8) Make sure that no excess voltage (that is, higher than the rated voltage) is applied to the capacitor.

Please pay attention so that the peak voltage, which is DC voltage overlapped by ripple current, will not exceed the rated voltage.

In the case where more than 2 aluminum electrolytic capacitors are used in series, please make sure that applied voltage will be lower than rated voltage and the voltage will be applied to each capacitor equally using a balancing resistor in parallel with the capacitors.

(9) Outer sleeve of the capacitor is not guaranteed as an electrical insulator. Do not use a standard sleeve on a capacitor in applications that require the electrical insulation. When the application requires special insulation, please contact our sales office for details.

(10) Capacitors may fail if they are used under the following conditions:

① Environmental (climatic) conditions

a. Being exposed to water, high temperature & high humidity atmosphere, or condensation of moisture.

b. Being exposed to oil or an atmosphere that is filled with particles of oil.

c. Being exposed to salty water or an atmosphere that is filled with particles of salt.

d. In an atmosphere filled with toxic gasses (such as hydrogen sulfide, sulfurous acid, nitrous acid, chlorine, bromine, methyl bromide, ammonia, etc.)

e. Being exposed to direct sunlight, ozone, ultraviolet ray, or radiation

f. Being exposed to acidic or alkaline solutions

② Under severe conditions where vibration and/or mechanical shock exceed the applicable ranges of the specifications.

的电容器有可能发生输出电压的异常振荡。

为防止输出电压发生振荡，在一般负反馈线路上，相位需要留有 30~40 度以上的余量。相位的余量是指相位的下限值至 -180 度的数值，相位的余量越小，构件的性能差及温度变化引起振荡的可能性越大。

通过利用误差放大器反馈线路的相位修正，可以防止输出电压的振荡。

(8) 确保电容器不能在过压状态下工作（即高于额定电压）

请注意峰值电压，即由直流电压叠加纹波电流的电压，不能超过额定电压；

在要串联使用 2 个以上电容器的场合，施加的电压要低于额定电压，并用一个均衡电阻与电容器并联，使电压平均地施加到每个电容器上。

(9) 电容器外面的套管不能保证做绝缘之用，所以在需要将其作为电绝缘的应用场合，这些电容器不能使用一般标准的套管。假如你的应用场合需要特殊绝缘的话，请与我们的销售部联系了解详细情况。

(10) 在下列条件下使用的电容器很可能会导致失效

① 环境条件

a. 接触水，高温高湿度气候，或易产生冷凝水的地方；

b. 接触油，或充满油气的地方；

c. 接触盐水，或充满盐尘的地方；

d. 含有有毒气体的场合（如盐酸、硫酸、硝酸、氯、溴、甲基溴、氨等）；

e. 直接暴露在有阳光、臭氧、紫外线或辐射的环境中；

f. 接触酸碱溶液。

② 在震动或机械冲击超过指标规定范围的那些恶劣环境下

<p>(11) When designing a P.C. board, please pay attention to the following:</p> <p>①Have the hole spacing on the P.C. board match the lead spacing of the capacitor.</p> <p>②There should not be any circuit pattern or circuit wire above the capacitor pressure relief vent.</p> <p>③ Unless otherwise specified, following clearance should be made above the pressure relief vent.</p> <table border="1" data-bbox="296 555 922 698"> <thead> <tr> <th>Case Diameter</th> <th>Clearance Required</th> </tr> </thead> <tbody> <tr> <td>6.3~16mm</td> <td>2mm or more</td> </tr> <tr> <td>18~35mm</td> <td>3mm or more</td> </tr> <tr> <td>40mm or more</td> <td>5mm or more</td> </tr> </tbody> </table> <p>④In case the vent side is placed toward P.C. board (such as end seal vented parts), make a corresponding hole on the P.C. board to release the gas when vent is operated. The hole should be made to match the capacitor vent position.</p> <p>⑤Screw terminal capacitors must be installed with their end seal side facing up. When you install a screw terminal capacitor in a horizontal position, the positive terminal must be in the upper position.</p> <p>(12) The main chemical solution of the electrolyte and the separator paper used in the capacitors are combustible. The electrolyte is conductive. When it comes in contact with the P.C. board, there is a possibility of pattern corrosion or short circuit between the circuit pattern which could result in smoking or catching fire. Do not locate any circuit pattern beneath the capacitor end seal.</p> <p>(13) Do not design a circuit board so that heat generating components are placed near an aluminum electrolytic capacitor or reverse side of P.C. board (under the capacitor).</p> <p>(14) Electrical characteristics may vary depending on changes in temperature and frequency. Please consider this variation when you design circuits.</p> <p>(15) When you mount capacitors on the double-sided P.C. boards, do not place capacitors on circuit patterns or over on unused holes.</p> <p>(16) The torque for terminal screw or brackets screws shall be within the specified value in specifications.</p> <p>(17) When you install more than 2 capacitors in parallel, consider the balance of current flowing through the capacitors.</p>	Case Diameter	Clearance Required	6.3~16mm	2mm or more	18~35mm	3mm or more	40mm or more	5mm or more	<p>(11) 当在设计印刷线路板时, 请注意下列事项:</p> <p>①电路板上的开孔间距必须与电容器引线的间距相匹配;</p> <p>②在电容器的防爆阀上方, 不应有任何电路走线图形或导线;</p> <p>③除非另有规定, 否则防爆上方应留出下列间隙:</p> <table border="1" data-bbox="922 510 1497 667"> <thead> <tr> <th>外壳直径</th> <th>须留间隙</th> </tr> </thead> <tbody> <tr> <td>Φ6.3~16mm</td> <td>≥2mm</td> </tr> <tr> <td>Φ18~35mm</td> <td>≥3mm</td> </tr> <tr> <td>40 或 40mm 以上</td> <td>≥5mm</td> </tr> </tbody> </table> <p>④如果防爆阀是朝着印刷线路板方向的(例如防爆阀在盖板上的电容器), 则要在线路板上相应的开一个孔, 可使阀打开后的气体排出。这个孔必须对准电容器防爆的位置</p> <p>⑤安装螺丝终端电容器时, 必须将装盖板的面朝上。当水平方向安装螺丝终端电容器时, 必须将正极终端放在上面。</p> <p>(12) 电解液中使用的化学溶液和电容器中的电解纸都是易燃品, 而且电解液是导电的, 一旦它与电路板接触, 就有可能造成电路板上的走线图形腐蚀, 或走线图形之间的短路, 最终导致冒烟或起火。</p> <p>(13) 在设计线路板时, 在其正反两面上均不要让电容器靠近发热元件;</p> <p>(14) 电性能的改变与温度和频率有关, 所以在设计电路时要考虑这些变化因素;</p> <p>(15) 当在双面线路板上安装电容器时, 要让开线路图形和还未使用的插孔;</p> <p>(16) 终端螺丝或支架螺丝的力矩应符合规格书上规定的值;</p> <p>(17) 当你并联安装 2 个以上电容器时, 要考虑流经电容器的电流的平衡, 特别是当并联固体聚合物铝电解电容器和标准的铝电解电容器时, 要给予这方面特别的考虑;</p>	外壳直径	须留间隙	Φ6.3~16mm	≥2mm	Φ18~35mm	≥3mm	40 或 40mm 以上	≥5mm
Case Diameter	Clearance Required																
6.3~16mm	2mm or more																
18~35mm	3mm or more																
40mm or more	5mm or more																
外壳直径	须留间隙																
Φ6.3~16mm	≥2mm																
Φ18~35mm	≥3mm																
40 或 40mm 以上	≥5mm																

Especially, When a solid conductive polymer aluminum electrolytic capacitor and a standard aluminum electrolytic capacitor are conected in parallel, special consideration must be given.

(18) If more than 2 aluminum electrolytic capacitors are used in series, make sure the applied voltage will be lower than the rated voltage and that voltage will be applied to each capacitor equally using a balancing resistor in parallel with each capacitor.

13-2. Mounting

(1) Once a capacitor has been assembled in the set and power applied, Even if a capacitor is discharged, an electric potential(recovery voltage) may exist between the terminals.

(2) Electric potential between positive and negative terminal may exist as a result of returned electromotive force, so please discharge the capacitor using a 1 k resistor.

(3) Leakage current of the parts that have been stored for more than 1 year may increase. If leakage current has increased, please perform a voltage treatment using 1 k resistor.

(4) Please confirm ratings before installing capacitors on the P.C. board.

(5) Please confirm polarity before installing capacitors on the P.C. board.

(6) Do not drop capacitors on the floor, nor use a capacitor that was dropped.

(7) Do not damage the capacitor while installing.

(8) Please confirm that the lead spacing of the capacitor matches the hole spacing of the P.C. board prior to installation.

(9) Snap-in type capacitor should be installed tightly to the P.C. board (allow no gap between the P.C. board and bottom of the capacitor).

(10) Please pay attention that the clinch force is not too strong when capacitors are placed and fixed by an automatic insertion machine.

(11) Please pay attention to that the mechanical shock to the capacitor by suction nozzle of the automatic insertion machine or automatic mounter, or by product checker, or by centering mechanism.

(12) Hand soldering.

①Soldering condition shall be confirmed to be within the specification.

②If it is necessary that the leads must be

(18) 如果串联使用 2 个以上的电容器时, 要确保施加的电压小于额定电压, 并要采用一个与每个电容器并联的均衡电阻使该电压均匀地施加到每个电容器上。

13-2 安装

(1) 一旦电容器装上机器, 并接通电源, 即使电容器已放过电, 但是在两个终端之间仍存在一个电位差 (再生电压);

(2) 正极和负极之间的电位差也可能是由返回的电动势所造成的, 所以一定要用一只 1K 电阻实施放电;

(3) 存放 1 年以后的电容器漏电流可能会增加, 如果漏电流增大了, 请用一只 1K 电阻进行电压处理;

(4) 在把电容器装上电路板之前, 请首先确认一下其额定值;

(5) 在把电容器装上电路板前, 请对极性进行确认;

(6) 不要让电容器掉落到地板上, 也不能使用掉到地板上的电容器;

(7) 安装时千万不能损坏电容器;

(8) 安装之前确认一下电容器引线间距是否与线路板的孔距相匹配;

(9) 焊片式电容器要紧靠线路板安装 (电容器的底部和线路板之间不留间隙);

(10) 当用自动插件机安装和固定电容器时, 请注意夹持力不能太大;

(11) 请注意由自动插件机或产品检查仪或中心定位机所产生的振动对电容器的影响;

(12) 手工焊接

①焊接条件必须符合规范的要求;

②如果由于引线间距和线路板上的孔距不匹配需要引线成型的话, 则必须在焊接前弯好引线, 而不能对电容器施加太多的应力;

formed due to a mismatch of the lead space to hole space on the board, bend the lead prior to soldering without applying too much stress to the capacitor.

③If you need to remove parts which were soldered, please melt the solder enough so that stress is not applied to lead.

④Please pay attention so that solder iron does not touch any portion of capacitor body.

(13) Flow soldering (Wave solder)

① Aluminum capacitor body must not be submerged into the solder bath. Aluminum capacitors must be mounted on the "top side" of the P.C. board and only allow the bottom side of the P.C. board to come in contact with the solder.

②Soldering condition must be confirmed to be within specification.

Solder temperature: $260 \pm 5^{\circ}\text{C}$, Immersing lead time: 10 ± 1 second, Thickness of P.C. board : 1.6mm.

③Please avoid having flux adhere to any portion except the terminal.

④ Please avoid contact between other components and the aluminum capacitor.

(14) Reflow soldering (SMD only)

①Soldering condition must be confirmed to be within specification.

Pre-heating : Less than 150°C , 90 seconds max. Max. temperature at capacitor top during reflow : 230°C

The duration for over 200°C temperature at capacitor top: 20 seconds max.

The duration from the pre-heat temperature to peak temperature of reflow varies due to changes of the peak temperature.

②When an infrared heater is used, please pay attention to the extent of heating since the absorption rate of infrared, will vary due to difference in the color of the capacitor body, material of the sleeve and capacitor size.

③ The number of reflow time for SMT aluminum electrolytic capacitors shall be one time. If this type of capacitor has to be inevitably subjected to the reflow twice, enough cooling time between the first and second reflow (at least more than 30 minutes) shall be taken to avoid consecutive reflow. Please contact us if you have questions.

(15) Soldering flux

There are non-halogen types of flux that do not contain ionic halides, but contain many

③如需要拆下焊好的电容器,则要让焊锡充分熔化,使引线不受任何应力;

④ 请注意不能让烙铁接触电容器本体;

(13) 波峰焊

①电容器本体不能浸入锡缸,铝电解电容器必须装在线路板的上面,只允许线路板的反面与焊锡接触;

②焊接条件必须符合规格书规定的指标值:焊锡温度小于 $260 \pm 5^{\circ}\text{C}$, 引线浸没时间小于 10 ± 1 秒, 线路板厚度不小于 1.6mm

③除了终端外,其他部分均不能沾上助焊剂

④ 要防止电容器与其他元器件接触

(14) 回流焊

①焊接条件必须符合规格书规定的指标值:预热: 小于 150°C , 最多 90 秒; 回流焊过程中电容器顶部的最高温度为 230°C , 在电容器顶部超过 200°C 的时间最多为 20 秒; 从预热温度到回流焊峰值温度的时间随峰值温度的改变而变化。

②使用红外加热器时,应注意加热的程度,因为电容器本体的颜色,套管材料和电容器大小等方面的差异会使红外线的吸收率产生变化;

③表面贴装用铝电解电容器能承受的回流焊次数是一次,如果这种电容器一定要进行第二次回流焊的话,那么在第一次和第二次回流焊之间要有足够的冷却时间(至少 30 分钟以上),不能连续进行回流。如有问题请与我们联系。

(15) 焊锡、助焊剂

有不含离子卤化物而含有许多非离子卤化物的非卤型助焊剂,当这些非离子卤化物渗入电容器之后会引起一种化学反应,其结果就会象使用了清洁剂一样对电容器造成损害,所以要采用不含非离子卤化物

<p>non-ionic halides. When these non-ionic halides infiltrate the capacitor, they cause a chemical reaction that is just as harmful as the use of cleaning agents. Use soldering flux that does not contain non-ionic halides.</p> <p>(16) Do not tilt lay down or twist the capacitor body after the capacitors are soldered to the P.C. board.</p> <p>(17) Do not carry the P.C. board by grasping the soldered capacitor.</p> <p>(18) Please do not allow anything to touch the capacitor after soldering. If P.C. board are stored in a stack, please make sure P.C. board or the other components do not touch the capacitor. The capacitors shall not be effected by any radiated heat from the soldered P.C. board or other components after soldering.</p> <p>13-3. In the equipment</p> <p>(1) Do not directly touch terminal by hand.</p> <p>(2) Do not short between terminals with conductor, nor spill conductible liquid such as alkaline or acidic solution on or near the capacitor.</p> <p>(3) Please make sure that the ambient conditions where the set is installed will be free from spilling water or oil, direct sunlight, ultraviolet rays, radiation, poisonous gases, vibration or mechanical shock.</p> <p>13-4. Maintenance Inspection</p> <p>Please periodically inspect the aluminum capacitors that are installed in industrial equipment. The following items should be checked:</p> <p>① Appearance : Remarkable abnormality such as vent operation, leaking electrolyte etc.</p> <p>② Electrical characteristic: Capacitance, dielectric loss tangent, leakage current, and items specified in the specification.</p> <p>13-5. In an Emergency</p> <p>(1) If you see smoke due to operation of safety vent, turn off the main switch or pull out the plug from the outlet.</p> <p>(2) Do not bring your face near the capacitor when the pressure relief vent operates. The gasses emitted from that are over 100°C. If the gas gets into your eyes, please flush your eyes immediately in pure water.</p>	<p>的助焊剂。</p> <p>(16) 电容器焊到线路板上之后，不要将电容器倾倒或扭曲。</p> <p>(17) 拿线路板时，不要抓住焊好的电容器。</p> <p>(18) 不要让焊好的电容器碰到其他任何东西。如果要将线路板堆放储存的话，要确保线路板或其他元件不要碰到电容器。电容器不能受焊好的线路板或其他焊好的元器件的热辐射影响。</p> <p>13-3.设备中</p> <p>(1) 不要用手直接接触电容器的终端</p> <p>(2) 不要用导体在两个终端之间进行短路，也不能把诸如酸碱溶液等导电液体泼近或泼到电容器上。</p> <p>(3) 要确保安装设备的环境条件要远离水、油、阳光的直接照射，紫外线、辐射、有毒气体、振动或机械冲击。</p> <p>13-4. 保养检查</p> <p>请定期检查安装在工业设备中的铝电解电容器必须检查下列内容</p> <p>① 外观, : 是否有明显的异常, 如防爆阀打开, 漏液等;</p> <p>② 电性能: 容量, $\text{tg}\delta$、漏电流和规范中规定的项目</p> <p>13-5. 在紧急情况下</p> <p>(1) 如果你看到防爆阀打开后冒出的烟雾, 请立即关掉电源, 将插头从插座上拔下。</p> <p>(2) 当防爆阀打开时, 不要将脸凑近电容器, 因为从里面散发出来的气体温度可达 100 °C 以上, 如果气体冲进你眼睛的话, 请立即用纯水冲洗眼睛。 如果吸入这种气体的话, 请马上用水清洗眼睛和喉咙。 请不要咽下电解液, 如果皮肤接</p>
---	--

If you breathe the gas, immediately wash out your mouth and throat with water.
Do not ingest electrolyte. If your skin is exposed to electrolyte, please wash it away using soap and water.

13-6. Storage

(1) It is recommended to keep capacitors between the ambient temperatures of 5°C to 35°C and a relative humidity of 75% or below.

(2) Confirm that the environment does not have any of the following conditions:

① Where capacitors are exposed to water, high temperature & high humidity atmosphere, or condensation of moisture.

② Where capacitors are exposed to oil or an atmosphere that is filled with particles of oil.

③ Where capacitors are exposed to salty water, high temperature & high humidity atmosphere, or condensation of moisture.

④ The atmosphere is filled with toxic acid gasses (e.g. hydrogen sulfide, sulfurous acid, nitrous acid, chlorine, bromine, methy bromide, etc.)

⑤ The atmosphere is filled with toxic alkaline gasses (e.g. ammonia)

⑥ Where capacitors are exposed to acidic or alkaline solutions.

5) Storage Term: 2years after delivered.

(6) The handling method for products exceeding the term of validity

Leakage current of the parts that have been stored for more than 2 year may increase. If leakage current has increased, please perform a voltage treatment using 1 k resistor.

13-7. Disposal

Take either of the following methods in disposing of capacitors.

Make a hole in the capacitor body or crush capacitors and incinerate them.

If incineration is not applicable, hand them over to a waste disposal agent and have them buried in a landfill.

触到了电解液，请用水和肥皂将它洗净。

13-6. 储存

(1) 建议将电容器储存在 5 ~35 °C 和相对湿度小于 75% 的环境中。

(2) 确认储存环境中不会出现下列情况:

① 有水，高温高湿或有水凝结

② 接触油，或充满油污气

③ 有盐水，高温高湿，或有水凝结

④ 空气中含有毒酸气（如硫化氢、硫酸、亚硝酸、氯、溴、甲基溴等）

⑤ 空气中含有毒碱气（如氨）

⑥ 电容器置于酸碱溶液中。

(5) 保管期限：我司出库后 2 年。

(6) 超期处理

超期后一般漏电流会上升，在使用前进行电压处理。

13-7. 废弃处理

电容器的废弃处理可采用下列任何一种方法进行:

在电容器壳体上打个孔或将其敲碎后焚烧掉，如果焚烧不可行的话，请将这些电容器交给废品处理代理商找地方埋掉。

14、电气特性 Electrical behavior

电容器的电气特性与温度，时间，以及印加电压的关系

Characteristics of electrical capacitors vary wity temperature, time, and applied voltage.

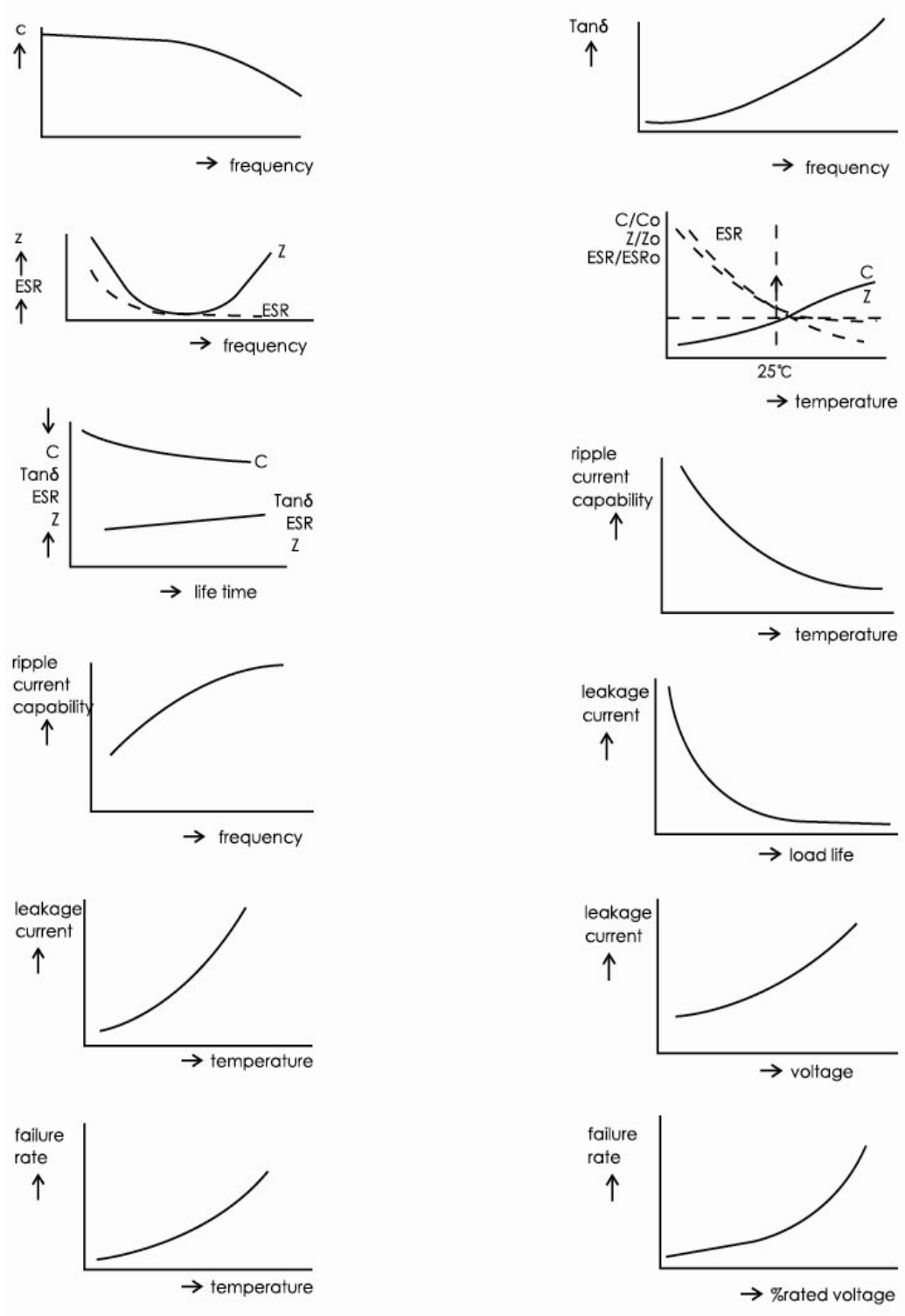

X-ON Electronics

Largest Supplier of Electrical and Electronic Components

Click to view similar products for [Aluminium Electrolytic Capacitors - Radial Leaded](#) category:

Click to view products by [Jianghai](#) manufacturer:

Other Similar products are found below :

[NRELS102M35V16X16C.140LLF](#) [ESRG160ETC100MD07D](#) [227RZS050M](#) [335CKR250M](#) [476CKH100MSA](#) [477CKR100M](#)
[107CKR010M](#) [107CKH063MSA](#) [RJH-25V222MI9#](#) [RJH-35V221MG5#](#) [B43827A1106M8](#) [RJH-50V221MH6#](#) [EKYA500ELL470MF11D](#)
[B41022A5686M6](#) [ESRG250ELL101MH09D](#) [EKMA160EC3101MF07D](#) [RJB-10V471MG3#](#) [ESMG160ETD221MF11D](#)
[EKZH160ETD152MJ20S](#) [RJH-35V122MJ6#](#) [EGXF630ELL621ML20S](#) [RBD-25V100KE3#N](#) [EKMA350ELL100ME07D](#)
[ESMG160ETD101ME11D](#) [ELXY100ETD102MJ20S](#) [EGXF500ELL561ML15S](#) [EKMG350ETD471MJ16S](#) [35YXA330MEFC10X12.5](#)
[RXW471M1ESA-0815](#) [ELXZ630ELL221MJ25S](#) [ERR1HM1R0D11OT](#) [LPE681M30060FVA](#) [LPL471M22030FVA](#) [HFE221M25030FVA](#)
[LKMD1401H221MF](#) [B41888G6108M000](#) [EKMA160ETD470MF07D](#) [UHW1J102MHD6](#) [EKMG500ETD221MJC5S](#) [LKMK2502W101MF](#)
[LKMD1401H181MF](#) [LKMI2502G820MF](#) [LKMJ2001J122MF](#) [LKML2501C472MF](#) [LKMJ4002C681MF](#) [450MXH330MEFCSN25X45](#)
[450MXK330MA2RFC22X50](#) [63ZLH560MEFCG412.5X30](#) [ELH2DM331O25KT](#) [ELH2DM471P30KT](#)