



## JST16 Series 16A TRIACs

Rev.3.0

### DESCRIPTION:

JST16 series triacs, with high ability to withstand the shock loading of large current, provide high dv/dt rate with strong resistance to electromagnetic interface. With high commutation performances, 3 quadrants products especially recommended for use on inductive load. JST16A provides insulation voltage rated at 2500V RMS and JST16F provides insulation voltage rated at 2000V RMS from all three terminals to external heatsink complying with UL standards (File ref: E252906).

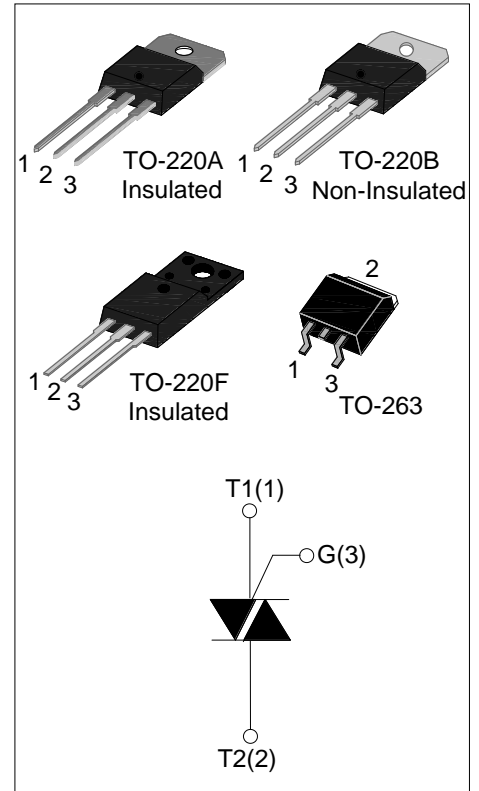

### MAIN FEATURES

Symbol	Value	Unit
$I_{T(RMS)}$	16	A
$V_{DRM}/V_{RRM}$	600 and 800 and 1200	V

### ABSOLUTE MAXIMUM RATINGS

Parameter		Symbol	Value	Unit
Storage junction temperature range		$T_{stg}$	-40-150	°C
Operating junction temperature range		$T_j$	-40-125	°C
Repetitive peak off-state voltage ( $T_j=25^\circ\text{C}$ )		$V_{DRM}$	600/800/1200	V
Repetitive peak reverse voltage ( $T_j=25^\circ\text{C}$ )		$V_{RRM}$	600/800/1200	V
Non repetitive surge peak Off-state voltage		$V_{DSM}$	$V_{DRM} + 100$	V
Non repetitive peak reverse voltage		$V_{RSM}$	$V_{RRM} + 100$	V
RMS on-state current	TO-220A(Ins) ( $T_C=86^\circ\text{C}$ )	$I_{T(RMS)}$	16	A
	TO-220B(Non-Ins) ( $T_C=107^\circ\text{C}$ )			
	TO-220F(Ins) ( $T_C=90^\circ\text{C}$ )			
	TO-263 ( $T_C=115^\circ\text{C}$ )			
Non repetitive surge peak on-state current (full cycle, F=50Hz)		$I_{TSM}$	160	A

I <sup>2</sup> t value for fusing (tp=10ms)	I <sup>2</sup> t	128	A <sup>2</sup> s
Critical rate of rise of on-state current (I <sub>G</sub> =2×I <sub>GT</sub> )	di/dt	50	A/μs
Peak gate current	I <sub>GM</sub>	4	A
Average gate power dissipation	P <sub>G(AV)</sub>	1	W
Peak gate power	P <sub>GM</sub>	5	W

**ELECTRICAL CHARACTERISTICS** (T<sub>j</sub>=25°C unless otherwise specified)

3 Quadrants (V<sub>DRM</sub>/V<sub>RRM</sub>: 600/800V)

Symbol	Test Condition	Quadrant		JST16-600/800V				Unit
				BW	CW	SW	TW	
I <sub>GT</sub>	V <sub>D</sub> =12V R <sub>L</sub> =33Ω	I - II -III	MAX	50	35	10	5	mA
V <sub>GT</sub>		I - II -III	MAX	1.5				V
V <sub>GD</sub>	V <sub>D</sub> =V <sub>DRM</sub> T <sub>j</sub> =125°C R <sub>L</sub> =3.3KΩ	I - II -III	MIN	0.2				V
I <sub>L</sub>	I <sub>G</sub> =1.2I <sub>GT</sub>	I -III	MAX	70	50	25	15	mA
		II		80	60	30	20	
I <sub>H</sub>	I <sub>T</sub> =100mA		MAX	60	40	25	15	mA
dV/dt	V <sub>D</sub> =2/3V <sub>DRM</sub> Gate Open T <sub>j</sub> =125°C		MIN	1000	500	100	50	V/μs
(dV/dt) <sub>c</sub>	(di/dt) <sub>c</sub> =1.7A/ms T <sub>j</sub> =125°C		MIN	14	8.5	6	5	V/μs

4 Quadrants (V<sub>DRM</sub>/V<sub>RRM</sub>: 600/800V)

Symbol	Test Condition	Quadrant		JST16-600/800V		Unit
				B	C	
I <sub>GT</sub>	V <sub>D</sub> =12V R <sub>L</sub> =33Ω	I - II -III	MAX	50	25	mA
		IV		70	50	
V <sub>GT</sub>		ALL	MAX	1.5		V
V <sub>GD</sub>	V <sub>D</sub> =V <sub>DRM</sub> T <sub>j</sub> =125°C R <sub>L</sub> =3.3KΩ	ALL	MIN	0.2		V
I <sub>L</sub>	I <sub>G</sub> =1.2I <sub>GT</sub>	I -III-IV	MAX	70	50	mA
		II		100	80	
I <sub>H</sub>	I <sub>T</sub> =100mA		MAX	60	40	mA

dV/dt	$V_D=2/3V_{DRM}$ Gate Open $T_j=125^\circ\text{C}$	MIN	500	200	V/ $\mu\text{s}$
(dV/dt) <sub>c</sub>	(dI/dt) <sub>c</sub> =1.7A/ms $T_j=125^\circ\text{C}$	MIN	8.5	6	V/ $\mu\text{s}$

3 Quadrants ( $V_{DRM}/V_{RRM}$ : 1200V)

Symbol	Test Condition	Quadrant		JST16-1200V	Unit
$I_{GT}$	$V_D=12\text{V}$ $R_L=33\Omega$	I - II -III	MAX	50	mA
$V_{GT}$		I - II -III	MAX	1.5	V
$V_{GD}$	$V_D=V_{DRM}$ $T_j=125^\circ\text{C}$ $R_L=3.3\text{K}\Omega$	I - II -III	MIN	0.25	V
$I_L$	$I_G=1.2I_{GT}$	I -III	MAX	70	mA
		II		80	
$I_H$	$I_T=100\text{mA}$		MAX	60	mA
dV/dt	$V_D=2/3V_{DRM}$ Gate Open $T_j=125^\circ\text{C}$		MIN	1500	V/ $\mu\text{s}$
(dV/dt) <sub>c</sub>	(dI/dt) <sub>c</sub> =1.7A/ms $T_j=125^\circ\text{C}$		MIN	14	V/ $\mu\text{s}$

**STATIC CHARACTERISTICS**

Symbol	Parameter		Value(MAX)			Unit
			-600V	-800V	-1200V	
$V_{TM}$	$I_{TM}=22.5\text{A}$ $t_p=380\mu\text{s}$	$T_j=25^\circ\text{C}$	1.55			V
$I_{DRM}$	$V_D=V_{DRM}$ $V_R=V_{RRM}$	$T_j=25^\circ\text{C}$	5	5	10	$\mu\text{A}$
$I_{RRM}$		$T_j=125^\circ\text{C}$	2	2	1	mA

**THERMAL RESISTANCES**

Symbol	Parameter		Value	Unit
$R_{th(j-c)}$	junction to case(AC)	TO-220A(Ins)	3.9	$^\circ\text{C}/\text{W}$
		TO-220B(Non-Ins)	1.2	
		TO-220F(Ins)	3.3	
		TO-263	0.85	

ORDERING INFORMATION

<p>JieJie Microelectronics Co.,Ltd</p>	<p><b>J</b></p>	<p><b>ST</b></p> <p>Triacs</p> <p><math>I_{T(RMS)}:16A</math></p> <p>E:TO-263</p> <p>A:TO-220A(Ins)</p> <p>F:TO-220F(Ins)</p> <p>B:TO-220B(Non-Ins)</p>	<p><b>16</b></p>	<p><b>A</b></p>	<p><b>-600</b></p> <p>600:<math>V_{DRM}/V_{RRM} \geq 600V</math></p> <p>800:<math>V_{DRM}/V_{RRM} \geq 800V</math></p> <p>1200:<math>V_{DRM}/V_{RRM} \geq 1200V</math></p>	<p><b>BW</b></p> <p>BW:<math>I_{GT3} \leq 50mA</math></p> <p>CW:<math>I_{GT3} \leq 35mA</math></p> <p>SW:<math>I_{GT3} \leq 10mA</math></p> <p>TW:<math>I_{GT3} \leq 5mA</math></p> <p>B:<math>I_{GT3} \leq 50mA</math> <math>I_{GT4} \leq 70mA</math></p> <p>C:<math>I_{GT3} \leq 25mA</math> <math>I_{GT4} \leq 50mA</math></p>
--	-----------------	---	------------------	-----------------	--	---

PACKAGE MECHANICAL DATA

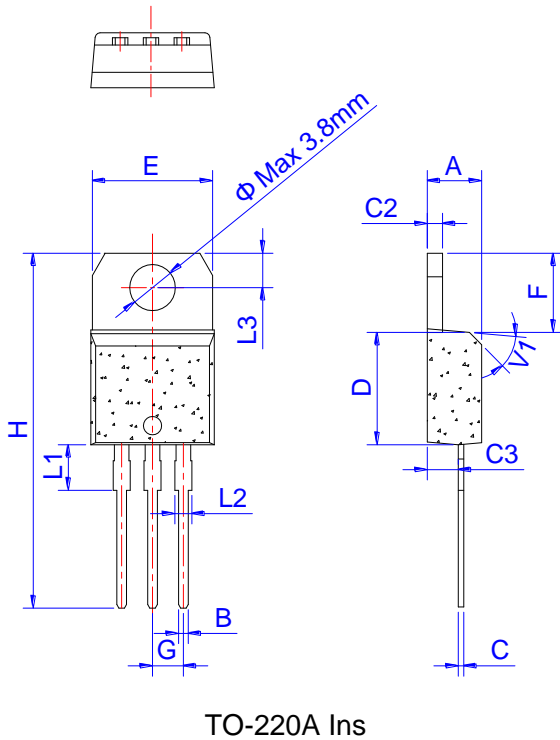

Ref.	Dimensions					
	Millimeters			Inches		
	Min.	Typ.	Max.	Min.	Typ.	Max.
A	4.40		4.60	0.173		0.181
B	0.61		0.88	0.024		0.035
C	0.46		0.70	0.018		0.028
C2	1.21		1.32	0.048		0.052
C3	2.40		2.72	0.094		0.107
D	8.60		9.70	0.339		0.382
E	9.80		10.4	0.386		0.409
F	6.55		6.95	0.258		0.274
G		2.54			0.1	
H	28.0		29.8	1.102		1.173
L1		3.75			0.148	
L2	1.14		1.70	0.045		0.067
L3	2.65		2.95	0.104		0.116
V1		45°			45°	

PACKAGE MECHANICAL DATA

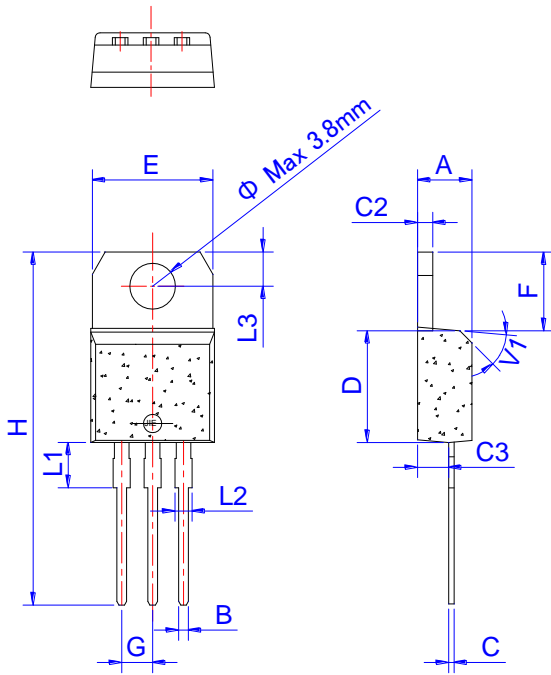

Ref.	Dimensions					
	Millimeters			Inches		
	Min.	Typ.	Max.	Min.	Typ.	Max.
A	4.40		4.60	0.173		0.181
B	0.61		0.88	0.024		0.035
C	0.46		0.70	0.018		0.028
C2	1.21		1.32	0.048		0.052
C3	2.40		2.72	0.094		0.107
D	8.60		9.70	0.339		0.382
E	9.60		10.4	0.378		0.409
F	6.20		6.60	0.244		0.260
G		2.54			0.1	
H	28.0		29.8	1.102		1.173
L1		3.75			0.148	
L2	1.14		1.70	0.045		0.067
L3	2.65		2.95	0.104		0.116
V1		45°			45°	

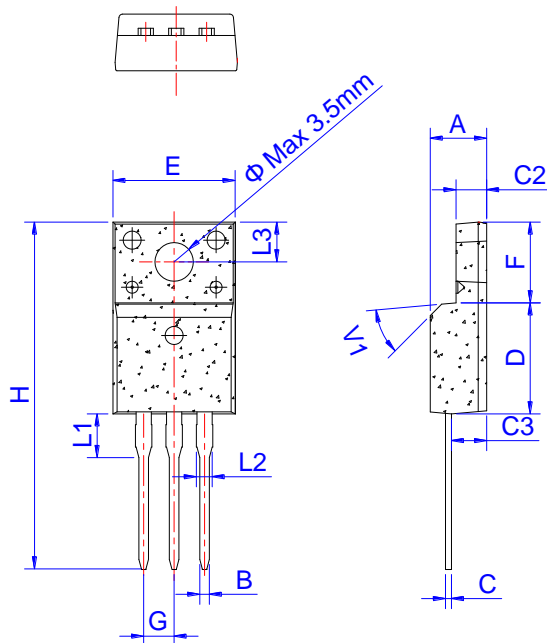

Ref.	Dimensions					
	Millimeters			Inches		
	Min.	Typ.	Max.	Min.	Typ.	Max.
A	4.40		4.80	0.173		0.189
B	0.74	0.80	0.83	0.029	0.031	0.033
C	0.48		0.75	0.019		0.030
C2	2.40		2.70	0.094		0.106
C3	2.60		3.00	0.102		0.118
D	8.80		9.30	0.346		0.366
E	9.70		10.3	0.382		0.406
F	6.40		7.00	0.252		0.276
G		2.54			0.1	
H	28.0		29.8	1.102		1.173
L1		3.63			0.143	
L2	1.14		1.70	0.045		0.067
L3		3.30			0.130	
V1		45°			45°	

PACKAGE MECHANICAL DATA

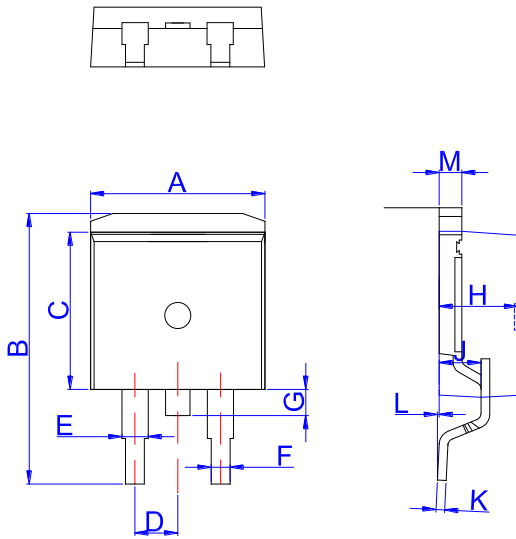

TO-263

Ref.	Dimensions					
	Millimeters			Inches		
	Min.	Typ.	Max.	Min.	Typ.	Max.
A	9.90		10.20	0.390		0.402
B	14.70		15.80	0.579		0.622
C	9.4		9.6	0.37		0.378
D		2.54			0.100	
E	1.20		1.40	0.047		0.055
F	0.75		0.85	0.029		0.033
G			1.75			0.069
H	4.40		4.70	0.173		0.185
J	2.30		2.70	0.091		0.106
K	0.38		0.55	0.015		0.022
L	0	0.10	0.25	0	0.004	0.010
M	1.25		1.35	0.049		0.053

FIG.1 Maximum power dissipation versus RMS on-state current

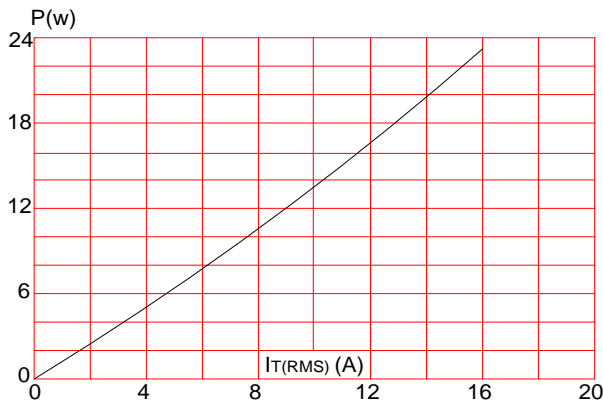

FIG.3: Surge peak on-state current versus number of cycles

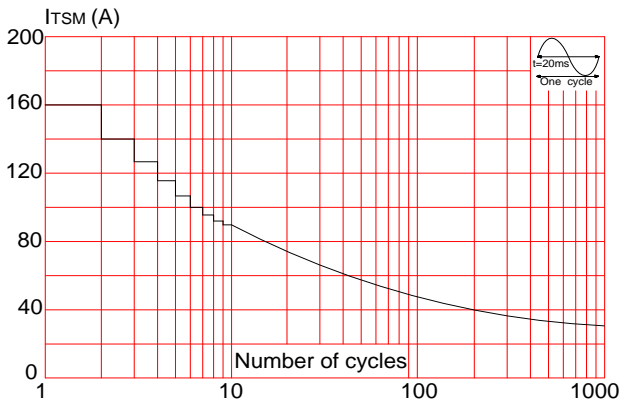

FIG.2: RMS on-state current versus case temperature

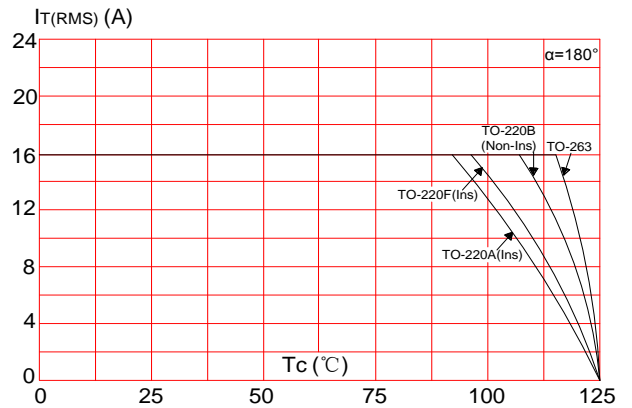
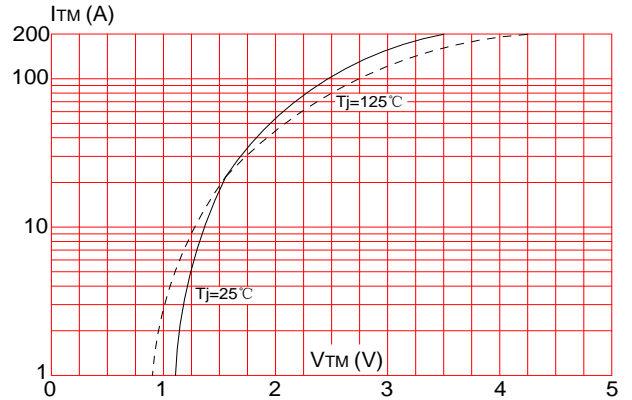
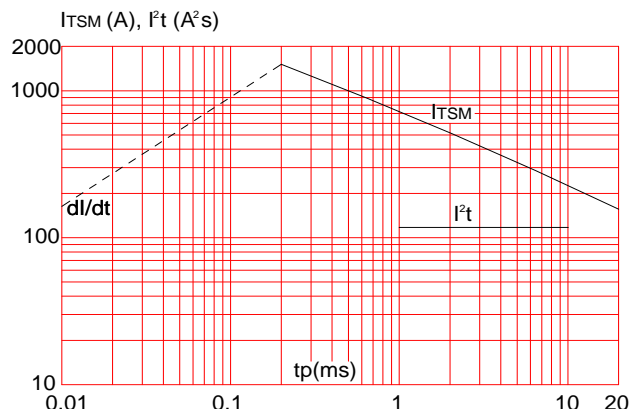

FIG.4: On-state characteristics (maximum values)



**FIG.5:** Non-repetitive surge peak on-state current for a sinusoidal pulse with width  $t_p < 20\text{ms}$ , and corresponding value of  $I^2t$  ( $di/dt < 50\text{A}/\mu\text{s}$ )



**FIG.6:** Relative variations of gate trigger current, holding current and latching current versus junction temperature

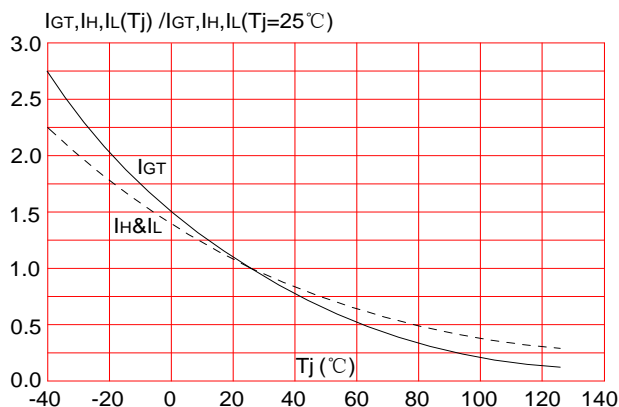

Information furnished in this document is believed to be accurate and reliable. However, Jiangsu JieJie Microelectronics Co.,Ltd assumes no responsibility for the consequences of use without consideration for such information nor use beyond it.

Information mentioned in this document is subject to change without notice, apart from that when an agreement is signed, Jiangsu JieJie complies with the agreement.

Products and information provided in this document have no infringement of patents. Jiangsu JieJie assumes no responsibility for any infringement of other rights of third parties which may result from the use of such products and information.

This document is the third version which is made in 9-June-2015. This document supersedes and replaces all information previously supplied.

 is a registered trademark of Jiangsu JieJie Microelectronics Co.,Ltd.

Copyright ©2015 Jiangsu JieJie Microelectronics Co.,Ltd. Printed All rights reserved.

## X-ON Electronics

Largest Supplier of Electrical and Electronic Components

*Click to view similar products for [Triacs](#) category:*

*Click to view products by [JieJie](#) manufacturer:*

Other Similar products are found below :

[BT137-600-0Q](#) [OT415Q](#) [2N6075A](#) [NTE5688](#) [BTA2008W-800D,135](#) [D31410](#) [BT136-600,127](#) [BT137B-800,118](#) [BTA140-600,127](#)  
[BTA208-800B,127](#) [MAC97A6,116](#) [BTA420-800BT,127](#) [BTA201W-800E,115](#) [BTA212B-800B,118](#) [BTA26-800CW3G](#) [BTA41-800BRG](#)  
[TMA164P-L](#) [TMA166P-L](#) [TMA54S-L](#) [BT137-600E,127](#) [BTA140-800,127](#) [BTA30-600CW3G](#) [BTB16-600CW3G](#) [TMA84S-L](#)  
[Z0109MN,135](#) [T825T-6I](#) [T1635T-6I](#) [T1220T-6I](#) [NTE5638](#) [ACST1235-8FP](#) [BT134-600D,127](#) [BT134-600G,127](#) [BT136X-600E,127](#)  
[BT139X-800,127](#) [BTA204X-800C,127](#) [BTA216-600E,127](#) [BTA316X-600E/DG,12](#) [BTA316X-800C,127](#) [BT134-600D,127](#) [BT134-600E,127](#)  
[BT137X-600D,127](#) [BT139X-600E,127](#) [BTA08-600BW3G](#) [BTA201-800ER,126](#) [BTA208X-1000B,127](#) [BTA316X-800E,127](#) [NTE56008](#)  
[NTE56017](#) [NTE56018](#) [NTE56059](#)