



## JST41 Series 40A TRIACs

Rev.4.0

### DESCRIPTION:

JST41 series triacs, with high ability to withstand the shock loading of large current, provide high dv/dt rate with strong resistance to electromagnetic interface. With high commutation performances, 3 quadrants products especially recommended for use on inductive load.

JST41Z provides insulation voltage rated at 2500V RMS from all three terminals to external heatsink complying with UL standards (File ref: E252906).

### MAIN FEATURES

Symbol	Value	Unit
$I_{T(RMS)}$	40	A
$V_{DRM}/V_{RRM}$	600 and 800 and 1200 and 1600	V

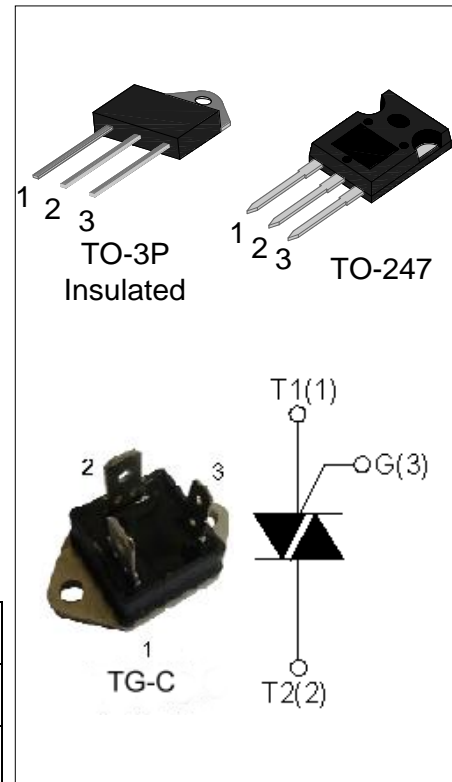

### ABSOLUTE MAXIMUM RATINGS

Parameter		Symbol	Value	Unit
Storage junction temperature range		$T_{stg}$	-40-150	°C
Operating junction temperature range		$T_j$	-40-125	°C
Repetitive peak off-state voltage ( $T_j=25^\circ\text{C}$ )		$V_{DRM}$	600/800/1200/1600	V
Repetitive peak reverse voltage ( $T_j=25^\circ\text{C}$ )		$V_{RRM}$	600/800/1200/1600	V
Non repetitive surge peak Off-state voltage		$V_{DSM}$	$V_{DRM} + 100$	V
Non repetitive peak reverse voltage		$V_{RSM}$	$V_{RRM} + 100$	V
RMS on-state current	TO-3P(Ins) ( $T_C=80^\circ\text{C}$ )	$I_{T(RMS)}$	40	A
	TO-247/ TG-C ( $T_C=90^\circ\text{C}$ )			
Non repetitive surge peak on-state current (full cycle, $F=50\text{Hz}$ )		$I_{TSM}$	400	A
$I^2t$ value for fusing ( $t_p=10\text{ms}$ )		$I^2t$	880	$\text{A}^2\text{s}$
Critical rate of rise of on-state current ( $I_G=2 \times I_{GT}$ )		$di/dt$	50	$\text{A}/\mu\text{s}$

Peak gate current	$I_{GM}$	4	A
Average gate power dissipation	$P_{G(AV)}$	1	W
Peak gate power	$P_{GM}$	10	W

**ELECTRICAL CHARACTERISTICS** ( $T_j=25^{\circ}\text{C}$  unless otherwise specified)

3 Quadrants

Symbol	Test Condition	Quadrant		Value	Unit
$I_{GT}$	$V_D=12\text{V } R_L=33\Omega$	I - II -III	MAX	50	mA
$V_{GT}$		I - II -III	MAX	1.3	V
$V_{GD}$	$V_D=V_{DRM} T_j=125^{\circ}\text{C}$ $R_L=3.3\text{K}\Omega$	I - II -III	MIN	0.2	V
$I_L$	$I_G=1.2I_{GT}$	I -III	MAX	80	mA
		II		100	
$I_H$	$I_T=100\text{mA}$		MAX	60	mA
dV/dt	$V_D=2/3V_{DRM}$ Gate Open $T_j=125^{\circ}\text{C}$		MIN	1000	V/ $\mu\text{s}$
(dV/dt)c	Without snubber $T_j=125^{\circ}\text{C}$		MIN	20	V/ $\mu\text{s}$

4 Quadrants

Symbol	Test Condition	Quadrant		Value	Unit
$I_{GT}$	$V_D=12\text{V } R_L=33\Omega$	I - II -III	MAX	50	mA
		IV		70	
$V_{GT}$		ALL	MAX	1.5	V
$V_{GD}$	$V_D=V_{DRM} T_j=125^{\circ}\text{C}$ $R_L=3.3\text{K}\Omega$	ALL	MIN	0.2	V
$I_L$	$I_G=1.2I_{GT}$	I -III-IV	MAX	90	mA
		II		100	
$I_H$	$I_T=100\text{mA}$		MAX	80	mA
dV/dt	$V_D=2/3V_{DRM}$ Gate Open $T_j=125^{\circ}\text{C}$		MIN	500	V/ $\mu\text{s}$
(dV/dt)c	Without snubber $T_j=125^{\circ}\text{C}$		MIN	30	V/ $\mu\text{s}$

**STATIC CHARACTERISTICS**

Symbol	Parameter		Value(MAX)	Unit
$V_{TM}$	$I_{TM}=60A$ $t_p=380\mu s$	$T_j=25^\circ C$	1.55	V
$I_{DRM}$	$V_D=V_{DRM}$ $V_R=V_{RRM}$	$T_j=25^\circ C$	10	$\mu A$
$I_{RRM}$		$T_j=125^\circ C$	5	mA

**THERMAL RESISTANCES**

Symbol	Parameter		Value	Unit
$R_{th(j-c)}$	junction to case(AC)	TO-3P(Ins)	0.9	$^\circ C/W$
		TO-247/ TG-C	0.8	

**ORDERING INFORMATION**

JieJie Microelectronics Co.,Ltd	<b>J</b> Triacs $I_{T(RMS)}:40A$	<b>ST</b>	<b>41</b>	<b>Z</b> Z:TO-3P(Ins) S:TO-247 T:TG-C	<b>-600</b>	<b>BW</b> BW: $I_{GT3}\leq 50mA$ B: $I_{GT1-3}\leq 50mA$ $I_{GT4}\leq 70mA$ 600: $V_{DRM}/V_{RRM}\geq 600V$ 800: $V_{DRM}/V_{RRM}\geq 800V$ 1200: $V_{DRM}/V_{RRM}\geq 1200V$ 1600: $V_{DRM}/V_{RRM}\geq 1600V$
---------------------------------	--	-----------	-----------	---	-------------	---

PACKAGE MECHANICAL DATA

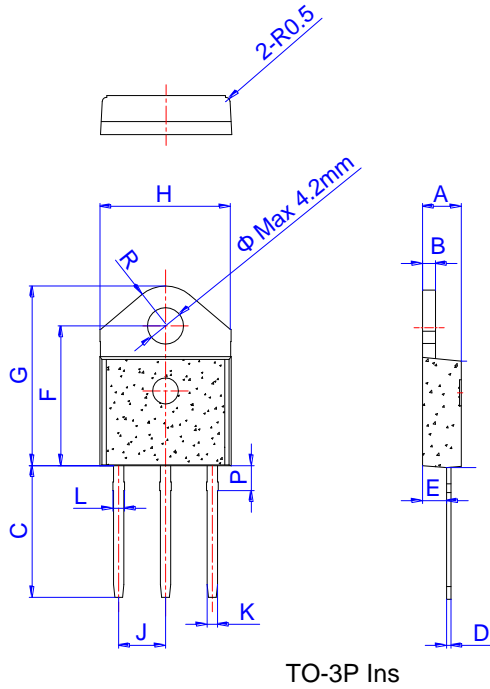

Ref.	Dimensions					
	Millimeters			Inches		
	Min.	Typ.	Max.	Min.	Typ.	Max.
A	4.40		4.60	0.173		0.181
B	1.45		1.55	0.057		0.061
C	14.35		15.60	0.565		0.614
D	0.50		0.70	0.020		0.028
E	2.70		2.90	0.106		0.114
F	15.80		16.50	0.622		0.650
G	20.40		21.10	0.803		0.831
H	15.10		15.50	0.594		0.610
J	5.40		5.65	0.213		0.222
K	1.10		1.40	0.043		0.055
L	1.35		1.50	0.053		0.059
P	2.80		3.00	0.110		0.118
R		4.35			0.171	

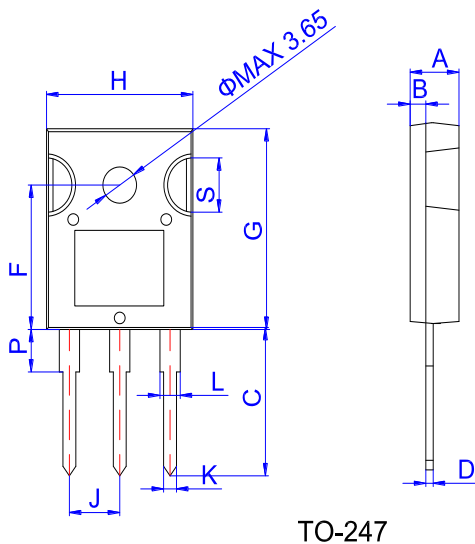

Ref.	Dimensions					
	Millimeters			Inches		
	Min.	Typ.	Max.	Min.	Typ.	Max.
A	4.9		5.4	0.193		0.213
B	1.6		2.0	0.063		0.079
C	14.35		15.4	0.565		0.606
D	0.5		0.8	0.020		0.031
F	14.4		15.1	0.567		0.594
G	19.7		20.6	0.775		0.811
H	15.4		16.2	0.606		0.638
J	5.3		5.6	0.209		0.220
K	1.3		1.5	0.051		0.059
L	2.8		3.3	0.110		0.130
P	3.7		4.2	0.146		0.165
S	5.35		5.65	0.211		0.222

PACKAGE MECHANICAL DATA

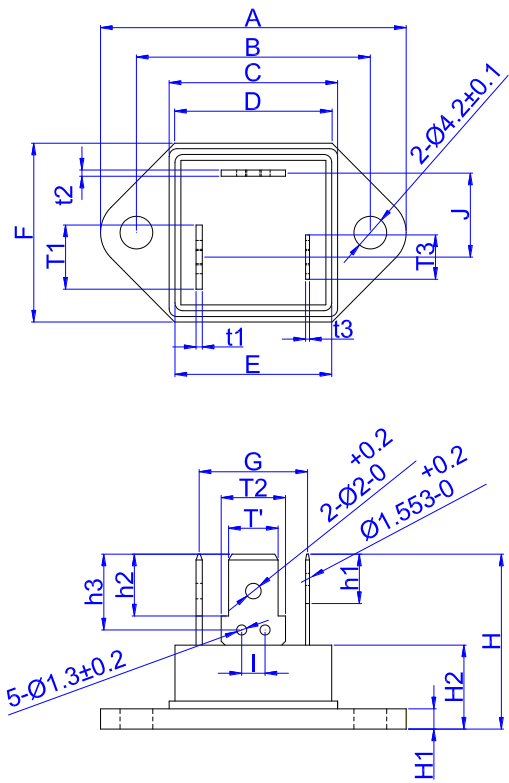

TG-C

Ref.	Dimensions					
	Millimeters			Inches		
	Min.	Typ.	Max.	Min.	Typ.	Max.
A			39.2			1.543
B	29.8	30.0	30.2	1.173	1.181	1.189
C			21.6			0.85
D			20.2			0.795
E			20.5			0.791
F			23			0.906
T1、T2		8.10			0.318	
T3		5.65			0.222	
T'		6.35			0.25	
t1、t2		0.8			0.031	
t3		0.6			0.023	
G		13.9			0.547	
H1		2.6			0.102	
H2		10.8			0.425	
H			22.8			0.886
h1	6.2	6.35	6.5	0.244	0.25	0.256
h2	7.8	7.95	8.1	0.307	0.313	0.319
h3	9.45	9.75	10.05	0.372	0.384	0.396
I	2.7	3.0	3.3	0.106	0.118	0.130
J		10.8			0.425	

MARKING

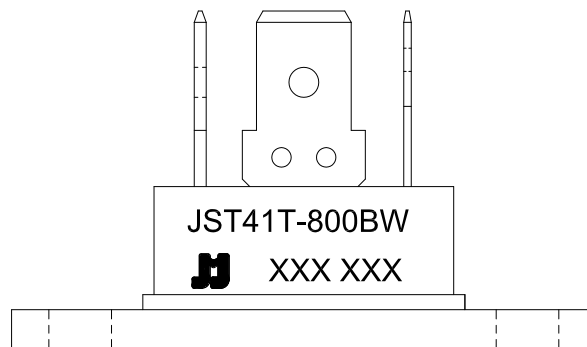

TG-C marking

**FIG.1** Maximum power dissipation versus RMS on-state current

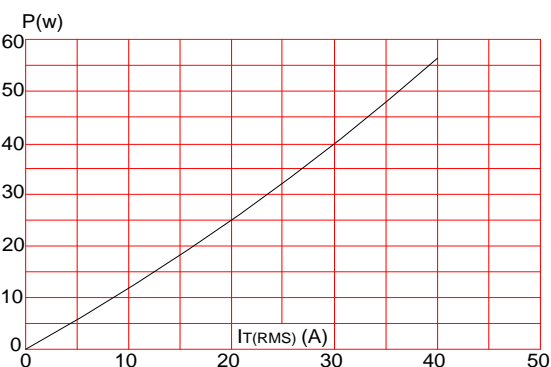

**FIG.3:** Surge peak on-state current versus number of cycles

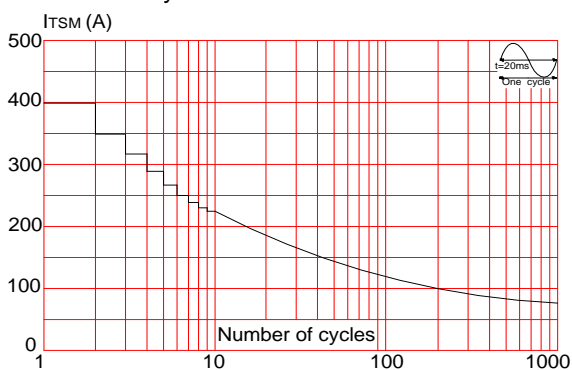

**FIG.5:** Non-repetitive surge peak on-state current for a sinusoidal pulse with width  $t_p < 20\text{ms}$ , and corresponding value of  $I^2t$  ( $di/dt < 50\text{A}/\mu\text{s}$ )

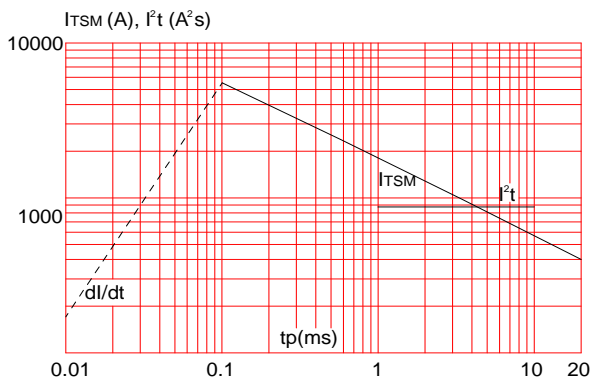

**FIG.2:** RMS on-state current versus case temperature

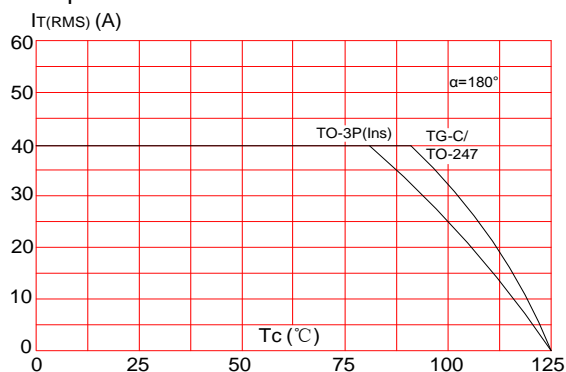

**FIG.4:** On-state characteristics (maximum values)

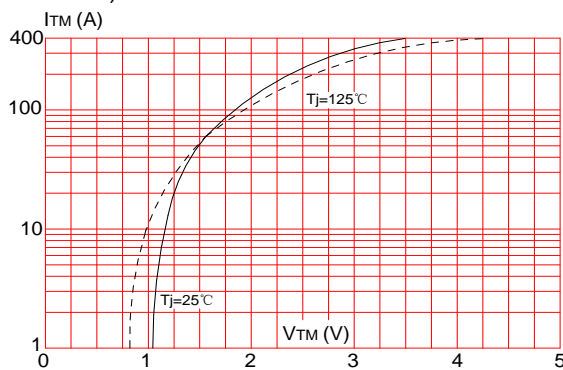

**FIG.6:** Relative variations of gate trigger current, holding current and latching current versus junction temperature

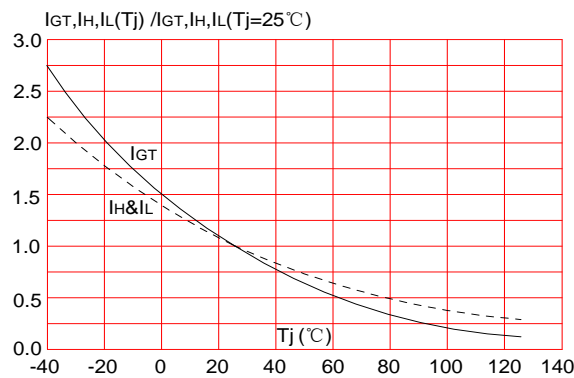

Information furnished in this document is believed to be accurate and reliable. However, Jiangsu JieJie Microelectronics Co.,Ltd assumes no responsibility for the consequences of use without consideration for such information nor use beyond it. Information mentioned in this document is subject to change without notice, apart from that when an agreement is signed, Jiangsu JieJie complies with the agreement. Products and information provided in this document have no infringement of patents. Jiangsu JieJie assumes no responsibility for any infringement of other rights of third parties which may result from the use of such products and information. This document is the fourth version which is made in 9-June-2015. This document supersedes and replaces all information previously supplied.

 is a registered trademark of Jiangsu JieJie Microelectronics Co.,Ltd.

Copyright ©2015 Jiangsu JieJie Microelectronics Co.,Ltd. Printed All rights reserved.

## X-ON Electronics

Largest Supplier of Electrical and Electronic Components

*Click to view similar products for [Triacs](#) category:*

*Click to view products by [JieJie](#) manufacturer:*

Other Similar products are found below :

[BT137-600-0Q](#) [OT415Q](#) [2N6075A](#) [NTE5688](#) [BTA2008W-800D,135](#) [D31410](#) [BT136-600,127](#) [BT137B-800,118](#) [BTA140-600,127](#)  
[BTA208-800B,127](#) [MAC97A6,116](#) [BTA420-800BT,127](#) [BTA201W-800E,115](#) [BTA26-800CWRG](#) [BTA41-800BRG](#) [TMA164P-L](#)  
[TMA166P-L](#) [TMA54S-L](#) [BT137-600E,127](#) [BTA140-800,127](#) [BTB16-600CW3G](#) [TMA84S-L](#) [Z0109MN,135](#) [T825T-6I](#) [T1635T-6I](#) [T1220T-](#)  
[6I](#) [NTE5638](#) [ACST1235-8FP](#) [BT134-600D,127](#) [BT134-600G,127](#) [BT136X-600E,127](#) [BT139X-800,127](#) [BTA204X-800C,127](#) [BTA216-](#)  
[600E,127](#) [BTA316X-600E/DG,12](#) [BTA316X-800C,127](#) [BT134-600D,127](#) [BT134-600E,127](#) [BT137X-600D,127](#) [BT139X-600E,127](#) [BTA08-](#)  
[600BW3G](#) [BTA201-800ER,126](#) [BTA208X-1000B,127](#) [BTA316X-800E,127](#) [NTE56008](#) [NTE56017](#) [NTE56018](#) [NTE56059](#) [NTE5608](#)  
[NTE5609](#)