

DESCRIPTION

LCXXCI a 3.3V-30V bi-directional TVS diode , utilizing leading monolithic silicon technology to provide fast response time and low ESD clamping voltage, making his device an ideal solution for protecting voltage sensitive high-speed data lines. The LCX XCI has a low capacitance with a typical value at 1pF, and com -plies with the IEC61000-4-2(ESD) standard with $\pm 30\text{kV}$ air and $\pm 30\text{kV}$ contact discharge. It is assembled into a lead free SOD-323 package. The small size, low capacitance and high ESD surge protection make LCXXCI an idea choice to protect cell phon -e, wireless systems, and communication equipment.

APPLICATIONS

- ✧ USB Ports.
- ✧ Smart Phones.
- ✧ Wireless Systems.
- ✧ Ethernet 10/100/1000 Base T.

FEATURES

- ✧ 350W peak pulse power (8/20 μs).
- ✧ Ultra low capacitance: 1.2pF typical.
- ✧ Ultra low leakage: nA leel.
- ✧ Low operating :3.3V ,5V,8V,12V,15V,18V,24V,30V.
- ✧ Low clamping voltage.
- ✧ Protects one power line or data line.
- ✧ Complies with following standards:
 - IEC 61000-4-2 (ESD) immunity test
 - Air discharge: $\pm 30\text{kV}$
 - Contact discharge: $\pm 30\text{kV}$.
- ✧ – IEC61000-4-4 (EFT) 40A (5/50ns).
- ✧ RoHS Compliant.
- ✧ Package: SOD-323.

ORDERING INFORMATION

Part NO	packaging	Reel Size
LC03CI	3000/Tape & Reel	7 inch
LC05CI	3000/Tape & Reel	7 inch
LC08CI	3000/Tape & Reel	7 inch
LC12CI	3000/Tape & Reel	7 inch
LC15CI	3000/Tape & Reel	7 inch
LC18CI	3000/Tape & Reel	7 inch
LC24CI	3000/Tape & Reel	7 inch
LC30CI	3000/Tape & Reel	7 inch

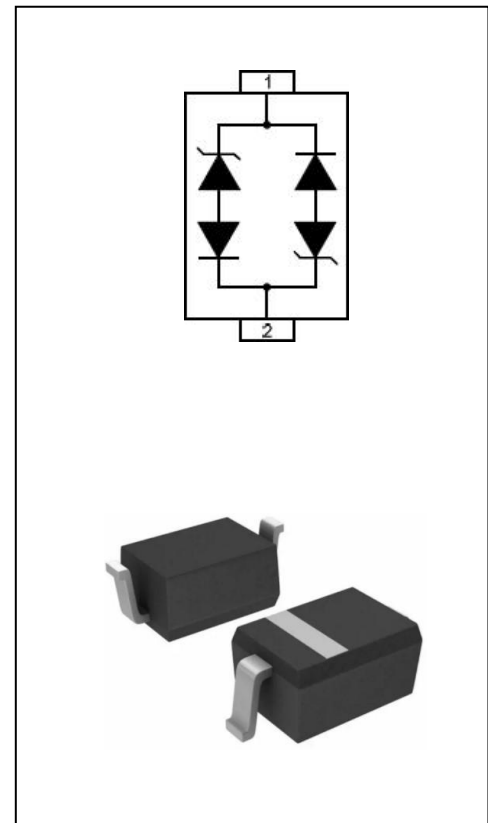

DEVICE CHARACTERISTICS
Absolute Maximum Ratings ($T_A=25^{\circ}\text{C}$ unless otherwise specified)

Parameter	Symbol	Value	Unit
Peak Pulse Power (8/20 μs)	P _{pp}	350	W
Peak Pulse Current (8/20 μs)	I _{pp}	22-6	A
ESD per IEC 61000-4-2 (Air)	V _{ESD}	± 30	kV
ESD per IEC 61000-4-2 (Contact)		± 30	
Operating Temperature Range	T _J	-40 to +85	$^{\circ}\text{C}$
Storage Temperature Range	T _{stg}	-55 to +150	$^{\circ}\text{C}$

ELECTRICAL CHARACTERISTICS($T_A=25^{\circ}\text{C}$ unless otherwise specified)

LC03CI						
Parameter	Symbol	Test Condition	Min	Typ	Max	Unit
Reverse Working Voltage	V _{RWM}				3.3	V
Breakdown Voltage	V _{BR}	I _T = 1mA	4		6	V
Reverse Leakage Current	I _R	V _{RWM} = 3.3 V			0.2	μA
Clamping Voltage	V _C	I _{PP} = 1A (8 x 20 μs pulse)			5	V
Clamping Voltage	V _C	I _{PP} = 22A (8 x 20 μs pulse)			16	V
Junction Capacitance	C _J	V _R = 0V, f = 1MHz		1.2		pF

LC05CI						
Parameter	Symbol	Test Condition	Min	Typ	Max	Unit
Reverse Working Voltage	V _{RWM}				5.0	V
Breakdown Voltage	V _{BR}	I _T = 1mA	6.2	6.8	8.0	V
Reverse Leakage Current	I _R	V _{RWM} = 5.0 V			0.5	μA
Clamping Voltage	V _C	I _{PP} = 1A (8 x 20 μs pulse)		8.5		V
Clamping Voltage	V _C	I _{PP} = 22A (8 x 20 μs pulse)		17.0	20	V
Junction Capacitance	C _J	V _R = 0V, f = 1MHz		1.0	1.5	pF

LC08CI						
Parameter	Symbol	Test Condition	Min	Typ	Max	Unit
Reverse Working Voltage	V_{RWM}				8.0	V
Breakdown Voltage	V_{BR}	$I_T = 1mA$	8.5			V
Reverse Leakage Current	I_R	$V_{RWM} = 8 V$			0.2	μA
Clamping Voltage	V_C	$I_{PP} = 1A (8 \times 20\mu s \text{ pulse})$			13	V
Clamping Voltage	V_C	$I_{PP} = 18A (8 \times 20\mu s \text{ pulse})$			19.5	V
Junction Capacitance	C_J	$V_R = 0V, f = 1MHz$		1		pF

LC12CI						
Parameter	Symbol	Test Condition	Min	Typ	Max	Unit
Reverse Working Voltage	V_{RWM}				12.0	V
Breakdown Voltage	V_{BR}	$I_T = 1mA$	13.3			V
Reverse Leakage Current	I_R	$V_{RWM} = 12 V$			0.2	μA
Clamping Voltage	V_C	$I_{PP} = 1A (8 \times 20\mu s \text{ pulse})$			18	V
Clamping Voltage	V_C	$I_{PP} = 12A (8 \times 20\mu s \text{ pulse})$			29	V
Junction Capacitance	C_J	$V_R = 0V, f = 1MHz$		1.2		pF

LC15CI						
Parameter	Symbol	Test Condition	Min	Typ	Max	Unit
Reverse Working Voltage	V_{RWM}				15.0	V
Breakdown Voltage	V_{BR}	$I_T = 1mA$	16.7			V
Reverse Leakage Current	I_R	$V_{RWM} = 15 V$			0.2	μA
Clamping Voltage	V_C	$I_{PP} = 1A (8 \times 20\mu s \text{ pulse})$			22	V
Clamping Voltage	V_C	$I_{PP} = 10A (8 \times 20\mu s \text{ pulse})$			32	V
Junction Capacitance	C_J	$V_R = 0V, f = 1MHz$		1.2		pF

LC18CI						
Parameter	Symbol	Test Condition	Min	Typ	Max	Unit
Reverse Working Voltage	V_{RWM}				18.0	V
Breakdown Voltage	V_{BR}	$I_T = 1\text{mA}$	20			V
Reverse Leakage Current	I_R	$V_{RWM} = 18\text{V}$			0.2	μA
Clamping Voltage	V_C	$I_{PP} = 1\text{A}$ (8 x 20 μs pulse)			26	V
Clamping Voltage	V_C	$I_{PP} = 10\text{A}$ (8 x 20 μs pulse)			35	V
Junction Capacitance	C_J	$V_R = 0\text{V}$, $f = 1\text{MHz}$		1		pF

LC24CI						
Parameter	Symbol	Test Condition	Min	Typ	Max	Unit
Reverse Working Voltage	V_{RWM}				24.0	V
Breakdown Voltage	V_{BR}	$I_T = 1\text{mA}$	26.7			V
Reverse Leakage Current	I_R	$V_{RWM} = 24\text{V}$			0.2	μA
Clamping Voltage	V_C	$I_{PP} = 1\text{A}$ (8 x 20 μs pulse)			43	V
Clamping Voltage	V_C	$I_{PP} = 8\text{A}$ (8 x 20 μs pulse)			55	V
Junction Capacitance	C_J	$V_R = 0\text{V}$, $f = 1\text{MHz}$		1.2		pF

LC30CI						
Parameter	Symbol	Test Condition	Min	Typ	Max	Unit
Reverse Working Voltage	V_{RWM}				30.0	V
Breakdown Voltage	V_{BR}	$I_T = 1\text{mA}$	33.3			V
Reverse Leakage Current	I_R	$V_{RWM} = 30\text{V}$			0.2	μA
Clamping Voltage	V_C	$I_{PP} = 1\text{A}$ (8 x 20 μs pulse)			50	V
Clamping Voltage	V_C	$I_{PP} = 10\text{A}$ (8 x 20 μs pulse)			75	V
Junction Capacitance	C_J	$V_R = 0\text{V}$, $f = 1\text{MHz}$		1.2		pF

TYPICAL CHARACTERISTICS($T_A=25^{\circ}\text{C}$ unless otherwise Specified)

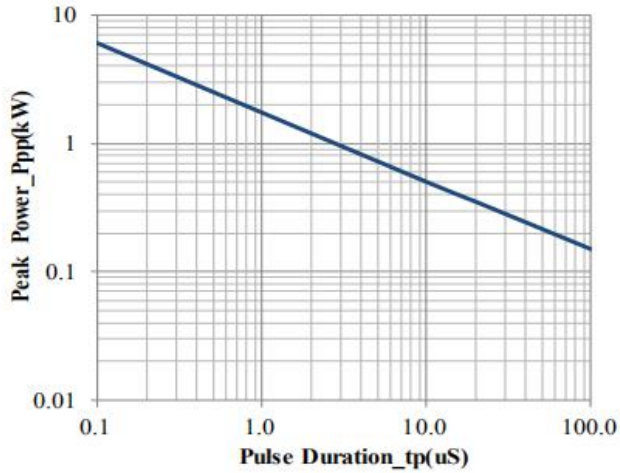

Peak Pulse Power vs. Pulse Time

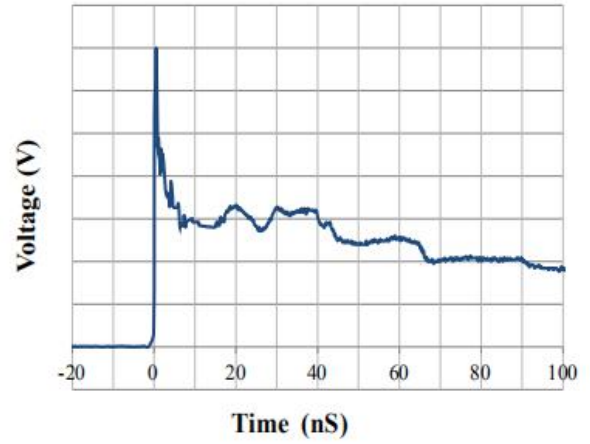

IEC61000-4-2 Pulse Waveform

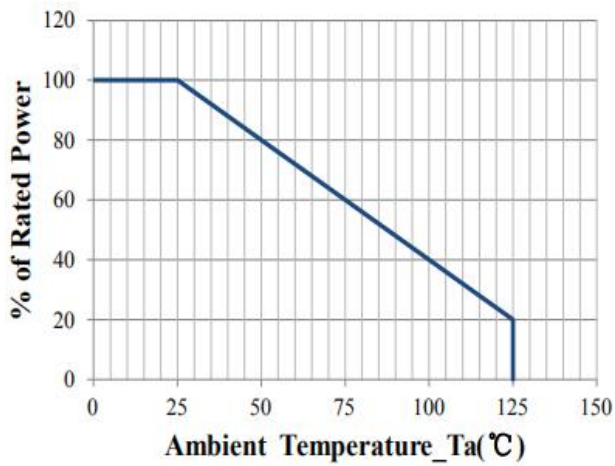

Power Derating Curve

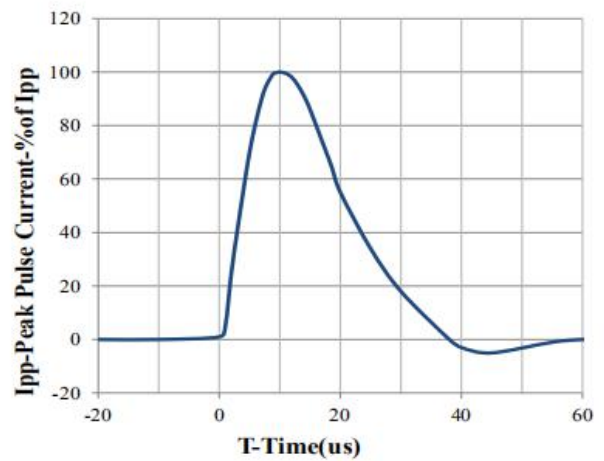

8 X 20us Pulse Waveform

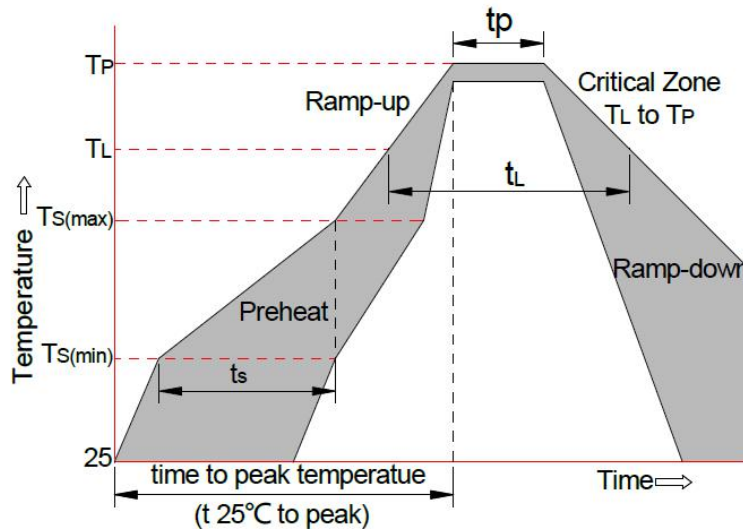
SOLDERING PARAMETERS

Reflow Condition		Pb-Free Assembly
Pre-heat	-Temperature Min (Ts (min))	+150°C
	-Temperature Max (Ts (max))	+200°C
	-Time (Min to Max) (ts)	60-180 secs
Average ramp up rate(Liquid us Temp (TL) to peak)		3°C/sec. Max
Ts (max) to TL-Ramp-up Rate		3°C/sec. Max
Reflow	-Temperature (TL) (Liquid us)	+217°C
	-Temperature (tL)	60-150 secs
Peak Temp (Tp)		+260(+0/-5)°C
Time within 5°C of actual Peak Temp (tp)		30 secs. Max
Ramp-down Rate		6 °C/secs. Max
xTime 25°C to Peak Temp (Tp)		8 min. Max
Do not exceed		+260°C

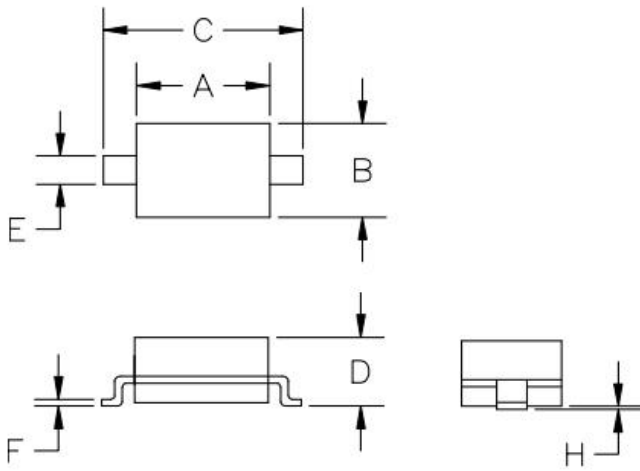
SOD-323 PACKAGE OUTLINE DRAWING

SYM	DIMENSIONS			
	MILLIMETERS		INCHES	
	MIN	MAX	MIN	MAX
A	1.50	1.80	0.060	0.071
B	1.20	1.40	0.045	0.054
C	2.30	2.70	0.090	0.107
D	-	1.10	-	0.043
E	0.30	0.40	0.012	0.016
F	0.10	0.25	0.004	0.010
H	-	0.10	-	0.004

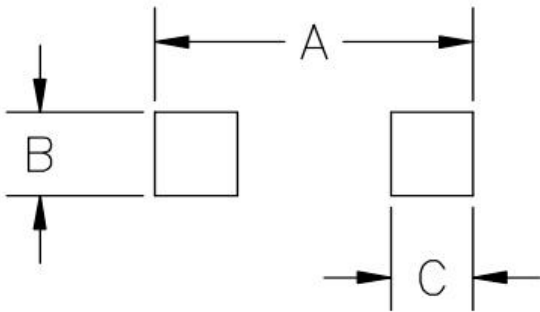
SUGGESTED LAND PATTERN

SYM	DIMENSIONS	
	MILLIMETERS	INCHES
A	3.15	0.120
B	0.80	0.031
C	0.80	0.031

Website: <http://www.jksemi.com>

For additional information, please contact your local Sales Representative.

©Copyright 2016, jksemi

X-ON Electronics

Largest Supplier of Electrical and Electronic Components

Click to view similar products for [ESD Suppressors / TVS Diodes](#) category:

Click to view products by [Jinkaisheng](#) manufacturer:

Other Similar products are found below :

[60KS200C](#) [D18V0L1B2LP-7B](#) [D5V0F4U5P5-7](#) [DESD5V0U1BB-7](#) [NTE4902](#) [P4KE27CA](#) [P6KE11CA](#) [P6KE39CA-TP](#) [P6KE8.2A](#)
[SA110CA](#) [SA60CA](#) [SA64CA](#) [SMBJ12CATR](#) [SMBJ33CATR](#) [SMBJ8.0A](#) [ESD101-B1-02ELS E6327](#) [ESD105-B1-02EL E6327](#) [ESD112-B1-02EL E6327](#) [ESD119B1W01005E6327XTSA1](#) [ESD5V0L1B02VH6327XTSA1](#) [ESD7451N2T5G](#) [19180-510](#) [CPDT-5V0USP-HF](#)
[3.0SMCJ33CA-F](#) [3.0SMCJ36A-F](#) [HSPC16701B02TP](#) [D3V3Q1B2DLP3-7](#) [D55V0M1B2WS-7](#) [DESD5V0U1BL-7B](#) [DRTR5V0U4SL-7](#)
[SCM1293A-04SO](#) [ESD200-B1-CSP0201 E6327](#) [SM12-7](#) [SMLJ45CA-TP](#) [CEN955 W/DATA](#) [82350120560](#) [VESD12A1A-HD1-GS08](#)
[CPDUR5V0R-HF](#) [CPDQC5V0U-HF](#) [CPDQC5V0USP-HF](#) [CPDQC5V0-HF](#) [D1213A-01LP4-7B](#) [D1213A-02WL-7](#) [MMAD1108/TR13](#)
[5KP100A](#) [5KP15A](#) [5KP18A](#) [5KP48A](#) [5KP90A](#) [5KP90CA](#)