

Surface Mountable PTC Resettable Fuse: JK-SMD0603 Series

Features:

- ✧ RoHS Compliant & Halogen Free
- ✧ faster tripping, 0603 Dimension, Surface mountable, Solid state
- ✧ Operation Current: 0.05A~0.35A
- ✧ Maximum Voltage: 6V~15Vdc
- ✧ Operating Temperature: -40°C TO 85°C



Product Dimensions

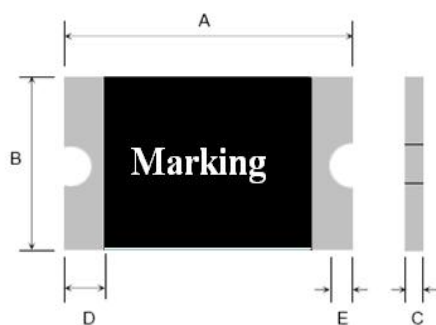

Unit : mm

Terminal pad materials :Tin-Plated Nickle-copper
Terminal pad solderability : Meets EIA specification
RS 186-9E and ANSI/J-STD-002 Category 3.

Model	Marking	A		B		C		D		E
		Min	Max	Min	Max	Min	Max	Min	Max	Max
JK-SMD0603-005	1	1.45	1.85	0.65	1.05	0.40	0.75	0.15	0.50	0.40
JK-SMD0603-010	1	1.45	1.85	0.65	1.05	0.40	0.75	0.15	0.50	0.40
JK-SMD0603-020	2	1.45	1.85	0.65	1.05	0.40	0.75	0.15	0.50	0.40
JK-SMD0603-025	3	1.45	1.85	0.65	1.05	0.40	1.00	0.15	0.50	0.40
JK-SMD0603-030	5	1.45	1.85	0.65	1.05	0.40	1.00	0.15	0.50	0.40
JK-SMD0603-035	5	1.45	1.85	0.65	1.05	0.40	1.00	0.15	0.50	0.40

Thermal Derating Chart-IH (A)

Model	Maximum ambient operating temperatures (°C)								
	-40	-20	0	25	40	50	60	70	85
JK-SMD0603-005	0.07	0.06	0.055	0.05	0.04	0.35	0.3	0.25	0.15
JK-SMD0603-010	0.14	0.12	0.11	0.1	0.8	0.7	0.6	0.5	0.3
JK-SMD0603-020	0.28	0.25	0.23	0.20	0.17	0.14	0.12	0.10	0.07
JK-SMD0603-025	0.35	0.31	0.29	0.25	0.21	0.18	0.15	0.13	0.09
JK-SMD0603-030	0.42	0.38	0.35	0.30	0.26	0.21	0.18	0.15	0.11
JK-SMD0603-035	0.47	0.44	0.39	0.35	0.30	0.27	0.24	0.20	0.14

ShenZhen JinRui Electronic Material Co.,Ltd

TEL: 0755-26546327 29356619

Web Site: <http://www.jkpptc.com>

Add: JinKe Industry Park ,No. 310,Wuhe Road ,Guanlan,Longhua,Shenzhen ,Guangdong .

Specifications are subject to change without notice !

FAX: 0755-26546562

E-mail: customer@jkpptc.com

Electrical Characteristic

Model	V_{max}	I_{max}	I_{hold}	I_{trip}	P_d	Maximum time to trip		Resistance	
	(Vdc)	(A)	(A)	(A)	Max. (W)	Current	Time	R_{min}	R_{max}
						(A)	(Sec)	(Ω)	(Ω)
JK-SMD0603-005	24.0	20	0.05	0.15	0.50	0.2	1.00	3.0	35.00
JK-SMD0603-010	15.0	40	0.10	0.30	0.50	0.5	1.00	0.9	8.00
JK-SMD0603-020	9.0	40	0.20	0.40	0.50	1.00	0.60	0.55	3.50
JK-SMD0603-025	9.0	40	0.25	0.55	0.50	8.0	0.08	0.500	3.00
JK-SMD0603-030	6.0	40	0.30	0.70	0.50	8A	0.10	0.300	2.00
JK-SMD0603-035	6.0	40	0.35	0.75	0.50	8A	0.10	0.200	1.40

Part Numbering System

JK- SMD0603 - □□□

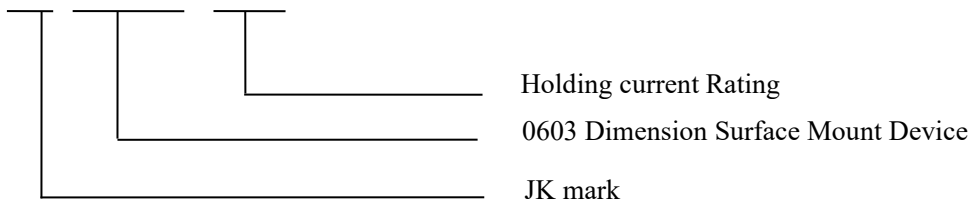
Test Procedures And Requirements

Test	Test Conditions	Accept/Reject Criteria
Resistance	In still air @ 25°C	$R_{min} \leq R \leq R_{max}$
Time to Trip	Specified current, V_{max} , 25°C	Tmaximum Time to Trip
Hold Current	30min, at I_H	No trip
Trip Cycle Life	V_{max} , I_{max} , 100cycles	No arcing or burning
Trip Endurance	V_{max} , 1 hours	No arcing or burning

Physical Characteristics and Environmental Specifications

Terminal materials :	Tin-Plated Nickle-copper
Soldering zone	Meets EIA specification RS 186-9E and ANSI/J-STD-002 Category 3.

Environmental Specifications

Test	Conditions	Resistance Change
Passive aging	85°C,1000hours	±10%
Humidity aging	85°C/85%RH.1000 hours	±5%

ShenZhen JinRui Electronic Material Co.,Ltd

TEL: 0755-26546327 29356619

 Web Site: <http://www.jkpptc.com>

Add: JinKe Industry Park ,No. 310,Wuhe Road ,Guanlan,Longhua,Shenzhen ,Guangdong。

Specifications are subject to change without notice !

FAX: 0755-26546562

E-mail:customer@jkpptc.com

Thermal shock	MIL-STD-202,Method 107G +85°C/-40°C,20times	-30% typical resistance change
Solvent Resistance	MIL-STD-202,Method 215	no change
Vibration	ML-STD-883C,Test Condition A	No chage

Electrical Specifications:

I_{hold} = Hold Current. Maximum current device will not trip in 25°C still air.

I_{trip} = Trip Current. Minimum current at which the device will always trip in 25°C still air.

V_{max} = Maximum operating voltage device can withstand without damage at rated current (I_{max}).

I_{max} = Maximum fault current device can withstand without damage at rated voltage (V_{max}).

P_d = Maximum power dissipation when device is in the tripped state in 25°C still air environment at rated voltage.

$R_{i_{min/max}}$ = Minimum/Maximum device resistance prior to tripping at 25°C.

$R_{I_{max}}$ = Maximum device resistance is measured one hour post reflow.

Recommended pad layout (mm)

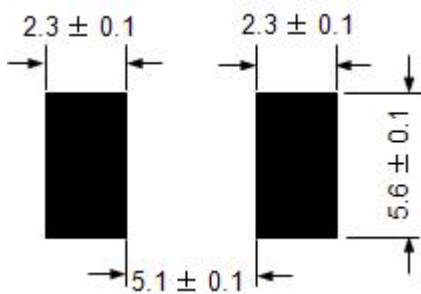

Solder reflow conditions

Profile Feature	Pb-Free Assembly
Average ramp up rate ($T_{S_{MAX}}$ to T_p)	3°C/second max.
Preheat	
• Temperature min. ($T_{S_{MIN}}$)	150°C
• Temperature max. ($T_{S_{MAX}}$)	200°C
• Time ($t_{S_{MIN}}$ to $t_{S_{MAX}}$)	60-120 seconds
Time maintained above:	
• Temperature (T_L)	217°C
• Time (t_L)	60-150 seconds
Peak/Classification temperature (T_p)	260°C
Time within 5°C of actual peak temperature	
Time (t_p)	30 seconds max.
Ramp down rate	3°C/second max.
Time 25°C to peak temperature	8 minutes max.

Note: All temperatures refer to topside of the package, measured on the package body surface.

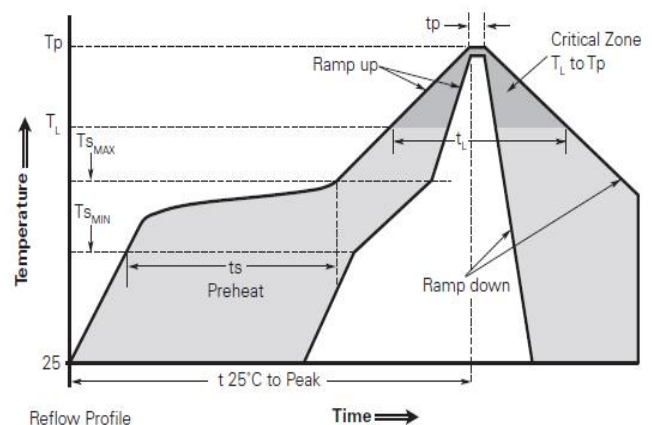

- Recommended reflow methods: IR, vapor phase oven, hot air oven, N2 environment for lead-free.
- Devices are not designed to be wave soldered to the bottom side of the board.
- Recommended maximum paste thickness is 0.25mm (0.010inch).
- Devices can be cleaned using standard industry methods and solvents.
- Soldering temprature profile meets RoHs leadfree process.

Notes: If reflow temperatures exceed the recommended profile, devices may not meet the performance requirements

Tape Specification And Reel Dimensions

Covering Specifications EIA 481-1(Unit:mm)	
W	8.00± 0.10
P ₀	4.0 ± 0.10
P ₁	4.0± 0.10
P ₂	2.0 ± 0.05
A ₀	0.95 ± 0.10
B ₀	1.85± 0.05
D ₀	1.55± 0.05
F	3.50± 0.05
E ₁	1.75 ± 0.10
T	0.20± 0.02
Leader min.	390
Trailer min.	160
Reel Dimensions	
A	178±1.0
N	59±1
W ₁	8.5+1.0/-0.2
W ₂	12.0±1

EIA Tape Component Dimentionis

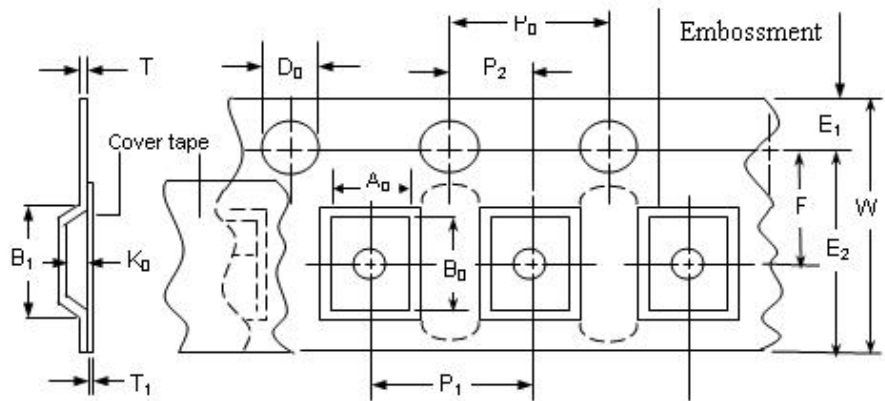

EIA Reel Dimentionis

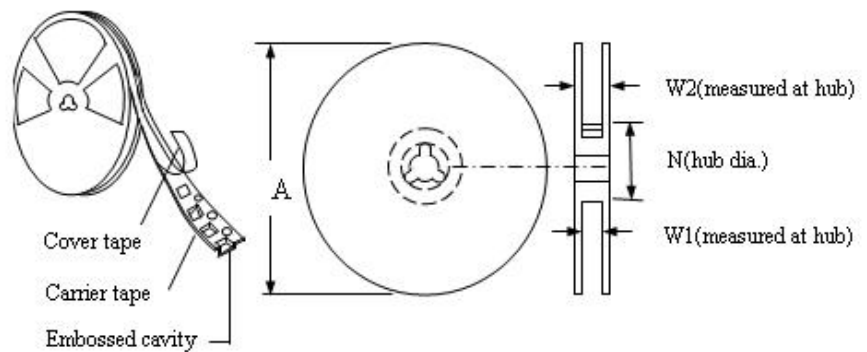

Packaging Quantity

Model	Quantity	Model	Quantity
JK-SMD0603-005	5000	JK-SMD0603-025	5000
JK-SMD0603-010	5000	JK-SMD0603-030	4000
JK-SMD0603-020	5000	JK-SMD0603-035	4000



Storage

The maximum ambient temperature shall not exceed 38°C. Storage temperatures higher than 38°C could result in the deformation of packaging materials. The maximum relative humidity recommended for storage is 60%. High humidity with high temperature can accelerate the oxidation of the solder plating on the termination and reduce the solderability of the components. Sealed plastic bags with desiccant shall be used to reduce the oxidation of the termination and shall only be opened prior to use. The products shall not be stored in areas where harmful gases containing sulfur or chlorine are present

WARNING

- Use PPTC beyond the maximum ratings or improper use may result in device damage and possible electrical arcing and flame.
- PPTC are intended for protection against occasional over current or over temperature fault conditions and should not be used when repeated fault conditions or prolonged trip events are anticipated.
- Device performance can be impacted negatively if devices are handled in a manner inconsistent with recommended electronic, thermal, and mechanical procedures for electronic components.
- Use PPTC with a large inductance in circuit will generate a circuit voltage ($L di/dt$) above the rated voltage of the PPTC.
- Avoid impact PPTC device its thermal expansion like placed under pressure or installed in limited space.
- Contamination of the PPTC material with certain silicon based oils or some aggressive solvents can adversely impact the performance of the devices.PPTC SMD can be cleaned by standard methods.
- Requests that customers comply with our recommended solder pad layouts and recommended reflow profile. Improper board layouts or reflow profile could negatively impact solderability performance of our devices.

Notes:

The specification is intended to present application,product and technical data to assist the user in selecting PPTC circuit production devices,However,users should imdependently evaluate and test the suitability of each product.JinRui makes on warranties as to the acduracy or completeness of the information and disclaims any liatality resulting form its use,JinRui's only obligations are those im the JinRui Standard Rerms and Conditions of Sale and in no case will JinRui be liable for any incidental,imdirect,or consequential damages arising from the sale,resale,or misues of its products. Jinrui reserves the right to change of update, without notice, any information contained in this specification.

X-ON Electronics

Largest Supplier of Electrical and Electronic Components

Click to view similar products for [Resettable Fuses - PPTC](#) category:

Click to view products by [Jinrui Electronic Materials](#) manufacturer:

Other Similar products are found below :

[RF0077-000](#) [RF0627-000](#) [RF3301-000](#) [RF3382-000](#) [RF3394-000](#) [RF3399-000](#) [SMD125-2](#) [RF1973-000](#) [RF2531-000](#) [RF2873-000](#) [RF3060-000](#) [RF3311-000](#) [TR600-150Q-B-0.5-0.130](#) [RXE090](#) [5E4795/04-1502](#) [TRF250-080T-B-1.0-0.125](#) [SMD100-2](#) [NIS5431MT1TXG](#) [SMD250-2](#) [RS30-090](#) [RS30-600](#) [RS30-800](#) [RS30-900](#) [RS60RB-160](#) [RS60SB-250](#) [SB250-145](#) [K30U400](#) [0ZCH0110AF2E](#) [BK60-110-DI-E0.6](#) [BK250-120-SZ-E0.6](#) [BK60-010-DI-E0.5](#) [BK250-040-DY-E0.6](#) [RF2631-000](#) [NIS4461MT3TXG](#) [NIS5420MT2TXG](#) [NIS5420MT3TXG](#) [NIS6420MT1TWG](#) [RF5032-000](#) [RF5051-000](#) [RF5105-000](#) [RF5062-000](#) [RF5055-000](#) [RF5052-000](#) [2920L075/72MR](#) [BSMD0603-025-24V](#) [BSMD0402L-005](#) [BSMD0603-010-9V](#) [BSMD1812-020-60V](#) [BSMD2920-400-30V](#) [BSMD0603-010-12V](#)