

## PPTC of JK-SMD 0603 (L) Series Surface-mount Devices

### Features:

- ✧ RoHS Compliant & Halogen Free
- ✧ Faster tripping, 0603 Dimension, Surface mountable, Solid state
- ✧ Operating Current: 0.35A~3.0A
- ✧ Maximum Voltage: 6V
- ✧ Operating Temperature: -40°C~ 85°C
- ✧ Certification: CSA

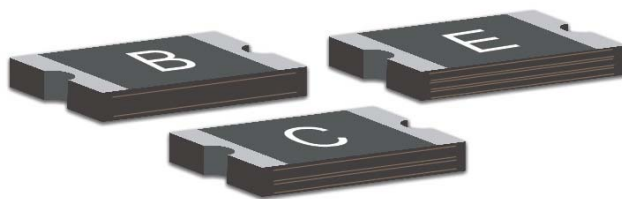

### Product Dimensions (mm)

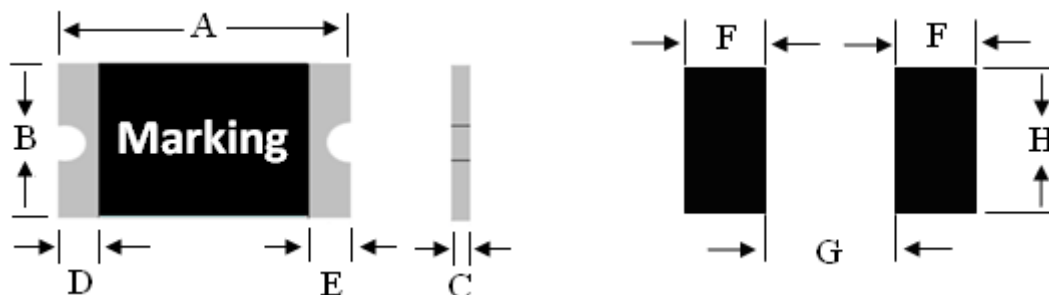

Part number	Marking	A		B		C		D	E
		Min	Max	Min	Max	Min	Max	Min	Min
JK-SMD-0603-035L	A	1.45	1.85	0.65	1.05	0.3	0.7	0.15	0.1
JK-SMD-0603-050L	A	1.45	1.85	0.65	1.05	0.3	0.7	0.15	0.1
JK-SMD-0603-075L	A	1.45	1.85	0.65	1.05	0.3	0.7	0.15	0.1
JK-SMD-0603-100L	B	1.45	1.85	0.65	1.05	0.4	1.0	0.15	0.1
JK-SMD-0603-125L	B	1.45	1.85	0.65	1.05	0.4	1.0	0.15	0.1
JK-SMD-0603-150L	C	1.45	1.85	0.65	1.05	0.5	1.2	0.15	0.1
JK-SMD-0603-175L	C	1.45	1.85	0.65	1.05	0.5	1.2	0.15	0.1
JK-SMD-0603-200L	C	1.45	1.85	0.65	1.05	0.7	1.4	0.15	0.1
JK-SMD-0603-260L	E	1.45	1.85	0.65	1.05	0.7	1.4	0.15	0.1
JK-SMD-0603-300L	E	1.45	1.85	0.65	1.05	0.7	1.4	0.15	0.1

**Recommended Solder Pad Layout Dimensions (mm)**

Device	F	G	H
	Normal Value	Normal Value	Normal Value
0603 Series	1.0	0.8	1.0

**Electrical Characteristics**

Model	V <sub>MAX</sub> (V)	I <sub>MAX</sub> (A)	I <sub>H</sub> (A)	I <sub>T</sub> (A)	P <sub>D</sub> (W)	Maximum Time-to-Trip		Resistance	
						Current	Time	R <sub>iMIN</sub>	R <sub>lMAX</sub>
						(A)	(Sec)	(Ω)	(Ω)
JK-SMD-0603-035L	6.0	50.0	0.35	0.70	0.5	8.0	0.1	0.15	1.0
JK-SMD-0603-050L	6.0	50.0	0.5	1.0	0.5	8.0	0.6	0.07	0.4
JK-SMD-0603-075L	6.0	50.0	0.75	1.5	0.5	8.0	1.0	0.055	0.25
JK-SMD-0603-100L	6.0	50.0	1.0	2.0	0.5	8.0	2.0	0.045	0.12
JK-SMD-0603-125L	6.0	50.0	1.25	2.5	0.5	8.0	3.0	0.035	0.10
JK-SMD-0603-150L	6.0	50.0	1.5	3.0	0.5	8.0	4.0	0.025	0.08
JK-SMD-0603-175L	6.0	50.0	1.75	3.5	0.5	8.0	5.0	0.015	0.07
JK-SMD-0603-200L	6.0	50.0	2.0	4.0	0.5	8.0	5.0	0.012	0.06
JK-SMD-0603-260L	6.0	50.0	2.6	5.2	0.5	8.0	5.0	0.008	0.05
JK-SMD-0603-300L	6.0	50.0	3.0	6.0	0.5	8.0	5.0	0.008	0.04

**Thermal Derating Chart-I<sub>H</sub>(A)**

Model	Maximum ambient operating temperature (°C)								
	-40	-20	0	25	40	50	60	70	85
JK-SMD-0603-035L	0.46	0.40	0.37	0.35	0.29	0.25	0.24	0.20	0.14
JK-SMD-0603-050L	0.66	0.57	0.53	0.50	0.41	0.36	0.34	0.28	0.21
JK-SMD-0603-075L	0.99	0.85	0.79	0.75	0.61	0.44	0.30	0.17	0.07
JK-SMD-0603-100L	1.32	1.14	1.05	1.00	0.82	0.73	0.69	0.56	0.41
JK-SMD-0603-125L	1.96	1.49	1.31	1.25	1.02	0.91	0.86	0.70	0.51
JK-SMD-0603-150L	2.35	1.79	1.58	1.50	1.22	1.09	1.03	0.84	0.62
JK-SMD-0603-175L	2.30	1.99	1.84	1.75	1.43	1.27	1.20	0.98	0.72
JK-SMD-0603-200L	2.63	2.27	2.10	2.00	1.63	1.45	1.37	1.12	0.82
JK-SMD-0603-260L	3.42	2.95	2.73	2.60	2.12	1.89	1.78	1.46	1.07
JK-SMD-0603-300L	3.95	3.41	3.15	3.00	2.45	2.18	2.06	1.68	1.23

**Test Procedures and Requirements**

Test Item	Test Conditions	Accept/Reject Criteria
Initial Resistance	In still air at 25°C	$R_{i_{min}} \leq R \leq R_{i_{max}}$
Time to Trip	Specified current, $V_{max}$ , 25°C	$T \leq$ Maximum Time to Trip
Holding Current	30min, at $I_H$ , 25°C	No trip
Trip Cycle Life	$V_{max}$ , $I_{max}$ , 100 cycles	No arcing or burning
Trip Endurance	$V_{max}$ , 1 hour	No arcing or burning

**Physical Characteristics**

Terminal Materials	Tin-Plated Nickle-copper
Soldering Zone	Meets EIA specification RS 186-9E and ANSI/J-STD-002 Category 3.
Moisture Sensitivity	Level 2a, per IPC/JEDEC J-STD 020C

**Environmental Specifications**

Test Item	Test Conditions	Resistance Change
Passive Aging	85°C, 1000 hours	±10% typical
Humidity Aging	85°C/85%RH, 100 hours	±5% typical
Thermal Shock	MIL-STD-202, Method 107G +85°C/-40°C, 20 times	-30% typical
Solvent Resistance	MIL-STD-202, Method 215	No change
Vibration	ML-STD-883C, Test Condition A	No change

**Electrical Specifications**

$I_H$ =Hold current: Maximum current at which the device will not interrupt in 25°C still air.

$I_T$ =Trip current: Minimum current at which the device from low resistance to high resistance in 25°C still air.

$V_{MAX}$ =Maximum continuous voltage device can withstand without damage at rated current.

$I_{MAX}$ =Maximum fault current device can withstand without damage at rated voltage.

Maximum Time-to-trip: Maximum time to trip at assigned current.

$P_D$ =Typical power dissipation: Typical amount of power dissipated from the device when in 25°C still air environment.

$R_{i_{MIN}}$ =Minimum resistance of device at 25°C prior to tripping.

$R_{i_{MAX}}$  = Maximum device resistance is measured one hour post reflow.

Solder Reflow Profiles

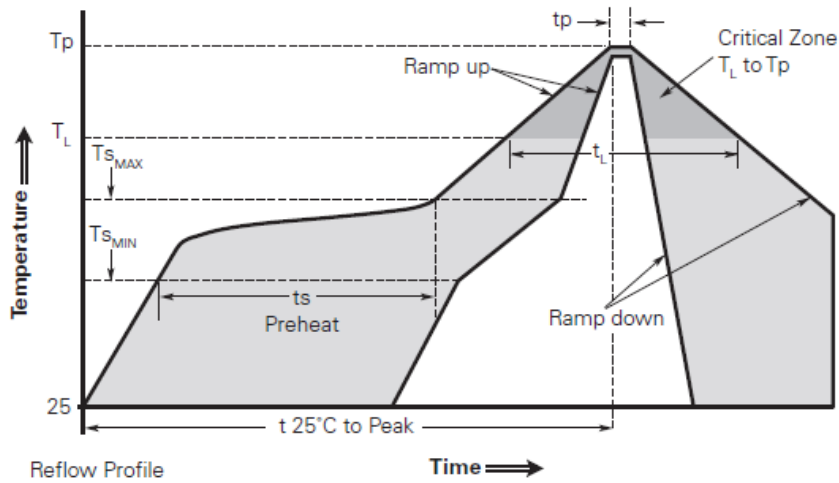

Profile Feature	Pb-Free Assembly
<b>Average ramp up rate(TsMAX to Tp)</b>	3°C/second max.
<b>Preheat</b>	
• Temperature min.(TsMIN)	150°C
• Temperature max.( TsMAX)	200°C
• Time (TsMIN to TsMAX)	60-120 seconds
<b>Time maintained above:</b>	
• Temperature (Tl)	217°C
• Time (Tl)	60-150 seconds
<b>Peak/Classification temperature (Tp)</b>	260°C
<b>Time within 5°C of actual peak temperature</b>	
Time (Tp)	30 seconds max.
<b>Ramp down rate</b>	3°C/second max.
<b>Time 25°C to peak temperature</b>	8 minutes max.

- Recommended reflow methods: IR, vapor phase oven, hot air oven, N2 environment for lead-free.
- Devices are not designed to be wave soldered to the bottom side of the board.
- Recommended maximum paste thickness is 0.25mm (0.010inch).
- Devices can be cleaned using standard industry methods and solvents.

Note 1: All temperature refer to topside of the package, measured on the package body surface.

Note 2: If reflow temperature exceed the recommended profile, devices may not meet the performance requirements.

Part Numbering System

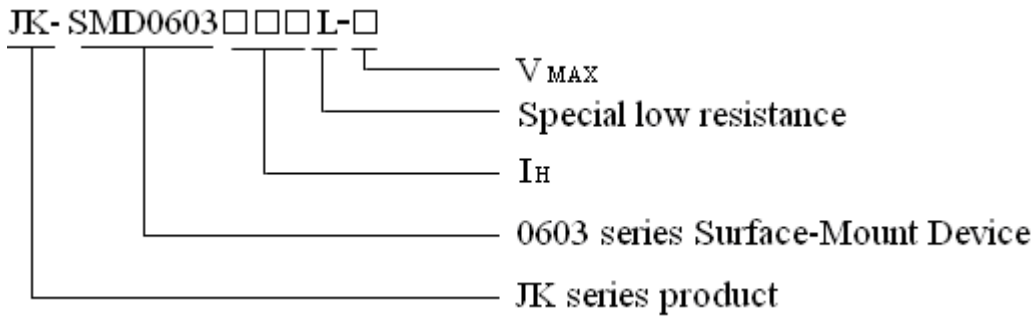

Tape Specifications and Reel Dimensions

Covering Specifications EIA 481-1	
W	8.0± 0.1
P <sub>0</sub>	4.0 ± 0.1
P <sub>1</sub>	4.0± 0.10
P <sub>2</sub>	2.0 ± 0.05
A <sub>0</sub>	0.95± 0.10
B <sub>0</sub>	1.85± 0.05
D <sub>0</sub>	1.55± 0.05
F	3.5 ± 0.05
E <sub>1</sub>	1.75 ± 0.10
T	0.20± 0.02
Leader min.	390
Trailer min.	160
Reel Dimensions	
A	178 ± 1
N	59 ± 1
W <sub>1</sub>	8.5+1.0/-0.2
W <sub>2</sub>	12.0±1

EIA Tape Component Dimensions

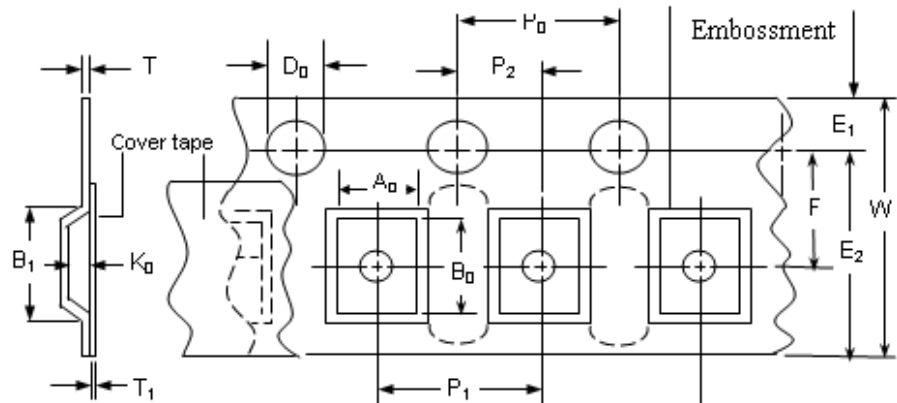

EIA Reel Dimensions

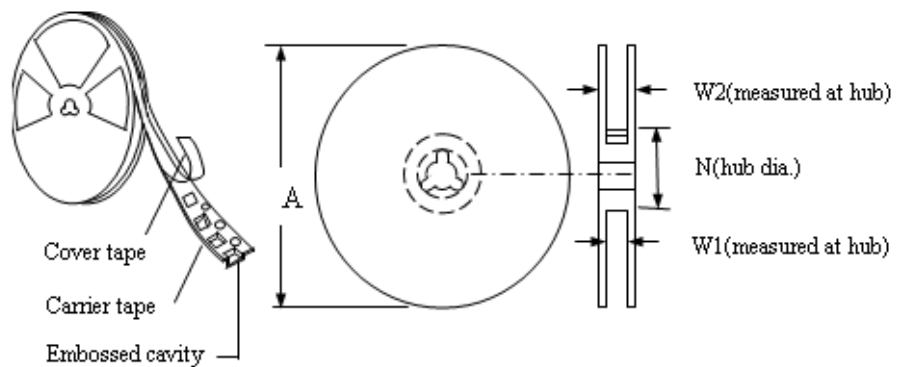

**Packaging Quantity**

Model	Quantity	Model	Quantity
JK-SMD-0603-035L	5000	JK-SMD-0603-150L	4000
JK-SMD-0603-050L	5000	JK-SMD-0603-175L	4000
JK-SMD-0603-075L	5000	JK-SMD-0603-200L	4000
JK-SMD-0603-100L	4000	JK-SMD-0603-260L	4000
JK-SMD-0603-125L	4000	JK-SMD-0603-300L	4000

**Storage**

The maximum ambient temperature shall not exceed 40°C. Storage temperatures higher than 40°C could result in the deformation of packaging materials. The maximum relative humidity recommended for storage is 70%. High humidity with high temperature can accelerate the oxidation the oxidation of the solder plating on the termination and reduce the solderability of the components. Sealed plastic bags with desiccant shall be used to reduce the oxidation of the termination and shall only be opened prior to use, the products shall not be stored in areas where harmful gases containing sulfur or chlorine are present.

**Warning**

- Please read this specification before using the product.
- Use PPTC beyond the maximum ratings or improper use may result in device damage, electrical arcing and flame.
- PPTC are intended for protection against occasional over current or over temperature fault conditions and should not be used when repeated fault conditions or prolonged trip events are anticipated.
- Device performance can be impacted negatively if devices are handled in a manner inconsistent with recommended electronic, thermal, and mechanical procedures for electronic components.
- Use PPTC with a large inductance in circuit will generate a circuit voltage above the rated voltage of the PPTC.
- Avoid impact PPTC device its thermal expansion like placed under pressure or installed in limited space.
- Contamination of the PPTC material with certain silicon based oils or some aggressive solvents can adversely impact the performance of the devices. PPTC can be cleaned by standard methods.
- Requests that customers comply with our recommended solder pad layouts and recommended reflow profile. Improper board layouts or reflow profile could negatively impact solderability performance of our devices.

**Notes**

The specification is intended to present application product and technical data to assist the user in selecting PPTC circuit production devices, However, users should independently evaluate and test the suitability of each product. Jinrui makes no warranties as to the accuracy or completeness of the information and disclaims any liability resulting from its use, Jinrui's only obligations are those in the Jinrui Standard Terms and Conditions of Sale and in no case will Jinrui be liable for any incidental, indirect, or consequential damages arising from the sale, resale, or misuse of its products. Jinrui reserves the right to change or update any information contained in this specification without notice.

## X-ON Electronics

Largest Supplier of Electrical and Electronic Components

*Click to view similar products for [Resettable Fuses - PPTC category](#):*

*Click to view products by [Jinrui Electronic Materials manufacturer](#):*

Other Similar products are found below :

[RF0077-000](#) [RF0627-000](#) [RF3301-000](#) [RF3382-000](#) [SMD125-2](#) [RF1973-000](#) [RF2531-000](#) [RF2873-000](#) [RF3060-000](#) [TR600-150Q-B-0.5-0.130](#) [RXE090](#) [5E4795/04-1502](#) [TRF250-080T-B-1.0-0.125](#) [SMD100-2](#) [NIS5431MT1TXG](#) [SMD250-2](#) [RS30-090](#) [RS30-600](#) [RS30-800](#) [RS30-900](#) [RS60RB-160](#) [RS60SB-250](#) [SB250-145](#) [OZCH0110AF2E](#) [0603L001/60YR](#) [0603L003/36YR](#) [BK250-120-SZ-E0.6](#) [BK60-010-DI-E0.5](#) [BK250-040-DY-E0.6](#) [RF2631-000](#) [NIS5420MT2TXG](#) [NIS5420MT3TXG](#) [NIS6420MT1TWG](#) [RF5032-000](#) [RF5051-000](#) [RF5034-000](#) [RF5105-000](#) [RF5062-000](#) [RF5055-000](#) [RF5052-000](#) [2920L075/72MR](#) [BSMD0603-025-24V](#) [BSMD0402L-005](#) [BSMD0603-010-9V](#) [BSMD1812-020-60V](#) [BSMD2920-400-30V](#) [BSMD0603-010-12V](#) [BSMD0805-035-30V](#) [BSMD1210-150-16V](#) [BSMD0805-003-60V](#)