

P/N LEGEND

A1007 WR-S-XP			
①	②	③	④
① Series No.	② Connector type: WR=Right angle	③ Mounting type: S=SMT without boss	④ No. of circuits

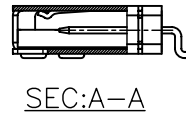
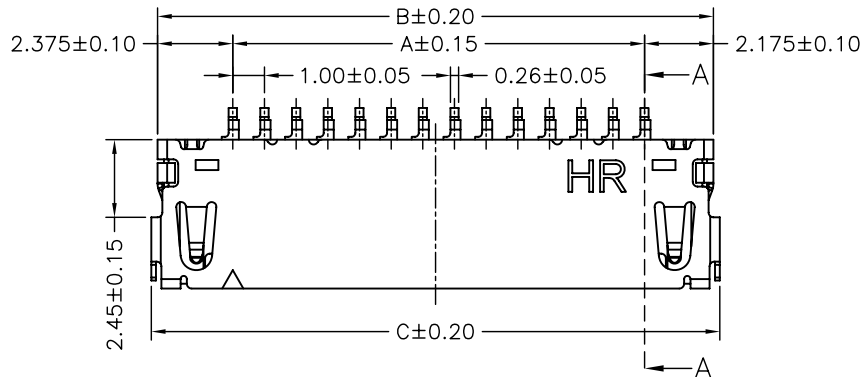

SPECIFICATIONS

Current Rating: 1A AC,DC
 Voltage Rating: 100V AC,DC
 Temperature Range: -25°C ~ +85°C
 Contact Resistance: 30mΩ Max.
 Insulation Resistance: 500MΩ Min.
 Withstanding Voltage: 500V AC/minute
 Shell: Phosphor Bronze/Tin-plated
 Pin: Phosphor Bronze/Contacts/Gold-plated
 3u" and Solder tabs/Gold-flash
 Material: LCP,UL94V-0
 Color: Natural(Beige)

PART NO.	Dimensions		
	A	B	C
A1007WR-S-08P	7.00	11.55	11.95
A1007WR-S-14P	13.00	17.55	17.95
A1007WR-S-20P	19.00	23.55	23.95
A1007WR-S-30P	29.00	33.55	33.95

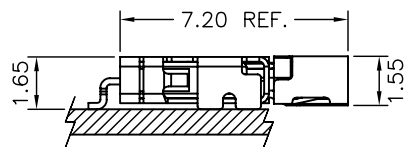
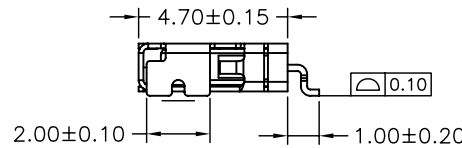
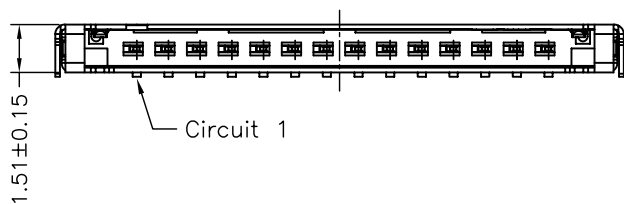

燦達電子工業股份有限公司 JOINT TECH ELECTRONIC IND. CO., LTD.				UNIT	SCALE	SHEET	TITLE:
				mm	1 : 1	1 of 2	
				DRAWN BY	APPROVED BY		1.00mm PITCH 90° WAFER-SMT TYPE
				董正一	董正一		
				2003.04.22	2003.04.22		
				GENERAL TOLERANCE			
B5	EN1705150001	2017.05.15	周傑亮	X. X±0.25	ANGLE±		DRAW NO. :
B4	EN1504150001	2015.04.15	黃模有	X. XX±0.15			
B3	EN1209030291	2012.11.13	陳錦展	X. XXX±0.05			
B2	EN1203230081	2012.05.04	程夢燕				REV. B5
REV.	DESCRIPTION	DATE	NAME				A1007WR-S-XP



08 contacts

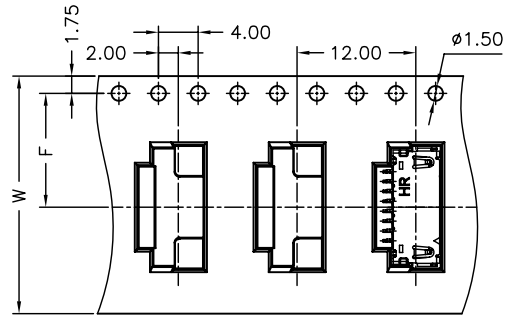

Unreeling direction →

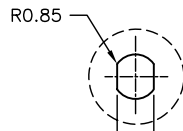
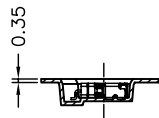

$1.50^{+0.10}_0$

14~30 contacts

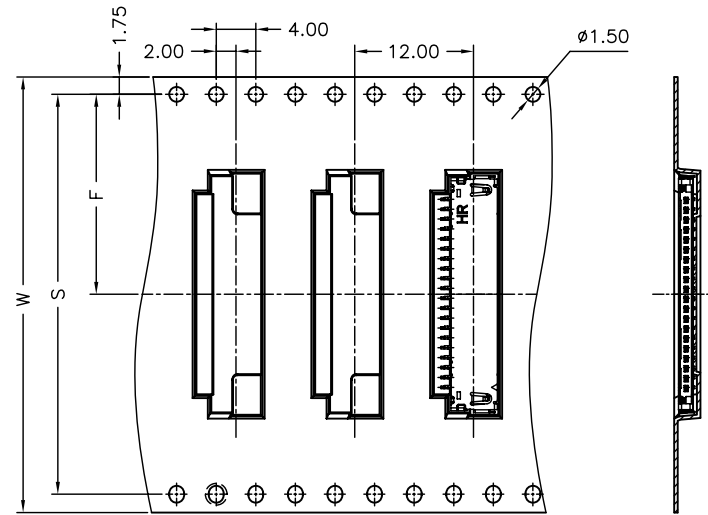

Unreeling direction →

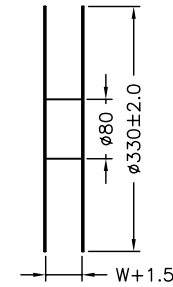
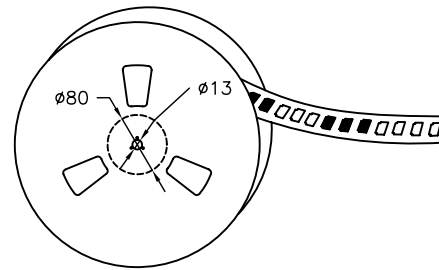
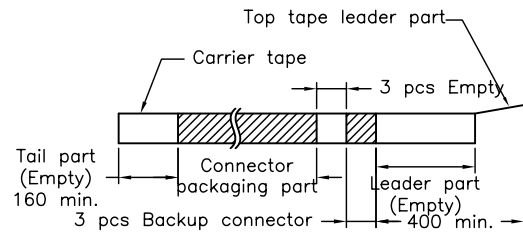

Number of Contacts	W±0.3	F±0.1	S±0.1	Q'ty/Reel
08P	24	11.50	28.40	2,000
14P	32	14.20	40.40	2,000
20P	44	20.20	52.40	2,000
30P	56	26.20		2,000

				燦達電子工業股份有限公司 JOINT TECH ELECTRONIC IND. CO., LTD.	
UNIT		SCALE	SHEET		TITLE:
mm		1 : 1	2 of 2		1.00mm PITCH 90° WAFER-SMT TYPE TAPING SPEC.
DRAWN BY		APPROVED BY		DRAW NO. : A1007WR-S-XP	
歐陽小強		謝瑞清			
2008.09.17		2008.09.17			
				GENERAL TOLERANCE	
B5	EN1705150001	2017.05.15	周傑亮	X. X±0.25	ANGLE±
B4	EN1504150001	2015.04.15	黃模有	X. XX±0.15	
B3	EN1209030291	2012.11.14	陳錦展	X. XXX±0.05	
B2	EN1203230081	2012.05.04	楊峰		
REV.	DESCRIPTION	DATE	NAME		

X-ON Electronics

Largest Supplier of Electrical and Electronic Components

Click to view similar products for [Headers & Wire Housings](#) category:

Click to view products by [Joint Tech](#) manufacturer:

Other Similar products are found below :

[57102-F02-18ULF](#) [58102-G61-06LF](#) [0009485154](#) [009176003701906](#) [0050291907](#) [02.125.8002.8](#) [609-3404](#) [61062-3](#) [622-0430](#) [622-3653LF](#)
[63453-116](#) [636-1030](#) [636-1427](#) [636-3427](#) [636-4007](#) [641938-9](#) [644827-2](#) [65495-038](#) [65692-001LF](#) [65781-018](#) [65781-047](#) [65817-010LF](#)
[65817-015LF](#) [66207-023LF](#) [67016-026LF](#) [67095-007LF](#) [68631-112](#) [68645-018](#) [68648-049](#) [699319-000](#) [70.362.1628.0](#) [70-4210](#) [70-4226B](#)
[70-4853B](#) [707-5020](#) [707-5028](#) [71.350.2428.0](#) [71961-016LF](#) [733-134](#) [754199-000](#) [760-3052](#) [787-8014-00](#) [FCN-367T-T012/H](#) [80.063.4001.1](#)
[800-90-001-10-001000](#) [800-90-010-10-002000](#) [801-43-002-10-013000](#) [801-43-006-10-002000](#) [803-41-018-10-001000](#) [803-43-014-20-](#)
[001000](#)