

Preliminary Specifications Subject to Change without Notice

DESCRIPTION

JW15158AS is an isolated offline Flyback converter with GaN integrated, which features quasi-resonant (QR) operation. QR control improves efficiency by reducing switching loss and benefits EMI performance with nature frequency variation, and an internal maximum frequency limitation to overcome the inherent disadvantages of QR Flyback.

JW15158AS combines PWM and PFM control at different input and load condition for highest average efficiency. It can comply with the most stringent efficiency regulations.

JW15158AS comprises a HV pin for startup to eliminate conventional startup resistor and save standby mode energy consumption. JW15158AS is available in HSOP-7 package. The high level of integration results in a simple to use, low component count, and high efficiency application solution for isolated power delivery.

Co Company's Logo is Protected, "JW" and "JOULWATT" are Registered

Trademarks of Joulwatt Technology Co., Ltd.

FEATURES

- Integrated 650V 2200mΩ GaN
- Built-in High-Voltage Startup (700V)
- Wider VDD Operation Range (Up to 90V)
- QR Operation for High Efficiency
- Maximum 110kHz Switching Frequency
- Optional OCP and OPP Function for Different PD and QC Output Application
- Very Low Standby Power Consumption
- Cycle-by-Cycle Current Limit
- Reliable Fault Protections: VDD OVP, VS OVP and UVP, Brown-In, CS Open Protection, OCP, OPP, Internal OTP
- Frequency Jitter to Ease EMI Compliance
- Available in HSOP-7 Package

APPLICATIONS

- PD and Quick-Charging Chargers
- AC/DC Adapters with Wide Output Range

TYPICAL APPLICATION

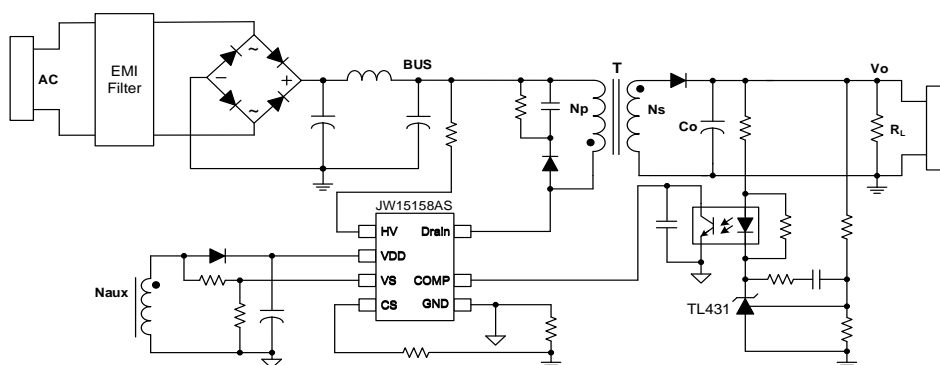

ORDER INFORMATION

DEVICE ¹⁾	PACKAGE	TOP MARKING ²⁾	ENVIRONMENTAL ³⁾
JW15158ASHSOPC#TR	HSOP-7	JW15158AS YW□□□□□	Green

Notes:

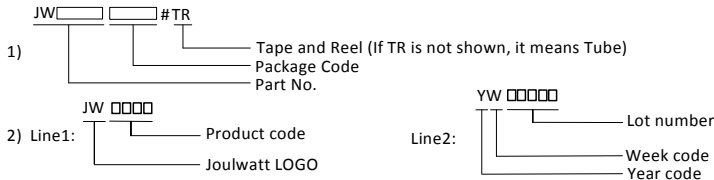

3) All Joulwatt products are packaged with Pb-free and Halogen-free materials and compliant to RoHS standards.

PIN CONFIGURATION

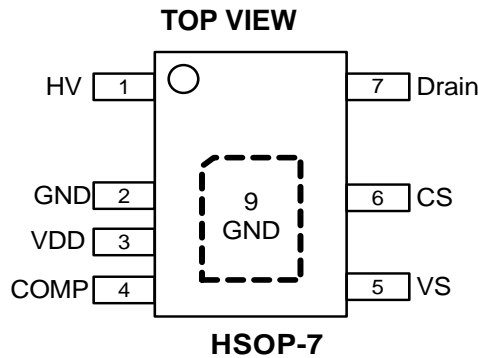

ABSOLUTE MAXIMUM RATING¹⁾

Drain Pin	700V
HV Pin	600V
VDD Pin	95V
COMP, CS Pin	-0.3V to 5V (5V to 5.5V<10us)
VS Pin	-0.3V to 5V (-0.7V to -0.3<10us, 5V to 5.5V<10us)
Junction Temperature ^{2) 3)}	150°C
Storage Temperature	-65°C to 150°C
Lead Temperature (Soldering, 10sec.)	260°C
Continuous Power Dissipation (TA = +25 °C) ⁴⁾ HSOP-7.....	2.5W

RECOMMENDED OPERATING CONDITIONS

VDD Voltage	8V to 83V
Operating Junction Temperature (T _J)	-40°C to 125°C

THERMAL PERFORMANCE⁵⁾ θ_{JA} θ_{Jc}

HSOP-7.....50...3°C/W

Note:

- 1) Exceeding these ratings may damage the device. These stress rating do not imply function operation of the device at any other conditions beyond those indicated under RECOMMENDED OPERATING CONDITIONS.
- 2) JW15158AS includes thermal protection that is intended to protect the device in overload conditions. Continuous operation over the specified absolute maximum operating junction temperature may damage the device.
- 3) The device is not guaranteed to function outside of its operating conditions.
- 4) The maximum allowable continuous power dissipation at any ambient temperature is calculated by $PD (MAX) = (TJ (MAX) - TA) / \theta_{JA}$.
- 5) Measured on JESD51-7, 4-layer PCB.

ELECTRICAL CHARACTERISTICS

<i>T_A = 25°C, unless otherwise stated.</i> <i>Advance Information, not production data, subject to change without notice.</i>						
Item	Symbol	Condition	Min.	Typ.	Max.	Units
High Voltage Section (HV Pin)						
Supply Current from HV Pin	I _{HV}	V _{HV} =120V, V _{DD} =0V		3		mA
Leakage Current of HV Pin	I _{HV_LK}	V _{HV} =500V, V _{DD} =20V		20		uA
Brown-in Threshold	V _{BR_IN}		107	112	117	V
Brown-out Threshold	V _{BR_OUT}		93	98	102	V
Brown-out Blanking Time ⁷⁾	t _{BR_OUT}			70		ms
Supply Voltage Section (VDD Pin)						
Turn-on Threshold Voltage	V _{DD_ON}	VDD Rising	14.8	16.5	18.1	V
Turn-off Threshold Voltage	V _{DD_OFF}	VDD Falling	7	7.5	8	V
Reset Threshold Voltage	V _{DD_RST}		4	4.5	5	V
Startup Current	I _{DD_ST}	V _{DD} =V _{DD_ON} -0.5 V,		300		uA
Operating Supply Current	I _{DD_OP}	V _{DD} =20V, f _s =110kHz		0.9		mA
VDD OVP Voltage	V _{DD_OVP}		88	90	94.5	V
Voltage Sense Section (VS Pin)						
Maximum VS Source Current Capability	I _{VS_MAX}		3	3.5	4	mA
Output OVP Threshold	V _{VS_OVP}		2.9	3	3.1	V
Output UVP Threshold	V _{VS_UVP}			0.5		V
Adaptive Blanking Time for VS Sampling	t _{VS_BLK}	COMP=0.5V		0.6		us
		COMP=3.6V		2		us
Output OVP Debounce Cycle Counts ⁶⁾	N _{VS_OVP}			3		Cycle
Output UVP Blanking Time ⁷⁾	t _{VS_UVP}			120		ms
Auto-restart Cycles for UVP ⁷⁾	N _{UVP_HIC}			4		Cycle
Current Sense Section (CS Pin)						
Max CS Offset Current	I _{CS_MAX}	V _{DD} =20V, COMP=3.6V	96	100	104	uA
Min CS Offset Current	I _{CS_MIN}	V _{DD} =20V, COMP=0.5V at Burst Mode	23	25	27	uA
CS Off Threshold	V _{CS_TH}			0		mV
Leading Edge Blanking Time ⁷⁾	t _{LEB}			150	200	ns
Frequency Section						
Maximum Switching Frequency	f _{max}			110		kHz
Minimum Switching Frequency	f _{min}		21	25	29	kHz
Maximum-on Time	T _{ON_MAX}		15	18		us

Minimum-on Time	T _{ON_MIN}			180	220	ns
Maximum-off Time	T _{OFF_MAX}		70	80	90	us
Frequency Jittering Amplitude to COMP ⁷⁾	ΔF _{JIT}			±7%		
Counting Cycles for Jittering ⁷⁾	N _{JIT_CYC}			32		Cycle
Feedback Section (COMP Pin)						
Open Pin Voltage ⁷⁾	V _{COMP_MAX}	Open Loop		3.9	4.0	4.1
Internal Pull-up Resistor ⁶⁾	R _{COMP_UP}			20		kΩ
COMP to CS Offset Current Gain	G _{COMP_CS}	COMP > 2.8V		20		V/mA
		COMP < 1.0V		16		V/mA
Threshold Enter PFM Mode	V _{COMP_PFM}			2.8		V
Threshold Enter Burst Mode	V _{BUR_L}		0.48	0.5	0.52	V
Threshold Exit Burst Mode	V _{BUR_H}		0.57	0.6	0.63	V
GaN Section						
Drain-source On-state Resistance	R _{DS_ON}			1600	2200	mΩ
Internal Over Temperature Protection						
Thermal Shutdown Threshold ⁷⁾	T _{OTP}			140		°C
OTP Hysteresis ⁷⁾	T _{HYS}			30		°C

Note:

- 6) Guaranteed by design.
- 7) Derived from bench characterization. Not tested in production.

PIN DESCRIPTION

Pin HSOP-7	Name	Description
1	HV	High voltage input pin. This pin provides a source current to charge VDD. This pin also sense input voltage for brown-in and brown-out protection.
2	GND	The ground of the IC.
3	VDD	Bias power input to the controller. A hold-up capacitor to GND is required.
4	COMP	Feedback input pin for Flyback QR controller. Connect to an opto-coupler directly.
5	VS	Voltage sensing input pin. Coupled to the auxiliary winding via a resistor divider to monitor the output voltage for OVP and UVP protection. This pin also detects the resonant valley to implement QR operation.
6	CS	Current sensing input pin. This pin sense the primary switch current for peak current control.
7	DRAIN	Drain terminal of the internal GaN.

BLOCK DIAGRAM

TBD

FUNCTIONAL DESCRIPTION

JW15158AS is an offline flyback converter with GaN intergrated, which features multi-mode quasi-resonant (QR) operation. The Quasi-Resonant (QR) with a limited frequency variation bounds the frequency band to overcome the inherent limitation of QR switching.

JW15158AS has an inherent frequency jittering mechanism to improve the EMI performance under QR operation.

1. Start-up

1.1. High Voltage Start-up at Drain Terminal

When HV is connected to rectified AC input, the internal JFET turns on and a HV current source starts to charge VDD cap. As soon as VDD reaches turn-on threshold V_{DD_ON} (16.5V), the internal startup circuit is disabled. The controller is enabled and the converter starts switching. The VDD turn-off threshold (V_{DD_OFF}) is 7.5V.

1.2 Soft-start

In the absence of a detected fault, the controller begins to work normally along with soft start. The internal soft-start time is within 4 ms with the feedback signal V_{COMP} rising gradually from the minimum level to the maximum level. Every restart up is followed by a soft start.

2. Normal Operation

After the controller start-up, it enters normal operation. JW15158AS realizes the output adjustment based on the feedback signal transmitting to the primary-side controller by the opto-coupler.

JW15158AS is a multi-mode QR converter with secondary-side regulation. According to the feedback signal V_{COMP} , the converter operates

in different modes for efficiency optimization. Fig.1 illustrates the frequency and peak current amplitude modulation modes. It can be divided into four operation regions as shown in Fig.1.

Under heavy load condition, the system operates in QR mode, the maximum switching frequency is limited to 110kHz. For medium-load range, the Pulse Frequency Modulation (PFM) is used and primary peak current is nearly fixed to achieve high efficiency. When the load is further reduced, switching frequency is fixed at 25kHz along with primary peak current varying from 65% to 25% of its maximum. When the system is at very light load condition, the control mode of JW15158AS changes to burst mode. When the voltage of COMP pin drops below V_{BUR_L} (0.5V), the drive stops. The drive will resume when the voltage of COMP pin rises back to V_{BUR_H} (0.6V). Otherwise the GaN remains at off state to minimize the switching loss and reduce the standby power consumption. Transitions between modes are automatically accomplished by the controller depending on the feedback signal, V_{COMP} .

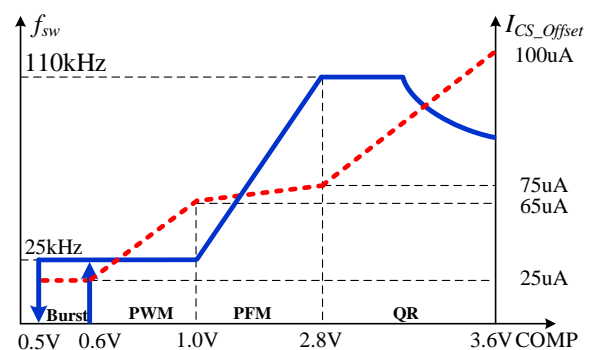

Fig.1 Frequency & Ipk Modulation

3. Other Functions and Features

3.1 Frequency Jittering

To achieve good EMI performance, frequency jittering method is integrated in JW15158AS. The frequency jittering is achieved by varying the switching frequency directly. The variation is $\pm 7\%$ around its normal value. The modulation cycle is determined by counting consecutive 32 switching cycles.

3.2 Lead Edge Blanking (LEB)

In order to avoid the premature termination of the switching pulse due to the parasitic capacitance, an internal leading edge blanking (LEB) is used between the CS pin and the current comparator input. The current comparator is disabled and can't turn off the internal GaN during the blanking time. The normal LEB time is around 150ns. Fig.2 shows the leading edge blanking time.

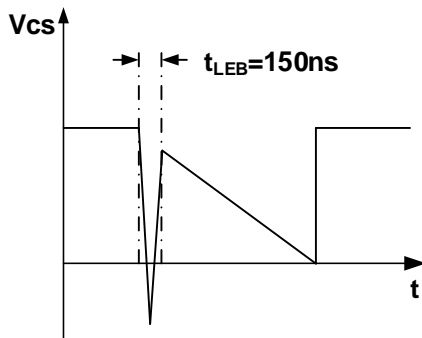

Fig.2 LEB Blanking

3.3 CCM Preventing

For JW15158AS, when the primary-side peak current exceeds the value decided by the feedback signal V_{COMP} , the switch turns off. When the controller detects ZCD signal and the switch period exceeds frequency-limit signal, the switch turns on. But the ZCD signal may not be detected during start-up moment because of low output voltage, then the switch will turn on after 80us to make sure the system operates in

DCM.

3.4 VS Blanking Time

VS spikes are affected by the amplitudes of I_{pk} and inductance, so VS blanking time should be set to vary with I_{pk} . Ensure that the secondary side conduction time is greater than the VS Blanking Time.

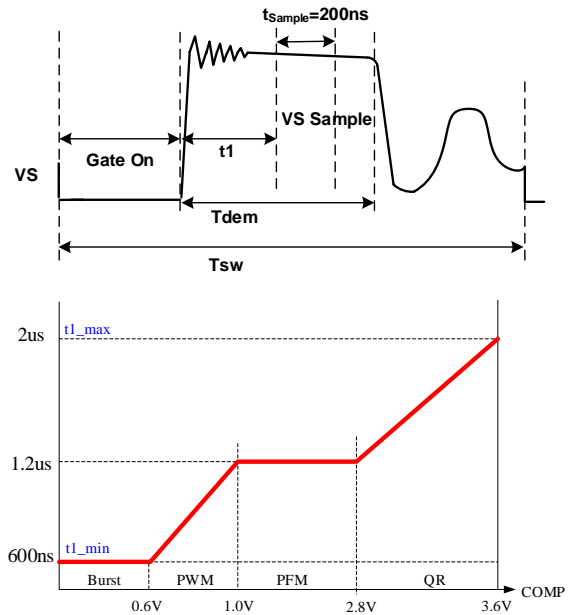

Fig.3 VS Blanking Time

4. Protection

4.1 CS Pin Open Protection

When CS pin is open, the internal bias current will flow to the parasitic capacitance on the CS pin, increasing the V_{CS} . If V_{CS} is above 2.0V, a CS pin open fault triggered.

4.2 Input Brown in / Brown out

JW15158AS senses HV voltage to realize brown in/out function. When HV voltage is higher than V_{BR_IN} (112V typically), a 5mA pull down current will be applied to VDD pin to make VDD hit V_{DD_OFF} . When VDD reaches V_{DD_ON} again, the controller starts switching. And the controller is disabled when HV voltage is lower

than V_{BR_OUT} (98V typically) for brown-out blanking time (70ms typically). The blanking time is set long enough to ignore a two cycle drop out. The timer starts counting once HV voltage drops below V_{BR_OUT} .

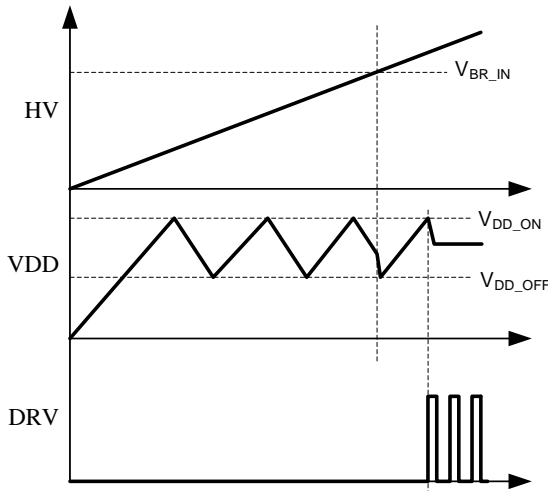

Fig.4 Brown-In at HV Pin

4.3 Output OVP (VS OVP)

The output over voltage protection is determined by the voltage feedback on the VS pin. If the voltage sample on VS exceeds 3V for three consecutive switching cycles, an VS_OVP fault is asserted, and then the device shuts

down, the UVLO reset and re-start fault cycle begins.

4.4 VS UVP

If the voltage sample on VS pin continues below the under-voltage protection threshold (0.5V) more than 120ms, a VS_UVP fault is asserted. When a VS_UVP fault is asserted, the device shuts down and the UVLO resets. In order to reduce the power consumption of the circuit, VDD needs to hit V_{DD_OFF} four times, and then the device restarts at the fifth cycle.

4.9 VDD OVP

If the voltage on VDD pin continues exceeds the over-voltage protection threshold (90V typically) more than 100us, a VDD OVP fault is asserted. The device shuts down, then the UVLO reset and re-start fault cycle begins.

4.10 Internal OTP

The internal over temperature protection threshold is 140°C. If the junction temperature of the device reaches this threshold, the device shuts down. When the junction temperature falls below 110°C, the device initiates the UVLO reset and re-starts fault cycle.

TAPE AND REEL INFORMATION

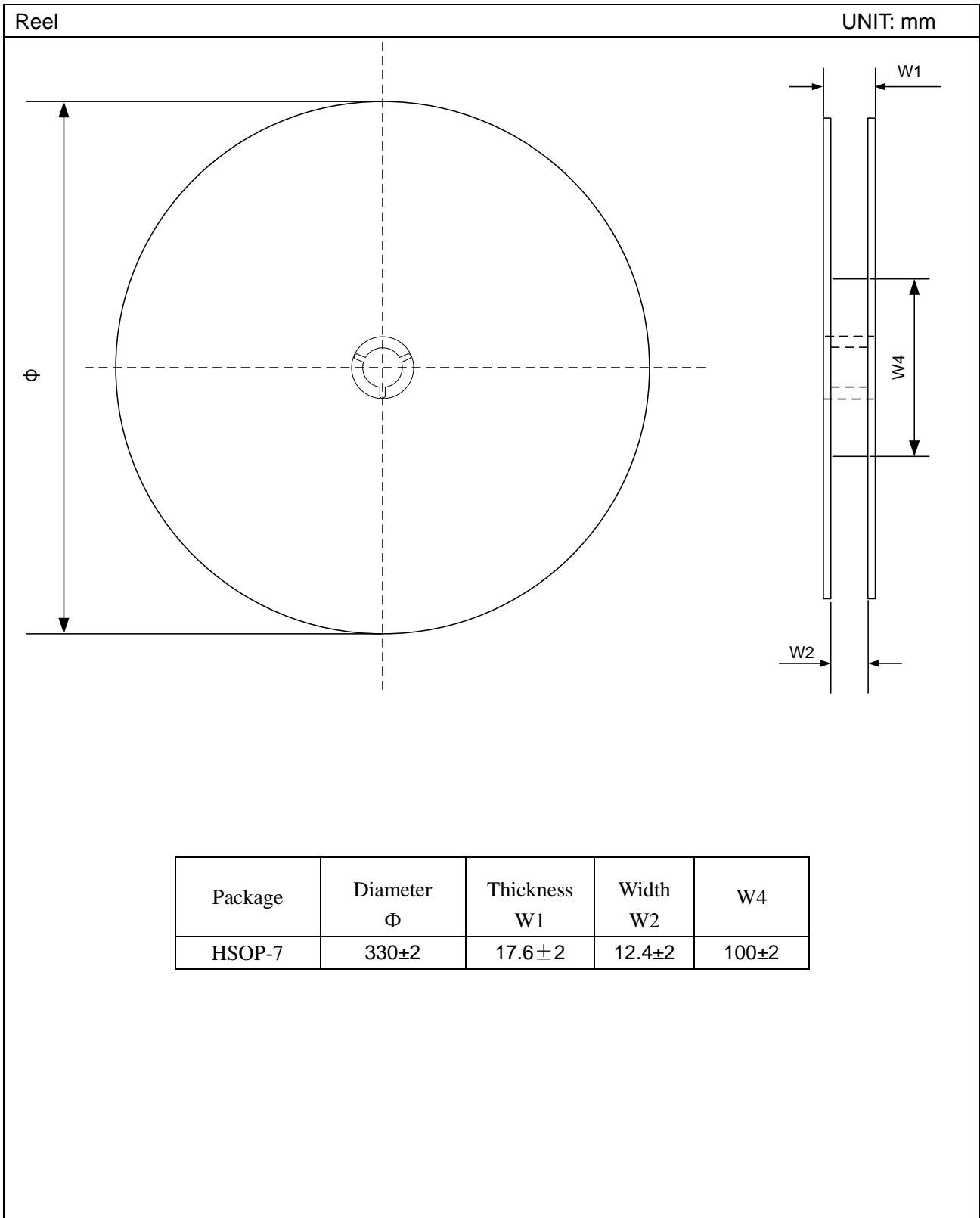

Carrier Tape

UNIT: mm

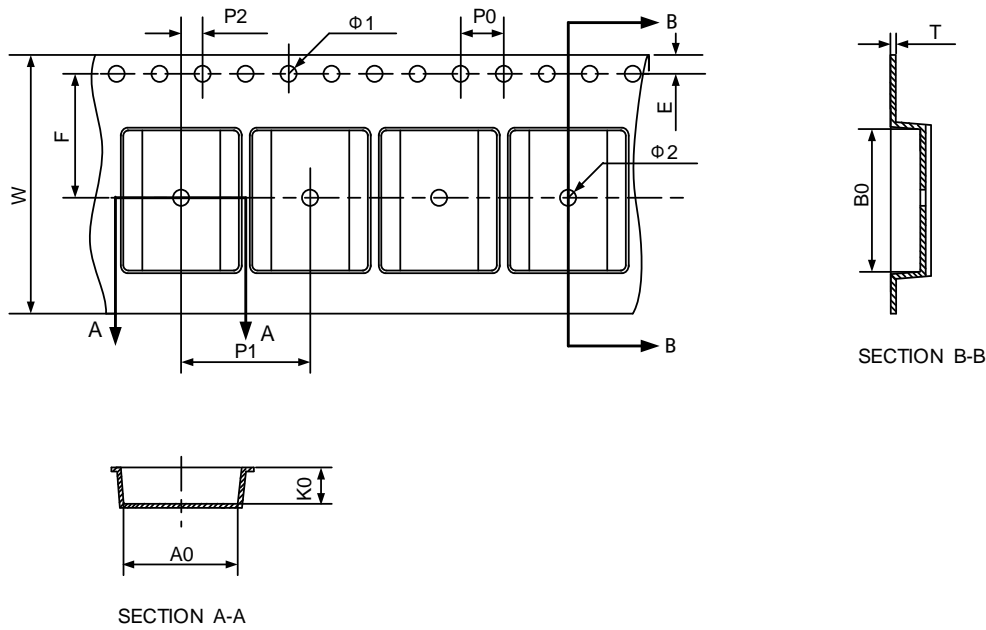

Note :

- 1) The carrier type is black, and colorless transparent.
- 2) Carrier camber is within 1mm in 100mm.
- 3) 10 pocket hole pitch cumulative tolerance:±0.20.
- 4) All dimensions are in mm.

Package	Tape dimensions (mm)											
	P0	P2	P1	A0	B0	W	T	K0	Φ1	Φ2	E	F
HSOP-7	4.0±0.10	2.0±0.05	8.0±0.10	6.40±0.10	6.60±0.10	12±0.30	0.25±0.10	1.7±0.10	1.55±0.10	1.55±0.10	1.75±0.10	5.50±0.10

PACKAGE OUTLINE

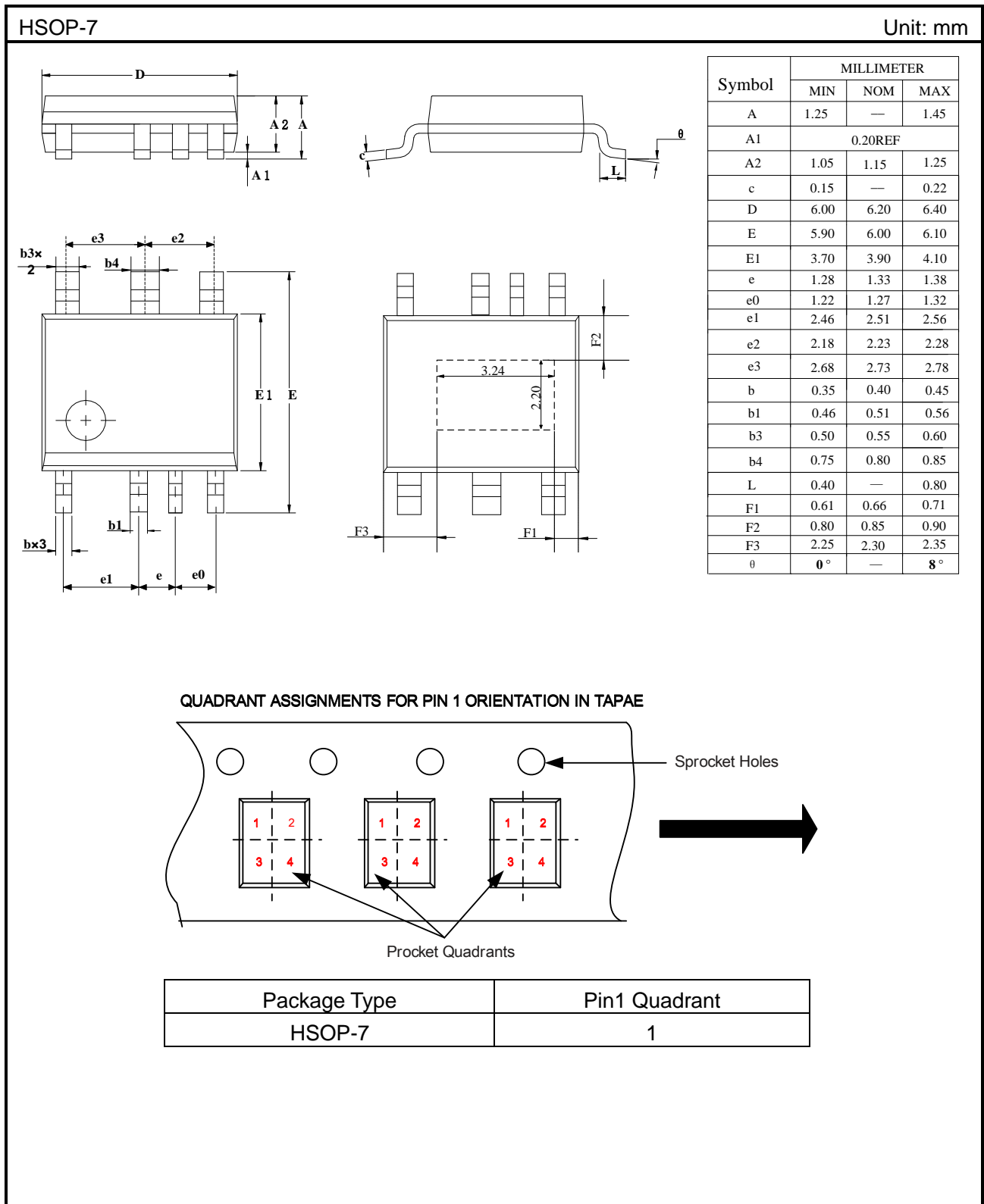

IMPORTANT NOTICE

- Joulwatt Technology Co.,Ltd reserves the right to make modifications, enhancements, improvements, corrections or other changes without further notice to this document and any product described herein.
- Any unauthorized redistribution or copy of this document for any purpose is strictly forbidden.
- Joulwatt Technology Co.,Ltd does not warrant or accept any liability whatsoever in respect of any products purchased through unauthorized sales channel.
- JOULWATT TECHNOLOGY CO.,LTD PROVIDES TECHNICAL AND RELIABILITY DATA (INCLUDING DATASHEETS), DESIGN RESOURCES (INCLUDING REFERENCE DESIGNS), APPLICATION OR OTHER DESIGN ADVICE, SAFETY INFORMATION AND OTHER RESOURCES, AND DISCLAIMS ALL WARRANTIES, EXPRESS AND IMPLIED, INCLUDING WITHOUT LIMITATION ANY IMPLIED WARRANTIES OF MERCHANTABILITY, FITNESS FOR A PARTICULAR PURPOSE OR NON-INFRINGEMENT OF THIRD PARTY INTELLECTUAL PROPERTY RIGHTS.

Copyright © 2022 JoulWatt

All rights are reserved by Joulwatt Technology Co.,Ltd

X-ON Electronics

Largest Supplier of Electrical and Electronic Components

Click to view similar products for [Switching Voltage Regulators](#) category:

Click to view products by [JoulWatt](#) manufacturer:

Other Similar products are found below :

[FAN53610AUC33X](#) [FAN53611AUC123X](#) [EN6310QA](#) [160215](#) [R3](#) [KE177614](#) [FAN53611AUC12X](#) [MAX809TTR](#) [NCV891234MW50R2G](#)
[AST1S31PUR](#) [NCP81203PMNTXG](#) [NCP81208MNTXG](#) [PCA9412AUKZ](#) [NCP81109GMNTXG](#) [NCP3235MNTXG](#) [NCP81109JMNTXG](#)
[NCP81241MNTXG](#) [NTE7223](#) [NTE7222](#) [NTE7224](#) [L6986FTR](#) [MPQ4481GU-AEC1-P](#) [MP8756GD-P](#) [MPQ2171GJ-P](#) [MPQ2171GJ-AEC1-P](#)
[N JW4153U2-A-TE2](#) [MP2171GJ-P](#) [MP28160GC-Z](#) [MPM3509GQVE-AEC1-P](#) [XDPE132G5CG000XUMA1](#) [LM60440AQRPKRQ1](#)
[MP5461GC-P](#) [IW673-20](#) [NCV896530MWATXG](#) [MPQ4409GQBE-AEC1-P](#) [S-19903DA-A8T1U7](#) [S-19903CA-A6T8U7](#) [S-19903CA-](#)
[S8T1U7](#) [S-19902BA-A6T8U7](#) [S-19902CA-A6T8U7](#) [S-19902AA-A6T8U7](#) [S-19903AA-A6T8U7](#) [S-19902AA-S8T1U7](#) [S-19902BA-A8T1U7](#)
[AU8310](#) [LMR23615QDRRRQ1](#) [LMR33630APAQRNXRQ1](#) [LMR33630APCQRNXRQ1](#) [LMR36503R5RPER](#) [LMR36503RFRPER](#)