

Parameters Subject to Change Without Notice

DESCRIPTION

The JW[®]1965A/JW1965B/JW1965C (JW1965X series) is a constant current LED driver which applies to single stage Boost power factor corrected LED drivers.

JW1965X series integrates high voltage power source, and can be supplied by output voltage directly, auxiliary winding and VCC capacitor are not needed.

Patented current sensing and digital compensation technics ensure a unit power factor and high accuracy output current. The critical conduction mode operation reduces the switching losses and increases the efficiency.

JW1965X series has multi-protection functions which largely enhance the safety and reliability of the system, including LED open protection, freewheeling diode open protection and over-temperature protection.

Company's Logo is Protected, "JW" and "JOULWATT" are Registered

Trademarks of JoulWatt technology Inc.

FEATURES

- No auxiliary winding and VCC capacitor
- Supplied from output voltage directly
- High current accuracy of line and load regulation
- Internal compensation PFC technics
- Critical conduction mode
- High efficiency over wide operating range
- LED open protection
- Freewheeling diode open protection
- Over-temperature protection
- SOP7 and DIP7 package

APPLICATIONS

- Non-isolation Offline LED driver

TYPICAL APPLICATION

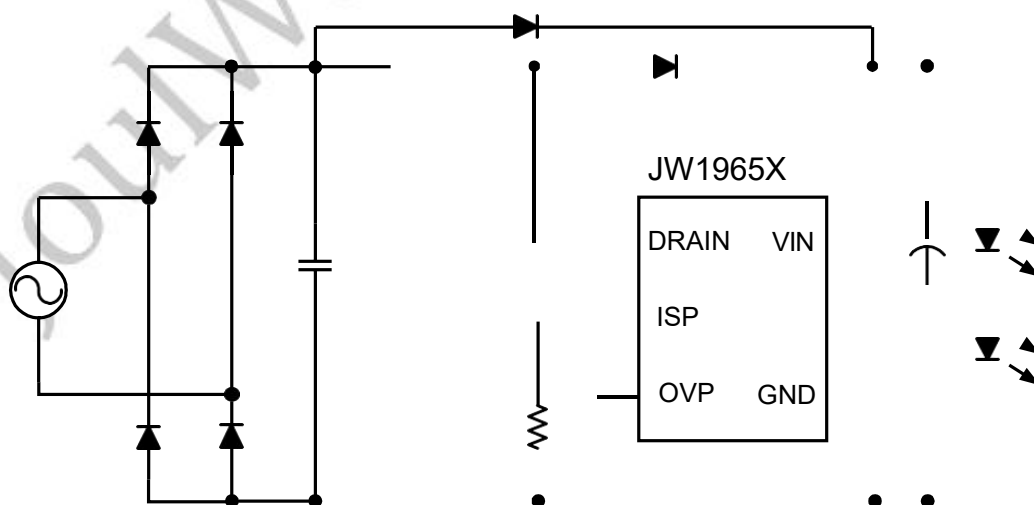

ORDER INFORMATION

DEVICE ¹⁾	PACKAGE	TOP MARKING ²⁾
JW1965ASOPA#TRPBF	SOP7	JW1965A YWL L L L L
JW1965BSOPA#TRPBF	SOP7	JW1965B YWL L L L L
JW1965BDIPA#PBF	DIP7	JW1965B YWL L L L L
JW1965CDIPA#PBF	DIP7	JW1965C YWL L L L L

Notes :

- JW # TRPBF I PB Free Tape and Reel (If " TR " is not shown, it means tube)
 1) JW YWL L L L L
 2) Line1: Product code of JWXXXX Line2: Lot number
 Joulwatt LOGO Week code Year code

DEVICE INFORMATION

JW1965ASOPA#TRPBF	650V	6.8Ω
JW1965BSOPA#TRPBF	600V	1.8Ω
JW1965CDIPA#PBF	650V	1Ω

PIN CONFIGURATION

TOP VIEW

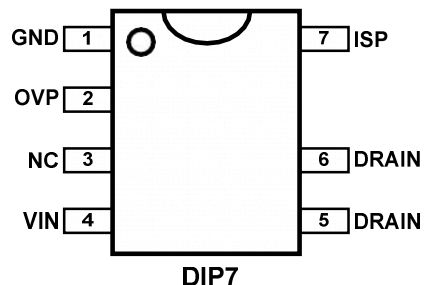
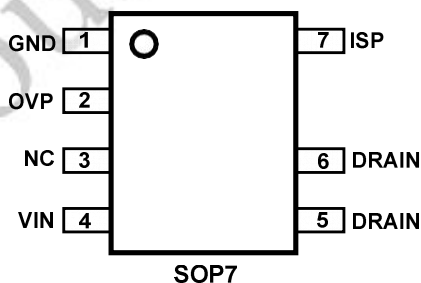

ABSOLUTE MAXIMUM RATING¹⁾

VIN Voltage.....	V
ISP Voltage.....	V
Junction Temperature ^{2) 3)}	150°C
Lead Temperature.....	260°C
Storage Temperature.....	-65°C to +150°C
ESD Susceptibility (Human Body Model).....	kV

RECOMMENDED OPERATING CONDITIONS

VIN Voltage.....	V to 500V
Operating Junction Temp (T _J).....	-40°C to 125°C

THERMAL PERFORMANCE⁴⁾

	θ_{JA}	θ_{JC}	θ
SOP7.....	96		45°C/W
DIP7.....	80		45°C/W

Note :

- 1) Exceeding these ratings may damage the device.
- 2) Guarantees robust performance from -40°C to 150°C junction temperature. The junction temperature range specification is assured by design, characterization and correlation with statistical process controls.
- 3) Includes thermal protection that is intended to protect the device in overload conditions. Thermal protection is active when junction temperature exceeds the maximum operating junction temperature. Continuous operation over the specified absolute maximum operating junction temperature may damage the device.
- 4) Measured on JESD51-7, 4-layer PCB.

ELECTRICAL CHARACTERISTICS

T_A=25°C, unless otherwise stated.

Item	Symbol	Condition	Min.	Typ.	Max.	Units
VIN Start-Up Voltage	V _{IN_ST}			30		V
VIN Quiescent Current	I _{INQ}	GATE floating		320	450	μA
ISP Sample Reference	V _{REF}			100		mV
Minimum On Time of MOSFET ⁵⁾	T _{ON_MIN}			1.2		μS
Maximum On Time of MOSFET	T _{ON_MAX}			25		μS
Minimum Off Time of MOSFET ⁵⁾	T _{OFF_MIN}			2		μS
Maximum Off Time of MOSFET ⁵⁾	T _{OFF_MAX}			400		μS
Maximum Switch Frequency ⁵⁾	f _{MAX}			150		KHz
Switching Period of VINL ⁵⁾	T _{VINL}			65		μS
MOS R _{dson} ⁵⁾	JW1965A	V _{gs} =10V		6.8		Ω
	JW1965B			1.8		
	JW1965C			1		
Breakdown Voltage	JW1965A	BV	650			V
	JW1965B		600			
	JW1965C		650			
ISP Over Voltage Protection Threshold	V _{ISP_MAX}			1.4		V
Vo Over Voltage Protection Threshold ⁵⁾	V _{O_OVP1}	V _{OVP} =2V		300		V
	V _{O_OVP2}	V _{OVP} =4.8V		580		V
	V _{O_OVP3}	V _{OVP} =0V		540		V
Thermal Protection Threshold ⁵⁾	T _{OTP}			150		°C

5) Guaranteed by design

PIN DESCRIPTION

Pin No.	Name	Description
1	GND	Chip ground.
2	OVP	Set OVP threshold.
3	NC	No Connection
4	VIN	High voltage input.
5,6	DRAIN	Drain of the MOSFET
7	ISP	Current sense.

BLOCK DIAGRAM

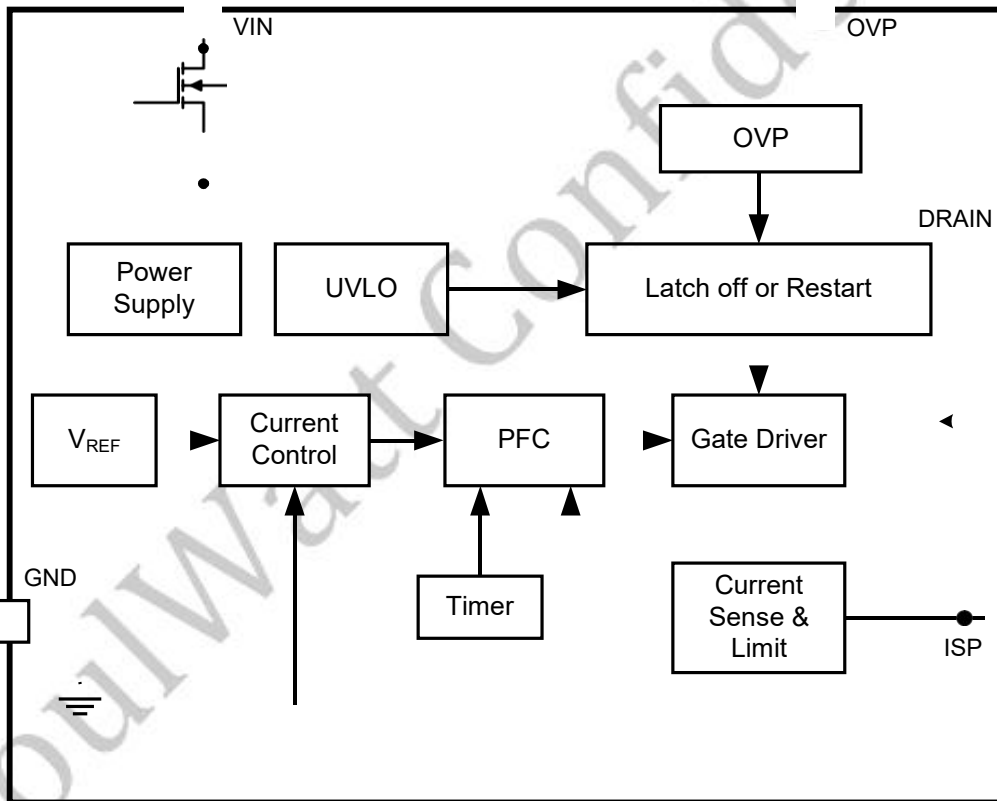

FUNCTIONAL DESCRIPTION

The JW1965X series is a constant current LED driver which applies to non-isolation Boost LED system with power factor correction. JW1965X series can achieve excellent line and load regulation, high efficiency and low system cost with few peripheral components.

Start Up

JW1965X series is supplied by output voltage directly. When VIN reaches VIN start up voltage (VIN_ST), the chip begins to switch. Once VIN is lower than VIN_ST, JW1965X series stops switching.

Constant Current Control

The JW1965X series controls the output current from the information of the sensing resistor voltage. The output LED mean current can be calculated as:

$$I_{LED} = V_{REF} / R_{SNS}$$

Where

VREF – ISP sample reference;

RSNS – The sensing resistor connected between ISP and GND.

Critical Conduction Mode Operation

JW1965X series works in the Critical conduction mode of the inductor current. When the power MOSFET is turned on, the inductor current begins to increase from zero. The turn on time of the MOSFET can be calculated as:

$$T_{ON} = I_{PK} \times L / V_{IN}$$

Where,

L –inductance.

IPK – peak current in one switch cycle.

VIN – input voltage after rectification and filtering.

When the power MOSFET is turned off, the inductor current begins to decrease. The power

MOSFET turns on again when the inductor current is zero. The turn off time of the MOSFET can be calculated as:

$$T_{OFF} = I_{PK} \times L / (V_{OUT} - V_{IN})$$

Where,

VOUT – output LED voltage.

And the inductance of the system can be calculated as:

$$L = V_{IN} \times (V_{OUT} - V_{IN}) / (f \times I_{PK} \times V_{OUT})$$

Where, f is the switching frequency of the step-down system.

LED Over Temperature Protection

When the internal temperature of the chip exceeds the thermal Protection Threshold(TOTP), JW1965X series decreases LED current to help the chip cooling.

LED Open Protection

The OVP threshold (VO_OVP) is set by the OVP pin. When Vo is higher than VO_OVP, LED open protection is triggered and the chip stops switching for 800ms. The following table shows the VO_OVP design guide:

OVP Pin	VO_OVP(V)
Connected with 510 KΩ resistor	VO_OVP1
Not connected	VO_OVP2
Short connected	VO_OVP3

PCB Design

When designing the PCB of the JW1965X series system, please follow the directions:

1. Make the area of the power loop as small as possible in order to reduce the EMI radiation.
2. The chip should be far away from the heating element, such as the power inductor.

REFERENCE DESIGN

This reference design is suitable for 15W non-isolated Boost LED driver, using JW1965A, with high efficiency, excellent line regulation.

Reference :

V_{IN} : 90VAC~264VAC

V_{OUT} : 420V

I_{OUT} : 30mA

PF: >0.9

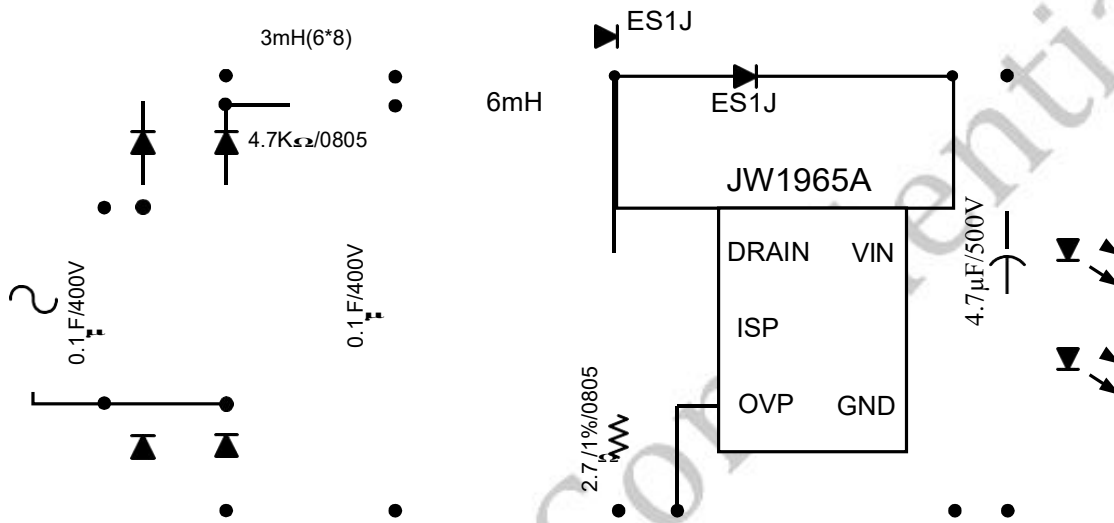

PACKAGE OUTLINE

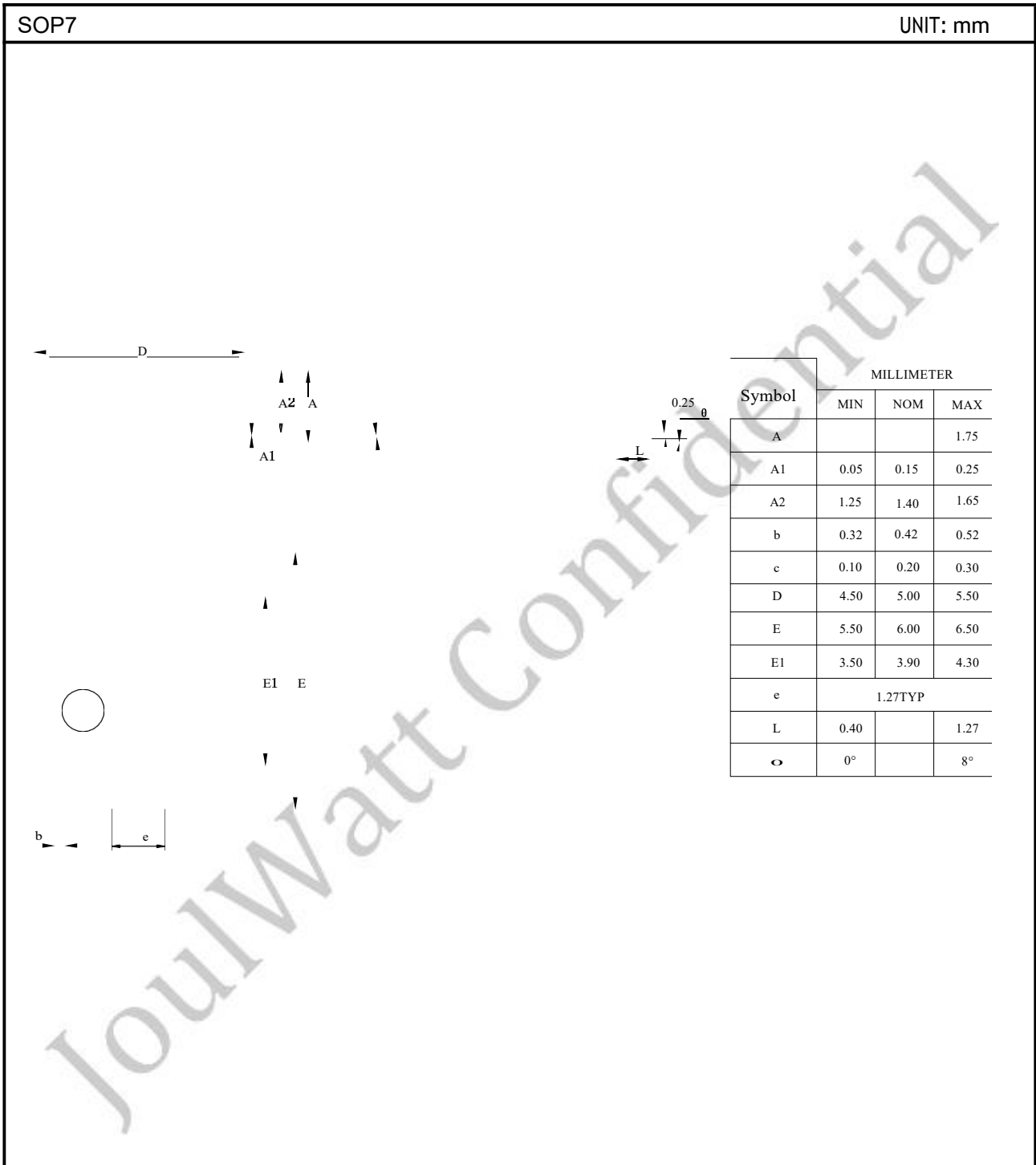

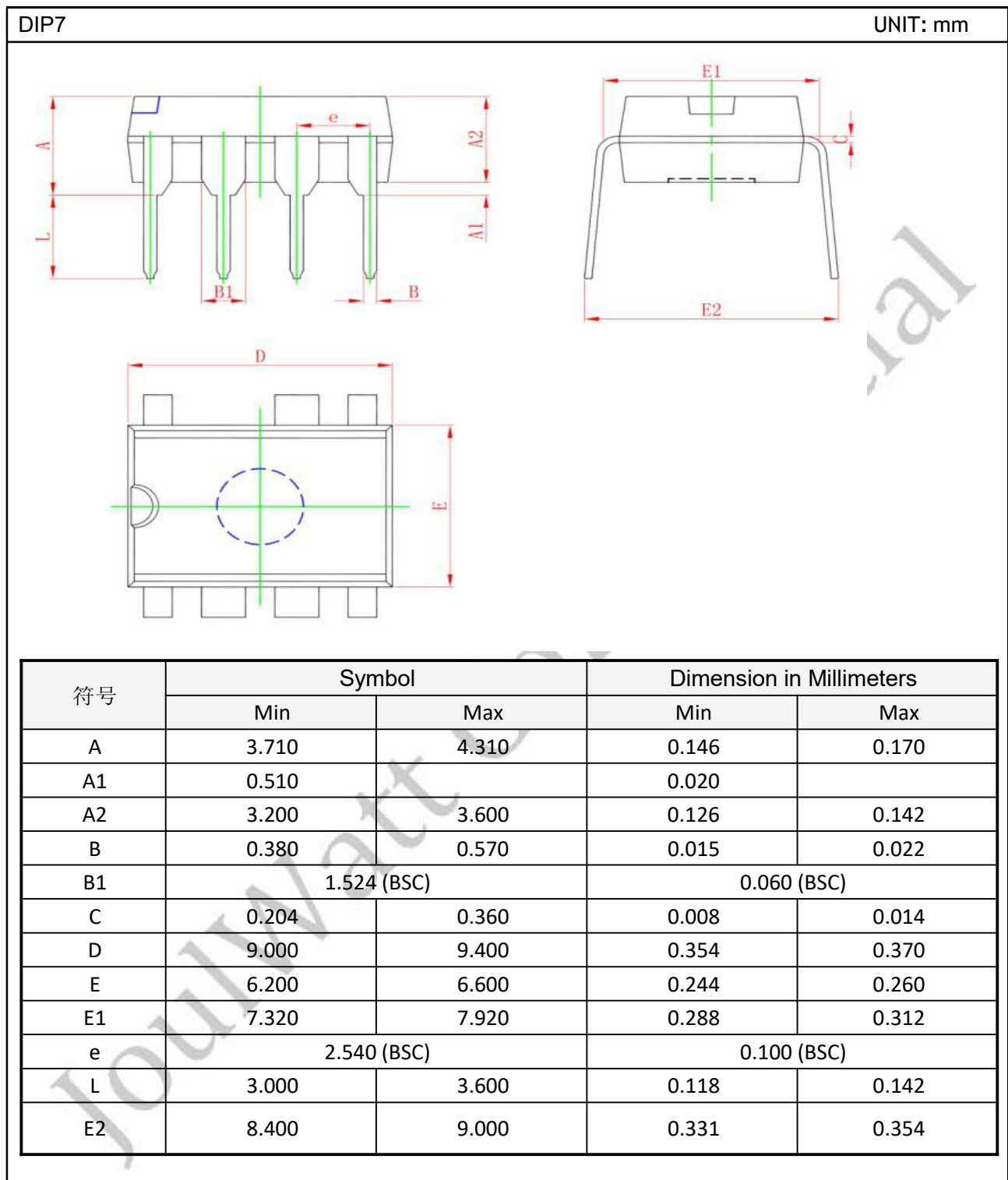

IMPORTANT NOTICE

- Joulwatt Technology Inc. reserves the right to make modifications, enhancements, improvements, corrections or other changes without further notice to this document and any product described herein.
- Any unauthorized redistribution or copy of this document for any purpose is strictly forbidden.
- Joulwatt Technology Inc. does not warrant or accept any liability whatsoever in respect of any products purchased through unauthorized sales channel.

JoulWatt Confidential

Copyright © 2019 JW1965X series Incorporated.

All rights are reserved by Joulwatt Technology Inc.

X-ON Electronics

Largest Supplier of Electrical and Electronic Components

Click to view similar products for [LED Display Drivers](#) category:

Click to view products by [JoulWatt](#) manufacturer:

Other Similar products are found below :

[STP16CPP05XTTR](#) [SCT2027CSSG](#) [KP22306WGA](#) [WS9088AS7P](#) [GN1628T](#) [BCT3236EGH-TR](#) [HT1628BRWZ](#) [KP1192SPA](#) [KP1182SPA](#)
[KP1262FSPA](#) [KP1072LSPA](#) [KP1191SPA](#) [KP18001WPA](#) [KP1221SPA](#) [GN1640T](#) [MBI5253GP-A](#) [MBI5124GM-B](#) [WS90561T](#) [S7P](#)
[WS9821B](#) [S7P](#) [WS9032GS7P](#) [74HC595D](#) [PJL4115SR](#) [SY8718A1ADC](#) [TM1651\(TA2007\)](#) [TM1616\(TA1323C\)](#) [TM1617\(TA1323C\)](#)
[TM1628A](#) [TM1834](#) [TM512AC](#) [TM512ADH](#) [TM1923](#) [TM1805](#) [TM1914A](#) [TM1829](#) [TM1668\(TA1323C\)](#) [AW9963CSR](#) [WS2811M](#)
[SY8703BABC](#) [SY7311AADC](#) [HT8402ARTZ](#) [MT7860](#) [OB3638CPA](#) [JW1965BSOPA#TRPBF](#) [JW1680OSOPB#TRPBF](#) [TM3100](#) [MT7938](#)
[SM2255E](#) [MT7712SH](#) [STI9287CA](#) [U6113](#)