

Parameters Subject to Change Without Notice

DESCRIPTION

The JW[®]1967A/JW1967B/JW1967C /JW1967EH (JW1967X series) is a constant current LED regulator which apply to single stage step-down power factor corrected LED drivers.

JW1967X series integrates high voltage power source, and can be supplied by line voltage directly, auxiliary winding and VCC capacitor are not needed.

Patented current sensing and digital compensation technics ensure a unit power factor and high accuracy output current. The critical conduction mode operation reduces the switching losses and increases the efficiency.

JW1967X series has multi-protection functions which largely enhance the safety and reliability of the system, including LED open protection, LED short protection and over-temperature protection.

Company's Logo is Protected, "JW" and "JOULWATT" are Registered Trademarks of JoulWatt technology Inc.

FEATURES

- No auxiliary winding and VCC capacitor
- Supplied from line voltage directly
- High current accuracy of line and load regulation
- Internal compensation PFC technics
- Critical conduction mode
- High efficiency over wide operating range
- High voltage power MOSFET integrated
- LED open protection
- LED short protection
- Internal over-temperature protection
- SOP7 and DIP7 package

APPLICATIONS

- Non-isolation Offline LED driver

TYPICAL APPLICATION

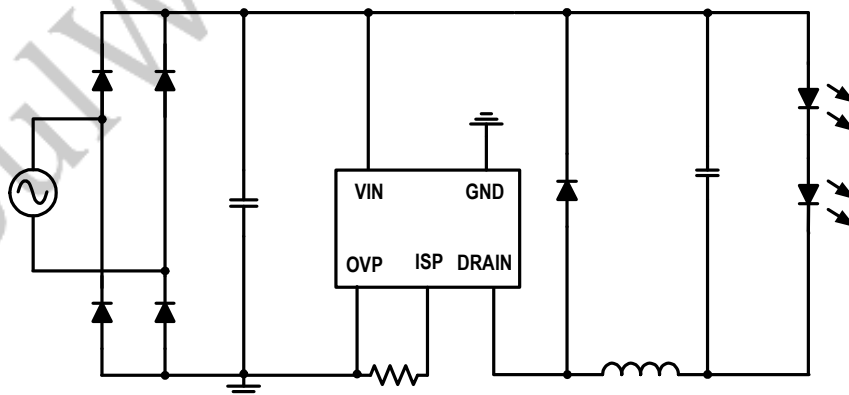

ORDER INFORMATION

DEVICE ¹⁾	PACKAGE	TOP MARKING ²⁾
JW1967ASOPA#TRPBF	SOP7	JW1967A YW□□□□□
JW1967BSOPA#TRPBF	SOP7	JW1967B YW□□□□□
JW1967CSOPA#TRPBF	SOP7	JW1967C YW□□□□□
JW1967EHSOPA#TRPBF	SOP7	JW1967EH YW□□□□□
JW1967EHDIPA#PBF	DIP7	JW1967EH YW□□□□□

Notes :

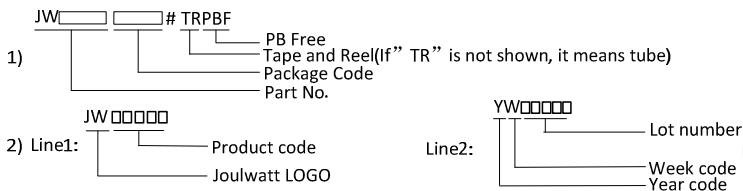

DEVICE INFORMATION

DEVICE	MOS BV	MOS RDSON
JW1967ASOPA#TRPBF	500V	8.5Ω
JW1967BSOPA#TRPBF	550V	5.5Ω
JW1967CSOPA#TRPBF	500V	3Ω
JW1967EHSOPA#TRPBF	600V	1.8Ω

PIN CONFIGURATION

TOP VIEW

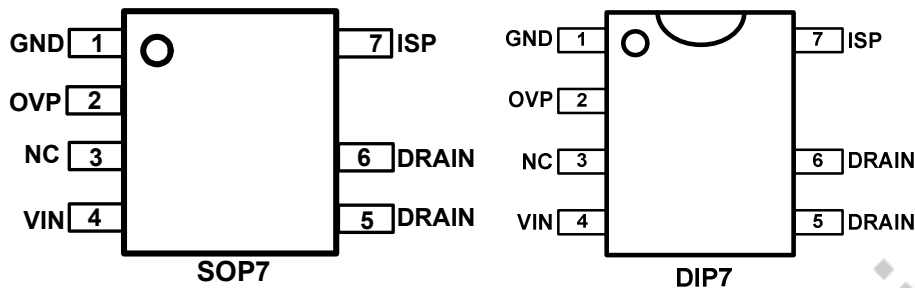

ABSOLUTE MAXIMUM RATING¹⁾

VIN Voltage.....	700V
OVP,ISP Voltage.....	6V
Junction Temperature ^{2) 3)}	150°C
Lead Temperature.....	260°C
Storage Temperature.....	-65°C to +150°C
ESD Susceptibility (Human Body Model)	2kV

RECOMMENDED OPERATING CONDITIONS

VIN Voltage.....	30V to 500V
Operating Junction Temp (T _J)	-40°C to 125°C

Minimum Output Voltage(V_{O_MIN})

JW1967A/B/EH.....	30V
JW1967C.....	36V

THERMAL PERFORMANCE⁴⁾

	θ_{JA}	θ_{JC}
SOP7.....	96.....	45°C/W
DIP7.....	80.....	45°C/W

Note:

- 1) Exceeding these ratings may damage the device.
- 2) Guarantees robust performance from -40°C to 150°C junction temperature. The junction temperature range specification is assured by design, characterization and correlation with statistical process controls.
- 3) Includes thermal protection that is intended to protect the device in overload conditions. Thermal protection is active when junction temperature exceeds the maximum operating junction temperature. Continuous operation over the specified absolute maximum operating junction temperature may damage the device.
- 4) Measured on JESD51-7, 4-layer PCB.

ELECTRICAL CHARACTERISTICS

<i>T_A=25 °C, unless otherwise stated.</i>							
Item	Symbol	Condition	Min.	Typ.	Max.	Units	
POWER SUPPLY							
VIN Start-Up Voltage	V _{IN_ST}			7	8	V	
VIN Quiescent Current	I _{INQ}			320	450	µA	
CURRENT REGULATION							
ISP Sample Reference	V _{REF}		192	200	207	mV	
Minimum On Time of MOSFET ⁵⁾	T _{ON_MIN}			1.2		µS	
Maximum On Time of MOSFET	T _{ON_MAX}		19	25	34	µS	
Minimum Off Time of MOSFET ⁵⁾	T _{OFF_MIN}			2		µS	
Maximum Off Time of MOSFET ⁵⁾	T _{OFF_MAX}			400		µS	
Maximum Switch Frequency ⁵⁾	f _{MAX}			80		KHz	
Switching Period of VINL ⁵⁾	T _{VINL}			65		µS	
PROTECTION							
ISP Over Voltage Protection Threshold	V _{ISP_MAX}		1.08	1.2	1.32	V	
Vo Over Voltage Protection Threshold ⁵⁾	V _{O_OVP1}	V _{OVP} =2V	65	74	82	V	
	V _{O_OVP2}	V _{OVP} =4.8V	102	114	126	V	
	V _{O_OVP3}	V _{OVP} =0V	156	174	192	V	
Thermal Protection Threshold ⁵⁾	T _{OTP}		140	150		°C	
MOS							
MOS R _{dson} ⁵⁾	JW1967A	R _{dson}	V _{gs} =10V		8.5	10	Ω
	JW1967B				5.5	6.5	Ω
	JW1967C				3	3.5	Ω
	JW1967EH				1.8	2.2	Ω
MOS Saturation Current ⁵⁾	JW1967A	I _d	V _{gs} =10V	1.6			A
	JW1967B			2			A
	JW1967C			6			A
	JW1967EH			8			A
Breakdown Voltage	JW1967A/C	BV		500			V
	JW1967B			550			V
	JW1967EH			600			V

5) Guaranteed by design

PIN DESCRIPTION

Pin No.	Name	Description
1	GND	Chip ground.
2	OVP	Set OVP threshold.
3	NC	Not connect.
4	VIN	Line voltage input.
5,6	DRAIN	DRAIN of the MOSFET
7	ISP	Output current sense.

BLOCK DIAGRAM

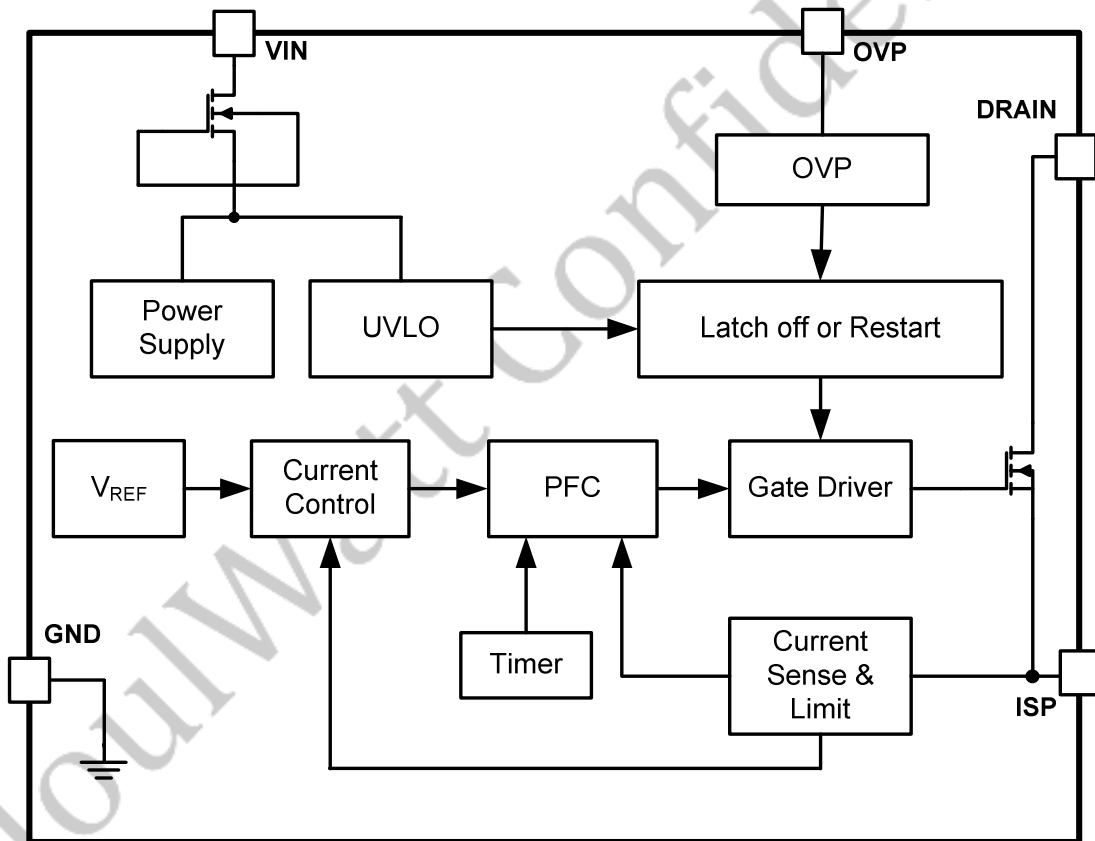

FUNCTIONAL DESCRIPTION

The JW1967X series is a constant current LED driver which applies to non-isolation step-down LED system with power factor correction. JW1967X series can achieve excellent line and load regulation, high efficiency and low system cost with few peripheral components.

Start Up

JW1967X series is supplied by line voltage directly. When VIN reaches VIN start up voltage (VIN_ST), the chip begins to switch. Once VIN is lower than VIN under voltage lockout, JW1967X series stops switching.

Constant Current Control

The JW1967X series controls the output current from the information of the sensing resistor voltage. The output LED mean current can be calculated as:

$$I_{LED} = V_{REF} / R_{SNS}$$

Where

VREF – ISP sample reference;

RSNS – The sensing resistor connected between ISP and GND.

Critical Conduction Mode Operation

JW1967X series works in the Critical conduction mode of the inductor current. When the power MOSFET is turned on, the inductor current begins to increase from zero. The turn on time of the MOSFET can be calculated as:

$$T_{ON} = I_{PK} \times L / (V_{IN} - V_{OUT})$$

Where,

L –inductance.

IPK – peak current in one switch cycle.

VIN – input voltage after rectification and

filtering.

VOUT – output LED voltage.

When the power MOSFET is turned off, the inductor current begins to decrease. The power MOSFET turns on again when the inductor current is zero. The turn off time of the MOSFET can be calculated as:

$$T_{OFF} = I_{PK} \times L / V_{OUT}$$

And the inductance of the system can be calculated as:

$$L = V_{OUT} \times (V_{IN} - V_{OUT}) / (f \times I_{PK} \times V_{IN})$$

Where, f is the switching frequency of the step-down system.

Over Temperature Protection

When internal temperature of the chip exceeds Thermal Protection Threshold(TOTP), JW1967X series decrease LED current to help the chip cooling.

LED Open Protection

The OVP threshold (VO_OVP) is set by the OVP pin. When Vo is higher than VO_OVP, LED open protection is triggered and the chip stops switching for 800ms. The following table shows the VO_OVP design guide:

OVP Pin	VO_OVP(V)
Connected with 510KΩ resistor	VO_OVP1
Not connected	VO_OVP2
Short connected	VO_OVP3

APPLICATION NOTES

1: R_{VIN} and V_{O_OVP} design guide

To enhance the surge capability, VIN pin of JW1967X series should be connected to input capacitor by a resistor R_{VIN}(0805/1206 package, no less than 4.7KΩ is recommended). Larger R_{VIN} means better surge capability but please note that too large R_{VIN} may decrease the drive current, and the maximum R_{VIN} is limited by

$$(V_o-15V)/R_{VIN}>3mA$$

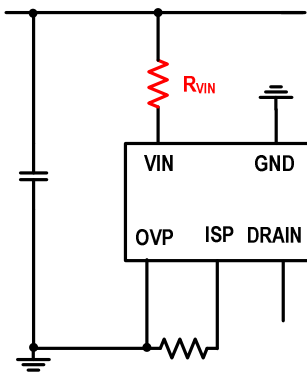

R_{VIN} and V_{O_OVP} design guide is shown in following Tab:

V _{O_PEAK} (V)	Recommended R _{VIN} (Ω)	OVP(V)
36~45	5.1K	V _{O_OVP1}
46~50	10K	
51~100	10K~15K	V _{O_OVP2}
101~145	10K~20K	V _{O_OVP3}

Where V_{O_PEAK} is the peak value of the Vo, the ripple of the Vo and suitable margin should be taken into consideration when designing the OVP.

2: PCB Design

When designing the PCB of the JW1967X series system, please follow the directions:

1. Make the area of the power loop as small as possible in order to reduce the EMI radiation.
2. The chip should be far away from the heating element, such as the power inductor and the freewheel diode.

REFERENCE DESIGN

This reference design is suitable for 5 ~ 9W non-isolated Step-down LED driver, using JW1967B, with high efficiency, excellent line regulation.

Reference :

V_{IN}: 90VAC~264VAC

V_{OUT}: 40~75V

I_{OUT}: 100mA

PF: >0.9

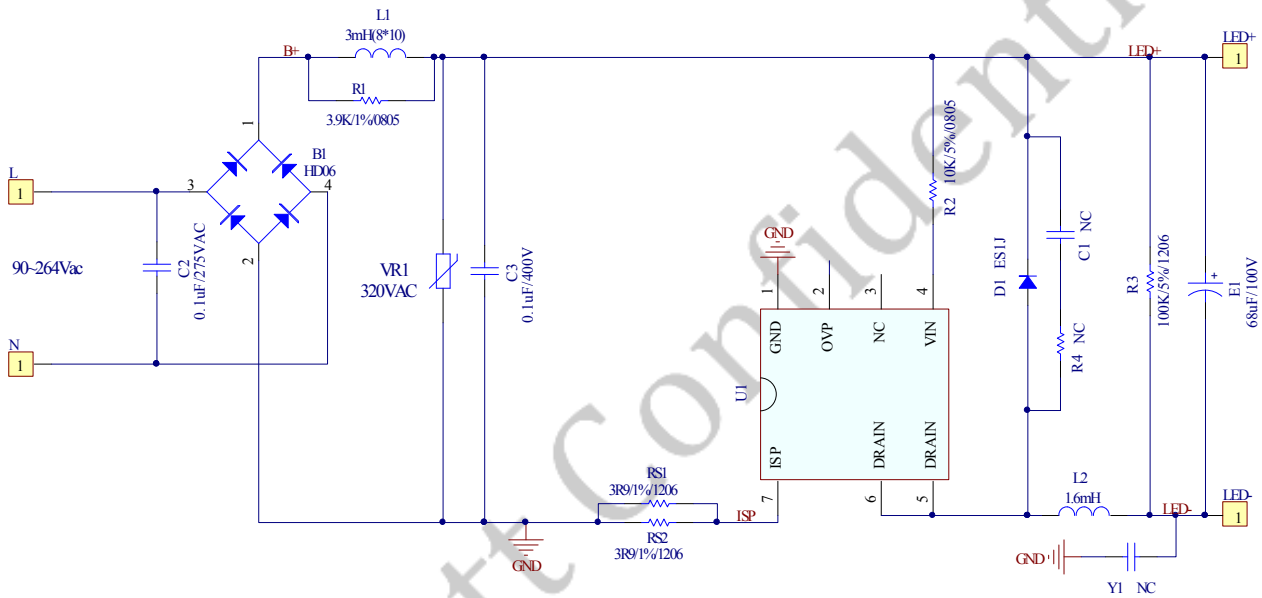

PACKAGE OUTLINE

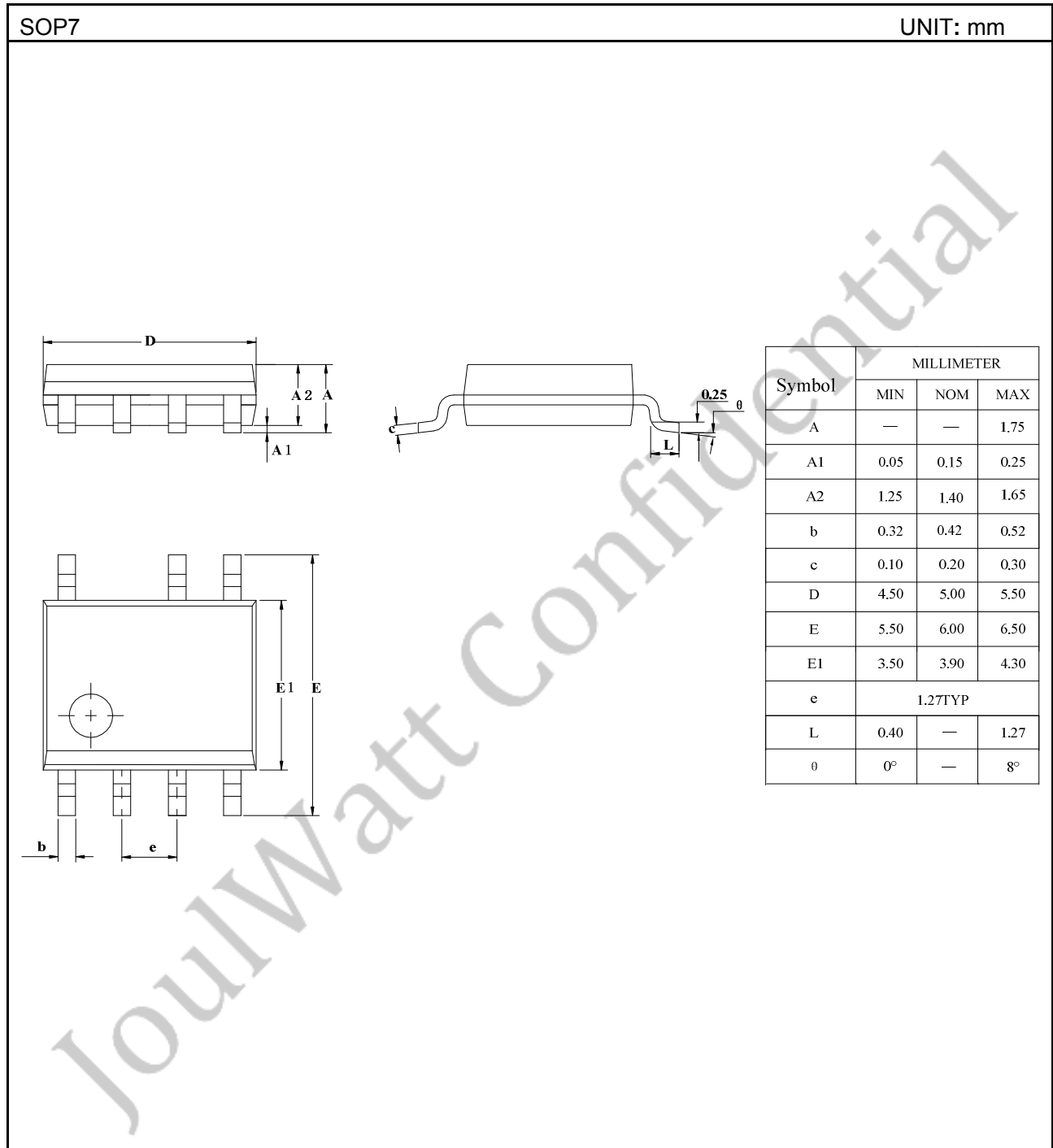

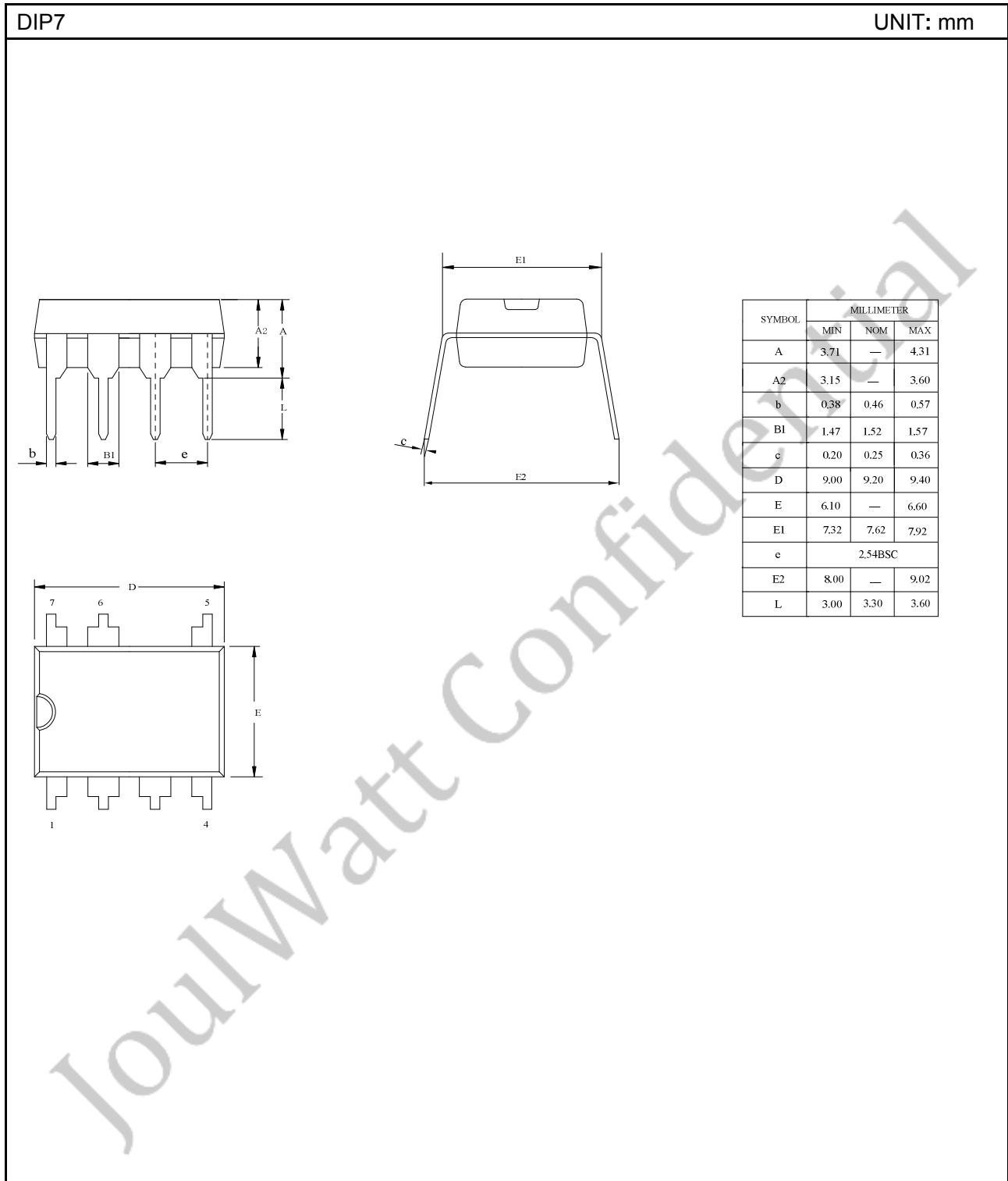

IMPORTANT NOTICE

- Joulwatt Technology Inc. reserves the right to make modifications, enhancements, improvements, corrections or other changes without further notice to this document and any product described herein.
- Any unauthorized redistribution or copy of this document for any purpose is strictly forbidden.
- Joulwatt Technology Inc. does not warrant or accept any liability whatsoever in respect of any products purchased through unauthorized sales channel.

JoulWatt Confidential

Copyright © 2018 JW1967X series Incorporated.

All rights are reserved by Joulwatt Technology Inc.

X-ON Electronics

Largest Supplier of Electrical and Electronic Components

Click to view similar products for [LED Display Drivers](#) category:

Click to view products by [JoulWatt](#) manufacturer:

Other Similar products are found below :

[STP16CPP05XTTR](#) [SCT2027CSSG](#) [KP22306WGA](#) [WS9088AS7P](#) [GN1628T](#) [BCT3236EGH-TR](#) [HT1628BRWZ](#) [KP1192SPA](#) [KP1182SPA](#)
[KP1262FSPA](#) [KP1072LSPA](#) [KP1191SPA](#) [KP18001WPA](#) [KP1221SPA](#) [GN1640T](#) [MBI5253GP-A](#) [MBI5124GM-B](#) [WS90561T](#) [S7P](#)
[WS9821B](#) [S7P](#) [WS9032GS7P](#) [74HC595D](#) [PJL4115SR](#) [SY8718A1ADC](#) [TM1651\(TA2007\)](#) [TM1616\(TA1323C\)](#) [TM1617\(TA1323C\)](#)
[TM1628A](#) [TM1834](#) [TM512AC](#) [TM512ADH](#) [TM1923](#) [TM1805](#) [TM1914A](#) [TM1829](#) [TM1668\(TA1323C\)](#) [AW9963CSR](#) [WS2811M](#)
[SY8703BABC](#) [SY7311AADC](#) [HT8402ARTZ](#) [MT7860](#) [OB3638CPA](#) [JW1965BSOPA#TRPBF](#) [JW1680OSOPB#TRPBF](#) [TM3100](#) [MT7938](#)
[SM2255E](#) [MT7712SH](#) [STI9287CA](#) [U6113](#)