

Features

- Maximum output current is 1.2A
- Range of operation input voltage: Max 15V
- Line regulation: 0.03%/V (typ.)
- Standby current: 2mA (typ.)
- Load regulation: 0.2%/A (typ.)
- Environment Temperature: -20°C~85°C

Applications

- Power Management for Computer Mother Board, Graphic Card
- LCD Monitor and LCD TV
- DVD Decode Board
- ADSL Modem
- Post Regulators For Switching Supplies

General Description

AMS1117-3.3V-JSM is a series of low dropout three-terminal regulators with a dropout of 13V at 800mA load current. AMS1117 features a very low standby current 2mA compared to 5mA of competitor.

Other than a fixed version, $V_{out} = 1.2V, 1.8V, 2.5V, 2.85V, 3.3V,$ and 5V, AMS1117 has an adjustable version, which can provide an output voltage from 1.25 to 12V with only two external resistors.

AMS1117 offers thermal shut down function, to assure the stability of chip and power system. And it uses trimming technique to guarantee output voltage accuracy within 2%. Other output voltage accuracy can be customized on demand, such as 1%.

AMS1117 is available in SOT-223, TO-252, SOT-89 power package.

Typical Application

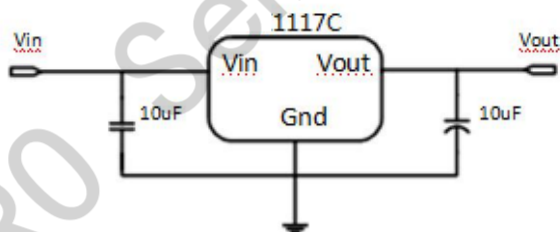

Application circuit of AMS1117 fixed version

Typical Electrical Characteristic

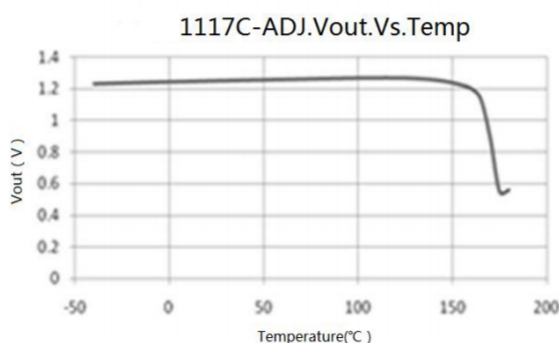

Selection Table

| Marking | Part No. | Output Voltage | Package |
|----------------|----------|----------------|-----------------------------|
| 1117 XXYYWW | XX=12 | 1.2V | SOT-223 TO-252 SOT-89 |
| | XX=18 | 1.8V | |
| | XX=28 | 2.85V | |
| | XX=25 | 2.5V | |
| | XX=33 | 3.3V | |
| | XX=50 | 5.0V | |
| | XX=AD | Adj | |

Ordering Information

| Marking | Designator | Description |
|----------------|------------|---------------------------|
| 1117 XXYYWW | 1117 | Product code |
| | XX | Output Voltage(1.2~12.0V) |
| | YYWW | DATE CODE |

Note: "XX" stands for output voltages. Other voltages can be specially customized

| Parameters | Description |
|------------------|------------------------------|
| Temperature&Rohs | C:-40~85℃ ,Pb Free Rohs Std. |
| Package type | L:SOT-223 O:TO-252 |
| Packing type: | TR:Tape&Reel (Standard) |
| Voltage accuracy | 2%(Customized) |

Block Diagram

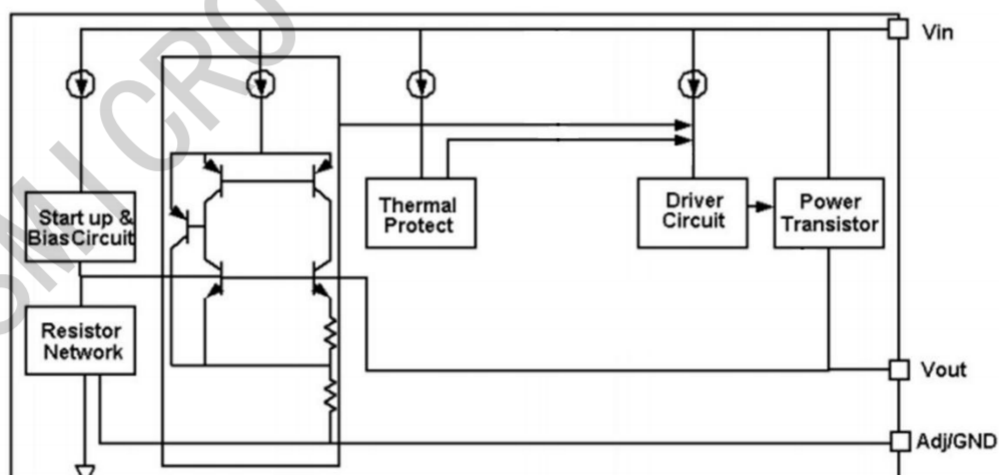

Pin Configuration

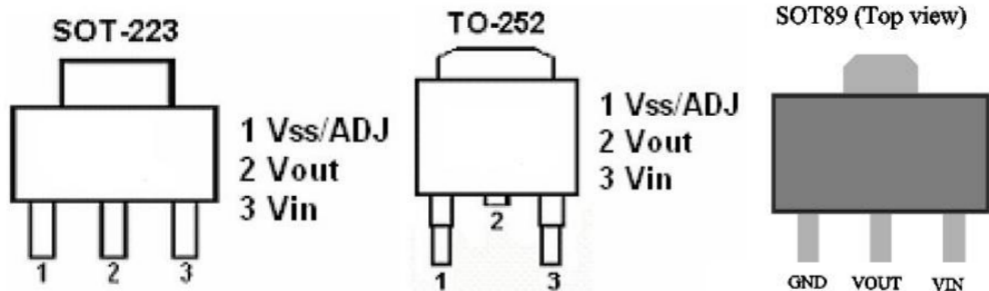

Absolute Maximum Ratings

| | | |
|---|-------|-------------|
| Max Input Voltage | | 30V |
| Max Operating Junction Temperature(T _j) | | 150°C |
| Ambient Temperature(T _a) | | -40°C~ 85°C |
| Storage Temperature(T _s) | | -40°C~150°C |
| Lead Temperature & Time | | 260°C 10S |

Caution: Exceed these limits to damage to the device. Exposure to absolute maximum rating conditions may affect device reliability.

Recommended Work Conditions

| | | |
|---|-------|-----------|
| Recommended maximum input voltage | | 15V |
| Recommended operating junction temperature(T _j) | | -20~125°C |

Thermal Information

| Parameter | Package | Rating | Unit |
|----------------------------|---------|--------|------|
| Package thermal resistance | SOT-223 | 20 | °C/W |
| | TO-252 | 12.5 | °C/W |
| | SOT89 | 200 | °C/W |

Electrical Characteristics
 $T_A=25^{\circ}\text{C}$, unless otherwise noted.

| Symbol | Parameter | Conditions | Min | Typ | Max | Unit |
|--------|-------------------|---|-------|------|-------|------|
| Vref | Reference voltage | AMS1117-Adj $10\text{mA} \leq I_{\text{out}} \leq 800\text{mA}$, $V_{\text{in}}=3.25\text{V}$ | 1.225 | 1.25 | 1.275 | V |
| Vout | Output voltage | AMS1117-1.2V $0 \leq I_{\text{out}} \leq 800\text{mA}$, $V_{\text{in}}=3.2\text{V}$ | 1.176 | 1.2 | 1.224 | V |
| | | AMS1117-1.8V $0 \leq I_{\text{out}} \leq 800\text{mA}$, $V_{\text{in}}=3.8\text{V}$ | 1.764 | 1.8 | 1.836 | V |
| | | AMS1117-2.5V $0 \leq I_{\text{out}} \leq 800\text{mA}$, $V_{\text{in}}=4.5\text{V}$ | 2.45 | 2.5 | 2.55 | V |
| | | AMS1117-2.85V $0 \leq I_{\text{out}} \leq 800\text{mA}$, $V_{\text{in}}=4.85\text{V}$ | 2.793 | 2.85 | 2.907 | V |
| | | AMS1117-3.3V $0 \leq I_{\text{out}} \leq 800\text{mA}$, $V_{\text{in}}=5.3\text{V}$ | 3.234 | 3.3 | 3.366 | V |
| | | AMS1117-5.0V $0 \leq I_{\text{out}} \leq 800\text{mA}$, $V_{\text{in}}=7.0\text{V}$ | 4.9 | 5 | 5.1 | V |

| | | | | | | |
|-------------------------|-----------------|---|--|------|-----|-----|
| ΔV_{out} | Line regulation | AMS1117-1.2V $I_{\text{out}}=10\text{mA}$, $2.7\text{V} \leq V_{\text{in}} \leq 10\text{V}$ | | 0.03 | 0.2 | %/V |
| | | AMS1117-ADJ $I_{\text{out}}=10\text{mA}$, $2.75\text{V} \leq V_{\text{in}} \leq 12\text{V}$ | | 0.03 | 0.2 | %/V |
| | | AMS1117-1.8V $I_{\text{out}}=10\text{mA}$, $3.3\text{V} \leq V_{\text{in}} \leq 12\text{V}$ | | 0.03 | 0.2 | %/V |
| | | AMS1117-2.5V $I_{\text{out}}=10\text{mA}$, $4.0\text{V} \leq V_{\text{in}} \leq 12\text{V}$ | | 0.03 | 0.2 | %/V |
| | | AMS1117-2.85V $I_{\text{out}}=10\text{mA}$, $4.35\text{V} \leq V_{\text{in}} \leq 12\text{V}$ | | 0.03 | 0.2 | %/V |
| | | AMS1117-3.3V $I_{\text{out}}=10\text{mA}$, $4.8\text{V} \leq V_{\text{in}} \leq 12\text{V}$ | | 0.03 | 0.2 | %/V |
| | | AMS1117-5.0V $I_{\text{out}}=10\text{mA}$, $6.5\text{V} \leq V_{\text{in}} \leq 12\text{V}$ | | 0.03 | 0.2 | %/V |

| | | | | | | |
|-------------------------|-----------------|---|--|---|----|----|
| ΔV_{out} | Load regulation | AMS1117-1.2V $V_{\text{in}}=2.7\text{V}$, $10\text{mA} \leq I_{\text{out}} \leq 800\text{mA}$ | | 2 | 8 | mV |
| | | AMS1117-ADJ $V_{\text{in}}=2.75\text{V}$, $10\text{mA} \leq I_{\text{out}} \leq 800\text{mA}$ | | 2 | 8 | mV |
| | | AMS1117-1.8V $V_{\text{in}}=3.3\text{V}$, $10\text{mA} \leq I_{\text{out}} \leq 800\text{mA}$ | | 3 | 12 | mV |
| | | AMS1117-2.5V $V_{\text{in}}=4.0\text{V}$, $10\text{mA} \leq I_{\text{out}} \leq 800\text{mA}$ | | 4 | 16 | mV |

| | | | | | |
|-----------------|-------------------------|--|------|-----|------|
| | | AMS1117-2.85V Vin =4.35V, 10mA≤Iout≤800mA | 5 | 20 | mV |
| | | AMS1117-3.3 Vin =4.8V, 10mA≤Iout≤800mA | 6 | 24 | mV |
| | | AMS1117-5.0 Vin =6.5V, 10mA≤Iout≤800mA | 9 | 36 | mV |
| Vdrop | Dropout voltage | Iout =100mA | 1.2 | 1.3 | V |
| | | Iout=800mA | 1.3 | 1.5 | V |
| Imin | Minimum load current | AMS1117-ADJ | 2 | 10 | mA |
| Iq | Quiescent Current | AMS1117-1.2V, Vin=10V | 2 | 5 | mA |
| | | AMS1117-1.8V, Vin=12V | 2 | 5 | mA |
| | | AMS1117-2.5V, Vin=12V | 2 | 5 | mA |
| | | AMS1117-2.85V, Vin=12V | 2 | 5 | mA |
| | | AMS1117-3.3V, Vin=12V | 2 | 5 | mA |
| | | AMS1117-5.0V, Vin=12V | 2 | 5 | mA |
| IAdj | Adjust pin current | AMS1117-ADJ Vin=5V, 10mA≤Iout≤800mA | 55 | 120 | uA |
| Ichange | Iadj change | AMS1117-ADJ Vin=5V, 10mA≤Iout≤800mA | 0.2 | 10 | uA |
| ΔV/ΔT | Temperature coefficient | | ±100 | | ppm |
| θ _{JC} | Thermal resistance | SOT-223 | 20 | | °C/W |
| | | TO-252 | 10 | | |

Note1: All test are conducted under ambient temperature 25°C and within a short period of time 20ms

Note2: Load current smaller than minimum load current of AMS1117-ADJ will lead to unstable or oscillation output.

Detailed Description

AMS1117 is a series of low dropout voltage, three terminal regulators. Its application circuit is very simple: the fixed version only needs two capacitors and the adjustable version only needs two resistors and two capacitors to work. It is composed of some modules including start-up circuit, bias circuit, bandgap, thermal shutdown, power transistors and its driver circuit and so on.

The thermal shut down modules can assure chip and its application system working safety when the junction temperature is larger than 140°C.

The bandgap module provides stable reference voltage, whose temperature coefficient is compensated by careful design considerations. The temperature coefficient is under 100 ppm/°C. And the accuracy of output voltage is guaranteed by trimming technique.

Typical Application

AMS1117 has an adjustable version and six fixed versions (1.2V, 1.8V, 2.5V, 2.85V, 3.3V and 5V)

Fixed Output Voltage Version

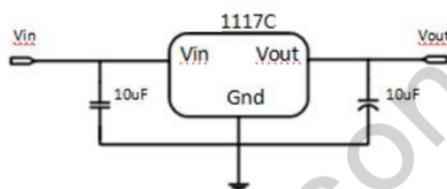

Application circuit of AMS1117 fixed version

- 1) Recommend using 10µF tan capacitor as bypass capacitor (C1) for all application circuit.
- 2) Recommend using 10µF tan capacitor to assure circuit stability.

Adjustable Output Voltage Version

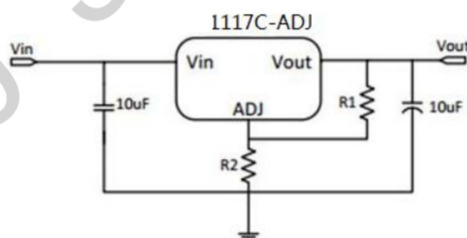

Application Circuit of AMS1117-ADJ

The output voltage of adjustable version follows the equation: $V_{out} = 1.25 \times (1 + R2/R1) + I_{Adj} \times R2$. We can ignore I_{Adj} because I_{Adj} (about 50µA) is much less than the current of $R1$ (about 2~10mA).

1) To meet the minimum load current (>10mA) requirement, $R1$ is recommended to be 125ohm or lower. As HS1117C-ADJ can keep itself stable at load current about 2mA, $R1$ is not allowed to be higher than 625ohm.

2) Using a bypass capacitor (C_{ADJ}) between the ADJ pin and ground can improve ripple rejection. This bypass capacitor prevents ripple from being amplified as the output voltage is increased. The impedance of C_{ADJ} should be less than $R1$ to prevent ripple from being amplified. As $R1$ is normally in the range of 100Ω~500Ω, the value of C_{ADJ} should satisfy this equation: $1/(2\pi \times f_{ripple} \times C_{ADJ}) < R1$.

Thermal Considerations

We have to take heat dissipation into great consideration when output current or differential voltage of input and output voltage is large. Because in such cases, the power dissipation consumed by AMS1117 is very large. AMS1117 series uses SOT-223 package type and its thermal resistance is about 20°C/W. And the copper area of application board can affect the total thermal resistance. If copper area is 5cm*5cm (two sides), the resistance is about 30°C/W. So the total thermal resistance is about 20°C/W + 30°C/W. We can decrease total thermal resistance by increasing copper area in application board. When there is no good heat dissipation copper area in PCB, the total thermal resistance will be as high as 120°C/W, then the power dissipation of AMS1117 could allow on itself is less than 1W. And furthermore, AMS1117 will work at junction temperature higher than 125°C under such condition and no lifetime is guaranteed.

Typical Performance Characteristics

T_A=25°C, unless otherwise noted.

Line regulation

1117C-ADJ Vout Vs. Vin

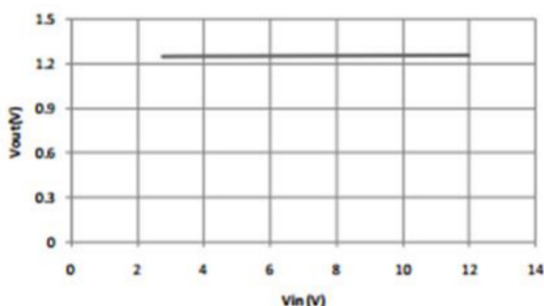

Load regulation

1117C-ADJ Vout Vs. Iout

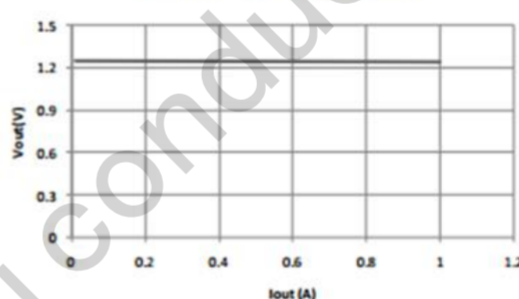

Dropout voltage

Dropout voltage

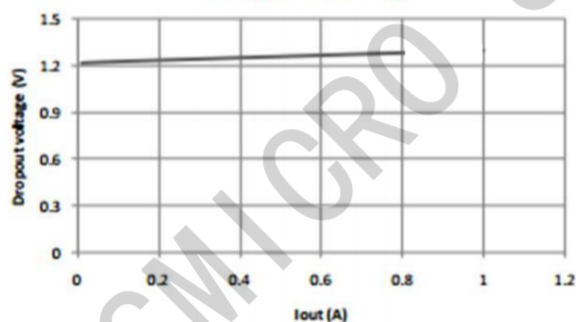

Thermal performance with OTP

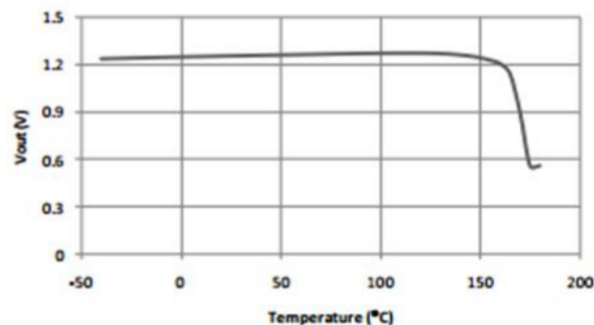

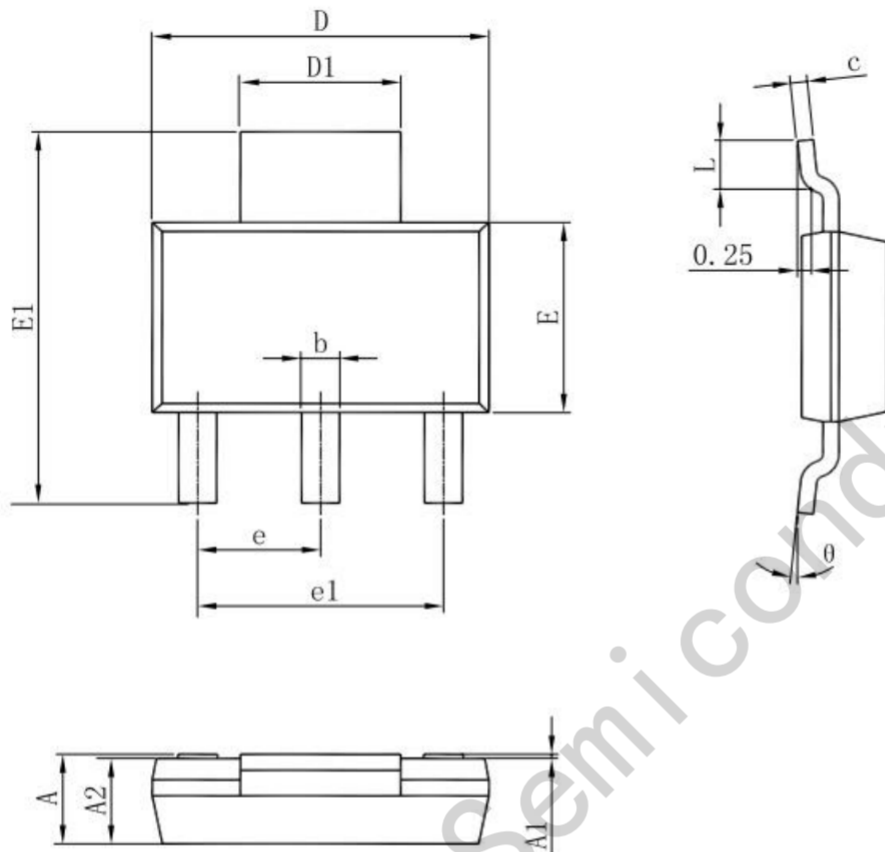
Package Information
SOT-223 PACKAGE OUTLINE DIMENSIONS

| Symbol | Dimensions In Millimeters | | Dimensions In Inches | |
|--------|---------------------------|-------|----------------------|-------|
| | Min | Max | Min | Max |
| A | 1.520 | 1.800 | 0.060 | 0.071 |
| A1 | 0.000 | 0.100 | 0.000 | 0.004 |
| A2 | 1.500 | 1.700 | 0.059 | 0.067 |
| b | 0.660 | 0.820 | 0.026 | 0.032 |
| c | 0.250 | 0.350 | 0.010 | 0.014 |
| D | 6.200 | 6.400 | 0.244 | 0.252 |
| D1 | 2.900 | 3.100 | 0.114 | 0.122 |
| E | 3.300 | 3.700 | 0.130 | 0.146 |
| E1 | 6.830 | 7.070 | 0.269 | 0.278 |
| e | 2.300(BSC) | | 0.091(BSC) | |
| e1 | 4.500 | 4.700 | 0.177 | 0.185 |
| L | 0.900 | 1.150 | 0.035 | 0.045 |
| θ | 0° | 10° | 0° | 10° |

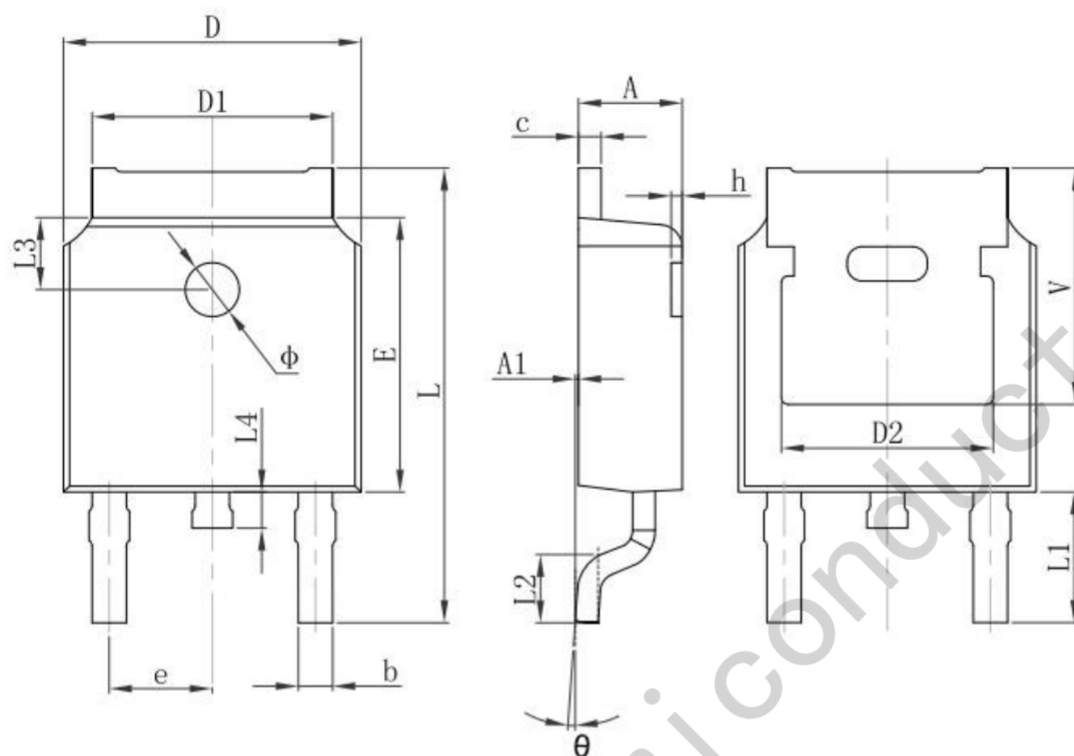
TO-252-2L PACKAGE OUTLINE DIMENSIONS

| Symbol | Dimensions In Millimeters | | Dimensions In Inches | |
|--------|---------------------------|--------|----------------------|-------|
| | Min. | Max. | Min. | Max. |
| A | 2.200 | 2.400 | 0.087 | 0.094 |
| A1 | 0.000 | 0.127 | 0.000 | 0.005 |
| b | 0.660 | 0.860 | 0.026 | 0.034 |
| c | 0.460 | 0.580 | 0.018 | 0.023 |
| D | 6.500 | 6.700 | 0.256 | 0.264 |
| D1 | 5.100 | 5.460 | 0.201 | 0.215 |
| D2 | 4.830 REF. | | 0.190 REF. | |
| E | 6.000 | 6.200 | 0.236 | 0.244 |
| e | 2.186 | 2.386 | 0.086 | 0.094 |
| L | 9.800 | 10.400 | 0.386 | 0.409 |
| L1 | 2.900 REF. | | 0.114 REF. | |
| L2 | 1.400 | 1.700 | 0.055 | 0.067 |
| L3 | 1.600 REF. | | 0.063 REF. | |
| L4 | 0.600 | 1.000 | 0.024 | 0.039 |
| Φ | 1.100 | 1.300 | 0.043 | 0.051 |
| θ | 0° | 8° | 0° | 8° |
| h | 0.000 | 0.300 | 0.000 | 0.012 |
| V | 5.350 REF. | | 0.211 REF. | |

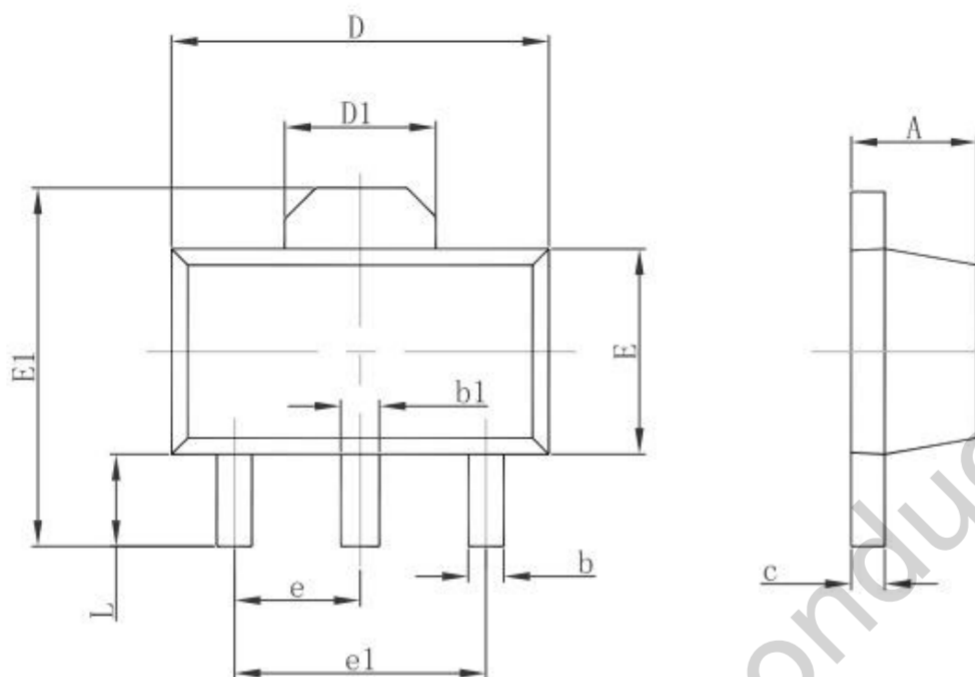
3-pin SOT89 Outline Dimensions

| Symbol | Dimensions In Millimeters | | Dimensions In Inches | |
|--------|---------------------------|-------|----------------------|-------|
| | Min. | Max. | Min. | Max. |
| A | 1.400 | 1.600 | 0.055 | 0.063 |
| b | 0.320 | 0.520 | 0.013 | 0.020 |
| b1 | 0.400 | 0.580 | 0.016 | 0.023 |
| c | 0.350 | 0.440 | 0.014 | 0.017 |
| D | 4.400 | 4.600 | 0.173 | 0.181 |
| D1 | 1.550 REF. | | 0.061 REF. | |
| E | 2.300 | 2.600 | 0.091 | 0.102 |
| E1 | 3.940 | 4.250 | 0.155 | 0.167 |
| e | 1.500 TYP. | | 0.060 TYP. | |
| e1 | 3.000 TYP. | | 0.118 TYP. | |
| L | 0.900 | 1.200 | 0.035 | 0.047 |

X-ON Electronics

Largest Supplier of Electrical and Electronic Components

Click to view similar products for [LDO Voltage Regulators](#) category:

Click to view products by [JSMSEMI](#) manufacturer:

Other Similar products are found below :

[AP7363-SP-13](#) [NCV8664CST33T3G](#) [L79M05TL-E](#) [AP7362-HA-7](#) [PT7M8202B12TA5EX](#) [TCR3DF185,LM\(CT](#) [TLF4949EJ](#)
[NCP4687DH15T1G](#) [NCV8703MX30TCG](#) [LP2951CN](#) [NCV4269CPD50R2G](#) [AP7315-25W5-7](#) [NCV47411PAAJR2G](#) [AP2111H-1.2TRG1](#)
[ZLDO1117QK50TC](#) [AZ1117ID-ADJTRG1](#) [NCV4263-2CPD50R2G](#) [NCP114BMX075TCG](#) [MC33269T-3.5G](#) [TLE4471GXT](#) [AP7315-33SA-](#)
[7](#) [NCV4266-2CST33T3G](#) [NCP715SQ15T2G](#) [NCV8623MN-50R2G](#) [NCV563SQ18T1G](#) [NCV8664CDT33RKG](#) [NCV4299CD250R2G](#)
[NCP715MX30TBG](#) [NCV8702MX25TCG](#) [L974113TR](#) [TLE7270-2E](#) [NCV562SQ25T1G](#) [AP2213D-3.3TRG1](#) [AP2202K-2.6TRE1](#)
[NCV8170BMX300TCG](#) [NCV8152MX300180TCG](#) [NCP700CMT45TBG](#) [AP7315-33W5-7](#) [LD56100DPU28R](#) [NCP154MX180300TAG](#)
[AP2210K-3.0TRE1](#) [AP2113AMTR-G1](#) [NJW4104U2-33A-TE1](#) [MP2013AGG-5-P](#) [NCV8775CDT50RKG](#) [NJM2878F3-45-TE1](#) [S-](#)
[19214B00A-V5T2U7](#) [S-19214B50A-V5T2U7](#) [S-19213B50A-V5T2U7](#) [S-19214BC0A-E8T1U7*1](#)