

■ DESCRIPTION

LM224 consist of four independent, high-gain, frequency-compensated operational amplifiers which are designed to operate from a single power supply over a wide range of voltage. Operation from split supplies is also possible so long as the difference between the two supplies is 3V ~ 30V. The low supply current drain is independent of the magnitude of the supply voltage.

The device can easily be implemented in single supply voltage system, including transducer amplifiers, DC gain blocks, and all of conventional OP Amp circuits.

■ FEATURES

- * Wide Supply Voltage Range.(Single Supply: 3~30V)
- * Low Supply Current Drain Independent of Supply Voltage: 0.8 mA Typ
- * Large DC voltage gain: 100dB
- * Input Common-Mode Voltage Range Includes Ground.
- * Low Input Bias and Offset Parameters
- * Differential Input Voltage Range Equal to Maximum Rated Supply Voltage: 32V
- * Open-Loop Differential Voltage Amplification: 100 V/mV Typ
- * Internal Frequency Compensation for Unity Gain

■ PIN CONFIGURATION

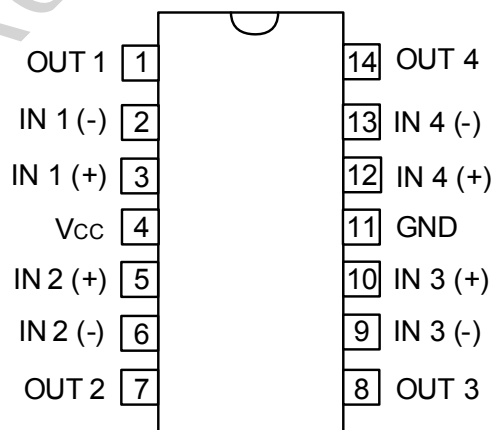

■ ABSOLUTE MAXIMUM RATINGS

PARAMETER	SYMBOL	RATINGS	UNIT
Supply Voltage (Note 1)	V_{CC}	32	V
Differential Input voltage (Note 2)	$V_{I(DIFF)}$	± 32	V
Input Voltage	V_{IN}	-0.3 ~ +32	V
Output Short Circuit (one amplifier) to Ground ($T_a \leq 25$, $V_{CC} \leq 15V$) (Note 3)		Continuous	
Power Dissipation($T_a=25^\circ C$)	P_D	900	mW
Operation Temperature (Note 4)	T_{OPR}	-25 ~ +85	
Storage Temperature	T_{STG}	-40 ~ +150	

NOTES: 1.All voltage values(except differential voltages and V_{CC} specified for the measurement of $I_{IN(OS)}$) are with respect to the network GND.

2. Differential voltages are at IN+ with respect to IN-.

3. Short circuits from outputs to V_{CC} can cause excessive heating and eventual destruction.

4.The device is guaranteed to meet performance specification within 0 ~70 operating temperature range and assured by design from -25 ~+85 .

 ■ ELECTRICAL CHARACTERISTICS ($V_{CC}=5V$, unless otherwise specified, $V_{CC}=30V$ for testing only.)

PARAMETER	SYMBOL	T_a ()	TEST CONDITIONS	MIN	TYP	MAX	UNIT
Input Offset Voltage	$V_{IN(OS)}$	25	$V_{CC}=5V$ to 30V, $V_{IC}=V_{ICR(min)}$, $V_{OUT}=1.4V$		3	5	mV
		-25~85				7	
Input Offset Current	$I_{IN(OS)}$	25	$V_{OUT}=1.4V$		2	30	nA
		-25~85				100	
Input Bias Current	I_B	25	$V_{OUT}=1.4V$		-20	-150	nA
		-25~85				-300	
Input Common-mode Voltage Range	V_{ICR}	25	$V_{CC}=5V$ to 30V	0~($V_{CC}-1.5$)			V
		-25~85		0~($V_{CC}-2$)			
Output Voltage Level	High	V_{OH}	25	$R_L=2k\Omega$	$V_{CC}-1.5$		V
			-25~85	$V_{CC}=30V$, $R_L=2k\Omega$	26		
				$V_{CC}=30V$, $R_L \geq 10k\Omega$	27	28	
Low	V_{OL}	-25~85	$R_L \leq 10k\Omega$		5	20	mV
Large Signal Current Gain	G_V	25	$V_{CC}=15V$, $V_{OUT}=1V \sim 11V$ $R_L \geq 2k\Omega$	50	100		V/mV
		-25~85		25			
Common-mode Rejection Ratio	CMRR	25	$V_{IC}=V_{ICR(min)}$	70	80		dB
Supply Voltage Rejection Ratio ($\Delta V_{CC}/\Delta V_{IO}$)	SVR	25		65	100		dB
Crosstalk Attenuation	V_{O1}/V_{O2}	25	$f=1kHz \sim 20kHz$		120		dB
Output Current	I_{OUT}	25	$V_{CC}=15V$, $V_{ID}=1V$, $V_{OUT}=0$	-20	-30	-60	mA
		-25~85		-10			
		25	$V_{CC}=15V$, $V_{ID}=-1V$, $V_{OUT}=15V$	10	20		
		-25~85		5			
25	$V_{ID}=-1V$, $V_{OUT}=200mV$	12	30		μA		
Short-circuit Output Current	I_{OS}	25	$V_{CC}=5V$, $V_{OUT}=0$, GND at -5V		± 40	± 60	mA
Supply Current (four amplifiers)	I_{CC}	-25~85	$V_{OUT}=2.5V$, $R_L=$		0.7	1.2	mA
			$V_{CC}=30V$, $V_{OUT}=0.5V_{CC}$, $R_L=$		1.4	3	

Note: All characteristics are measured under open-loop conditions with zero common-mode input voltage.

■ THERMAL DATA

PARAMETER	SYMBOL	RATINGS	UNIT
Thermal Resistance Junction-Ambient	SOP-14	86	/W
	DIP-14	80	
	TSSOP-14	113	

■ SCHEMATIC DIAGRAM(One Section Only)

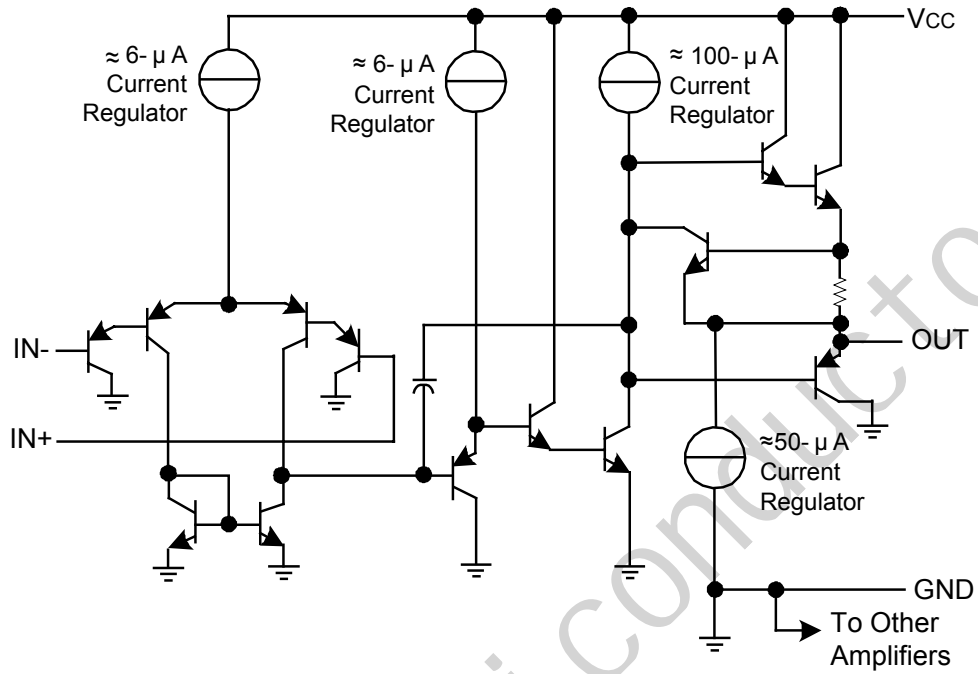

■ Package Dimensions

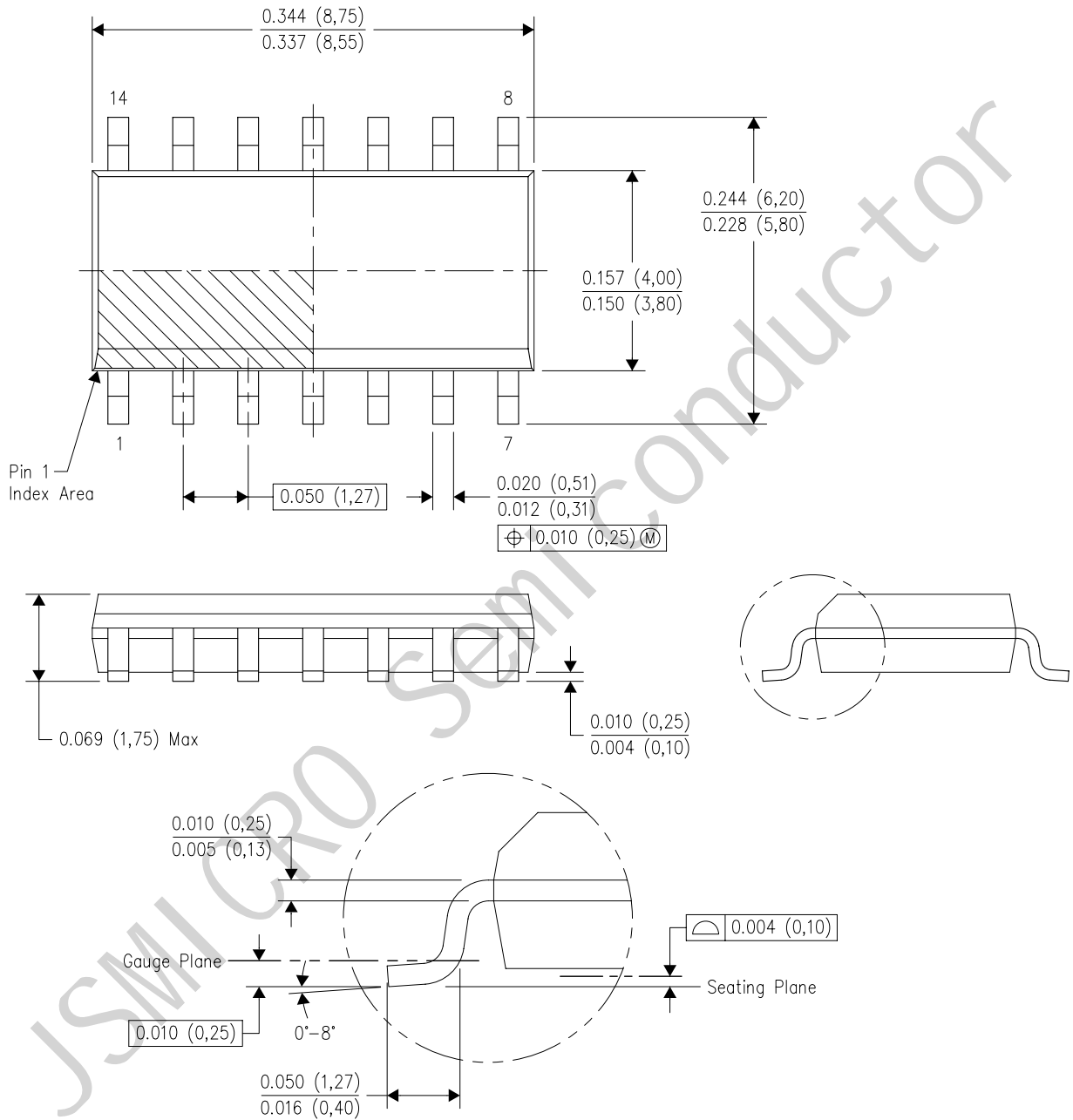

X-ON Electronics

Largest Supplier of Electrical and Electronic Components

Click to view similar products for [Operational Amplifiers - Op Amps](#) category:

Click to view products by [JSMSEMI](#) manufacturer:

Other Similar products are found below :

[430227FB](#) [UPC451G2-A](#) [UPC824G2-A](#) [LT1678IS8](#) [UPC258G2-A](#) [NCV33202DMR2G](#) [NJM324E](#) [M38510/13101BPA](#) [NTE925](#)
[AZV358MTR-G1](#) [AP4310AUMTR-AG1](#) [AZV358MMTR-G1](#) [SCY33178DR2G](#) [NCV5652MUTWG](#) [NCV20034DR2G](#) [NTE778S](#) [NTE871](#)
[NTE937](#) [MCP6V16UT-E/OT](#) [SCY6358ADR2G](#) [UPC4570G2-E1-A](#) [NCS20282FCTTAG](#) [UPC834G2-E1-A](#) [UPC1458G2-E2-A](#) [UPC813G2-](#)
[E2-A](#) [UPC458G2-E1-A](#) [UPC824G2-E2-A](#) [UPC4574G2-E2-A](#) [UPC4558G2-E2-A](#) [UPC4560G2-E1-A](#) [UPC258G2-E1-A](#) [UPC4742GR-9LG-](#)
[E1-A](#) [UPC4742G2-E1-A](#) [UPC832G2-E2-A](#) [UPC842G2-E1-A](#) [UPC802G2-E1-A](#) [UPC4741G2-E2-A](#) [UPC4572G2-E2-A](#) [UPC844GR-9LG-](#)
[E2-A](#) [UPC259G2-E1-A](#) [UPC4741G2-E1-A](#) [UPC4558G2-E1-A](#) [UPC1251GR-9LG-E1-A](#) [UPC4744G2-E1-A](#) [UPC4092G2-E1-A](#)
[UPC4574G2-E1-A](#) [UPC4062G2-E2-A](#) [UPC451G2-E2-A](#) [UPC832G2-E1-A](#) [UPC844GR-9LG-E1-A](#)