

## FEATURES

- Operates from a Single 3.3V Supply
- Interoperable with +5.0V Logic
- -7V to 12V Common-Mode Input Voltage Range
- Three-State Outputs
- Driver/ Receiver Enable
- Half-Duplex Communication
- Allows up to 32 Transceivers on the Bus
- Data Rate up to 12 Mbps
- Current-Limiting and Thermal Shutdown for Driver Overload Protection
- ESD Specifications
  - ±15kV IEC61000-4-2 Air Discharge
  - ±8kV Human Body Model

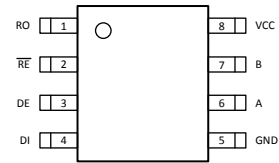

SOP-8

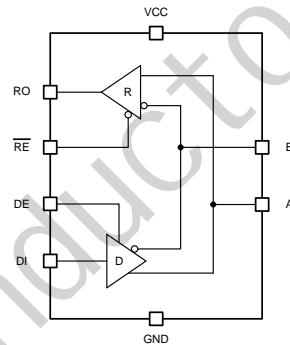

## DESCRIPTION

The MAX3485 is a low-power half-duplex transceiver that meets the specifications of RS-485 and RS-422. IC contains one driver and one receiver. The driver slew rates is not limited, allowing them to transmit up to 12Mbps. These transceivers draw between 120 $\mu$ A and 500 $\mu$ A of supply current when unloaded or fully loaded with disabled drivers. All parts operate from a single 3.3V supply. Drivers are short-circuit current limited and are protected against excessive power dissipation by thermal shutdown circuitry that places the driver outputs into a high-impedance state. The receiver input has a fail-safe feature that guarantees a logic-high output if the input is open circuit. The ESD tolerance is more than  $\pm 8$ kV for both Human Body Model and  $\pm 15$ kV for IEC61000-4-2 Air Discharge Method on this device.

## APPLICATIONS

- Low Power RS-485 Systems
- Telecommunications
- Packet Switching
- Industrial-Control Local Area Networks
- Data Concentration
- Data Multiplexers
- Integrated Services Digital Network (ISDN)

**ABSOLUTE MAXIMUM RATINGS** (Note 1)

CHARACTERISTIC	SYMBOL	MIN.	MAX.	UNIT
Supply Voltage	$V_{CC}$	-0.3	6.0	V
Control Input Voltage	$V_{RE}, V_{DE}$	-0.3	6.0	V
Driver Input Voltage	$V_{DI}$	-0.3	6.0	V
Driver Output Voltage	$V_A, V_B$	-15	15	V
Receiver Input Voltage	$V_A, V_B$	-15	15	V
Receiver Output Voltage	$V_{RO}$	-0.3	$V_{CC} + 0.3$	V
Junction Temperature Range	$T_J$	-40	125	°C
Storage Temperature Range	$T_{STG}$	-65	150	°C

Note 1. Stresses beyond those listed under *Absolute Maximum Ratings* may cause permanent damage to the device. These are stress ratings only and functional operation of the device at these or any other conditions beyond those indicated under *Recommended Operating Conditions* is not implied. Exposure to absolute-maximum-rated conditions for extended periods may affect device reliability.

**RECOMMENDED OPERATING CONDITIONS** (Note 2)

CHARACTERISTIC	SYMBOL	MIN.	MAX.	UNIT
Supply Voltage	$V_{CC}$	0	$3.3 \pm 5\%$	V
Ambient Temperature Range	$T_A$	-40	85	°C

Note 2. The device is not guaranteed to function outside its operating ratings.

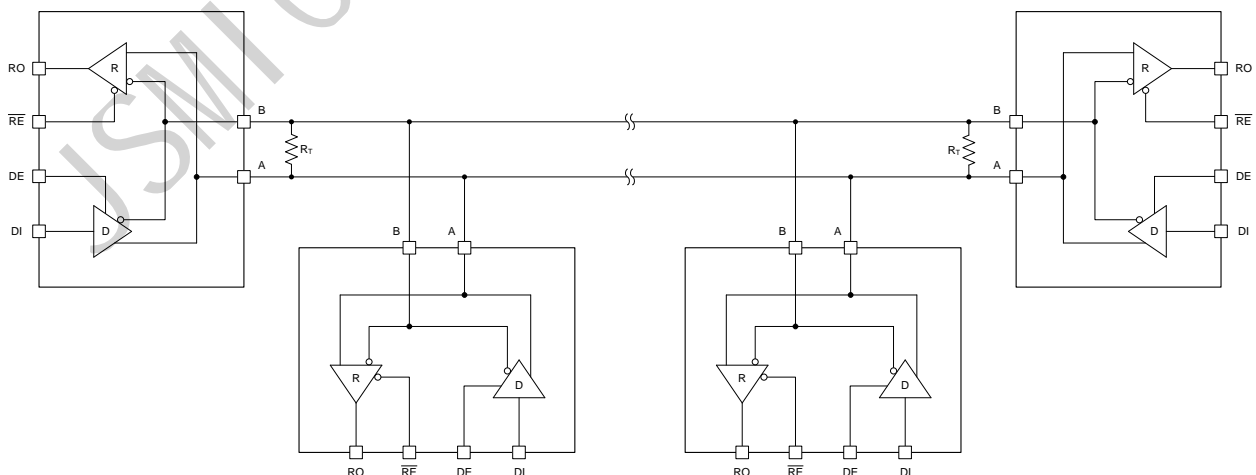
**TYPICAL APPLICATION**

< Typical RS-485 Network with Half-Duplex Transceivers >

## PIN CONFIGURATION

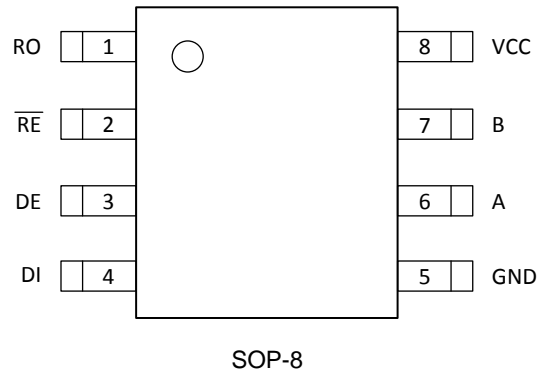

## PIN DESCRIPTION

Pin No.	Pin Name	Pin Function
1	RO	Receiver Output
2	$\overline{\text{RE}}$	Receiver Output Enable. Active Low
3	DE	Driver Output Enable. Active High
4	DI	Driver Input
5	GND	Ground
6	A	Non-Inverting Driver Output/ Non-Inverting Receiver Input
7	B	Inverting Driver Output/ Inverting Receiver Input
8	VCC	Power Supply

## DC ELECTRICAL CHARACTERISTICS

$V_{CC} = 3.3V$ ,  $T_A = 25^\circ C$ , unless otherwise noted.

PARAMETER	SYMBOL	TEST CONDITIONS	MIN	TYP	MAX	UNIT	
Differential Output Voltage	$V_{OD}$	Unloaded, $R_L = \infty$ , Figure 1	GND	-	$V_{CC}$	V	
		With Load, $R_L = 50\Omega$ (RS-422), Figure 1	1	-	$V_{CC}$		
		With Load, $R_L = 27\Omega$ (RS-485), Figure 1	0.6	-	$V_{CC}$		
Change in Magnitude of Driver Differential Output Voltage for Complimentary States (NOTE 3)	$\Delta V_{OD}$	$R_L = 27\Omega$ or $R_L = 50\Omega$ , Figure 1	-	-	0.2	V	
Driver Common- Mode Output Voltage	$V_{OC}$	$R_L = 27\Omega$ or $R_L = 50\Omega$ , Figure 1	-	-	3.0	V	
Input High Voltage	$V_{IH}$	DE, DI, $\overline{RE}$	2.0	-	-	V	
Input Low Voltage	$V_{IL}$	DE, DI, $\overline{RE}$	-	-	0.6	V	
Logic Input Current	$I_{IN1}$	DE, DI, $\overline{RE}$	-	-	$\pm 10$	$\mu A$	
Driver Short-Circuit Output Current	$I_{OSD}$	$V_{OUT} = \text{High or Low, } -7V \leq V_{OUT} \leq 12V$	-	-	$\pm 250$	mA	
Receiver Differential Input Threshold	$V_{TH}$	$-7V \leq V_{CM} \leq 12V$	-0.2	-	0.2	V	
Receiver Input Hysteresis	$\Delta V_{TH}$	$V_{CM} = 0V$	-	20	-	mV	
Receiver Output High Voltage	$V_{OH}$	$I_{OUT} = -1.5mA$ , $V_{ID} = 200mV$ , Figure 2	$V_{CC} - 0.4$	-	-	V	
Receiver Output Low Voltage	$V_{OL}$	$I_{OUT} = 2.5mA$ , $V_{ID} = 200mV$ , Figure 2	-	-	0.4	V	
Three-State (High Impedance) Output Current at Receiver	$I_{OZR}$	$0 \leq V_{OUT} \leq V_{CC}$ , $\overline{RE} = V_{CC}$	-	-	$\pm 1.0$	$\mu A$	
Receiver Input Resistance	$R_{IN}$	$-7V \leq V_{CM} \leq 12V$	12	15	-	k $\Omega$	
Receiver Input Current (A, B)	$I_{IN2}$	DE = 0V, $V_{CC} = 0V$ or 3.5V	$V_{IN} = 12V$	-	-	1.0	mA
			$V_{IN} = -7V$	-	-	-0.8	mA
Receiver Short Circuit Output Current	$I_{OSR}$	$0V \leq V_{OUTR} \leq V_{CC}$	7	-	60	mA	
Supply Current	$I_{CC}$	No Load, DI = 0V or $V_{CC}$	DE = $V_{CC}$ , $\overline{RE} = 0V$ or $V_{CC}$	-	425	2000	$\mu A$
			DE = 0V, $\overline{RE} = 0V$	-	300	1500	

Note 3.  $\Delta V_{OD}$  and  $\Delta V_{OC}$  are the changes in  $V_{OD}$  and  $V_{OC}$ , respectively, when the DI input changes state.

## AC ELECTRICAL CHARACTERISTICS

$V_{CC} = 3.3V$ ,  $T_A = 25^\circ C$ , unless otherwise noted.

PARAMETER	SYMBOL	TEST CONDITIONS	MIN	TYP	MAX	UNIT
Maximum Data Rate		$DE = \overline{RE} = V_{CC}$ or $0V$	10	12	15	Mbps
Driver Differential Output Transition Time	$t_{TD}$	Figure 3	-	5	20	ns
Driver Input to Output Propagation Delay, Low-to-High Level	$t_{PLH}$	Figure 4	-	17	60	ns
Driver Input to Output Propagation Delay, High-to-Low Level	$t_{PHL}$	Figure 4	-	17	60	ns
Driver Propagation Delay Skew	$t_{SKEW}$	Figure 4, $ t_{PLH} - t_{PHL} $	-	2	10	ns
Driver Output Enable Time to High	$t_{PZH}$	Figure 5	-	35	120	ns
Driver Output Enable Time to Low	$t_{PZL}$	Figure 6	-	30	120	ns
Driver Output Disable Time from High	$t_{PHZ}$	Figure 5	-	20	120	ns
Driver Output Disable Time from Low	$t_{PLZ}$	Figure 6	-	20	120	ns
Receiver Input to Output Propagation Delay, Low-to-High Level	$t_{RPLH}$	Figure 7	-	40	100	ns
Receiver Input to Output Propagation Delay, High-to-Low Level	$t_{RPHL}$	Figure 7	-	35	100	ns
Differential Receiver Propagation Delay Skew	$t_{RSKEW}$	Figure 7, $ t_{RPLH} - t_{RPHL} $	-	4	-	ns
Receiver Output Enable Time to Low	$t_{PRZL}$	Figure 8	-	10	60	ns
Receiver Output Enable Time to High	$t_{PRZH}$	Figure 8	-	10	60	ns
Receiver Output Disable Time from Low	$t_{PRLZ}$	Figure 8	-	10	60	ns
Receiver Output Disable Time from High	$t_{PRHZ}$	Figure 8	-	10	60	ns

## FUNCTION TABLE

Transmitting				
Inputs			Outputs	
$\overline{RE}$	DE	DI	B	A
X	1	1	0	1
X	1	0	1	0
0	0	X	Z	Z
1	0	X	Z	Z

Receiving			
Inputs			Output
$\overline{RE}$	DE	A - B	RO
0	0	$\geq +0.2V$	1
0	0	$\leq -0.2V$	0
0	0	Inputs Open	1
1	0	X	Z

X: Don't Care

Z: High Impedance

**PARAMETER MEASUREMENT INFORMATION**

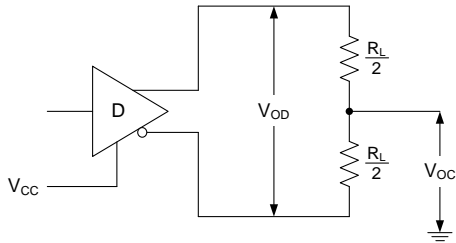

Fig. 1. Driver  $V_{OD}$  and  $V_{OC}$

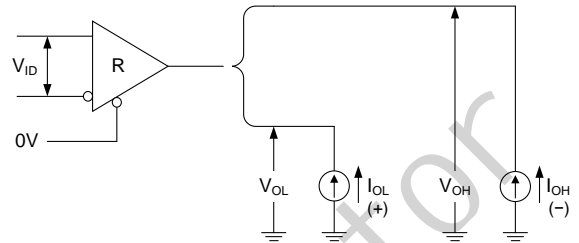

Fig. 2. Receiver  $V_{OH}$  and  $V_{OL}$

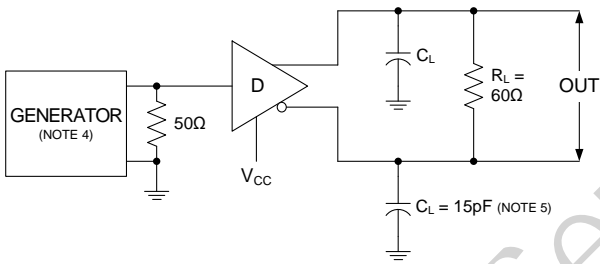

Fig. 3. Driver Differential Output Delay and Transition Times

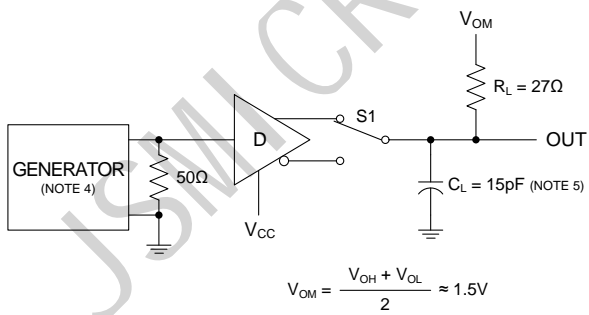
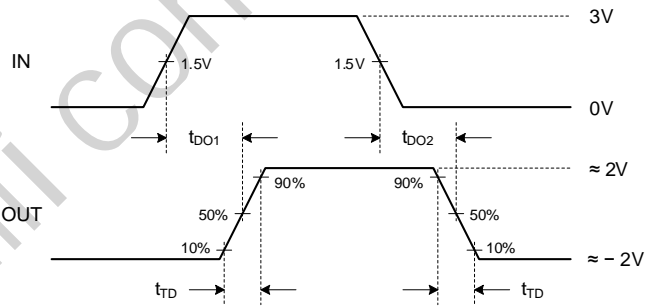
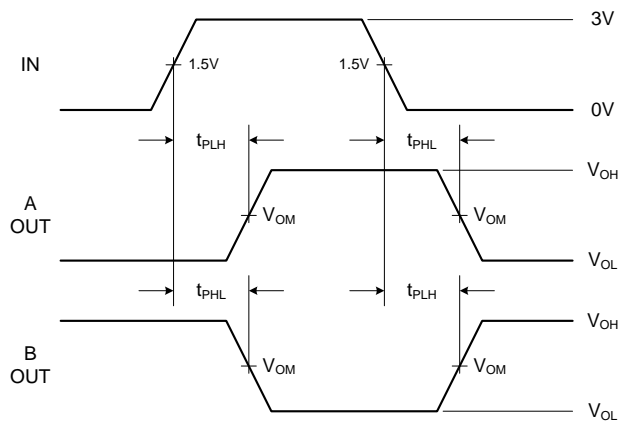

Fig. 4. Driver Propagation Delay



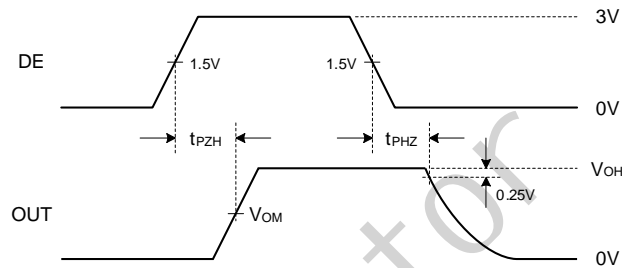
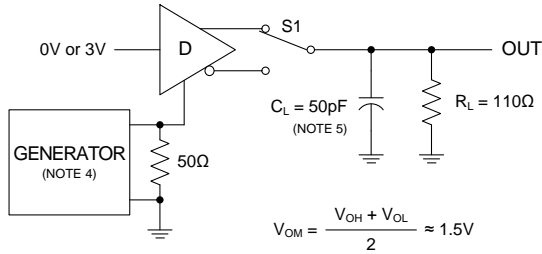

Fig. 5. Driver Enable and Disable Times, Output High

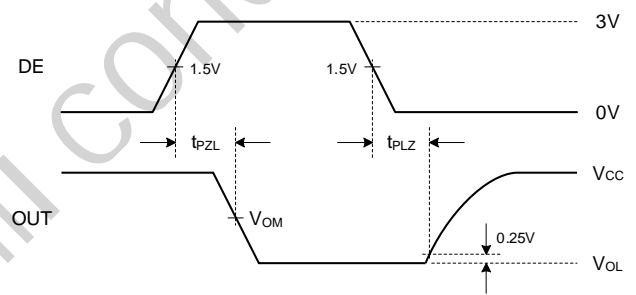
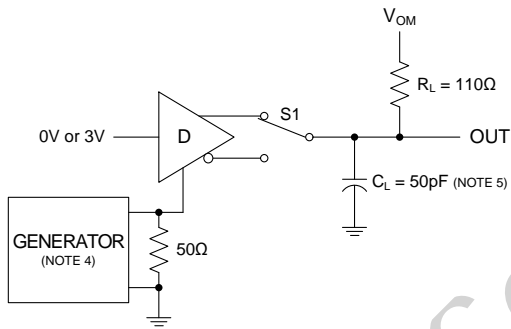

Fig. 6. Driver Enable and Disable Times, Output Low

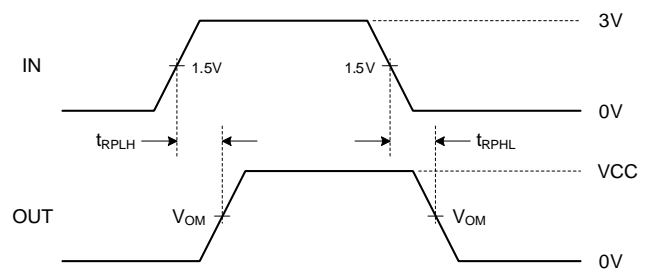
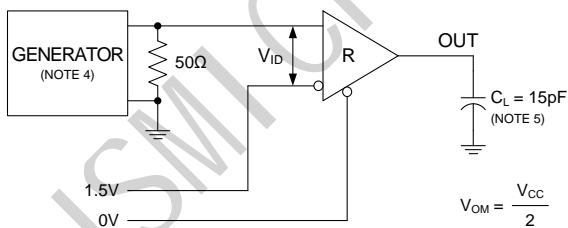

Fig. 7. Receiver Propagation Delay

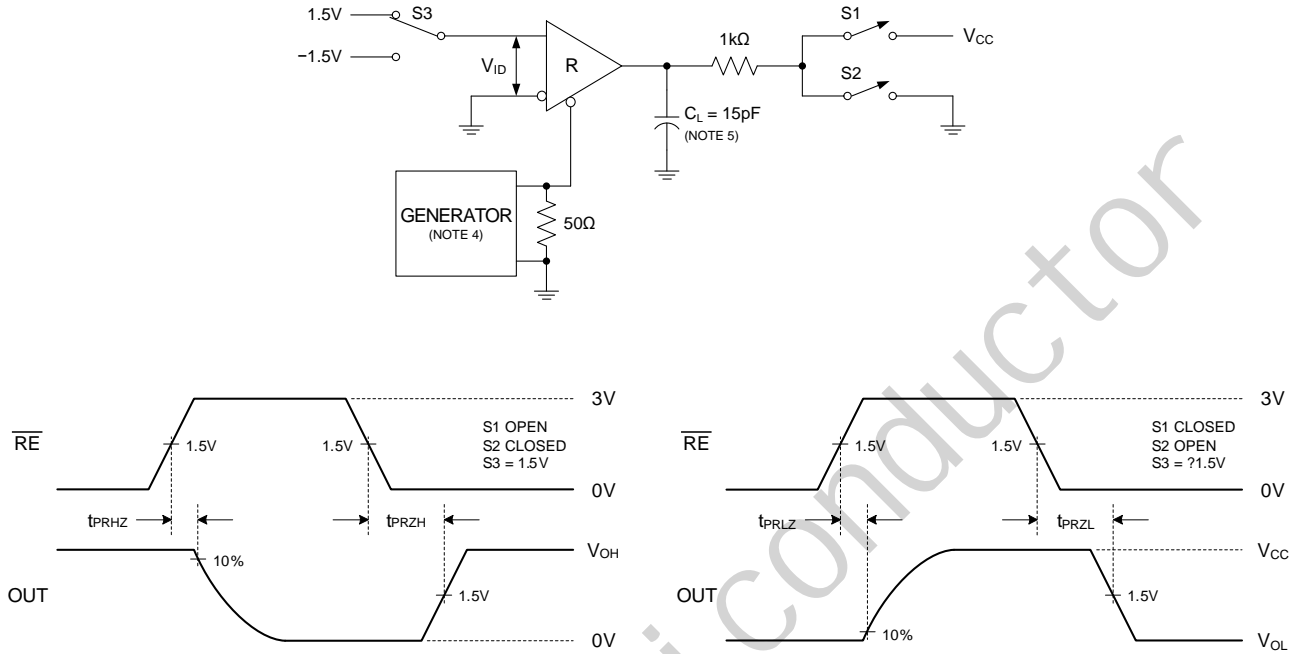

Fig. 8. Receiver Enable and Disable Times

Note 4. The input pulse is supplied by a generator with the following characteristics: PRR = 250kHz, 50% duty cycle,  $t_r \leq 6.0\text{ns}$ ,  $Z_o = 50\Omega$ .

Note 5.  $C_L$  includes probe and stray capacitance.



## APPLICATION INFORMATION

### Functional Description

The MAX3485 is 3.3V low power half-duplex differential transceiver that meets the requirements of RS-485 and RS-422. The RS-485 Standard is ideal for multi-drop applications and for long-distance interfaces. RS-485 allows up to 32 drivers and 32 receivers to be connected to a data bus, making it an ideal choice for multi-drop applications. Since the cabling can be as long as 4,000 feet, RS-485 transceivers are equipped with a wide common mode range of -7V to 12V to accommodate ground potential differences. Because RS-485 is a differential interface, data is virtually immune to noise in the transmission line.

### Output Enable

The receiver output RO is enabled when  $\overline{RE}$  is low. RO is high impedance when  $\overline{RE}$  is high. The driver outputs are enabled by bringing DE high. They are high impedance when DE is low. If the driver outputs are enabled, the parts function as line drivers. While they are high impedance, they function as line receivers if  $\overline{RE}$  is low.

### Driver

The driver outputs of the MAX3485 are differential outputs meeting the RS-485 and RS-422 standards. The typical voltage output swing with no load will be 0 Volts to 3.3 Volts. With worst case loading of 54 $\Omega$  across the differential outputs, the driver can maintain greater than 1.5V levels. The driver of the MAX3485 has an enable control line which is active high. A logic high on DE (pin 3) will enable the differential driver outputs. A logic low on DE (pin 3) will tri-state the driver outputs. The transmitter of the MAX3485 will operate up to 12Mbps.

### Receiver

The MAX3485 receiver has differential inputs with an input sensitivity as low as  $\pm 200\text{mV}$ . Input impedance of the receiver is typically 15k $\Omega$  (12k $\Omega$  minimum). A wide common mode range of -7V to +12V allows for large ground potential differences between systems. The receiver of the MAX3485 has a tri-state enable control pin. A logic low on  $\overline{RE}$  (pin 2) will enable the receiver, a logic high on  $\overline{RE}$  (pin 2) will disable the receiver. The receiver for the MAX3485 will operate up to 12Mbps. The receiver is equipped with the fail-safe feature. Fail-safe feature guarantees that the receiver output will be in a high state when the input is left unconnected.

## REVISION NOTICE

The description in this datasheet is subject to change without any notice to describe its electrical characteristics properly.

## X-ON Electronics

Largest Supplier of Electrical and Electronic Components

*Click to view similar products for [RS-422/RS-485 Interface IC category](#):*

*Click to view products by [JSMSEMI manufacturer](#):*

Other Similar products are found below :

[SP3494CN-L/TR](#) [ISL4486IBZ-T](#) [ISL4491EIB](#) [ISL4491EIBZ-T](#) [ISL81483IB](#) [ISL83086EIB](#) [ISL83088EIB](#) [ISL83488IB](#) [ISL8483EIB](#)  
[ISL8487EIB](#) [ISL8489EIB](#) [ISL8491IP](#) [ADM489AN](#) [CA-IF4820HM](#) [CS48505M](#) [CS485S](#) [CS817x22HS](#) [MAX485ESA-MS](#) [MAX3085](#)  
[ADM3485EARZ](#) [SP3485EEN](#) [TP3485ES8](#) [MAX3485ESA](#) [ST3485EBDR](#) [ADM485ARZ](#) [CA-IF4820HD](#) [CA-IF1042S-Q1](#) [CA-IF1021D-Q1](#)  
[CS48520D](#) [SN65HVD78EIMM/TR](#) [HGX3085ECMM/TR](#) [SP3085EIMM/TR](#) [HGX3085EIMM/TR](#) [SN65HVD72EIMM/TR](#) [HGX485EIN](#)  
[RS1905XK](#) [SIT1044QTK](#) [THVD1420DR](#) [MAX3490EESA+T](#) [UM3483EESA](#) [HD588L](#) [HD568N](#) [HD688ADR](#) [CA-IS3080WX](#) [CA-](#)  
[IS3086WX](#) [CS817x20HS](#) [CA-IF1044S-Q1](#) [CA-IF4820FS](#) [CA-IF4850HS](#) [GM3490E](#)