

DESCRIPTION

The family is monolithic fixed voltage regulator integrated circuit. They are suitable for applications that required supply current up to 1.5 A.

FEATURES

- * Peak output current up to 1.5A.
- * Fixed output voltage of 5V, 6V, 7V, 8V, 9V, 10V, 12V, 15V and 18V available.
- * Thermal overload shutdown protection.
- * Short circuit current limiting.
- * Output transistor SOA protection.

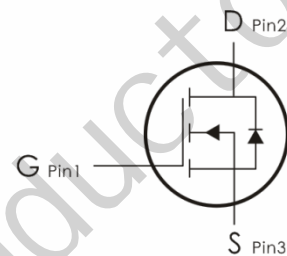
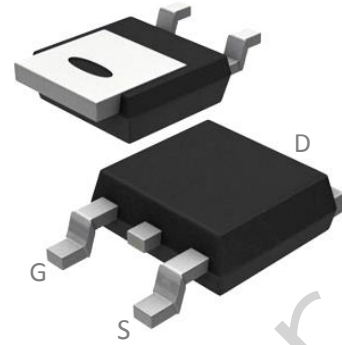

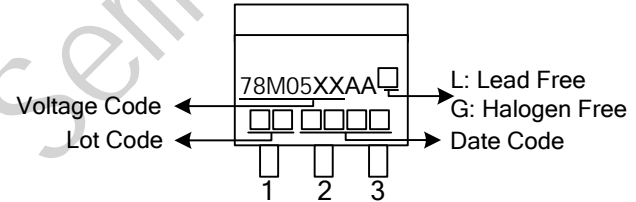
MARKING INFORMATION

PACKAGE	VOLTAGE CODE	MARKING
TO-252	05: 5V	
	06: 6V	
	08: 8V	
	09: 9V	
	10: 10V	
	12: 12V	
	15: 15V	
	18: 18V	

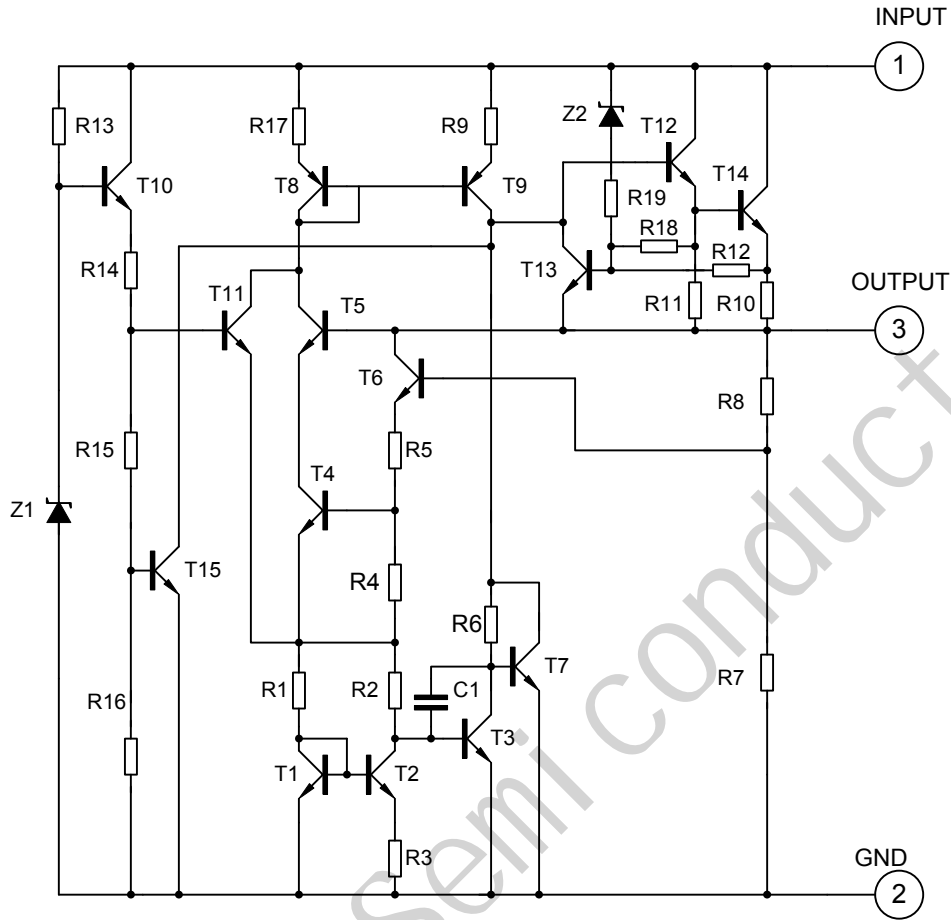
■ BLOCK DIAGRAM

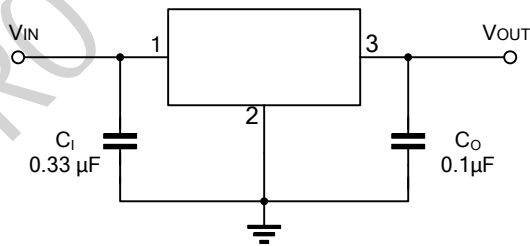

■ APPLICATION CIRCUIT



Note: Bypass capacitors are recommended for optimum stability and transient response and should be located as close as possible to the regulators.

■ ABSOLUTE MAXIMUM RATINGS ($T_A=25^{\circ}\text{C}$, unless otherwise specified)

PARAMETER	SYMBOL	RATINGS	UNIT
Input Voltage	V_{IN}	35	V
Output Current	I_{OUT}	1.5	A
Power Dissipation ($T_C=25^{\circ}\text{C}$)	P_D	10	W
Junction Temperature	T_J	+150	$^{\circ}\text{C}$
Operating Temperature	T_{OPR}	-40 ~ +85	$^{\circ}\text{C}$
Storage Temperature	T_{STG}	-55 ~ +150	$^{\circ}\text{C}$

Notes: 1. Absolute maximum ratings are stress ratings only and functional device operation is not implied. The device could be damaged beyond Absolute maximum ratings.

2. The maximum steady state usable output current are dependent on input voltage, heat sinking, lead length of the package and copper pattern of PCB. The data are showed as electrical characteristics table represents pulse test conditions with junction temperatures specified at the initiation of test.

■ THERMAL DATA

PARAMETER	SYMBOL	RATINGS	UNIT
Junction to Ambient	θ_{JA}	112	$^{\circ}\text{C/W}$
Junction to Case	θ_{JC}	12.5	$^{\circ}\text{C/W}$

■ ELECTRICAL CHARACTERISTICS

($T_J=25^{\circ}\text{C}$, $C_I=0.33\mu\text{F}$, $C_O=0.1\mu\text{F}$, $P_D\leq 15\text{W}$, unless otherwise specified)

For 78D05AA ($V_{IN}=10\text{V}$, $I_{OUT}=0.5\text{A}$)

PARAMETER	SYMBOL	TEST CONDITIONS	MIN	TYP	MAX	UNIT
Output Voltage	V_{OUT}	$I_{OUT}=5\text{mA}\sim 1.0\text{A}$	4.80	5.0	5.20	V
		$V_{IN}=7.5\sim 20\text{V}$, $I_{OUT}=5\text{mA}\sim 1.0\text{A}$	4.75		5.25	V
Load Regulation	ΔV_{OUT}	$I_{OUT}=5\text{mA}\sim 1.5\text{A}$			50	mV
		$I_{OUT}=0.25\text{A}\sim 0.75\text{A}$			25	mV
Line Regulation	ΔV_{OUT}	$V_{IN}=7\sim 25\text{V}$			50	mV
		$V_{IN}=7.5\sim 20\text{V}$, $I_{OUT}=1.0\text{A}$			50	mV
Quiescent Current	I_Q	$I_{OUT}\leq 1.0\text{A}$			8.0	mA
Quiescent Current Change	ΔI_Q	$V_{IN}=7.5\sim 20\text{V}$			1.0	mA
		$I_{OUT}=5\text{mA}\sim 1.0\text{A}$			0.5	mA
Output Noise Voltage	eN	$10\text{Hz}\leq f\leq 100\text{kHz}$		40		μV
Temperature coefficient of V_{OUT}	$\Delta V_{OUT}/\Delta T$	$I_{OUT}=5\text{mA}$		-0.6		$\text{mV}/^{\circ}\text{C}$
Ripple Rejection	RR	$V_{IN}=8\sim 18\text{V}$, $f=120\text{Hz}$	62	80		dB
Peak Output Current	I_{PEAK}			1.8		A
Short-Circuit Current	I_{SC}	$V_{IN}=35\text{V}$		250		mA
Dropout Voltage	V_D			2.0		V

■ ELECTRICAL CHARACTERISTICS(Cont.)

For 78D06AA ($V_{IN} = 11V, I_{OUT} = 0.5A$)

PARAMETER	SYMBOL	TEST CONDITIONS	MIN	TYP	MAX	UNIT
Output Voltage	V_{OUT}	$I_{OUT} = 5mA \sim 1.0A$	5.76	6.0	6.24	V
		$V_{IN} = 8.5 \sim 21V, I_{OUT} = 5mA \sim 1.0A$	5.7		6.3	V
Load Regulation	ΔV_{OUT}	$I_{OUT} = 5mA \sim 1.5A$			60	mV
		$I_{OUT} = 0.25A \sim 0.75A$			30	mV
Line Regulation	ΔV_{OUT}	$V_{IN} = 8 \sim 25V$			60	mV
		$V_{IN} = 8.5 \sim 21V, I_{OUT} = 1.0A$			60	mV
Quiescent Current	I_Q	$I_{OUT} \leq 1.0A$			8.0	mA
Quiescent Current Change	ΔI_Q	$V_{IN} = 8.5 \sim 21V$			1.0	mA
		$I_{OUT} = 5mA \sim 1.0A$			0.5	mA
Output Noise Voltage	eN	$10Hz \leq f \leq 100kHz$		45		μV
Temperature coefficient of V_{OUT}	$\Delta V_{OUT}/\Delta T$	$I_{OUT} = 5mA$		-0.7		mV/ $^{\circ}C$
Ripple Rejection	RR	$V_{IN} = 9 \sim 19V, f = 120Hz$	59	75		dB
Peak Output Current	I_{PEAK}			1.8		A
Short-Circuit Current	I_{SC}	$V_{IN} = 35V$		250		mA
Dropout Voltage	V_D			2.0		V

For 78D07AA ($V_{IN} = 13V, I_{OUT} = 0.5A$)

PARAMETER	SYMBOL	TEST CONDITIONS	MIN	TYP	MAX	UNIT
Output Voltage	V_{OUT}	$I_{OUT} = 5mA \sim 1.0A$	6.72	7.0	7.28	V
		$V_{IN} = 9.5 \sim 22V, I_{OUT} = 5mA \sim 1.0A$	6.65		7.35	V
Load Regulation	ΔV_{OUT}	$I_{OUT} = 5mA \sim 1.5A$			70	mV
		$I_{OUT} = 0.25A \sim 0.75A$			35	mV
Line Regulation	ΔV_{OUT}	$V_{IN} = 9 \sim 25V$			70	mV
		$V_{IN} = 9.5 \sim 22V, I_{OUT} = 1.0A$			70	mV
Quiescent Current	I_Q	$I_{OUT} \leq 1.0A$			8.0	mA
Quiescent Current Change	ΔI_Q	$V_{IN} = 9.5 \sim 22V$			1.0	mA
		$I_{OUT} = 5mA \sim 1.0A$			0.5	mA
Output Noise Voltage	eN	$10Hz \leq f \leq 100kHz$		50		μV
Temperature coefficient of V_{OUT}	$\Delta V_{OUT}/\Delta T$	$I_{OUT} = 5mA$		-0.8		mV/ $^{\circ}C$
Ripple Rejection	RR	$V_{IN} = 10 \sim 20V, f = 120Hz$	59	75		dB
Peak Output Current	I_{PEAK}			1.7		A
Short-Circuit Current	I_{SC}	$V_{IN} = 35V$		250		mA
Dropout Voltage	V_D			2.0		V

For 78D08AA ($V_{IN} = 14V, I_{OUT} = 0.5A$)

PARAMETER	SYMBOL	TEST CONDITIONS	MIN	TYP	MAX	UNIT
Output Voltage	V_{OUT}	$I_{OUT} = 5mA \sim 1.0A$	7.68	8.0	8.32	V
		$V_{IN} = 10.5 \sim 23V, I_{OUT} = 5mA \sim 1.0A$	7.6		8.4	V
Load Regulation	ΔV_{OUT}	$I_{OUT} = 5mA \sim 1.5A$			80	mV
		$I_{OUT} = 0.25A \sim 0.75A$			40	mV
Line Regulation	ΔV_{OUT}	$V_{IN} = 10.5 \sim 25V$			80	mV
		$V_{IN} = 10.5 \sim 23V, I_{OUT} = 1.0A$			80	mV
Quiescent Current	I_Q	$I_{OUT} \leq 1.0A$			8.0	mA
Quiescent Current Change	ΔI_Q	$V_{IN} = 10.5 \sim 23V$			1.0	mA
		$I_{OUT} = 5mA \sim 1.0A$			0.5	mA
Output Noise Voltage	eN	$10Hz \leq f \leq 100kHz$		58		μV
Temperature coefficient of V_{OUT}	$\Delta V_{OUT}/\Delta T$	$I_{OUT} = 5mA$		-0.9		mV/ $^{\circ}C$
Ripple Rejection	RR	$V_{IN} = 11.5 \sim 21.5V, f = 120Hz$	56	72		dB
Peak Output Current	I_{PEAK}			1.8		A
Short-Circuit Current	I_{SC}	$V_{IN} = 35V$		250		mA
Dropout Voltage	V_D			2.0		V

■ ELECTRICAL CHARACTERISTICS(Cont.)

For 78D09AA ($V_{IN} = 15V, I_{OUT} = 0.5A$)

PARAMETER	SYMBOL	TEST CONDITIONS	MIN	TYP	MAX	UNIT
Output Voltage	V_{OUT}	$I_{OUT} = 5mA \sim 1.0A$	8.64	9.0	9.36	V
		$V_{IN} = 11.5 \sim 24V, I_{OUT} = 5mA \sim 1.0A$	8.55		9.45	V
Load Regulation	ΔV_{OUT}	$I_{OUT} = 5mA \sim 1.5A$			90	mV
		$I_{OUT} = 0.25A \sim 0.75A$			45	mV
Line Regulation	ΔV_{OUT}	$V_{IN} = 11.5 \sim 25V$			90	mV
		$V_{IN} = 11.5 \sim 24V, I_{OUT} = 1.0A$			90	mV
Quiescent Current	I_Q	$I_{OUT} \leq 1.0A$			8.0	mA
Quiescent Current Change	ΔI_Q	$V_{IN} = 11.5 \sim 24V$			1.0	mA
		$I_{OUT} = 5mA \sim 1.0A$			0.5	mA
Output Noise Voltage	eN	$10Hz \leq f \leq 100kHz$		58		μV
Temperature coefficient of V_{OUT}	$\Delta V_{OUT}/\Delta T$	$I_{OUT} = 5mA$		-1.1		mV/°C
Ripple Rejection	RR	$V_{IN} = 12.5 \sim 22.5V, f = 120Hz$	56	72		dB
Peak Output Current	I_{PEAK}			1.8		A
Short-Circuit Current	I_{SC}	$V_{IN} = 35V$		250		mA
Dropout Voltage	V_D			2.0		V

For 78D10AA ($V_{IN} = 16V, I_{OUT} = 0.5A$)

PARAMETER	SYMBOL	TEST CONDITIONS	MIN	TYP	MAX	UNIT
Output Voltage	V_{OUT}	$I_{OUT} = 5mA \sim 1.0A$	9.60	10.0	10.40	V
		$V_{IN} = 12.5 \sim 25V, I_{OUT} = 5mA \sim 1.0A$	9.5		10.5	V
Load Regulation	ΔV_{OUT}	$I_{OUT} = 5mA \sim 1.5A$			100	mV
		$I_{OUT} = 0.25A \sim 0.75A$			50	mV
Line Regulation	ΔV_{OUT}	$V_{IN} = 13 \sim 25V$			100	mV
		$V_{IN} = 13 \sim 25V, I_{OUT} = 1.0A$			100	mV
Quiescent Current	I_Q	$I_{OUT} \leq 1.0A$			8.0	mA
Quiescent Current Change	ΔI_Q	$V_{IN} = 12.6V \sim 25V$			1.0	mA
		$I_{OUT} = 5mA \sim 1.0A$			0.5	mA
Output Noise Voltage	eN	$10Hz \leq f \leq 100kHz$		58		μV
Temperature coefficient of V_{OUT}	$\Delta V_{OUT}/\Delta T$	$I_{OUT} = 5mA$		-1.1		mV/°C
Ripple Rejection	RR	$V_{IN} = 13 \sim 23V, f = 120Hz$	56	72		dB
Peak Output Current	I_{PEAK}			1.8		A
Short-Circuit Current	I_{SC}	$V_{IN} = 35V$		250		mA
Dropout Voltage	V_D			2.0		V

For 78D12AA ($V_{IN} = 19V, I_{OUT} = 0.5A$)

PARAMETER	SYMBOL	TEST CONDITIONS	MIN	TYP	MAX	UNIT
Output Voltage	V_{OUT}	$I_{OUT} = 5mA \sim 1.0A$	11.52	12.0	12.48	V
		$V_{IN} = 14.5 \sim 27V, I_{OUT} = 5mA \sim 1.0A$	11.4		12.6	V
Load Regulation	ΔV_{OUT}	$I_{OUT} = 5mA \sim 1.5A$			120	mV
		$I_{OUT} = 0.25A \sim 0.75A$			60	mV
Line Regulation	ΔV_{OUT}	$V_{IN} = 14.5 \sim 30V$			120	mV
		$V_{IN} = 14.6 \sim 27V, I_{OUT} = 1.0A$			120	mV
Quiescent Current	I_Q	$I_{OUT} \leq 1.0A$			8.0	mA
Quiescent Current Change	ΔI_Q	$V_{IN} = 14.5 \sim 30V$			1.0	mA
		$I_{OUT} = 5mA \sim 1.0A$			0.5	mA
Output Noise Voltage	eN	$10Hz \leq f \leq 100kHz$		75		μV
Temperature coefficient of V_{OUT}	$\Delta V_{OUT}/\Delta T$	$I_{OUT} = 5mA$		-1.5		mV/°C
Ripple Rejection	RR	$V_{IN} = 15 \sim 25V, f = 120Hz$	55	72		dB
Peak Output Current	I_{PEAK}			1.8		A
Short-Circuit Current	I_{SC}	$V_{IN} = 35V$		250		mA
Dropout Voltage	V_D			2.0		V

■ ELECTRICAL CHARACTERISTICS(Cont.)

 For 78D15AA ($V_{IN} = 23V$, $I_{OUT} = 0.5A$)

PARAMETER	SYMBOL	TEST CONDITIONS	MIN	TYP	MAX	UNIT
Output Voltage	V_{OUT}	$I_{OUT} = 5mA \sim 1.0A$	14.40	15.0	15.6	V
		$V_{IN} = 17.5 \sim 30V$, $I_{OUT} = 5mA \sim 1.0A$	14.25		15.75	V
Load Regulation	ΔV_{OUT}	$I_{OUT} = 5mA \sim 1.5A$			150	mV
		$I_{OUT} = 0.25A \sim 0.75A$			75	mV
Line Regulation	ΔV_{OUT}	$V_{IN} = 18.5 \sim 30V$			150	mV
		$V_{IN} = 17.7 \sim 30V$, $I_{OUT} = 1.0A$			150	mV
Quiescent Current	I_Q	$I_{OUT} \leq 1.0A$			8.0	mA
Quiescent Current Change	ΔI_Q	$V_{IN} = 17.5 \sim 30V$			1.0	mA
		$I_{OUT} = 5mA \sim 1.0A$			0.5	mA
Output Noise Voltage	eN	$10Hz \leq f \leq 100kHz$		90		μV
Temperature coefficient of V_{OUT}	$\Delta V_{OUT}/\Delta T$	$I_{OUT} = 5mA$		-1.8		$mV/^\circ C$
Ripple Rejection	RR	$V_{IN} = 18.5 \sim 28.5V$, $f = 120Hz$	54	70		dB
Peak Output Current	I_{PEAK}			1.8		A
Short-Circuit Current	I_{SC}	$V_{IN} = 35V$		250		mA
Dropout Voltage	V_D			2.0		V

 For 78D18AA ($V_{IN} = 27V$, $I_{OUT} = 0.5A$)

PARAMETER	SYMBOL	TEST CONDITIONS	MIN	TYP	MAX	UNIT
Output Voltage	V_{OUT}	$I_{OUT} = 5mA \sim 1.0A$	17.28	18.0	18.72	V
		$V_{IN} = 21 \sim 33V$, $I_{OUT} = 5mA \sim 1.0A$	17.1		18.9	V
Load Regulation	ΔV_{OUT}	$I_{OUT} = 5mA \sim 1.5A$			180	mV
		$I_{OUT} = 0.25A \sim 0.75A$			90	mV
Line Regulation	ΔV_{OUT}	$V_{IN} = 21 \sim 33V$			180	mV
		$V_{IN} = 21 \sim 33V$, $I_{OUT} = 1.0A$			180	mV
Quiescent Current	I_Q	$I_{OUT} \leq 1.0A$			8.0	mA
Quiescent Current Change	ΔI_Q	$V_{IN} = 21.5 \sim 33V$			1.0	mA
		$I_{OUT} = 5mA \sim 1.0A$			0.5	mA
Output Noise Voltage	eN	$10Hz \leq f \leq 100kHz$		110		μV
Temperature coefficient of V_{OUT}	$\Delta V_{OUT}/\Delta T$	$I_{OUT} = 5mA$		-2.2		$mV/^\circ C$
Ripple Rejection	RR	$V_{IN} = 22 \sim 32V$, $f = 120Hz$	53	69		dB
Peak Output Current	I_{PEAK}			1.8		A
Short-Circuit Current	I_{SC}	$V_{IN} = 35V$		250		mA
Dropout Voltage	V_D			2.0		V

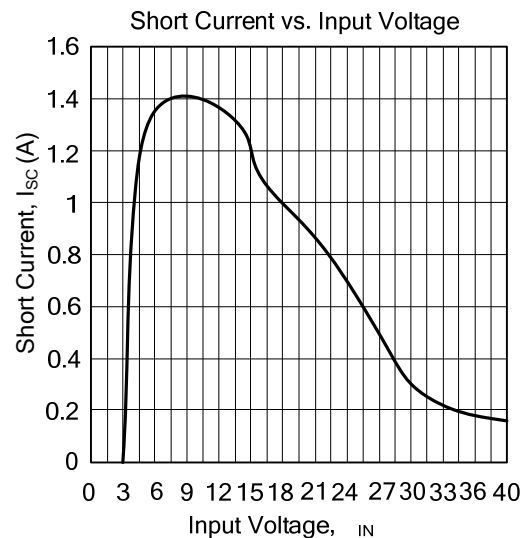
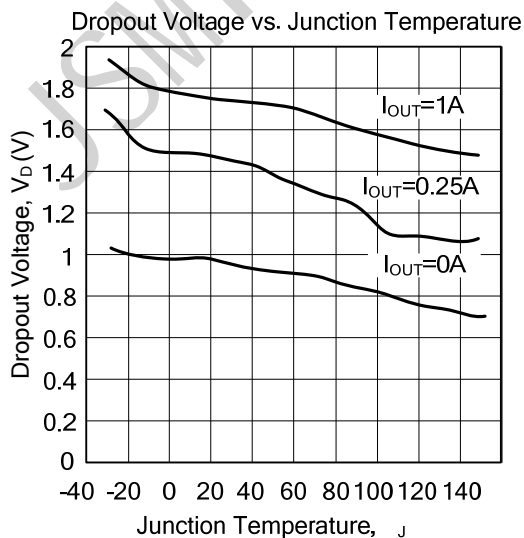
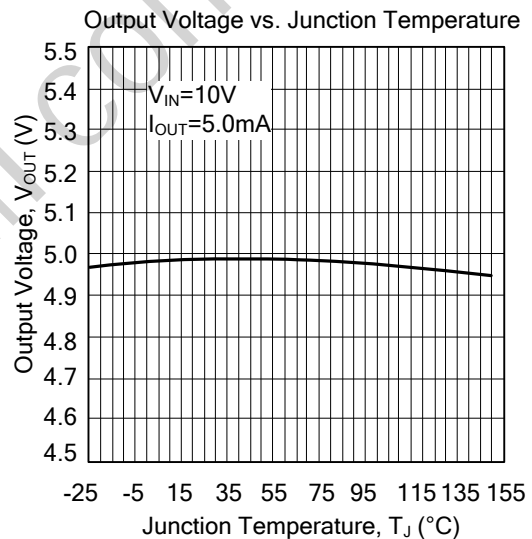
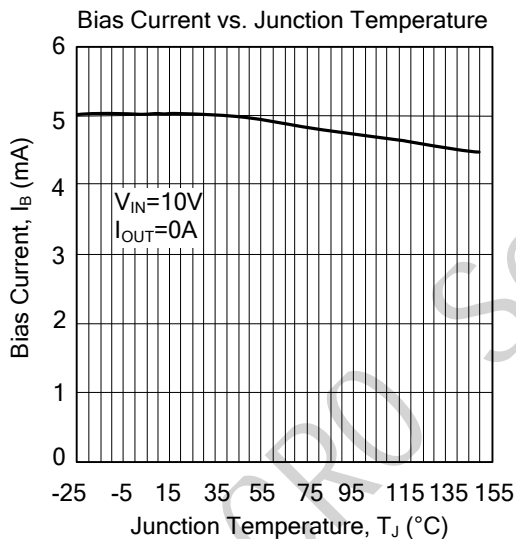
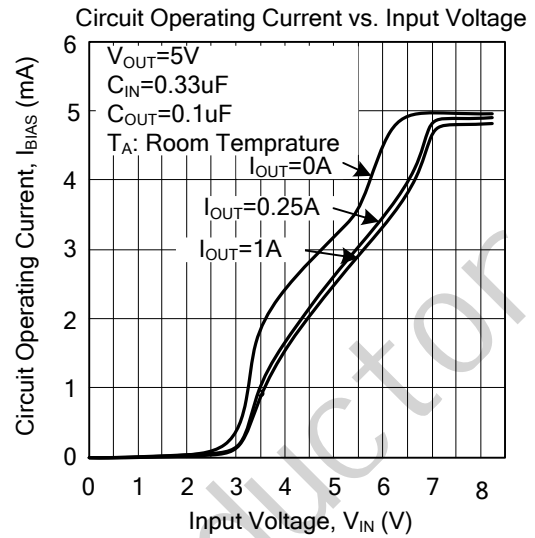
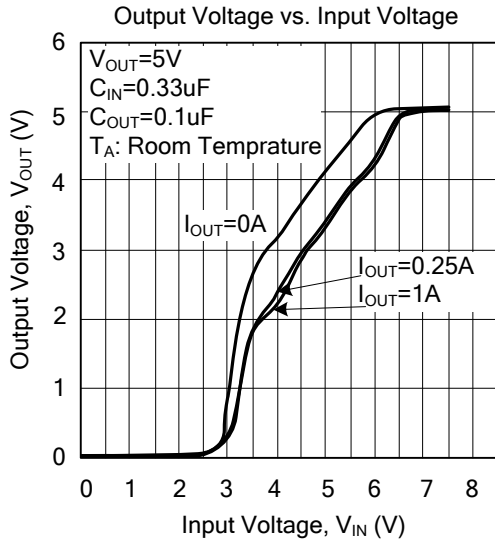
TYPICAL CHARACTERISTICS

■ TYPICAL CHARACTERISTICS(Cont.)

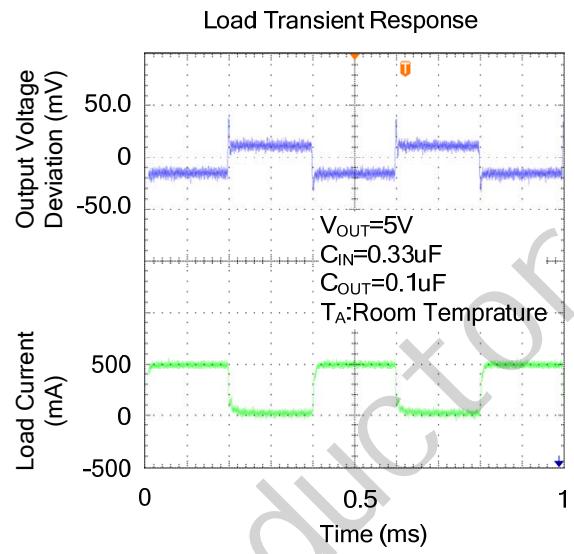
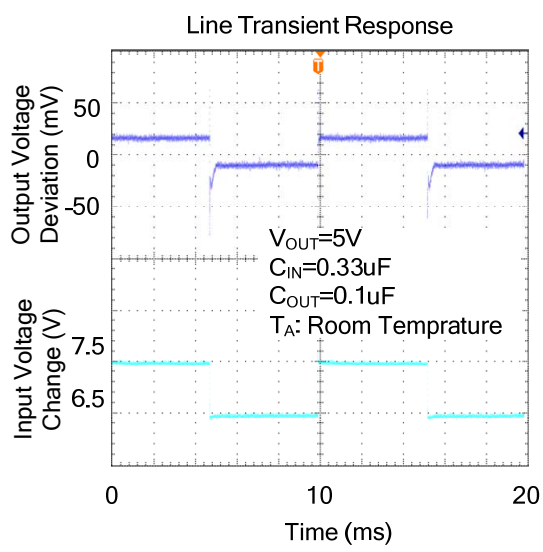

外形尺寸图 / Package Dimensions

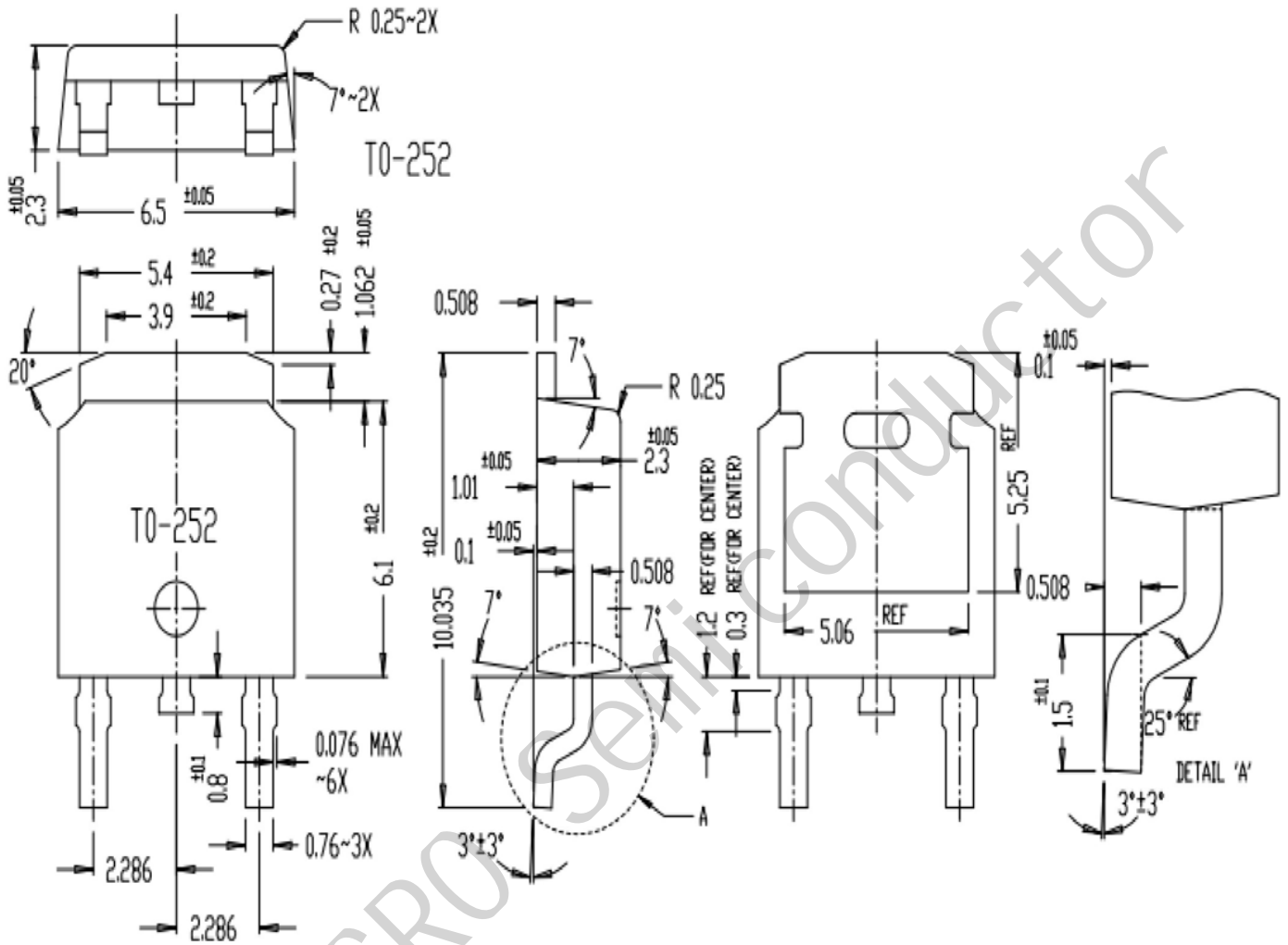

X-ON Electronics

Largest Supplier of Electrical and Electronic Components

Click to view similar products for [MOSFET](#) category:

Click to view products by [JSMSEMI](#) manufacturer:

Other Similar products are found below :

[IRFD120](#) [JANTX2N5237](#) [2SK2267\(Q\)](#) [BUK455-60A/B](#) [TK100A10N1,S4X\(S](#) [MIC4420CM-TR](#) [VN1206L](#) [NDP4060](#) [SI4482DY](#)
[IRS2092STRPBF-EL](#) [IPS70R2K0CEAKMA1](#) [TK31J60W5,S1VQ\(O](#) [TK31J60W,S1VQ\(O](#) [TK16J60W,S1VQ\(O](#) [2SK2614\(TE16L1,Q\)](#)
[DMN1017UCP3-7](#) [EFC2J004NUZTDG](#) [P85W28HP2F-7071](#) [DMN1053UCP4-7](#) [NTE2384](#) [DMC2700UDMQ-7](#) [DMN2080UCB4-7](#)
[DMN61D9UWQ-13](#) [US6M2GTR](#) [DMN31D5UDJ-7](#) [DMP22D4UFO-7B](#) [IPS60R3K4CEAKMA1](#) [DMN1006UCA6-7](#) [DMN16M9UCA6-7](#)
[STF5N65M6](#) [IRF40H233XTMA1](#) [STU5N65M6](#) [DMN6022SSD-13](#) [DMN13M9UCA6-7](#) [DMTH10H4M6SPS-13](#) [IPS60R360PFD7SAKMA1](#)
[DMN2990UFB-7B](#) [SSM3K35CT,L3F](#) [IPLK60R1K0PFD7ATMA1](#) [2N7002W-G](#) [MCAC30N06Y-TP](#) [IPWS65R035CFD7AXKSA1](#)
[MCQ7328-TP](#) [SSM3J143TU,LXHF](#) [DMN12M3UCA6-7](#) [PJMF280N65E1_T0_00201](#) [PJMF380N65E1_T0_00201](#)
[PJMF280N60E1_T0_00201](#) [PJMF600N65E1_T0_00201](#) [PJMF900N65E1_T0_00201](#)