

General Description

The SI9801DY-T1-E3 uses advanced trench technology MOSFETs to provide excellent $R_{DS(ON)}$ and low gate charge. The complementary MOSFETs may be used in inverter and other applications.

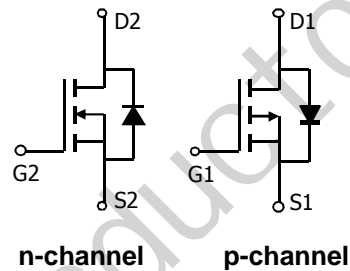
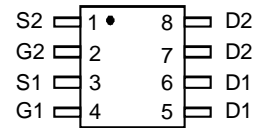
Features

n-channel	p-channel-
V_{DS} (V) = 30V	30V
I_D = 7.2A ($V_{GS}=10V$)	-6.8A ($V_{GS} = -10V$)
$R_{DS(ON)}$	$R_{DS(ON)}$
= 20m Ω ($V_{GS}=10V$)	=36m Ω ($V_{GS} = -10V$)
= 30m Ω ($V_{GS}=4.5V$)	= 48m Ω ($V_{GS} = -4.5V$)

100% UIS tested
 100% Rg tested

SOP-8L

Top View



Absolute Maximum Ratings $T_A=25^\circ\text{C}$ unless otherwise noted					
Parameter	Symbol	Max n-channel	Max p-channel	Units	
Drain-Source Voltage	V_{DS}	30	-30	V	
Gate-Source Voltage	V_{GS}	± 20	± 20	V	
Continuous Drain Current ^F	I_D	$T_A=25^\circ\text{C}$	7.2	A	
		$T_A=70^\circ\text{C}$	6.2		
Pulsed Drain Current ^B	I_{DM}	64	-40		
Power Dissipation ^F	P_D	$T_A=25^\circ\text{C}$	2	W	
		$T_A=70^\circ\text{C}$	1.44		
Avalanche Current ^B	I_{AR}	9	17	A	
Repetitive avalanche energy 0.3mH ^B	E_{AR}	12	43	mJ	
Junction and Storage Temperature Range	T_J, T_{STG}	-55 to 150	-55 to 150	$^\circ\text{C}$	
Thermal Characteristics: n-channel and p-channel					
Parameter	Symbol	Device	Typ	Max	Units
Maximum Junction-to-Ambient ^A	$R_{\theta JA}$	n-ch	50	62.5	$^\circ\text{C/W}$
Maximum Junction-to-Ambient ^A		Steady-State	n-ch	80	
Maximum Junction-to-Lead ^C	$R_{\theta JL}$	n-ch	32	40	$^\circ\text{C/W}$
Maximum Junction-to-Ambient ^A	$R_{\theta JA}$	p-ch	50	62.5	$^\circ\text{C/W}$
Maximum Junction-to-Ambient ^A		Steady-State	p-ch	80	
Maximum Junction-to-Lead ^C	$R_{\theta JL}$	p-ch	32	40	$^\circ\text{C/W}$

Notes: ESD rating--HBM1b, MSL Rating--MSL Level2

N-CHANNEL Electrical Characteristics (T_J=25°C unless otherwise noted)

Symbol	Parameter	Conditions	Min	Typ	Max	Units
STATIC PARAMETERS						
BV _{DSS}	Drain-Source Breakdown Voltage	I _D =250μA, V _{GS} =0V	30			V
I _{DSS}	Zero Gate Voltage Drain Current	V _{DS} =30V, V _{GS} =0V T _J =55°C			1 5	μA
I _{GSS}	Gate-Body leakage current	V _{DS} =0V, V _{GS} = ±20V			100	nA
V _{GS(th)}	Gate Threshold Voltage	V _{DS} =V _{GS} , I _D =250μA	1.0	1.5	2.6	V
I _{D(ON)}	On state drain current	V _{GS} =10V, V _{DS} =5V	64			A
R _{DS(ON)}	Static Drain-Source On-Resistance	V _{GS} =10V, I _D =7.2A T _J =125°C		18.7 25	28 32	mΩ
		V _{GS} =4.5V, I _D =5A		24.8	36	mΩ
g _{FS}	Forward Transconductance	V _{DS} =5V, I _D =7.2A		20		S
V _{SD}	Diode Forward Voltage	I _S =2.5A, V _{GS} =0V		0.74	1	V
I _S	Maximum Body-Diode Continuous Current				2.5	A
I _{SM}	Pulsed Body-Diode Current ^B				64	A
DYNAMIC PARAMETERS						
C _{iss}	Input Capacitance			373	448	pF
C _{oss}	Output Capacitance	V _{GS} =0V, V _{DS} =15V, f=1MHz		67		pF
C _{riss}	Reverse Transfer Capacitance			41		pF
R _g (Note.H)	Gate resistance	V _{GS} =0V, V _{DS} =0V, f=1MHz		1.8	2.8	Ω
SWITCHING PARAMETERS						
Q _g (10V)	Total Gate Charge			7.2	11	nC
Q _g (4.5V)	Total Gate Charge			3.5		nC
Q _{gs}	Gate Source Charge	V _{GS} =10V, V _{DS} =15V, I _D =7.2A		1.3		nC
Q _{gd}	Gate Drain Charge			1.7		nC
t _{D(on)}	Turn-On DelayTime			4.5		ns
t _r	Turn-On Rise Time	V _{GS} =10V, V _{DS} =15V, R _L =2.1Ω,		2.7		ns
t _{D(off)}	Turn-Off DelayTime	R _{GEN} =3Ω		14.9		ns
t _f	Turn-Off Fall Time			2.9		ns
t _{rr}	Body Diode Reverse Recovery Time	I _F =7.2A, dI/dt=100A/μs		10.5	12.6	ns
Q _{rr}	Body Diode Reverse Recovery Charge	I _F =7.2A, dI/dt=100A/μs		4.5		nC

A: The value of R_{θJA} is measured with the device mounted on 1in² FR-4 board with 2oz. Copper, in a still air environment with T_A=25° C. The value in any given application depends on the user's specific board design. The current rating is based on the t ≤ 10s thermal resistance rating.

B: Repetitive rating, pulse width limited by junction temperature.

C: The R_{θJA} is the sum of the thermal impedance from junction to lead R_{θJL} and lead to ambient.

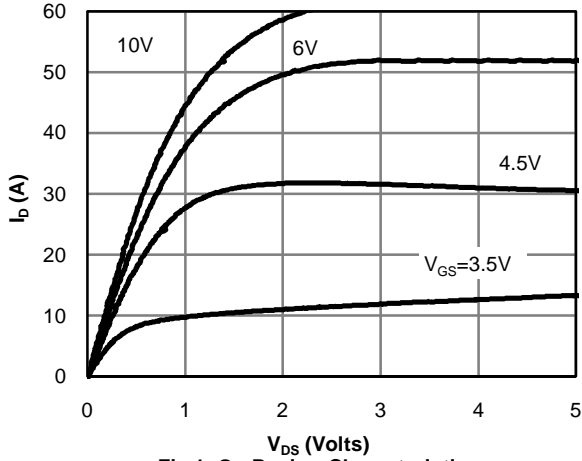
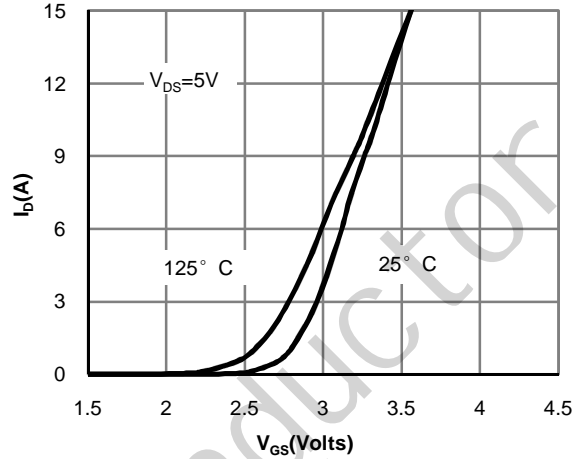
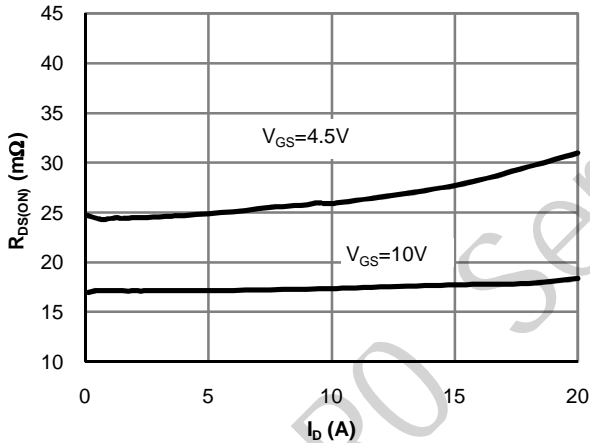
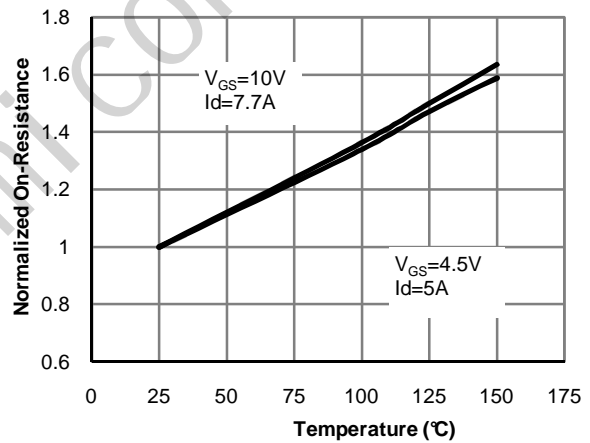
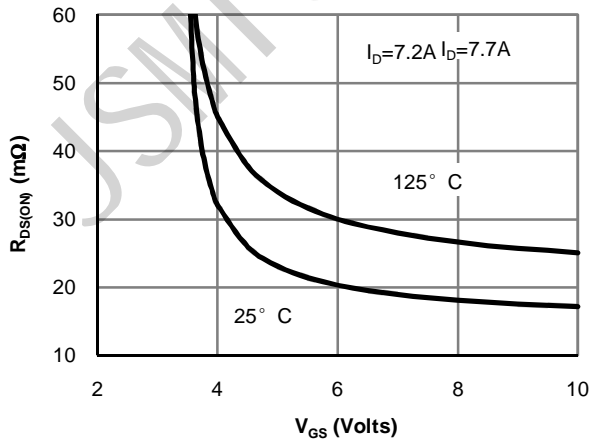
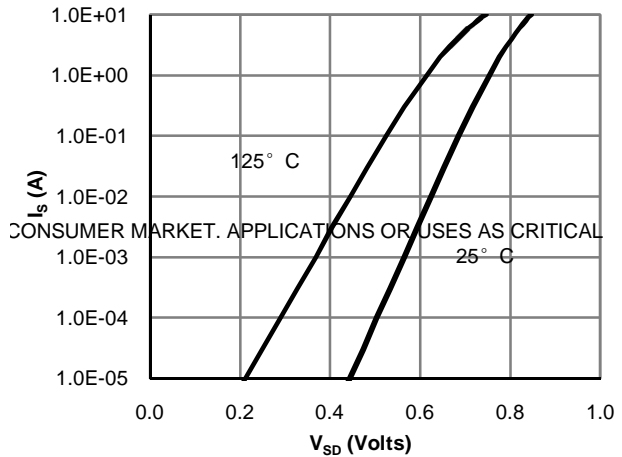
D: The static characteristics in Figures 1 to 6 are obtained using <300 μs pulses, duty cycle 0.5% max.

E: These tests are performed with the device mounted on 1 in² FR-4 board with 2oz. Copper, in a still air environment with T_A=25° C. The SOA curve provides a single pulse rating.

F: The power dissipation and current rating are based on the t ≤ 10s thermal resistance rating.

H: R_g detail test condition: V_{GS}=0V, V_{DS}=0V, V_{osc}=0.5V, f=1MHZ, CS is 0.001nF to 1000nF(CS limit is only for checking test contact)

Setup the test condition on R_g tester, then get the R_g value.

N-CHANNEL TYPICAL ELECTRICAL AND THERMAL CHARACTERISTICS

Fig 1: On-Region Characteristics

Figure 2: Transfer Characteristics

Figure 3: On-Resistance vs. Drain Current and Gate Voltage

Figure 4: On-Resistance vs. Junction Temperature

Figure 5: On-Resistance vs. Gate-Source Voltage

Figure 6: Body-Diode Characteristics

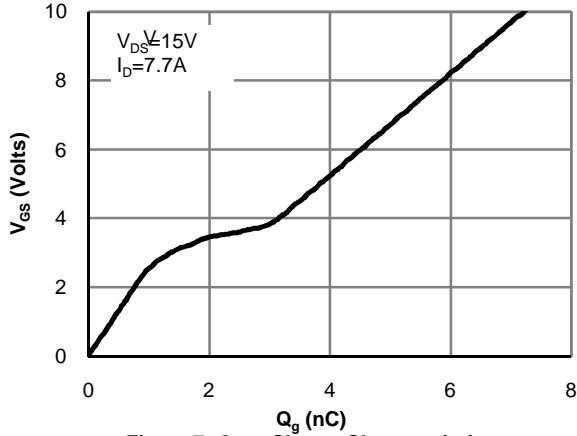
N-CHANNEL TYPICAL ELECTRICAL AND THERMAL CHARACTERISTICS


Figure 7: Gate-Charge Characteristics

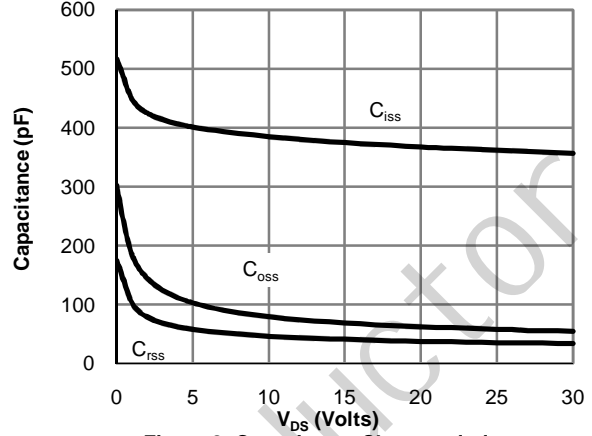


Figure 8: Capacitance Characteristics

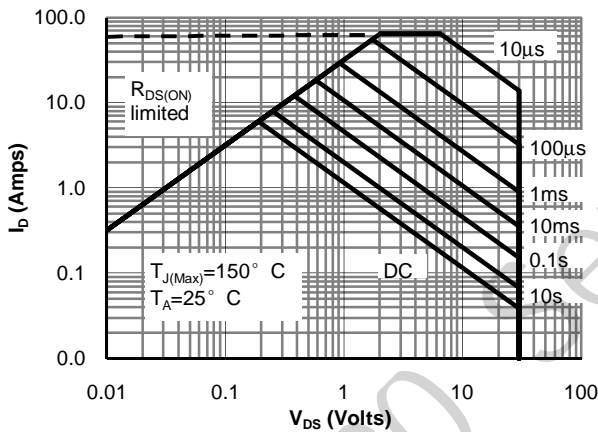


Figure 9: Maximum Forward Biased Safe Operating Area (Note E)

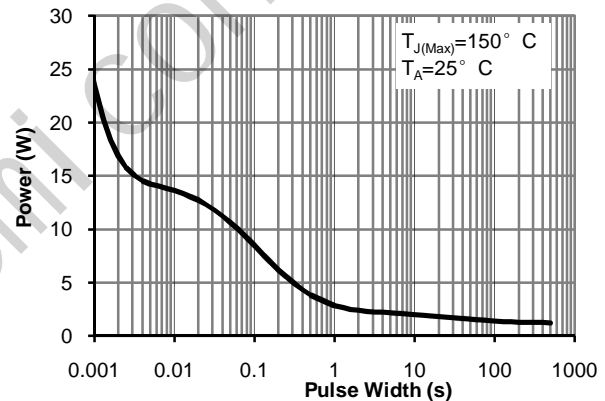


Figure 10: Single Pulse Power Rating Junction-to-Ambient (Note E)

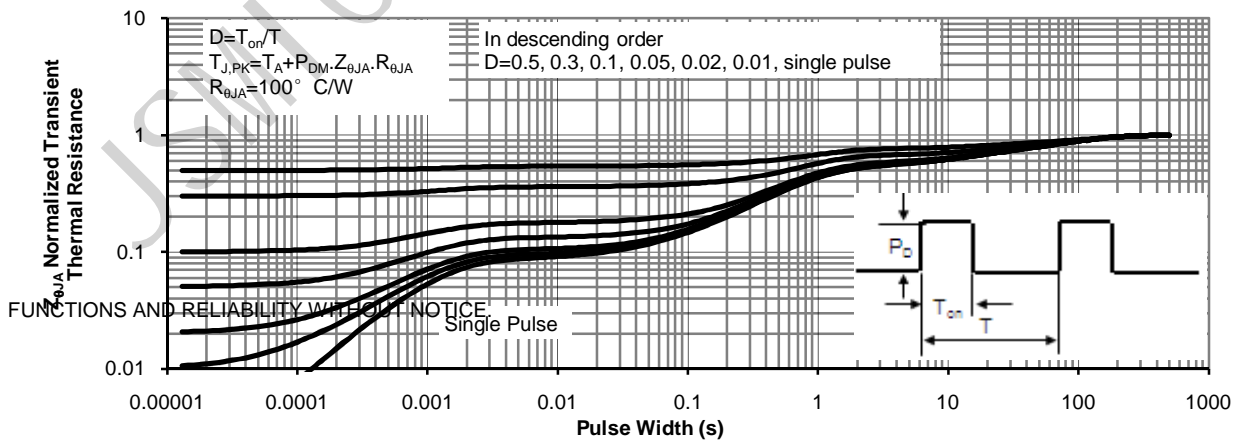


Figure 11: Normalized Maximum Transient Thermal Impedance

P-CHANNEL Electrical Characteristics (T_J=25°C unless otherwise noted)

Symbol	Parameter	Conditions	Min	Typ	Max	Units
STATIC PARAMETERS						
BV _{DSS}	Drain-Source Breakdown Voltage	I _D =-250μA, V _{GS} =0V	-30			V
I _{DSS}	Zero Gate Voltage Drain Current	V _{DS} =-30V, V _{GS} =0V T _J =55°C			-1 -5	μA
I _{GSS}	Gate-Body leakage current	V _{DS} =0V, V _{GS} =±20V			±100	nA
V _{GS(th)}	Gate Threshold Voltage	V _{DS} =V _{GS} , I _D =-250μA	-1.0	-1.50	-2.4	V
I _{D(ON)}	On state drain current	V _{GS} =-10V, V _{DS} =-5V	-40			A
R _{DS(ON)}	Static Drain-Source On-Resistance	V _{GS} =-10V, I _D =-6.3A T _J =125°C		36 31.5	48	mΩ
		V _{GS} =-4.5V, I _D =-3.5A		48	58	mΩ
g _{FS}	Forward Transconductance	V _{DS} =-5V, I _D =-5.3A		19		S
V _{SD}	Diode Forward Voltage	I _S =-3.5A, V _{GS} =0V		-0.8	-1	V
I _S	Maximum Body-Diode Continuous Current				-3.5	A
I _{SM}	Pulsed Body-Diode Current ^B				-40	A
DYNAMIC PARAMETERS						
C _{iss}	Input Capacitance	V _{GS} =0V, V _{DS} =-15V, f=1MHz		760		pF
C _{oss}	Output Capacitance			140		pF
C _{rss}	Reverse Transfer Capacitance			95		pF
R _{g (Note.H)}	Gate resistance	V _{GS} =0V, V _{DS} =0V, f=1MHz		3.2	5	Ω
SWITCHING PARAMETERS						
Q _{g(10V)}	Total Gate Charge (10V)	V _{GS} =-10V, V _{DS} =-15V, I _D =-5.3A		13.6	16	nC
Q _{g(4.5V)}	Total Gate Charge (4.5V)			6.7		nC
Q _{gs}	Gate Source Charge			2.5		nC
Q _{gd}	Gate Drain Charge			3.2		nC
t _{D(on)}	Turn-On DelayTime			8		ns
t _r	Turn-On Rise Time	V _{GS} =-10V, V _{DS} =-15V, R _L =2.8Ω, R _{GEN} =3Ω		6		ns
t _{D(off)}	Turn-Off DelayTime			17		ns
t _f	Turn-Off Fall Time			5		ns
t _{rr}	Body Diode Reverse Recovery Time	I _F =-5.3A, dI/dt=100A/μs		15		ns
Q _{rr}	Body Diode Reverse Recovery Charge	I _F =-5.3A, dI/dt=100A/μs		9.7		nC

A: The value of R_{θJA} is measured with the device mounted on 1in² FR-4 board with 2oz. Copper, in a still air environment with T_A=25° C. The value in any given application depends on the user's specific board design. The current rating is based on the t ≤ 10s thermal resistance rating.

B: Repetitive rating, pulse width limited by junction temperature.

C: The R_{θJA} is the sum of the thermal impedance from junction to lead R_{θJL} and lead to ambient.

D: The static characteristics in Figures 1 to 6 are obtained using <300 μs pulses, duty cycle 0.5% max.

E: These tests are performed with the device mounted on 1 in² FR-4 board with 2oz. Copper, in a still air environment with T_A=25° C. The SOA curve provides a single pulse rating.

F: The current rating is based on the t ≤ 10s thermal resistance rating.

H: R_g detail test condition: V_{GS}=0V, V_{DS}=0V, V_{osc}=0.5V, f=1MHZ, CS is 0.001nF to 1000nF(CS limit is only for checking test contact)

Setup the test condition on R_g tester, then get the R_g value.

P-CHANNEL TYPICAL ELECTRICAL AND THERMAL CHARACTERISTICS

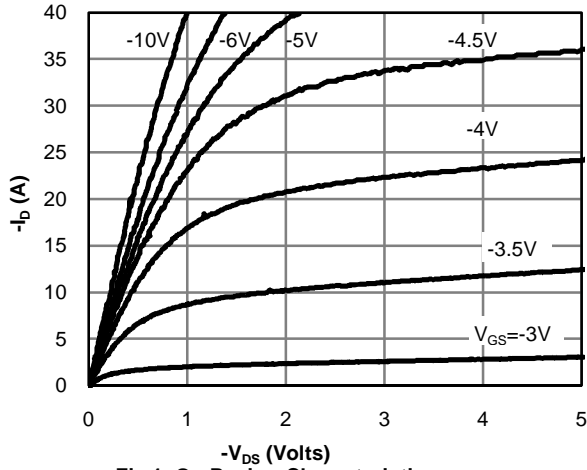


Fig 1: On-Region Characteristics

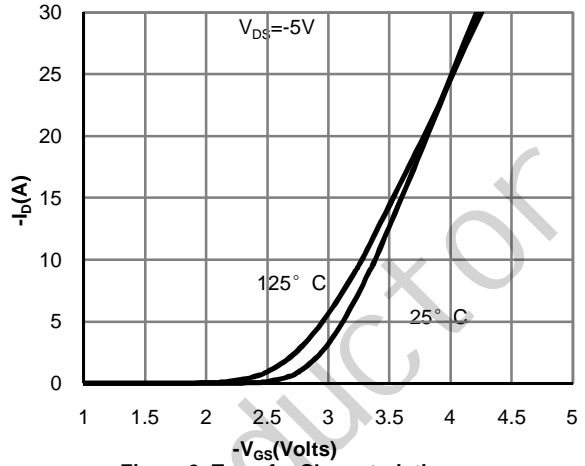


Figure 2: Transfer Characteristics

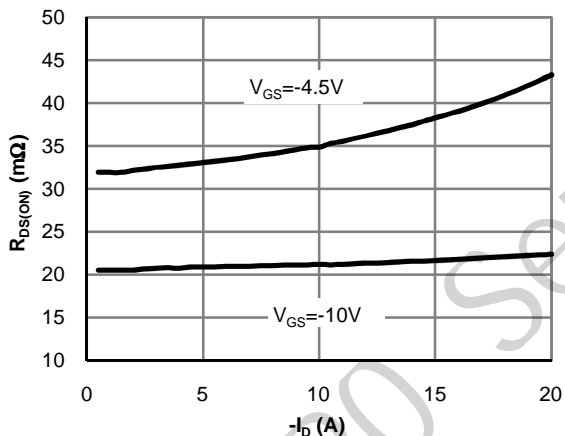


Figure 3: On-Resistance vs. Drain Current and Gate Voltage

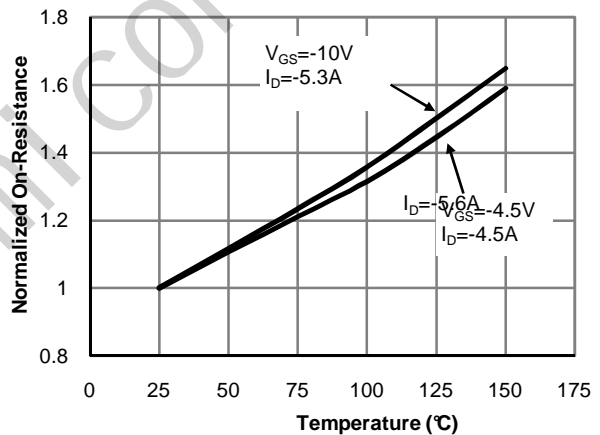


Figure 4: On-Resistance vs. Junction Temperature

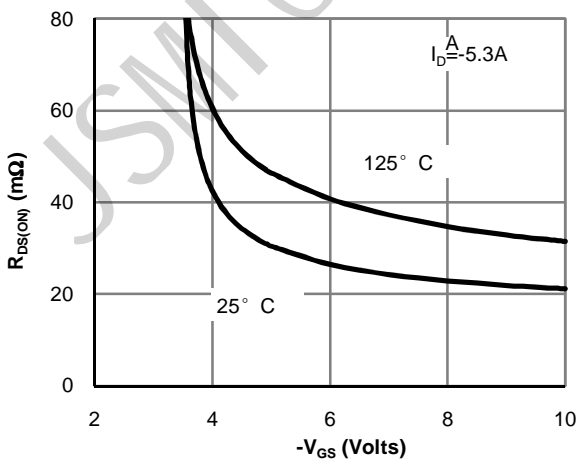


Figure 5: On-Resistance vs. Gate-Source Voltage

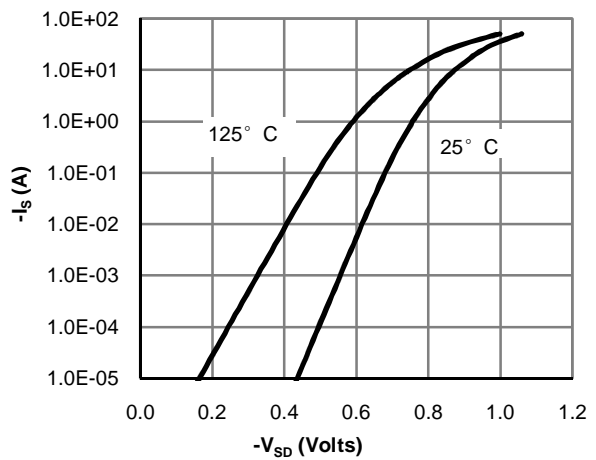


Figure 6: Body-Diode Characteristics

P-CHANNEL TYPICAL ELECTRICAL AND THERMAL CHARACTERISTICS

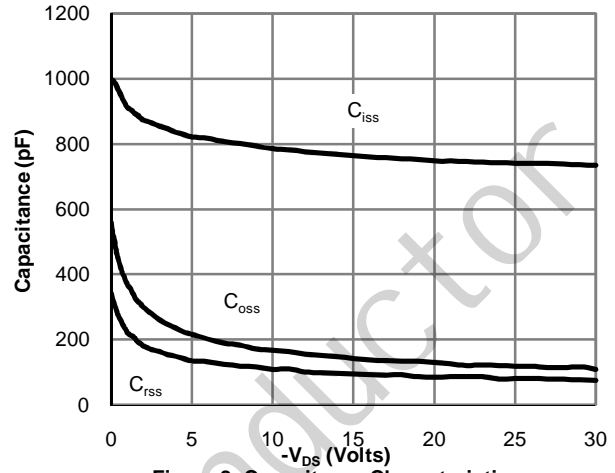
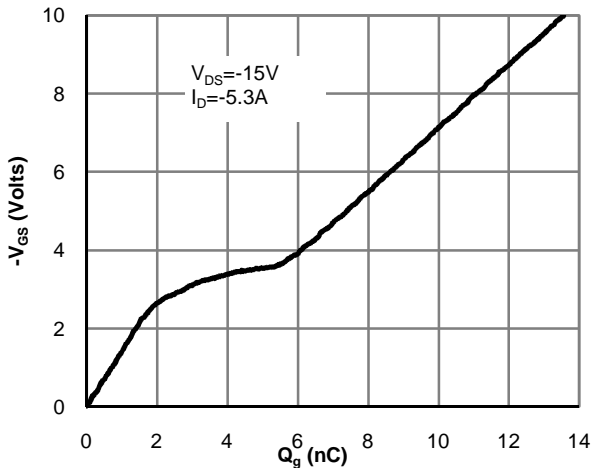


Figure 8: Capacitance Characteristics

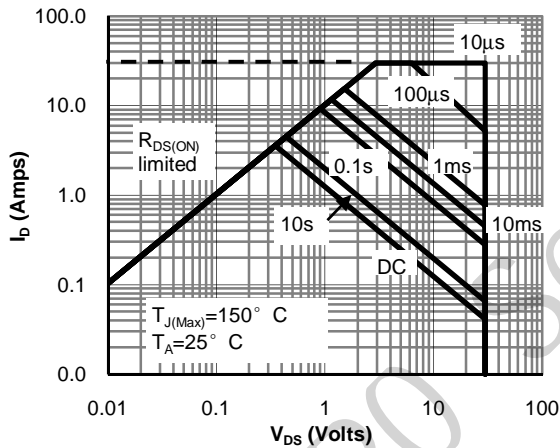


Figure 9: Maximum Forward Biased Safe Operating Area (Note E)

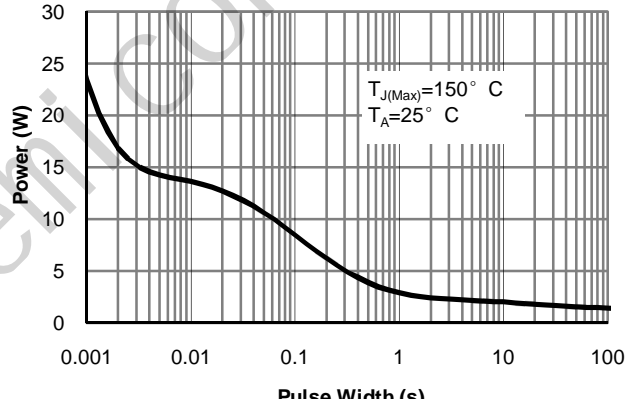


Figure 10: Single Pulse Power Rating Junction-to-Ambient (Note E)

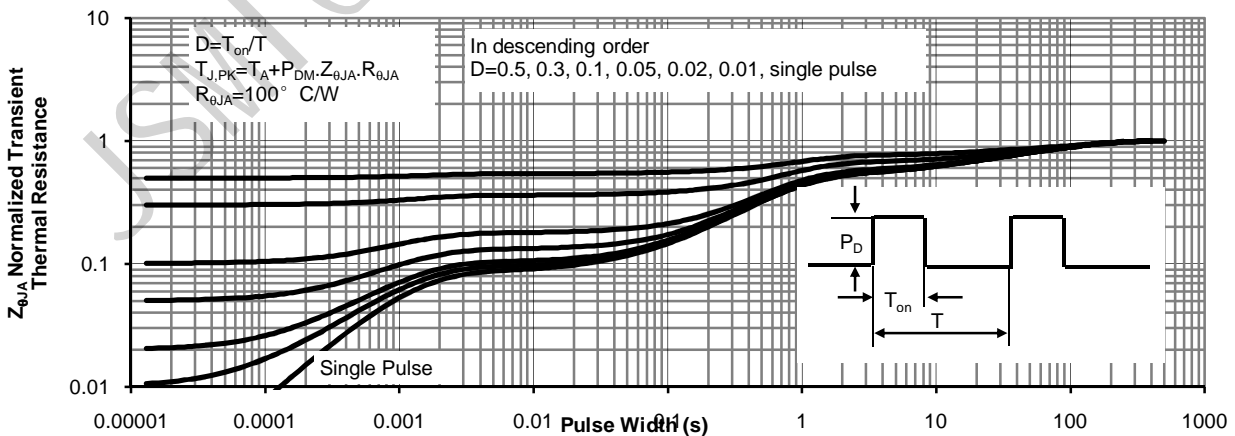
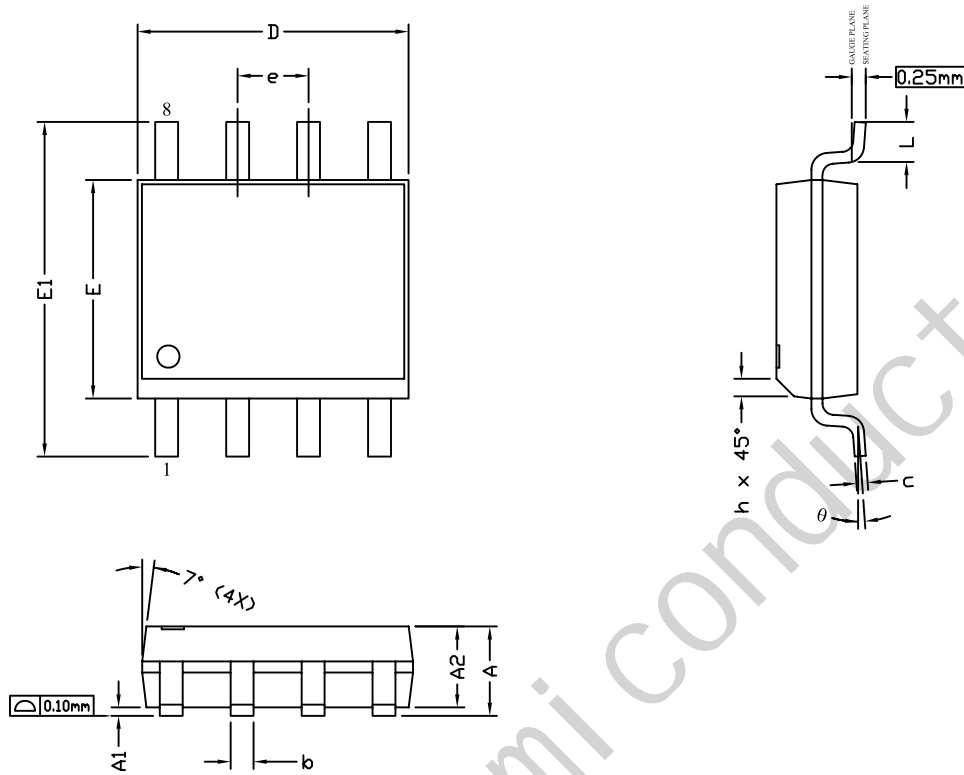
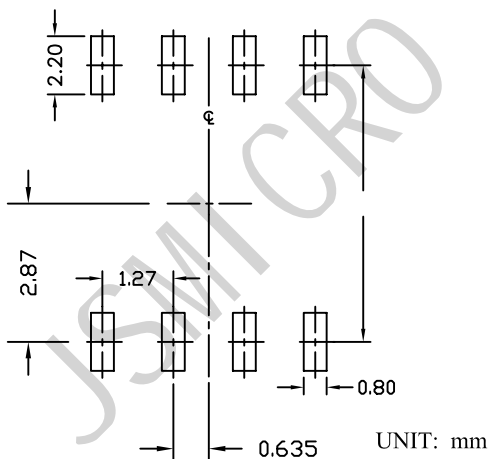


Figure 11: Normalized Maximum Transient Thermal Impedance

■ SOP8 PACKAGE OUTLINE DIMENSIONS



RECOMMENDED LAND PATTERN



SYMBOLS	DIMENSIONS IN MILLIMETERS			DIMENSIONS IN INCHES		
	MIN	NOM	MAX	MIN	NOM	MAX
A	1.35	1.65	1.75	0.053	0.065	0.069
A1	0.10	—	0.25	0.004	—	0.010
A2	1.25	1.50	1.65	0.049	0.059	0.065
b	0.31	—	0.51	0.012	—	0.020
c	0.17	—	0.25	0.007	—	0.010
D	4.80	4.90	5.00	0.189	0.193	0.197
E	3.80	3.90	4.00	0.150	0.154	0.157
e	1.27 BSC			0.050 BSC		
E1	5.80	6.00	6.20	0.228	0.236	0.244
h	0.25	—	0.50	0.010	—	0.020
L	0.40	—	1.27	0.016	—	0.050
θ	0°	—	8°	0°	—	8°

NOTE

1. ALL DIMENSIONS ARE IN MILLIMETERS.
2. DIMENSIONS ARE INCLUSIVE OF PLATING.
3. PACKAGE BODY SIZES EXCLUDE MOLD FLASH AND GATE BURRS.
MOLD FLASH AT THE NON-LEAD SIDES SHOULD BE LESS THAN 6 MILS EACH.
4. DIMENSION L IS MEASURED IN GAUGE PLANE.
5. CONTROLLING DIMENSION IS MILLIMETER.
CONVERTED INCH DIMENSIONS ARE NOT NECESSARILY EXACT.

X-ON Electronics

Largest Supplier of Electrical and Electronic Components

Click to view similar products for [MOSFET](#) category:

Click to view products by [JSMSEMI](#) manufacturer:

Other Similar products are found below :

[IRFD120](#) [JANTX2N5237](#) [BUK455-60A/B](#) [MIC4420CM-TR](#) [VN1206L](#) [NDP4060](#) [SI4482DY](#) [IPS70R2K0CEAKMA1](#) [SQD23N06-31L-GE3](#)
[TK16J60W,S1VQ\(O](#) [2SK2614\(TE16L1,Q\)](#) [DMN1017UCP3-7](#) [DMN1053UCP4-7](#) [SQJ469EP-T1-GE3](#) [NTE2384](#) [DMC2700UDMQ-7](#)
[DMN2080UCB4-7](#) [DMN61D9UWQ-13](#) [US6M2GTR](#) [DMN31D5UDJ-7](#) [DMP22D4UFO-7B](#) [DMN1006UCA6-7](#) [DMN16M9UCA6-7](#)
[STF5N65M6](#) [IRF40H233XTMA1](#) [STU5N65M6](#) [DMN6022SSD-13](#) [DMN13M9UCA6-7](#) [DMTH10H4M6SPS-13](#) [DMN2990UFB-7B](#)
[IPB80P04P405ATMA2](#) [2N7002W-G](#) [MCAC30N06Y-TP](#) [MCQ7328-TP](#) [NTMC083NP10M5L](#) [BXP7N65D](#) [BXP4N65F](#) [AOL1454G](#)
[WMJ80N60C4](#) [BXP2N20L](#) [BXP2N65D](#) [BXT1150N10J](#) [BXT1700P06M](#) [TSM60NB380CP](#) [ROG](#) [RQ7L055BGTGR](#) [DMNH15H110SK3-13](#)
[SLF10N65ABV2](#) [BSO203SP](#) [BSO211P](#) [IPA60R230P6](#)