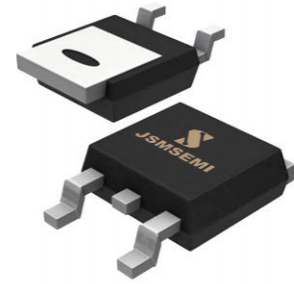


Description:

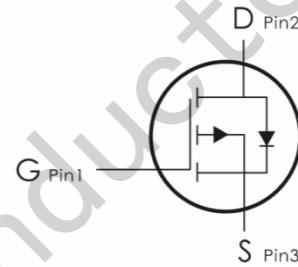
This P-Channel MOSFET uses advanced trench technology and design to provide excellent $R_{DS(on)}$ with low gate charge.

It can be used in a wide variety of applications.



Features:

- 1) $V_{DS}=-60V, I_D=-30A, R_{DS(ON)}<35m\Omega @ V_{GS}=-10V$
- 2) Low gate charge.
- 3) Green device available.
- 4) Advanced high cell density trench technology for ultra $R_{DS(ON)}$.
- 5) Excellent package for good heat dissipation.



Absolute Maximum Ratings: ($T_C=25^\circ C$ unless otherwise noted)

Symbol	Parameter	Ratings	Units
V_{DS}	Drain-Source Voltage	-60	V
V_{GS}	Gate-Source Voltage	± 20	V
I_D	Continuous Drain Current	-30	A
	Continuous Drain Current-TC=100°C	-19	
	Pulsed Drain Current ¹	---	
E_{AS}	Single Pulse Avalanche Energy	225	mJ
P_D	Power Dissipation	50	W
T_J, T_{STG}	Operating and Storage Junction Temperature Range	-55 to +175	°C

Thermal Characteristics:

Symbol	Parameter	Max	Units
$R_{\theta JC}$	Thermal Resistance, Junction to Case	3	°C/W
$R_{\theta JA}$	Thermal Resistance, Junction to Ambient	42	

Electrical Characteristics: ($T_C=25^\circ\text{C}$ unless otherwise noted)

Symbol	Parameter	Conditions	Min	Typ	Max	Units
Off Characteristics						
BV_{DSS}	Drain-Source Breakdown Voltage	$V_{GS}=0V, I_D=250\ \mu\text{A}$	-60	---	---	V
I_{DSS}	Zero Gate Voltage Drain Current	$V_{GS}=0V, V_{DS}=-60V$	---	---	-1	μA
I_{GSS}	Gate-Source Leakage Current	$V_{GS}=\pm 20V, V_{DS}=0A$	---	---	± 100	nA
On Characteristics						
$V_{GS(th)}$	GATE-Source Threshold Voltage	$V_{GS}=V_{DS}, I_D=250\ \mu\text{A}$	-1	-1.8	-2.5	V
$R_{DS(ON)}$	Drain-Source On Resistance ^②	$V_{GS}=-10V, I_D=-15A$	---	26	35	m Ω
		$V_{GS}=-4.5V, I_D=-10A$	---	32	40	
G_{FS}	Forward Transconductance	$V_{DS}=-10V, I_D=-15A$	---	---	---	S
Dynamic Characteristics						
C_{iss}	Input Capacitance	$V_{DS}=-30V, V_{GS}=0V, f=1\text{MHz}$	---	2535	---	pF
C_{oss}	Output Capacitance		---	130	---	
C_{rss}	Reverse Transfer Capacitance		---	75	---	
Switching Characteristics						
$t_{d(on)}$	Turn-On Delay Time	$V_{DD}=-30V, I_D=-10A,$ $R_{GEN}=6.8\ \Omega, V_{GS}=-10V$	---	14	---	ns
t_r	Rise Time		---	18	---	ns
$t_{d(off)}$	Turn-Off Delay Time		---	42	---	ns
t_f	Fall Time		---	15	---	ns
Q_g	Total Gate Charge	$V_{GS}=-10V, V_{DS}=-30V,$ $I_D=-10A$	---	46	---	nC
Q_{gs}	Gate-Source Charge		---	11	---	nC
Q_{gd}	Gate-Drain "Miller" Charge		---	10	---	nC
Drain-Source Diode Characteristics						
V_{SD}	Source-Drain Diode Forward Voltage	$V_{GS}=0V, I_S=-15A, T_J=25^\circ\text{C}$	---	-0.88	-1.2	V

t_{rr}	Reverse Recovery Time	$I_{sd} = -20A, V_{GS} = 0V$	---	28	---	ns
Q_{rr}	Reverse Recovery Charge	$dI/dt = -500A/\mu s$	---	165	---	nc

Notes:

1. Repetitive rating; pulse width limited by max. junction temperature.
2. Pulse width $\leq 300 \mu s$; duty cycle $\leq 2\%$.
3. Limited by T_{Jmax} , starting $T_J = 25^\circ C$, $L = 0.5mH, R_G = 25 \Omega$, $I_{AS} = -32A, V_{GS} = -10V$. Part not recommended for use above this value

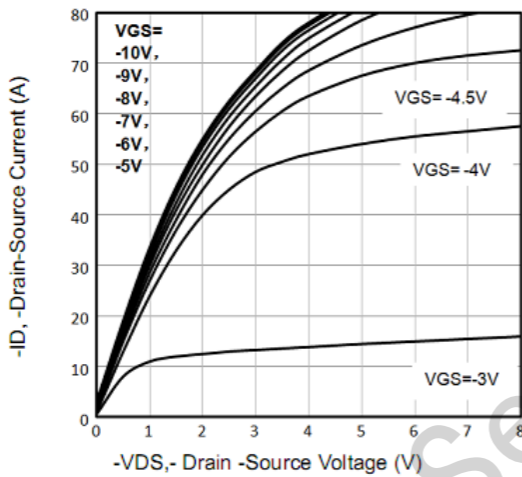
Typical Characteristics: ($T_c = 25^\circ C$ unless otherwise noted)


Fig1. Typical Output Characteristics

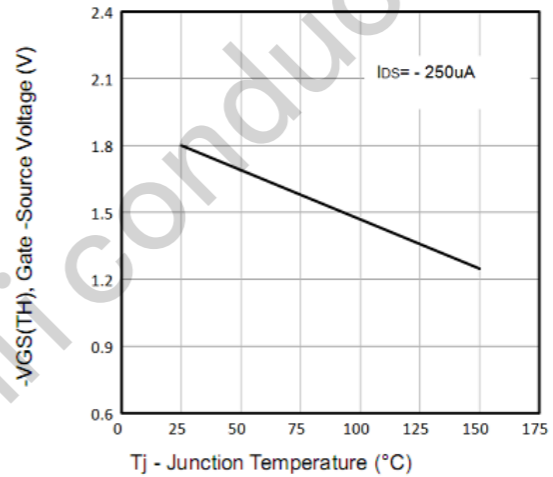
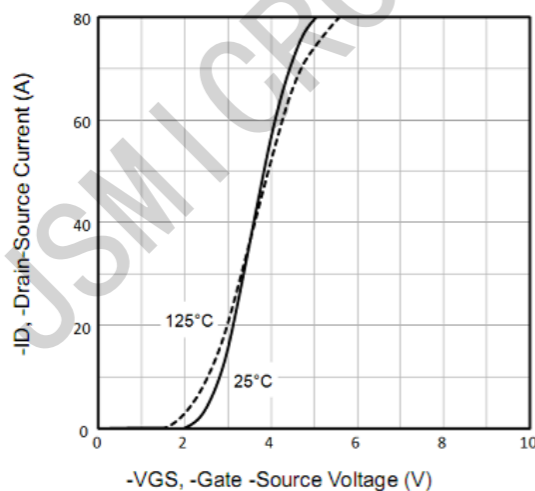
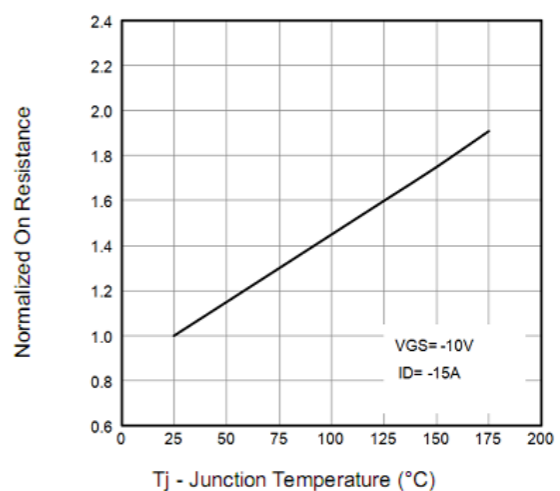

 Fig2. $-V_{GS(TH)}$ Gate -Source Voltage Vs. T_j


Fig3. Typical Transfer Characteristics


 Fig4. Normalized On-Resistance Vs. T_j

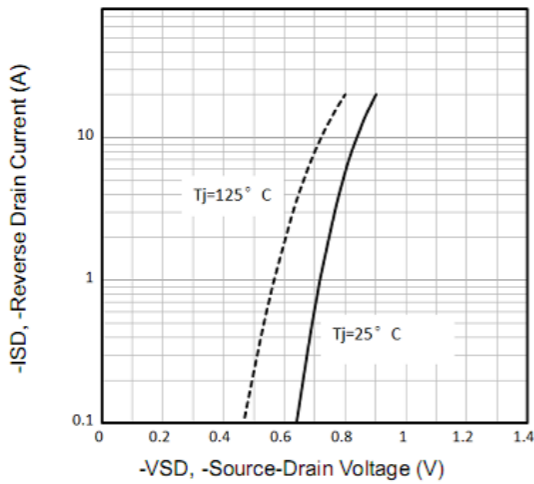


Fig5. Typical Source-Drain Diode Forward Voltage

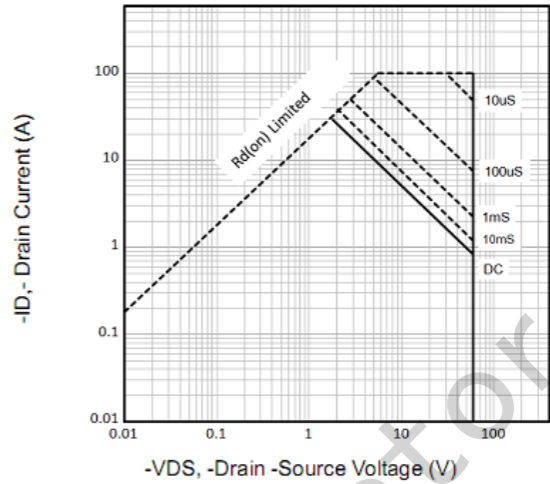


Fig6. Maximum Safe Operating Area

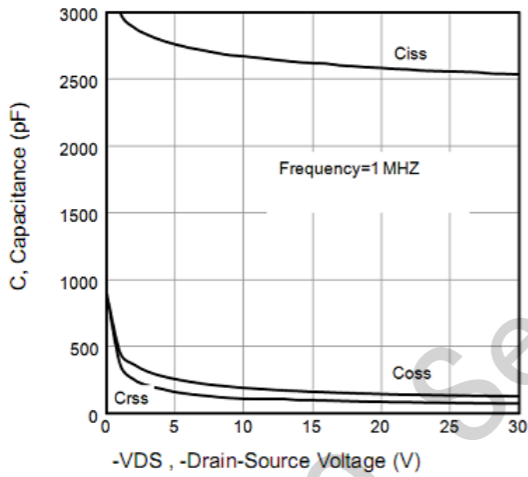


Fig7. Typical Capacitance Vs. Drain-Source Voltage

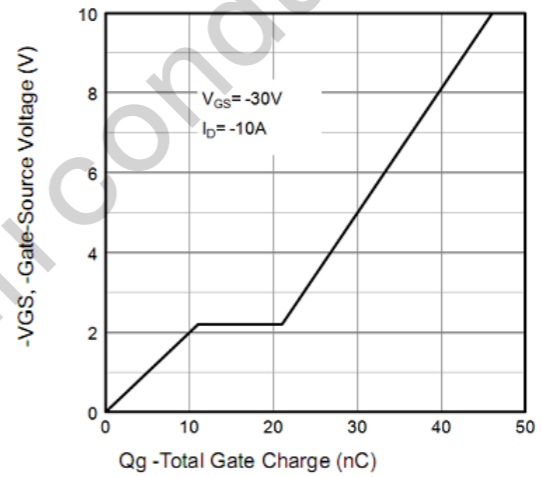


Fig8. Typical Gate Charge Vs. Gate-Source Voltage

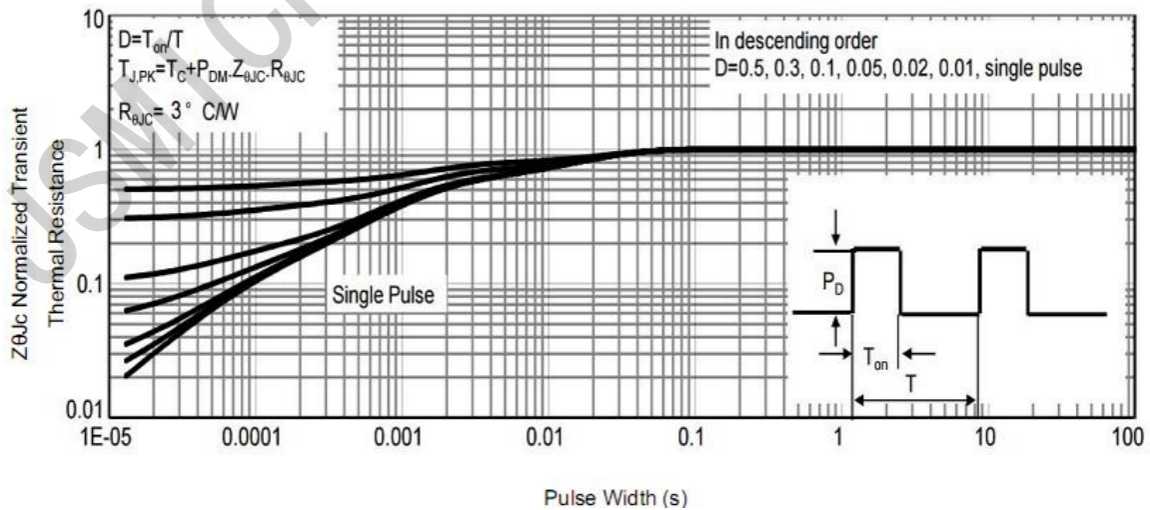


Fig9. Normalized Maximum Transient Thermal Impedance

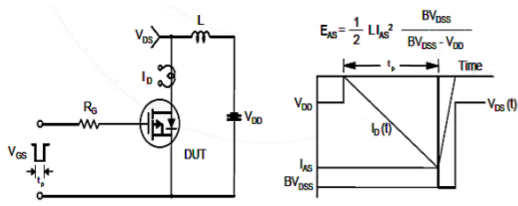


Fig10. Unclamped Inductive Test Circuit and Waveforms

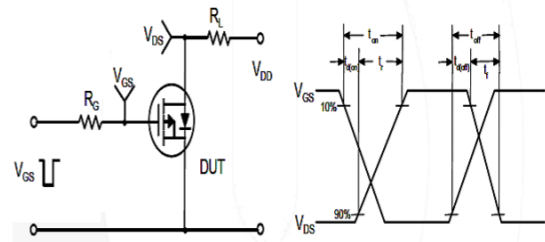
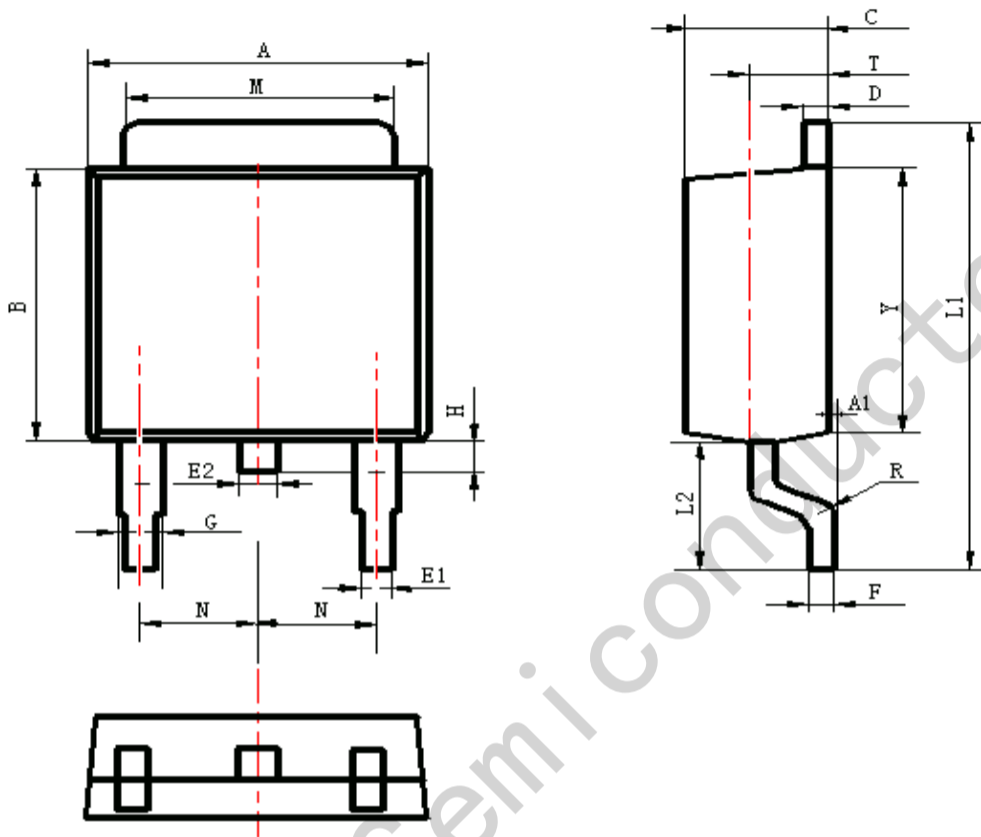


Fig11. Switching Time Test Circuit and waveforms

JSMICRO Semiconductor

Package Information

TO-252



Symbol	Dimensions In Millimeters		Dimensions In Inches	
	Min.	Max.	Min.	Max.
A	6.30	6.90	0.248	0.272
A1	0.00	0.16	0.000	0.006
B	5.70	6.30	0.224	0.248
C	2.10	2.50	0.083	0.098
D	0.30	0.70	0.012	0.028
E1	0.60	0.90	0.024	0.035
E2	0.70	1.00	0.028	0.039
F	0.30	0.60	0.012	0.024
G	0.70	1.20	0.028	0.047
L1	9.60	10.50	0.378	0.413
L2	2.70	3.10	0.106	0.122
H	0.40	1.00	0.016	0.039
M	5.10	5.50	0.201	0.217
N	2.09	2.49	0.082	0.098
R	0.30		0.012	
T	1.40	1.60	0.055	0.063
Y	5.10	6.30	0.201	0.248

X-ON Electronics

Largest Supplier of Electrical and Electronic Components

Click to view similar products for [MOSFET](#) category:

Click to view products by [JSMSEMI](#) manufacturer:

Other Similar products are found below :

[IRFD120](#) [JANTX2N5237](#) [BUK455-60A/B](#) [MIC4420CM-TR](#) [VN1206L](#) [NDP4060](#) [SI4482DY](#) [IPS70R2K0CEAKMA1](#) [SQD23N06-31L-GE3](#)
[TK16J60W,S1VQ\(O](#) [2SK2614\(TE16L1,Q\)](#) [DMN1017UCP3-7](#) [DMN1053UCP4-7](#) [SQJ469EP-T1-GE3](#) [NTE2384](#) [DMC2700UDMQ-7](#)
[DMN2080UCB4-7](#) [DMN61D9UWQ-13](#) [US6M2GTR](#) [DMN31D5UDJ-7](#) [DMP22D4UFO-7B](#) [DMN1006UCA6-7](#) [DMN16M9UCA6-7](#)
[STF5N65M6](#) [IRF40H233XTMA1](#) [STU5N65M6](#) [DMN6022SSD-13](#) [DMN13M9UCA6-7](#) [DMTH10H4M6SPS-13](#) [DMN2990UFB-7B](#)
[IPB80P04P405ATMA2](#) [2N7002W-G](#) [MCAC30N06Y-TP](#) [MCQ7328-TP](#) [BXP7N65D](#) [BXP4N65F](#) [AOL1454G](#) [WMJ80N60C4](#) [BXP2N20L](#)
[BXP2N65D](#) [BXT1150N10J](#) [BXT1700P06M](#) [TSM60NB380CP ROG](#) [RQ7L055BGTCR](#) [DMNH15H110SK3-13](#) [SLF10N65ABV2](#)
[BSO203SP](#) [BSO211P](#) [IPA60R230P6](#) [IPA60R460CE](#)