

FEATURES

- 600 Watts Pulse capability
- Excellent clamping capability
- Low incremental surge resistance
- Fast response time
- High temperature soldering guaranteed: 260°C/10 seconds at terminals
- Component in accordance to RoHS 2011/65/EU



MECHANICAL DATA

- Case: JEDEC SMB(DO-214AA) molded plastic body
- Terminals: Solder Plated
- Polarity: By cathode band denotes uni-directional device, none cathode band denotes bi-directional device.

DEVICES FOR BIDIRECTIONAL APPLICATIONS

1. For bi-directional use C suffix for Types .
2. Electrical characteristics apply in both directions.

MAXIMUM RATINGS AND ELECTRICAL CHARACTERISTICS

(Rating at 25°C ambient temperature unless otherwise specified)

	Symbols	Value	Units
Peak Pulse Power Dissipation at on 10/1000µs Waveform (Note 1, 2)	PPK	600	Watts
Peak forward surge current, 8.3ms single half sine-wave superimposed on rated load (JEDEC method) (Note 2)	IFSM	100	Amps
Operating junction and storage temperature range	TJ, TSTG	-55 to 150	°C

Note: 1. Non repetitive current pulse and derated above TA=25°C

2. Measured on 8.3ms single half sine-wave or equivalent square wave, duty cycle=4 pulses per minute maximum

Part number		Reverse Standoff Voltage VRWM (Volts)	Breakdown Voltage VBR (Volts)		Test Current (mA)	Maximum Clamping Voltage VC@Ipp (Volts)	Maximum Peak Pulse Current Ipp(A)	Maximum Reverse Leakage IR@VRWM (μA)
UNI	BI		MIN	MAX				
SMBJ5.0A	SMBJ5.0CA	5	6.40	7.07	10	9.6	65.2	500
SMBJ6.0A	SMBJ6.0CA	6	6.67	7.37	10	10.3	58.3	300
SMBJ6.5A	SMBJ6.5CA	6.5	7.22	7.98	10	11.2	53.6	200
SMBJ7.0A	SMBJ7.0CA	7	7.78	8.60	10	12.0	50.0	100
SMBJ7.5A	SMBJ7.5CA	7.5	8.33	9.21	1	12.9	46.6	50
SMBJ8.0A	SMBJ8.0CA	8	8.89	9.83	1	13.6	44.2	50
SMBJ8.5A	SMBJ8.5CA	8.5	9.44	10.40	1	14.4	41.7	30
SMBJ9.0A	SMBJ9.0CA	9	10.00	11.10	1	15.4	39.0	30
SMBJ10A	SMBJ10CA	10	11.10	12.30	1	17.0	35.3	3
SMBJ11A	SMBJ11CA	11	12.20	13.50	1	18.2	33.0	1
SMBJ12A	SMBJ12CA	12	13.30	14.70	1	19.9	30.2	1
SMBJ13A	SMBJ13CA	13	14.40	15.90	1	21.5	28.0	1
SMBJ14A	SMBJ14CA	14	15.60	17.20	1	23.2	25.9	1
SMBJ15A	SMBJ15CA	15	16.70	18.50	1	24.4	24.6	1
SMBJ16A	SMBJ16CA	16	17.80	19.70	1	26.0	23.1	1
SMBJ17A	SMBJ17CA	17	18.90	20.90	1	27.6	21.8	1
SMBJ18A	SMBJ18CA	18	20.00	22.10	1	29.2	20.6	1
SMBJ20A	SMBJ20CA	20	22.20	24.50	1	32.4	18.6	1
SMBJ22A	SMBJ22CA	22	24.40	26.90	1	35.5	16.9	1
SMBJ24A	SMBJ24CA	24	26.70	29.50	1	38.9	15.5	1
SMBJ26A	SMBJ26CA	26	28.90	31.90	1	42.1	14.3	1
SMBJ28A	SMBJ28CA	28	31.10	34.40	1	45.4	13.3	1
SMBJ30A	SMBJ30CA	30	33.30	36.80	1	48.4	12.4	1
SMBJ33A	SMBJ33CA	33	36.70	40.60	1	53.3	11.3	1
SMBJ36A	SMBJ36CA	36	40.00	44.20	1	58.1	10.4	1
SMBJ40A	SMBJ40CA	40	44.40	49.10	1	64.5	9.3	1
SMBJ43A	SMBJ43CA	43	47.80	52.80	1	69.4	8.7	1
SMBJ45A	SMBJ45CA	45	50.00	55.30	1	72.7	8.3	1
SMBJ48A	SMBJ48CA	48	53.30	58.90	1	77.4	7.8	1
SMBJ51A	SMBJ51CA	51	56.70	62.70	1	82.4	7.3	1

SMBJ54A	SMBJ54CA	54	60.00	66.30	1	87.1	6.9	1
SMBJ58A	SMBJ58CA	58	64.40	71.20	1	93.6	6.5	1
SMBJ60A	SMBJ60CA	60	66.70	73.70	1	96.8	6.2	1
SMBJ64A	SMBJ64CA	64	71.10	78.60	1	103.0	5.9	1
SMBJ70A	SMBJ70CA	70	77.80	86.00	1	113.0	5.3	1
SMBJ75A	SMBJ75CA	75	83.30	92.10	1	121.0	5.0	1
SMBJ78A	SMBJ78CA	78	86.70	95.80	1	126.0	4.8	1
SMBJ85A	SMBJ85CA	85	94.40	104.00	1	137.0	4.4	1
SMBJ90A	SMBJ90CA	90	100.0	111.00	1	146.0	4.1	1
SMBJ100A	SMBJ100CA	100	111.0	123.00	1	162.0	3.7	1
SMBJ110A	SMBJ110CA	110	122.0	135.00	1	177.0	3.4	1
SMBJ120A	SMBJ120CA	120	133.0	147.00	1	193.0	3.1	1
SMBJ130A	SMBJ130CA	130	144.0	159.00	1	209.0	2.9	1
SMBJ150A	SMBJ150CA	150	167.0	185.00	1	243.0	2.5	1
SMBJ160A	SMBJ160CA	160	178.0	197.00	1	259.0	2.3	1
SMBJ170A	SMBJ170CA	170	189.0	209.00	1	275.0	2.2	1
SMBJ180A	SMBJ180CA	180	201.0	222.00	1	292.0	2.1	1
SMBJ190A	SMBJ190CA	190	211.0	233.00	1	306.0	2.0	1
SMBJ200A	SMBJ200CA	200	224.0	247.00	1	324.0	1.9	1
SMBJ210A	SMBJ210CA	210	233.0	258.00	1	324.0	1.9	1
SMBJ220A	SMBJ220CA	220	246.0	272.00	1	356.0	1.7	1
SMBJ250A	SMBJ250CA	250	279.0	309.00	1	405.0	1.5	1
SMBJ300A	SMBJ300CA	300	335.0	371.00	1	486.0	1.3	1
SMBJ350A	SMBJ350CA	350	391.0	432.00	1	567.0	1.1	1
SMBJ400A	SMBJ400CA	400	447.0	494.00	1	648.0	0.9	1
SMBJ440A	SMBJ440CA	440	489.0	543.00	1	710.0	0.8	1

For Bi-directional type having VRWM of 10 Volts and less, the IR limit is double

1.A transient suppressor is normally selected according to the working peak reverse voltage (VRWM), which should be equal to or greater than the DC or continuous peak operating voltage level.

2.VBR measured at pulse test current IT at an ambient temperature of 25°C.

3.Surge current waveform per Figure 2 and derate per Figure 3

FIG. 1 PEAK PULSE POWER CURVE

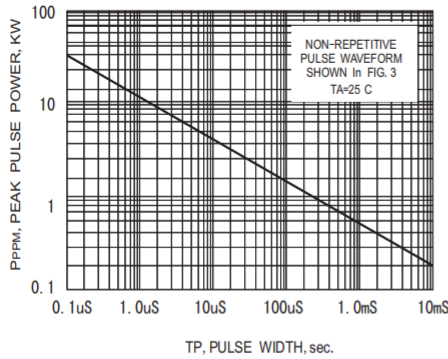

FIG. 2-PULSE DERATING CURVE

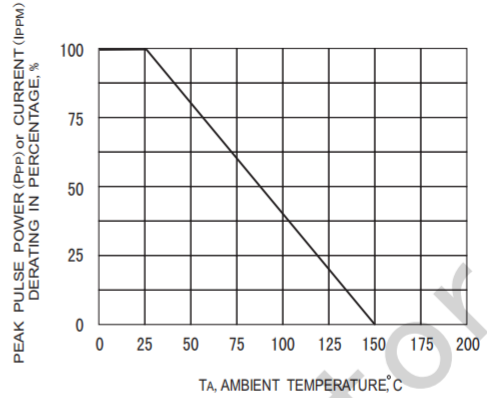

FIG. 3-PULSE WAVEFORM

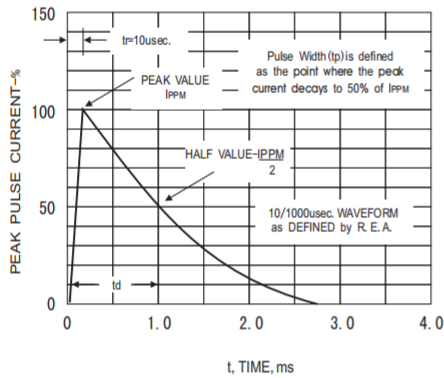

FIG. 4-MAXIMUM NON-REPETITIVE PEAK FORWARD SURGE CURRENT

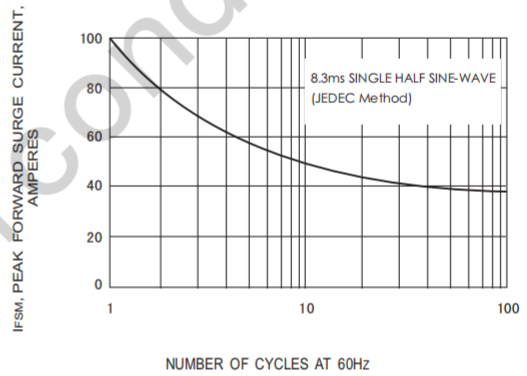

FIG. 5-Steady State Power Derating Curve

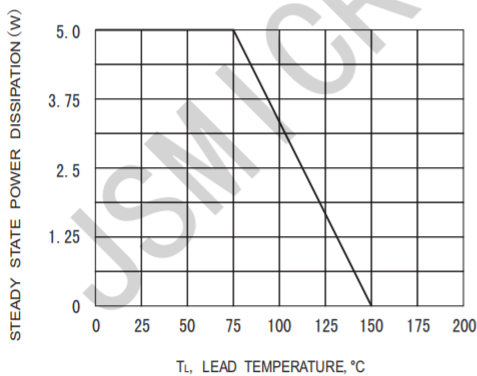
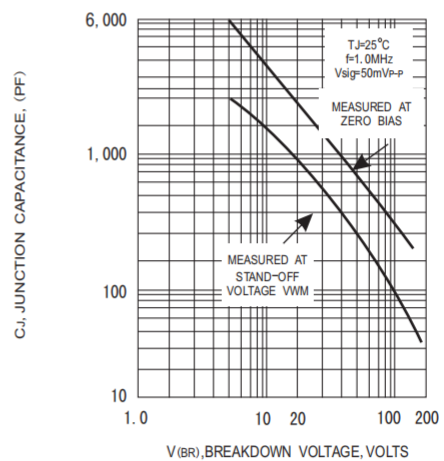

FIG. 6-TYPICAL JUNCTION CAPACITANCE



Package Information

SMB

Plastic surface mounted package; 2 leads

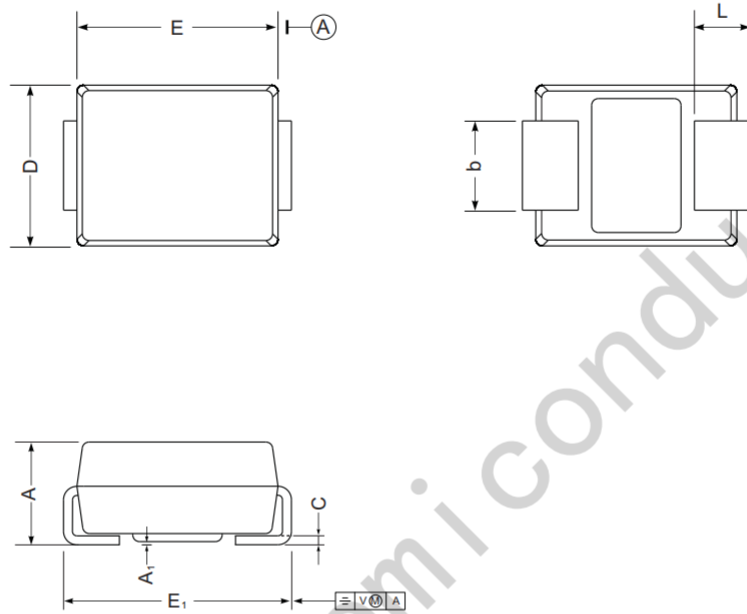

SMB mechanical data

UNIT		A	E	D	E ₁	A ₁	L	C	b
mm	max	2.44	4.70	3.94	5.59	0.20	1.5	0.305	2.11
	min	2.13	4.06	3.3	5.08	0.05	0.8	0.152	1.91
mil	max	96	185	155	220	7.9	59	12	83
	min	84	160	130	200	2.0	32	6	75

The recommended mounting pad size

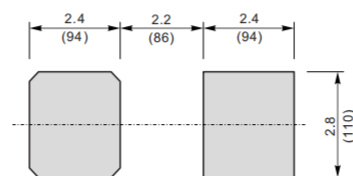

Unit: $\frac{\text{mm}}{\text{(mil)}}$

X-ON Electronics

Largest Supplier of Electrical and Electronic Components

Click to view similar products for [ESD Suppressors / TVS Diodes](#) category:

Click to view products by [JSMSEMI](#) manufacturer:

Other Similar products are found below :

[60KS200C](#) [D18V0L1B2LP-7B](#) [D5V0F4U5P5-7](#) [NTE4902](#) [P4KE27CA](#) [P6KE11CA](#) [P6KE8.2A](#) [JANTX1N6053A](#) [SA60CA](#) [SA64CA](#)
[SMBJ12CATR](#) [SMBJ33CATR](#) [SMBJ6.5A](#) [SMBJ8.0A](#) [ESD101-B1-02ELS E6327](#) [ESD112-B1-02EL E6327](#) [ESD7451N2T5G](#) [19180-510](#)
[CPDT-5V0USP-HF](#) [3.0SMCJ33CA-F](#) [3.0SMCJ36A-F](#) [HSPC16701B02TP](#) [JANTX1N6126A](#) [D3V3Q1B2DLP3-7](#) [D55V0M1B2WS-7](#)
[SCM1293A-04SO](#) [ESD200-B1-CSP0201 E6327](#) [SM12-7](#) [CEN955 W/DATA](#) [VESD12A1A-HD1-GS08](#) [CPDQC5V0-HF](#) [D1213A-01LP4-7B](#)
[ESD101-B1-02EL E6327](#) [AOZ8808DI-03](#) [5KP15A](#) [5KP48A](#) [5KP90A](#) [ESD3V3D7-TP](#) [15KPA36A-LF](#) [P4KE56CA](#) [P4KE68A](#) [P6KE120A](#)
[P6KE13CA](#) [P6KE43CA](#) [P6KE6.8CA](#) [P6KE8.2](#) [P6SMBJ20CA](#) [JANTX1N6072A](#) [SR2835ESKG](#) [SA90CA](#)