

# APPLICATION TOOLING

## Crimping tools and machines

The arrow mark indicates the press that is applicable to the applicator.

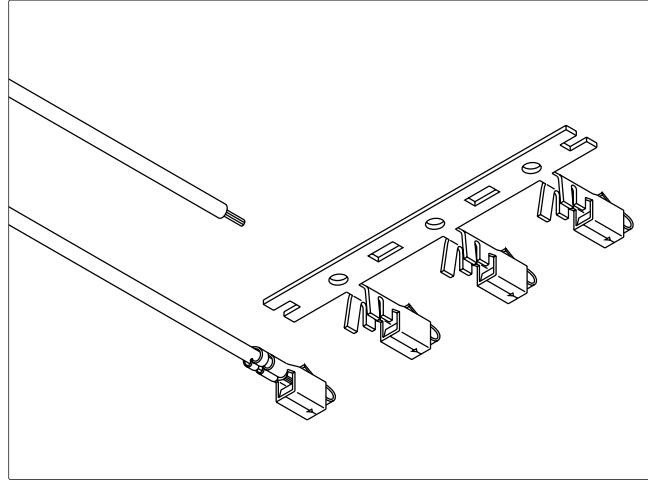

**Semi-automatic press**

Semi-automatic crimping machines (presses) contact a wire to a chain terminal each time a footswitch is pressed.

**AP-K2N**

- Dimensions: (W×L×H)280×480×505 mm
- Weight: Approx. 90 kg(198 lb)
- Power source: 100 VAC, Single-phase 50/60 Hz
- Pressure output: 14.7 kN(1,500 kg(3307 lb))
- Dies: Applicator replacement

**Strip-crimp applicator for side feeding terminals**

**MKS-SC**

**Crimping applicator for side-feeding terminals**

**MKS-L**

**Crimping applicator for end-feeding terminals**

**MK-L**

**Crimping applicator for end-feeding flag terminals**

**MKF-L**

Note: Contact JST for wire range.

Table with 10 columns: Part No., Description, Terminal, Material, Contact, etc. Rows include models like JKS-SP2, YRS series, J-Sp1, LFO, MD-SP, RA-SC, RF-SC, RPJ-SP, SAA, SAGH, SAN, SBH, SBHL, SBHM, SBHS, SBHSM, SBHT, SCS, SCSH.

Technical section for crimping tools. Includes 'Hand tools' and 'Hand tools for loose piece terminals' categories. Lists YRS, YC, YRM, YRF, YRK, YRK-EX series with dimensions and images. Includes 'Crimping tools' section with notes on manual tool usage and JST hand tools.

# Hand tools

## Crimping tools

Terminals and parts model number in alphabetical order	Hand tools			Hand tools			Hand tools			Insertion tool
	for chain terminals	for loose piece terminals	for loose piece terminals	WC & JUC series	JUK's Hand Tools	Terminal in loose form model No.	Extraction tool	Extraction and Insertion tools		
	YRS series	YRM series	YRF series	YRK · YRK-EX series						
SCSN-41T-P2.3	-	-	-	-	-	-	EJ-CSN	-	-	
SCZH-002T-P0.5	YRS-492	-	-	-	-	-	-	-	-	
SDACP-002T-M0.9	YRS-1530	-	-	-	-	-	-	-	-	
	YRS-1531	-	-	-	-	-	-	-	-	
SDF-01T-1.0A	-	YC-045	-	-	-	-	LDF-01T-1.0A	-	-	
SDF-01T-1.3AS	-	-	-	-	-	-	LDF-01T-1.3AS	-	-	
SDN-21T-P1.5	-	YC-600R	-	-	-	-	BDN-21T-P1.5	-	-	
SDY-01T-P1.6ASV	-	YC-525R	-	-	-	-	BDY-01T-P1.6ASV	-	SLJ-1.4	
SEH-001T-P0.6	YRS-260	YC-260R	-	-	WC-260	-	BEH-001T-P0.6	-	EJ-PH	
SEH-001T-P0.6L	-	-	-	-	-	-	-	-	EJ-PH	
SEH-002T-P0.6L	-	-	-	-	-	-	-	-	EJ-PH	
SEH-003T-P0.6L	-	-	-	-	-	-	-	-	EJ-PH	
SF1F-01GC-P0.6	-	-	-	YRK-1230	-	-	-	-	-	
SF1M-01GC-M0.6A	-	-	-	-	-	-	-	-	-	
SF1F-002T(GC)-P0.6	-	-	-	YRK-1220	-	-	-	-	EJ-JFAJ1100	
SF1M-002T(GC)-M0.6A	-	-	-	-	-	-	-	-	EJ-JFAJ1100	
SF3F-002(*)-P2.0	-	-	YRF-882	YRK-8821	-	BF3F-002(*)-P2.0	BF3M-002(*)-M2.0N	-	EJ-JFAJ3	
SF3F-01(*)-P2.0	-	-	YRF-881	YRK-8811	-	BF3F-01(*)-P2.0	BF3M-01(*)-M2.0N	-	EJ-JFAJ3	
SF3F-41(*)-P2.0	-	-	YRF-880	YRK-8801	-	LF3F-41(*)-P2.0	LF3M-41(*)-M2.0N	-	EJ-JFAJ3	
SF3F-71(*)-P2.0	-	YRF-1070	-	YRK-1071	-	BF3F-71(*)-P2.0	BF3M-71(*)-M2.0N	-	EJ-JFAJ3	
SFO-41(T)-187N(-8)	YC-271	-	-	-	-	LFO-41(T)-187N	-	-	-	
SFO-61(T)-250A	YC-270	-	-	-	-	LFO-61(T)-250A	-	-	-	
SFPS-61T-250	YC-272	-	-	-	-	LFP-61(T)-250	-	-	-	
SFT-61T-250N	YC-510	-	-	-	-	LFT-61T-250N	-	-	-	
SGF-41(T)-4	YC-055	-	-	-	-	LGf-41(T)-4	-	-	-	
SGF-51(T)-5	YC-065	-	-	-	-	LGf-51(T)-5	-	-	-	
	-	-	-	-	-	LGf-51(T)-5A	-	-	-	
SGHD-002GA-P0.2	YRS-1590	-	-	-	-	-	-	-	-	
SGM-51T-5	-	YC-056	-	-	-	LGm-51T-5	-	-	-	
SGVH-002T-P0.2	YRS-1590	-	-	-	-	-	-	-	-	
SHCM-A03T-P025	YRS-960	-	-	-	WC-SHCM-A03	-	-	-	-	
SHF-001T-0.8BS	YRS-122	YC-122R	-	-	WC-122	BHF-001T-0.8BS	EJ-SMP (Note1)	-	-	
SHF-002T-0.8BS	YRS-300	-	-	-	-	-	EJ-SMP (Note1)	-	-	
SHIF-01T-P0.5	YC-985R	-	-	-	-	-	EJ-HILP	-	-	
SHIF-21T-P0.5	YC-995R	-	-	-	-	-	EJ-HILP	-	-	
SHIM-01T-P0.5	YC-985R	-	-	-	-	-	EJ-HILR	-	-	
SHIM-21T-P0.5	YC-995R	-	-	-	-	-	EJ-HILR	-	-	
SHR-001T-P0.6	YRS-580	YC-580R	-	-	-	BHR-001T-P0.6	-	-	-	
SHYF-21T-M0.5	-	-	-	-	-	-	EJ-BNI	-	-	
SHYF-41T-M0.5	-	-	-	-	-	-	EJ-BNI	-	-	
SIM-01(T)-110A	YC-054	-	-	-	-	LIM-01(T)-110A	-	-	-	
SIM-1.0-250D/N	-	-	-	-	JUCS-IM	-	-	-	-	
SIM-2.5-250D/N	-	-	-	-	JUCS-IM	-	-	-	-	
SIM-41(T)-110B	YC-067	-	-	-	-	LIM-41(T)-110B	-	-	-	
SIM-51(T)-250N	YC-321	-	-	-	-	LIM-51(T)-250N	-	-	-	

Note 1: Please use EJ-SMP as an extraction tool when using the combination with SM connector 18-circuit housing.

Note 2: Contact JST for wire range.

Note: Contact JST for wire range.

Terminals and parts model number in alphabetical order	Hand tools				Hand tools				Insertion tool
	for chain terminals		for loose piece terminals		for loose piece terminals		JUK's Hand Tools		
	YRS series	YC series	YRM series	YRF series	YRK · YRK-EX series	WC & JUC series	Terminal in loose form	Extraction tool	
SIN-001T-1.2	YRS-034	-	-	-	-	-	-	-	-
SIN-002T-1.0S	YRS-035	-	-	-	-	-	-	-	-
SIN-01T-1.2	-	YC-340R	-	-	-	-	LIN-01T-1.2	-	-
SIN-01T-1.8	-	-	-	-	-	-	LIN-01T-1.8	-	-
SIN-01T-1.8N	-	YC-032	-	-	-	-	LIN-01T-1.8N	-	-
SIN-21T-1.8	-	YC-350	-	-	-	-	LIN-21T-1.8	-	-
SIN-21T-1.8S	-	YC-570	-	-	-	-	LIN-21T-1.8S	-	-
SIN-61T-2.6S	-	YC-560	-	-	-	-	LIN-61T-2.6S	-	-
SIN-81T-3.6S	-	YC-940	-	-	-	-	LIN-81T-3.6S	-	-
SIN-91T-4.7S	-	-	-	-	YRK-1630	-	-	-	-
SJ2F-002GF-P1.0	YRS-8851	-	-	-	YRK-8851	-	-	-	EJ-JFAJ2N
SJ2F-01GF-P1.0	YRS-8861	-	-	-	YRK-8861	-	-	-	EJ-JFAJ2N
SJ2M-01GF-M1.0S	-	-	-	-	-	-	-	-	-
SJ2M-21GF-M1.0N	-	-	-	-	YRK-1120	-	LJ2F-21GF-P1.0	-	EJ-JFAJ2N
SJ3F-002GF-P1.8	-	-	-	-	YRF-882	-	-	-	-
SJ3F-01GF-P1.8	-	-	-	-	YRF-881	-	-	-	-
SJ3F-41GF-P1.8	-	-	-	-	YRF-880	-	-	-	-
SJ4F-71GF-M3.0	-	-	-	-	YRF-1130	-	BJ4F-71GF-M3.0	-	EJ-JFAJ4
SJ4F-81GF-M3.0	-	-	-	-	YRF-1370	-	BJ4F-81GF-M3.0	-	EJ-JFAJ4
SJ5F-71GF-M6.5	-	-	-	-	YRF-888	-	BJ5F-71GF-M6.5	-	EJ-JFAJ5
SJ5F-81GF-M6.5	-	-	-	-	YRF-889	-	LJ5F-81GF-M6.5	-	EJ-JFAJ5
SJ5M-81GF-M6.5	-	-	-	-	-	-	LJ5M-81GF-M6.5	-	EJ-JFAJ5
SJ5F-91GF-M6.5	-	-	-	-	-	-	LJ5F-91GF-M6.5	-	EJ-JFAJ5
SJ5M-91GF-M6.5	-	-	-	-	-	-	LJ5M-91GF-M6.5	-	EJ-JFAJ5
SJFPS-81T-M1.0	-	-	-	-	YRF-1610	-	-	-	-
SJN-001PT-0.9	YRS-1181	-	-	-	-	-	-	-	-
SJN-002PT-0.9	YRS-036	-	-	-	-	-	-	-	-
SJWPSR-21T-P1.0	-	-	-	-	-	-	-	-	-
SJWPST-21T-M1.0N	-	-	-	-	-	-	-	-	EJ-JWPS-RT
SLC-21T-2.0	-	YC-310	-	-	-	WC-310	LLC-21T-2.0	-	-
SLC-001T-P2.0	-	-	-	-	-	-	-	-	EJ-LCL
SLC-02T-P2.0	-	-	-	-	-	-	-	-	EJ-LCL
SLE-01T-P1.3E	-	-	-	-	-	WC-202	LLF/M-01T-P1.3E	-	LEJ-13
SLE-41T-P1.3E	-	-	-	-	-	WC-203	LLF/M-41T-P1.3E	-	LEJ-13
SMF-01T-1.0	-	YC-081	-	-	-	-	LMF-01T-1.0	-	-
SMF-01T-1.3	-	YC-082	-	-	-	-	LMF-01T-1.3	-	-
SMM-003T-P0.5	YRS-800	-	-	-	-	WC-800	-	-	-
SMR-001T-0.6	YRS-580	YC-580R	-	-	-	-	BMR-001T-0.6	-	-
SOM-21(T)-187	-	YC-680	-	-	-	-	LOM-21(T)-187	-	-
SOM-51(T)-250	-	YC-066	-	-	-	WC-066	LOM-51(T)-250	-	-
SOTZP-002GD-P0.18	-	-	-	-	-	-	-	-	EJ-OTZS

Terminals and parts model number in alphabetical order	Hand tools			Hand tools				Hand tools			Insertion tool
	for chain terminals			for loose piece terminals				for loose piece terminals			
YRS series	YC series	YRM series	YRF series	YRK · YRK-EX series	WC & JUC series	JUC's Hand Tools	Terminal in loose form model No.	Extraction tool	Extraction and Insertion tools		
SPA-001T-P0.5	YC-610R	YC-611R	YC-610R				BPA-001T-P0.5	EJ-PH			
SPAL-001T-P0.5	YC-610R	YC-611R	YC-610R				BPAL-001T-P0.5	EJ-PAL			
SPAL-002T-P0.5		YRS-1340						EJ-PAL			
SPB-1.0-250N-S					JUCS-PB	JUCS-PB					
SPB-2.5-250N-S					JUCS-PB	JUCS-PB					
SPBD-001T-P0.5	YC-610R										
SPBD-002T-P0.5	YC-611R										
SPF-01T-2.5C	YC-043R						LPF-01T-2.5C				
SPH-001T-P0.5L	YRS-245										
SPH-002T-P0.5L	YRS-241										
SPH-002T-P0.5S	YRS-240	YRM-240			WC-240		BPH-002T-P0.5S	EJ-PH			
SPH-004T-P0.5S	YRS-243										
SPHD-001T-P0.5	YC-610R				WC-610		BPHD-001T-P0.5	EJ-PHD-RB			
SPHD-002T-P0.5	YC-611R				WC-620		BPHD-002T-P0.5	EJ-PHD-RB			
SPID-001T-P0.5		YRS-1620						EJ-PID			
SPL-002T-P0.5		YRS-1410									
SPND-001T-C0.5		YRS-1091						EJ-PND			
SPND-002T-C0.5		YRS-1090						EJ-PND			
SPNI-001T-P0.5	YC-610R										
SPNI-002T-P0.5		YRS-1340									
SPS-01T-110	YC-740				WC-740		LPS-01T-110				
SPS-01T-187(-8)	YC-730				WC-730		LPS-01T-187(-8)	EJ-PS187			
SPS-21T-205(-5)	YC-760						LPS-21T-205(-5)				
SPS-21T-250	YC-780				WC-780		LPS-21T-250	EJ-PS250			
SPS-21T-250S	YC-780				WC-780		LPS-21T-250S	EJ-PS250			
SPS-21T-250R	YC-780						LPS-21T-250R	EJ-PS250			
SPS-41T-110	YC-750				WC-750		LPS-41T-110				
SPS-51T-187(-8)	YC-710				WC-710		LPS-51T-187(-8)	EJ-PS187			
SPS-51T-205	YC-770						LPS-51T-205				
SPS-61T-250	YC-720				WC-720		LPS-61T-250	EJ-PS250			
SPS-61T-250S	YC-720						LPS-61T-250S	EJ-PS250			
SPS-61T-250R	YC-721						LPS-61T-250R	EJ-PS250			
SPS-91T-250							BPS-91T-250	EJ-PS250			
SPS-91T-250S							BPS-91T-250S	EJ-PS250			
SPS-91T-250R							BPS-91T-250R	EJ-PS250			
SPSI-001T-M1.1	YC-335R							EJ-PSIP			
SPSI-41T-M1.1	YC-335R							EJ-PSIP			
SPSM-001T-M1.1	YC-335R							EJ-PSIR			
SPSI-41T-M1.1	YC-225R							EJ-PSIP			
SPSM-41T-M1.1	YC-226R							EJ-PSIR			
SPUD-001T-P0.5		YRS-1320						EJ-PUD			
SPUD-002T-P0.5		YRS-1520						EJ-PUD			

Note: Contact JST for wire range.

Terminals and parts model number in alphabetical order	Hand tools							Extraction and Insertion tools			
	for loose piece terminals				for chain terminals			YRS series	YC series	YRM series	YRF series
	YRK · YRK-EX series	WC & JUC series	JUK's Hand Tools	Terminal in loose form model No.	Extraction tool	Insertion tool	Hand tools				
SPXA-001T-P0.6	-	-	-	-	-	-	-	-	-	EJ-PXA	-
SRA-20(T)**	-	-	-	-	-	-	-	-	-	-	-
SRA-21(T)**	-	-	-	-	-	-	-	-	-	-	-
SRA-50(T)**	-	-	-	-	-	-	-	-	-	-	-
SRA-51(T)**	-	-	-	-	-	-	-	-	-	-	-
SRB-1.0(-)	-	-	-	-	-	-	-	-	-	-	-
SRB-2.5(-)	-	-	-	-	-	-	-	-	-	-	-
SRB-51(T)**	-	-	-	-	-	-	-	-	-	-	-
SRC-01(T)**	-	-	-	-	-	-	-	-	-	-	-
SRC-50(T)**	-	-	-	-	-	-	-	-	-	-	-
SRC-51(T)**	-	-	-	-	-	-	-	-	-	-	-
SRF-51(T)**	-	-	-	-	-	-	-	-	-	-	-
SRFCP-002GG-M0.9	YRS-1530	-	-	-	-	-	-	-	-	EJ-RFC-P	-
SRLF-01GG-S0.9	-	-	-	-	-	-	-	-	-	EJ-RFC-R	-
SRLF-61GG-S0.9	-	-	-	-	-	-	-	-	-	EJ-RFC-R	-
SRFM-01GG-S0.9	-	-	-	-	-	-	-	-	-	EJ-RPZ	-
SRFM-61GG-S0.9	-	-	-	-	-	-	YRF-1450	-	-	EJ-RPZ	-
SRICM-61T-S0.6	-	-	-	-	-	-	-	-	-	-	-
SRICM-61GG-S0.6	-	-	-	-	-	-	-	-	-	-	-
SRT-1.0(-)	-	-	-	-	-	-	-	-	-	-	-
SRT-2.5(-)	-	-	-	-	-	-	-	-	-	-	-
SRT-51T**	YC-143R	-	-	-	-	-	-	-	-	-	-
SRWF-01GG-M0.6	-	-	-	-	-	-	-	-	-	EJ-RPZ	-
SRWF-01T-M0.6	-	-	-	-	-	-	-	-	-	-	-
SRWF-21GG-M0.6	-	-	-	-	-	-	-	-	-	EJ-RPZ	-
SRWF-61GG-M0.6	-	-	-	-	-	-	-	-	-	EJ-RPZ	-
SRWF-61T-M0.6	YC-840R	-	-	-	-	-	-	-	-	-	-
SRWM-61GG-S0.6	-	-	-	-	-	-	-	-	-	-	-
SSFH-001T-P0.5	YRS-1581	-	-	-	-	-	-	-	-	EJ-SFH	-
SSFH-002T-P0.5	YRS-1490	-	-	-	-	-	-	-	-	EJ-SFH	-
SSH-003T-P0.2-H	YRS-859	-	-	-	-	-	-	-	-	-	-
SSH-003GA-P0.2	YRS-859	-	-	-	-	-	-	-	-	-	-
SSHJ-003T-P0.2	YRS-859	-	-	-	-	-	-	-	-	-	-
SSHL-002T-P0.2	YRS-1590	-	-	-	-	-	-	-	-	-	-
SSHL-003T-P0.2	YRS-859	-	-	-	-	-	-	-	-	-	-
SSHL-003GA1-P0.2	YRS-859	-	-	-	-	-	-	-	-	-	-
SSF-01T-P1.4	YC-500	-	-	-	-	-	-	-	-	-	-
SSF-21T-P1.4	YC-550	-	-	-	-	-	-	-	-	-	-
SSM-01T-P1.4	-	-	-	-	-	-	-	-	-	SLJ-1.4	ITBL-08V
SSM-21T-P1.4	YC-550	-	-	-	-	-	-	-	-	SLJ-1.4	-
STI-01(T)-110N	YC-041	-	-	-	-	-	-	-	-	-	-
STI-1.0-250D/N	-	-	-	-	-	-	-	-	-	-	-
STI-2.5-250D/N	-	-	-	-	-	-	-	-	-	-	-
STI-41(T)-110N	YC-063	-	-	-	-	-	-	-	-	-	-
STI-51(T)-250N	YC-322	-	-	-	-	-	-	-	-	-	-
STO-01(T)-110N(-8)	YC-041	-	-	-	-	-	-	-	-	-	-
STO-01(T)-187N(-8)	YC-042	-	-	-	-	-	-	-	-	-	-

Note: Contact JST for wire range.

Terminals and parts model number in alphabetical order	Hand tools			Hand tools			Hand tools			Insertion tool
	for chain terminals	for loose piece terminals	for loose piece terminals	WC & JUC series	JUK's Hand Tools	Terminal in loose form model No.	Extraction tool	Extraction tool	Insertion tool	
STO-0.25-110N	-	YC-810	-	-	-	-	-	-	-	-
STO-0.5-110N	-	YC-820	-	-	-	-	-	-	-	-
STO-1.0-110N	-	-	-	-	-	-	-	-	-	-
STO-1.0-187N	-	-	-	-	-	-	-	-	-	-
STO-1.0-250N	-	-	-	-	-	-	-	-	-	-
STO-2.5-250N	-	-	-	-	-	-	-	-	-	-
STO-21(T)-205N(-5)	-	YC-053	-	-	-	-	-	-	-	-
STO-21(T)-250N	-	YC-102	-	-	-	-	-	-	-	-
STO-41(T)-110N(-8)	-	YC-062	-	-	-	-	-	-	-	-
STO-41(T)-187N(-8)	-	YC-051	-	-	-	-	-	-	-	-
STO-41T-187S	-	YC-064	-	-	-	-	-	-	EJ-187S	-
STO-61(T)-250N	-	YC-047	-	-	-	-	-	-	-	-
STO-81(T)-250N	-	YC-280	-	-	-	-	-	-	-	-
STS-002GG-P0.6	YRS-1360	-	-	-	-	-	-	-	-	-
STSD-002GG-P0.6	-	-	-	-	-	-	-	-	EJ-TSD	-
SVA-41T-P1.1	-	YC-450	-	-	-	-	-	-	-	-
SVF-01T-1.5A	-	YC-044	-	-	-	-	-	-	-	-
SVF-01T-1.5N	-	YC-151	-	-	-	-	-	-	-	-
SVF-01T-2.36N	-	YC-152	-	-	-	-	-	-	-	-
SVF-42T-P2.0	-	YC-592	-	-	-	-	-	-	-	-
SVM-42T-P2.0	-	YC-593	-	-	-	-	-	-	-	-
SVF-61T-P0.2	-	YC-590	-	-	-	-	-	-	-	-
SVM-61T-P0.2	-	YC-590	-	-	-	-	-	-	-	-
SVF-81T-P0.2	-	-	-	-	-	-	-	-	-	-
SVM-81T-P0.2	-	YRF-591	-	-	-	-	-	-	-	-
SVH-21T-P1.1	-	YC-160R YC-161R YC-164R	YRM-160 -	-	-	-	-	-	-	-
SVH-41T-P1.1	-	YC-930R YC-931R	-	-	-	-	-	-	-	-
SVSF-61T-S2.0	-	-	-	-	-	-	-	-	-	-
SVSM-61T-S2.0	-	YRF-590	-	-	-	-	-	-	-	-
SVSF-81T-S2.0	-	-	-	-	-	-	-	-	-	-
SVSM-81T-S2.0	-	YRF-591	-	-	-	-	-	-	-	-
SVT-41T-P1.1	-	YC-630	-	-	-	-	-	-	-	-
SVU-21T-P0.6	-	YC-990R	-	-	-	-	-	-	-	-
SVYF-61T-P0.5A	-	-	-	-	-	-	-	-	-	-
SWPJT-21T-P0.5	-	-	-	-	-	-	-	-	-	-
SWPJT-21T-P0.5A	-	-	-	-	-	-	-	-	-	-
SWPJR-21T-M0.5	-	-	-	-	-	-	-	-	-	-
SWPKP-21T-0.6	-	-	-	-	-	-	-	-	-	-
SWPKR-21T-0.6	-	-	-	-	-	-	-	-	-	-
SWPR-001T-P0.25	YRS-980	-	-	-	-	-	-	-	-	-
SWPT-001T-P0.25	-	-	-	-	-	-	-	-	-	-
SXA-01T-P0.6	YRS-701	YC-701R	-	-	-	-	-	-	-	-
SXA-001T-P0.6	YRS-692	YC-692R	-	-	-	-	-	-	-	-
SXA-001T-P0.6L	YRS-691	-	-	-	-	-	-	-	-	-

Note: Contact JST for wire range.

Terminals and parts model number in alphabetical order	Hand tools				for loose piece terminals				YRS series	YC series	YRM series	YRF series	YRK · YRK-EX series	WC & JUC series JUK's Hand Tools for loose piece terminals	Terminal in loose form model No.	Extraction tool	Insertion tool
	Hand tools		for loose piece terminals		for loose piece terminals		for chain terminals										
SXAM-01T-P0.6	YRS-701	YC-701R	-	-	-	-	-	-	-	-	-	-	WC-700M	BXAM-01T-P0.6	EJ-XAW	-	
SXAM-001T-P0.6	YRS-692	YC-692R	-	-	-	-	-	-	-	-	-	-	-	BXAM-001T-P0.6	EJ-XAW	-	
SXF-01T-P0.7	-	YC-251	-	-	-	-	-	-	-	-	-	-	-	BXF-01T-(P)0.7	LEJ-7	-	
SXF-41T-P0.7	-	YC-252	-	-	-	-	-	-	-	-	-	-	-	BXF-41T-(P)0.7	LEJ-7	-	
SXH-001T-P0.6	YRS-110	YC-110R	-	-	-	-	-	-	-	-	-	-	WC-110	BXH-001T-P0.6	XJ-06	-	
SXH-001T-P0.6N	-	-	-	-	-	-	-	-	-	-	-	-	-	-	XJ-06	-	
SXH-002T-P0.6	YRS-480	-	-	-	-	-	-	-	-	-	-	-	-	-	XJ-06	-	
SXM-01T-P0.6	YRS-701	YC-701R	-	-	-	-	-	-	-	-	-	-	-	BXM-01T-P0.6	EJ-XAG, EJ-XMP	-	
SXM-001T-P0.6	YRS-692	YC-692R	-	-	-	-	-	-	-	-	-	-	-	BXM-001T-P0.6	EJ-XMP, EJ-XMR	IT-XA	
SXNI-001T-P0.6	YRS-1380	-	-	-	-	-	-	-	-	-	-	-	-	-	-	-	
SXNI-003T-P0.6	YRS-1390	-	-	-	-	-	-	-	-	-	-	-	-	-	-	-	
SYF-001T-P0.6	YRS-125	-	-	-	-	-	-	-	-	-	-	-	-	-	-	-	
SYF-01T-P0.5A	-	YC-520	-	-	-	-	-	-	-	-	-	-	WC-520	BYF-01T-P0.5A	YLJ-0.5	-	
SYF-41T-P0.5A	-	YC-530	-	-	-	-	-	-	-	-	-	WC-530	BYF-41T-P0.5A	YLJ-0.5	-		
SYM-41T-P0.5A	-	YC-536	-	-	-	-	-	-	-	-	-	YRF-536	BYM-41T-P0.5A	YLJ-0.5	-		
SYM-001T-P0.6	YRS-121	YC-121R	-	-	-	-	-	-	-	-	-	WC-121	BYM-001T-P0.6	SMJ-06	-		
SYM-01T-P0.7	-	YC-251	-	-	-	-	-	-	-	-	-	-	BYM-01T-(P)0.7	LEJ-7	-		
SYM-41T-P0.7	-	YC-252	-	-	-	-	-	-	-	-	-	-	BYM-41T-(P)0.7	LEJ-7	-		
SZE-002T-P0.3	YRS-1460	-	-	-	-	-	-	-	-	-	-	-	-	-	-	-	
SZE-003T-P0.3	YRS-1330	-	-	-	-	-	-	-	-	-	-	-	-	-	-	-	
SZF-01T-P0.7	-	YC-390R	-	-	-	-	-	-	-	-	-	-	-	BZF-01T-(P)0.7	ZLJ-0.7S	-	
SZF-41T-P0.7	-	YC-380R	-	-	-	-	-	-	-	-	-	-	-	BZF-41T-(P)0.7	ZLJ-0.7S	-	
SZH-002T-P0.5	YRS-491	-	-	-	-	-	-	-	-	-	-	-	WC-491	-	-	-	
SZH-003T-P0.5	YRS-490	-	-	-	-	-	-	-	-	-	-	-	WC-490	-	-	-	
SZN-002T-P0.7K	YRS-541	-	-	-	-	-	-	-	-	-	-	-	-	-	-	-	
SZN-003T-P0.7K	YRS-540	-	-	-	-	-	-	-	-	-	-	-	-	-	-	-	
SZND-002T-P0.5	YRS-1710	-	-	-	-	-	-	-	-	-	-	-	-	-	-	-	
SZPD-002T-P0.3	YRS-1460	-	-	-	-	-	-	-	-	-	-	-	-	-	-	-	

Note : Contact JST for wire range.



**YRK series hand crimping tools suitable for mass-production**

- Crimping work, such as setting contacts to hand tools etc., is facilitated by using a strip contact to improve the productivity.
- A light operation enables to terminate the contact correctly, by adopting straight-ahead crimping.
- A structure, that the carrier of contact doesn't fly off, has been adopted to this tool.



Dimensions: 75(W)×314(L)×25(D) mm  
Weight: Approx. 800 g (When assembling dies)

**Hand Crimping Tools**  
**YRK Standard type**

- When exchanging the crimper, the crimping suitable for the wire specification can be conducted.
- Anvil is fixed to tool.

**Contact and Applicable dies**

Series	Nominal	Contact Model No.		Hand crimp tools	Model No. of crimper	Marking	AWG	Insulation O.D. (mm)
		Tab	Receptacle					
J1000 Type II	L	SF1F-21(*)-P0.6	SF1M-21(*)-M0.6A	YRK-1210	LA / LB	LA	#22	1.58
					LC / LD	LD	#18	2.03
					SA / SB	SA	#28	1.20
					SA / SB	SB	#24	1.43
					MA / MB	MA	#24	1.43
					MB	MB	#20	1.53 <sup>2</sup>
	M	SJ2F-01GF-P1.0	SJ2M-01GF-M1.0N	MA / MB	MA	#24	1.43	
				LA / LB	LA	#22	1.58	
				LB	LB	#20	1.76	
				SA / SB	SA	#28	1.20	
				SA / SB	SB	#24	1.43	
				SB	SB	#24	1.43	
J2000	L	SJ2F-21GF-P1.0	SJ2M-21GF-M1.0N	YRK-1120	LA / LB	LA	#22	1.58
					LC / LD	LD	#18	2.03
					SA / SB	SA	#28	1.20
					SA / SB	SB	#24	1.43
					MA / MB	MA	#24	1.43
					MB	MB	#20	1.53 <sup>2</sup>
	M	SJ2F-01GF-P1.0	SJ2M-01GF-M1.0N	MA / MB	MA	#24	1.43	
				LA / LB	LA	#22	1.58	
				LB	LB	#20	1.76	
				SA / SB	SA	#28	1.20	
				SA / SB	SB	#24	1.43	
				SB	SB	#24	1.43	
J300	S	SF3F-002(*)-P2.0	SF3M-002(*)-M2.0N	YRK-8821	SC / SD	SC	#26	1.30
					SA / SB	SA	#28	1.20
					SA / SB	SB	#24	1.43
					MA / MB	MA	#24	1.43
					MA / MB	MB	#20	1.76
					MC / MD	MC	#22	1.58
	M	SF3F-01(*)-P2.0	SF3M-01(*)-M2.0N	YRK-8811	MC / MD	MD	#20	2.56
					LA / LB	LA	#20	1.76
					LA / LB	LB	#16	2.35
					LC / LD	LC	#18	2.03
					LC / LD	LD	#18	2.83
					2LA / 2LB	2LA	#16	3.10
J3000	L	SF3F-41(*)-P2.0	SF3M-41(*)-M2.0N	YRK-8801	LA / LB	LA	#20	1.76
					LA / LB	LB	#16	2.35
					LC / LD	LC	#18	2.03
					LC / LD	LD	#18	2.83
					2LA / 2LB	2LA	#16	3.10
					2LB	2LB	#14	3.30
	2L	SF3F-71(*)-P2.0	SF3M-71(*)-M2.0N	YRK-1071	2LA / 2LB	2LA	#16	3.10
					2LA / 2LB	2LB	#14	3.30

Note: 1. J1000 Finish(\*): T..... Tin-plated  
GC..... Gold-plated  
GF..... Nickel-undercoated, 0.38µm selective gold-plated  
2. J300 Finish(\*): GF..... Nickel-undercoated, 0.76µm selective gold-plated  
T..... Tin-plated  
3. The wear of parts is caused by using hand tool repeatedly. Measure the crimping height daily and conduct periodical inspection of the wearing parts, such as ratchet, pin and so on.

**Contact and Applicable dies**

Series	Nominal	Contact Model No.		Anvil	Color mark	Common parts									
		Tab	Receptacle												
J1000 Type II	L	SF1F-21(*)-P0.6	SF1M-21(*)-M0.6A	J1LL	Yellow green	Handle unit Upper pin Lower pin Case									
							J1LA / B	A	#20	1.76					
							J1LC / D	C	#22	1.58					
							J1LC / D	D	KV0.75	1.90					
							J1SA / B	A	#28	1.20					
							J1SA / B	B	#24	1.43					
	S	SJ2F-002GF-P1.0	SJ2M-002GF-M1.0N	J2SL	White	J2SA / B	A	#28	1.20						
							B	#24	1.43						
							A	#24	1.43						
							B	#20	1.53 <sup>2</sup>						
							J2LA / B	A	#22	1.58					
							J2LA / B	B	#20	1.76					
J2000	L	SJ2F-21GF-P1.0	SJ2M-21GF-M1.0N	J2LL	Orange	J2LA / B	A	#22	1.58						
							B	#20	1.76						
							M	SJ2F-01GF-P1.0	SJ2M-01GF-M1.0N	J2ML	Purple	J2MA / B	B	#20	1.53 <sup>2</sup>
													A	#24	1.43
													A	#24	1.43
													B	#24	1.43
	J2SA / B	A	#28	1.20											
	J2SA / B	B	#24	1.43											
	J3000	S	SF3F-002(*)-P2.0	SF3M-002(*)-M2.0N	J3SL	Yellow	J3SA / B	A	#28	1.20					
								B	#24	1.43					
								C	#26	1.30					
								D	#24	1.11					
J3MA / B								A	#24	1.43					
J3MA / B								B	#20	1.76					
M		SF3F-01(*)-P2.0	SF3M-01(*)-M2.0N	J3ML	Green	J3MC / D	D	#20	2.56						
							C	#22	1.58						
							B	#20	1.76						
							A	#20	1.76						
							J3LA / B	A	#20	1.76					
							J3LA / B	B	#16	2.35					
L	SF3F-41(*)-P2.0	SF3M-41(*)-M2.0N	J3LL	Red	J3LC / D	C	#18	2.03							
						D	#18	2.83							
						A	#16	2.35							
						B	#16	2.35							
						2LA / 2LB	2LA	#16	3.10						
						2LB	2LB	#14	3.30						
2L	SF3F-71(*)-P2.0	SF3M-71(*)-M2.0N	J32LL	Blue	J32LA / B	A	#16	3.10							
						B	#14	3.30							

Note: 1. J1000 Finish(\*): T..... Tin-plated  
GC..... Gold-plated  
GF..... Nickel-undercoated, 0.38µm selective gold-plated  
2. J300 Finish(\*): GF..... Nickel-undercoated, 0.76µm selective gold-plated  
T..... Tin-plated  
3. The wear of parts is caused by using hand tool repeatedly. Measure the crimping height daily and conduct periodical inspection of the wearing parts, such as ratchet, pin and so on.



Dimensions: 75(W)×314(L)×25(D) mm  
Weight: Approx. 800 g (When assembling dies)

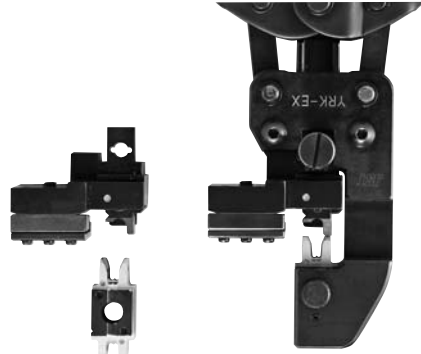

Patent pending

**YRK-EX**  
**Dies replacement type hand crimping tools**

- High reliability of crimping is provided by choosing the crimper and anvil suitable for the wire specification.
- The crimping die can be easily exchanged by only insertion and extraction of pin.
- Common handle and crimping dies can be stored in One case and it is easy to carry.

## X-ON Electronics

Largest Supplier of Electrical and Electronic Components

*Click to view similar products for [jst manufacturer](#):*

Other Similar products are found below :

[B3B-ZR](#) [B4B-ZR](#) [B5B-XH-A](#) [B5B-ZR](#) [B6B-ZR-SM4-TF](#) [B7B-XH-A](#) [B8B-XH-A](#) [B8B-ZR](#) [BM02B-SRSS-TB](#) [BM06B-SRSS-TB](#) [BM10B-SRSS-TB](#) [FVGS5-6](#) [B2B-ZR-SM4-TF](#) [B34B-PHDSS-B\(LF\)\(SN\)](#) [B3B-ZR-SM4-TF](#) [B5B-ZR-SM4-TF](#) [B6B-XH-A](#) [B7B-ZR-SM4-TF](#) [B8B-ZR-SM4-TF](#) [B8PS-VH](#) [BM04B-SRSS-TB](#) [BM05B-SRSS-TB](#) [IDH-KR-12](#) [WC-ZE2426](#) [WC-691](#) [FVDDF5.5-375A \(LF\)](#) [FVGS12-6 \(LF\)](#) [FVWS2-S3.3 \(LF\)](#) [FVWS5.5-5 \(LF\)](#) [B6PS-VH\(LF\)\(SN\)](#) [FNGS12-6](#) [TWE0.5-8](#) [FVGS4-1 \(LF\)](#) [WC-GVH2630](#) [WC-PUD2](#) [S10B-PH-SM4-TB\(LF\)\(SN\)](#) [B2B-EH-A-TW \(LF\)\(SN\)](#) [B4B-EH-A-TW \(LF\)\(SN\)](#) [B4B-XH-TW \(LF\)\(SN\)](#) [B9B-XH-A](#) [BM02B-GHS-TBT](#) [BM03B-GHS-TBT](#) [BM04B-GHS-TBT](#) [BM06B-GHS-TBT](#) [BM08B-GHS-TBT](#) [BM10B-GHS-TBT](#) [SM10B-GHS-TB](#) [10FPZ-SM-TF\(LF\)\(SN\)](#) [YRS-852](#)  
[B04B-VYHSK-M-1](#)