

# RF CONNECTOR

Disconnectable Crimp style connectors

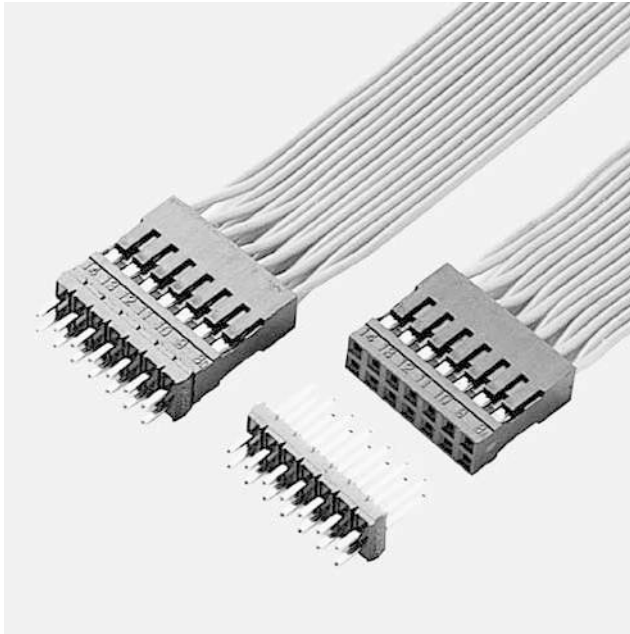

The RF connector was developed as a highly reliable, low-cost, crimp style connector for connecting wires to printed circuit boards. Well suited for internal connections in office automation equipment, such as personal computers, office computers and their peripheral devices.

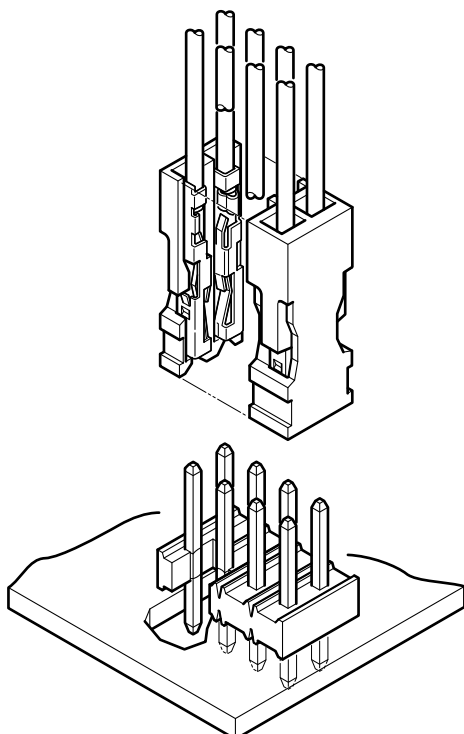

## Features

### • Highly reliable, yet low in cost

Our original double-leaf spring construction withstands the stresses caused by repeated insertions and withdrawals and ensures reliable contact performance. Depending on the application, the socket contacts and header posts can be selectively gold-plated or fully tin-plated to minimize costs.

### • Space-saving, high-density design

The 2.54mm pitch contacts are arranged in two rows. The mated connectors can be placed side by side or end to end without a loss in pitch. This facilitates space-saving, high-density circuit designs.

### • Easy connection

A slight force is all that is required for contact insertion because the housing has resilient lances. Furthermore, the positions of the contacts in the housing can be visually checked. This facilitates insertion of the contacts in the housing.

### • It can be cut to any length to provide a header with any number of circuits

Notches are provided on the insulator that allow it to be cut to any length without using special tools.

## Specifications

- Current rating: 2A AC, DC (AWG #24)
- Voltage rating: 250V AC, DC
- Temperature range: (including temperature rise in applying electrical current)
  - 55°C to +105°C (gold-plated)
  - 55°C to +85°C (tin-plated)
- Contact resistance: Initial value/15mΩ max.  
After environmental testing/30mΩ max.
- Insulation resistance: 1,000MΩ min.
- Withstanding voltage: 1,500V AC/minute
- Applicable wire: AWG #30 to #24
- Applicable PC board thickness: 1.2 to 1.6mm
- \* Compliant with RoHS.
- \* Refer to "General Instruction and Notice when using Terminals and Connectors" at the end of this catalog.
- \* Contact JST for details.

## Standards

- Ⓜ Recognized E60389
- Ⓢ Certified LR20812

# RF CONNECTOR

## Contact

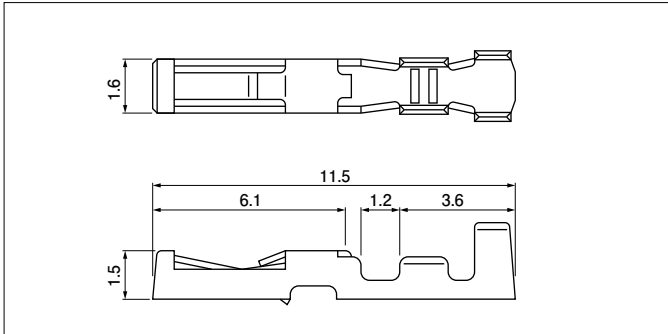

Model No.	Applicable wire			Finish	Q'ty / reel
	mm <sup>2</sup>	AWG #	Insulation O.D. (mm)		
RF-SC2210	0.05 to 0.22	30 to 24	0.9 to 1.5	Nickel-undercoated, Mating part: gold-plated Crimping part: tin-plated (reflow treatment)	10,000
RF-SC2290				Tin-plated (reflow treatment)	

### Material

Phosphor bronze

RoHS compliance RF-SC2210 displays (LF)(SN) on a label.

## Housing

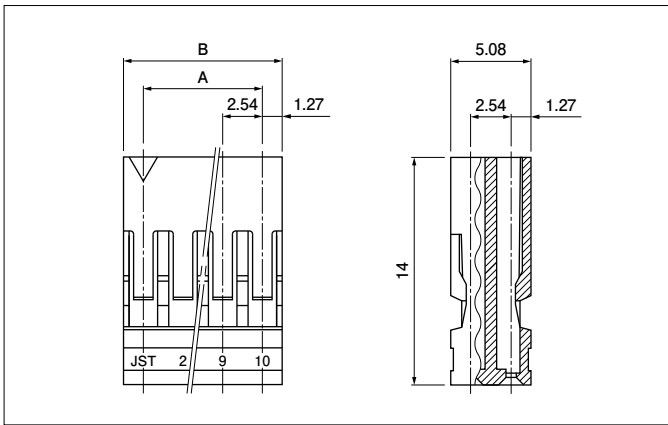

No. of circuits	Model No.	Dimensions (mm)		Q'ty / box
		A	B	
6	RF-06	5.08	7.62	500
8	RF-08	7.62	10.16	500
10	RF-10	10.16	12.70	500
12	RF-12	12.70	15.24	500
14	RF-14	15.24	17.78	300
16	RF-16	17.78	20.32	300
20	RF-20	22.86	25.40	200
28	RF-28	33.02	35.56	200

### Material

PBT, UL94V-0, black

RoHS compliance

## Header

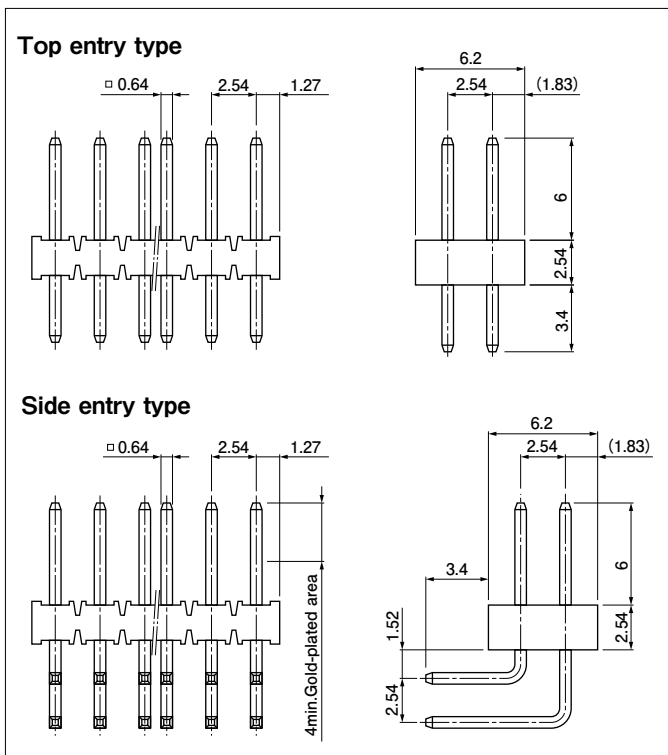

### Top entry type

Model No.	Material		Finish
	Wafer	Post	
RF-H ( *) 2TD-1130	PBT, UL94V-0, black	Brass	Nickel-undercoated, gold-plated
RF-H ( *) 2TD-1190			Copper-undercoated, tin-plated (reflow treatment)

### Side entry type

Model No.	Material		Finish
	Wafer	Post	
RF-H ( *) 2SD-1110	PBT, UL94V-0, black	Brass	Nickel-undercoated, Mating part: gold-plated Solder tail: tin-plated (reflow treatment)
RF-H ( *) 2SD-1190			Copper-undercoated, tin-plated (reflow treatment)

RoHS compliance Tin-plated product displays (LF)(SN) on a label.

Note:

1. A two-digit number (02 to 60 even numbers only) representing the number of circuits should be inserted in (\*). Determine the number depending on the number of circuits of the housing or header.
2. Contact JST for special products.

## Polarizing key

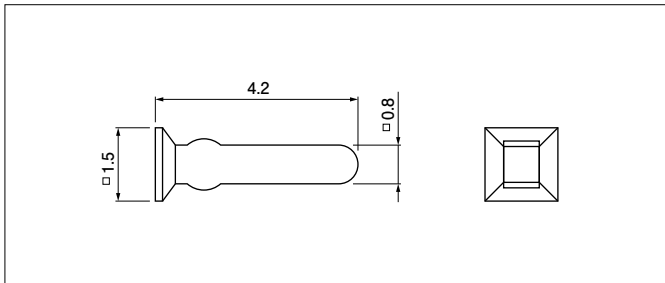

Model No.	Q'ty / bag
PK-RF-1	10,000
Material	
PBT, UL94V-0, natural (white)	

### RoHS compliance

Polarizing key: The polarizing key in the housing prevents misinsertion of the connector to the header.

## PC board layout (viewed from soldering side) and Assembly layout

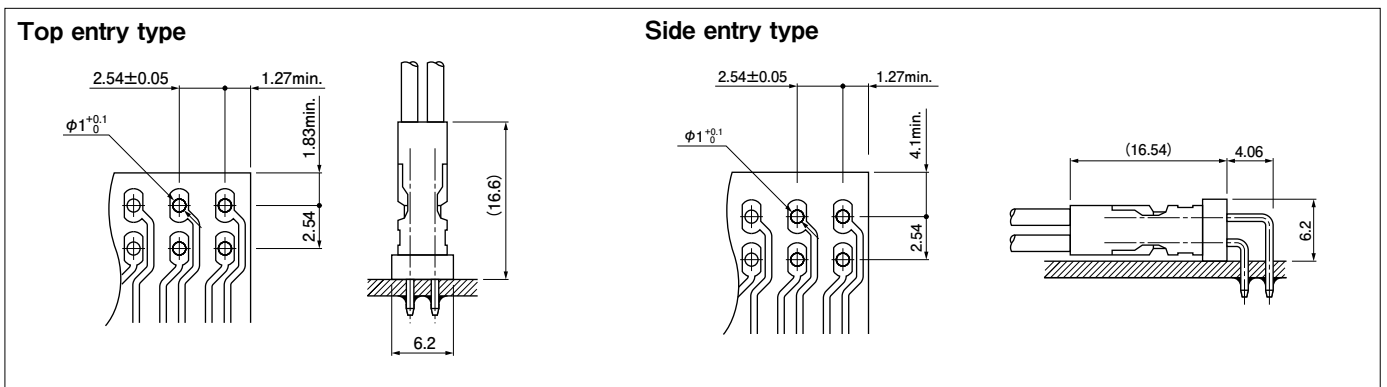

### Note:

1. Tolerances are non-cumulative:  $\pm 0.05\text{mm}$  for all centers.

2. Hole dimensions differ according to the type of PC board and piercing method. The dimensions above should serve as a guideline. Contact JST for details.

# RF CONNECTOR

## Model number allocation

### Contact

**RF - S C 2 2 10**

Series name \_\_\_\_\_

Form: S··Strip form \_\_\_\_\_

Part name: C··Crimp style contact \_\_\_\_\_

Applicable wire range: 2··AWG #30 to #24 \_\_\_\_\_

Material: 2··Phosphor bronze \_\_\_\_\_

Surface finish of contact part: 10··Gold-plated (Flash) \_\_\_\_\_  
 90··Tin-plated (reflow treatment) \_\_\_\_\_

### Housing

**RF - 06**

Series name \_\_\_\_\_

No. of circuits: 6, 8, 10, 12, 14, 16, 20, 28 \_\_\_\_\_

### Header

**RF - H 34 2 TD - 1 1 30**

Series name \_\_\_\_\_

Part name: Header \_\_\_\_\_

No. of circuits: Even number from 2 to 60 \_\_\_\_\_

Mating side post length: 6.0 \_\_\_\_\_

PC board mounting method: TD··Top entry DIP type \_\_\_\_\_  
 SD··Side entry DIP type \_\_\_\_\_

Header color: 1··Black \_\_\_\_\_

Post material: 1··Brass \_\_\_\_\_

Surface finish of post: 10··Selective gold-plated (Flash) \_\_\_\_\_  
 30··Overall gold-plated (Flash) \_\_\_\_\_  
 90··Tin-plated (reflow treatment) \_\_\_\_\_

### Polarizing key

**PK - RF - 1**

Part name: Polarizing key \_\_\_\_\_

Series name \_\_\_\_\_

Material/Color: 1··Normal type (PBT, White) \_\_\_\_\_

## Crimping machine, Applicator

Contact	Crimping machine	Applicator		
		Crimp applicator	Dies	Crimp applicator with dies
RF-SC2210	AP-K2N	MKS-L	MK/RF-SC22	APLMK RF-SC22
RF-SC2290				

Note: Contact JST for fully automatic crimping applicator.

## X-ON Electronics

Largest Supplier of Electrical and Electronic Components

*Click to view similar products for [Headers & Wire Housings](#) category:*

*Click to view products by [JST](#) manufacturer:*

Other Similar products are found below :

[57102-F02-18ULF](#) [58102-G61-06LF](#) [582553-1](#) [009176003701906](#) [01.001.5753.1](#) [0050291907](#) [02.125.8002.8](#) [609-3404](#) [61062-3](#)  
[CSU011177004](#) [622-0430](#) [622-3653LF](#) [63453-116](#) [636-1030](#) [636-1427](#) [636-3427](#) [636-4007](#) [641938-9](#) [65495-038](#) [65692-001LF](#) [65781-018](#)  
[65781-047](#) [65817-010LF](#) [65817-015LF](#) [66207-023LF](#) [67095-007LF](#) [67601157](#) [68631-112](#) [68645-018](#) [699319-000](#) [M90C108951C](#)  
[70.362.1628.0](#) [70-4210](#) [70-4226B](#) [70-4853B](#) [707-5028](#) [71.350.2428.0](#) [71961-016LF](#) [733-134](#) [733-162](#) [754199-000](#) [760-3052](#) [80.063.4001.1](#)  
[800-90-001-10-001000](#) [800-90-010-10-002000](#) [801-43-002-10-013000](#) [801-43-006-10-002000](#) [803-41-018-10-001000](#) [803-43-024-10-](#)  
[001000](#) [803-93-012-10-001000](#)