



# ES5ABF THRU ES5JBF

## Surface Mount Superfast Rectifiers

Reverse Voltage – 50 to 600 V

Forward Current – 5 A

### FEATURES

- For surface mounted applications
- Low profile package
- Glass Passivated Chip Junction
- Superfast reverse recovery time
- Lead free in comply with EU RoHS 2011/65/EU directives

### MECHANICAL DATA

- Case: SMBF
- Terminals: Solderable per MIL-STD-750, Method 2026
- Approx. Weight: 57mg / 0.002oz

### PINNING

PIN	DESCRIPTION
1	Cathode
2	Anode

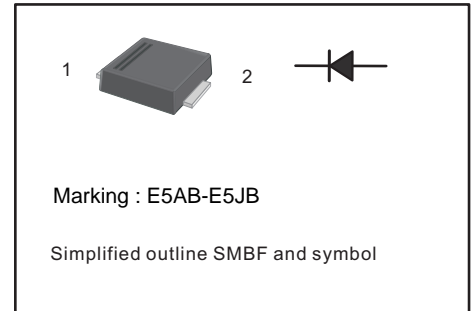

### Absolute Maximum Ratings and Characteristics

Ratings at 25 °C ambient temperature unless otherwise specified. Single phase, half wave, 60 Hz, resistive or inductive load. For capacitive load, derate current by 20%.

Parameter	Symbols	ES5ABF	ES5BF	ES5CBF	ES5DBF	ES5EBF	ES5GBF	ES5JBF	Units	
Maximum Repetitive Peak Reverse Voltage	$V_{RRM}$	50	100	150	200	300	400	600	V	
Maximum RMS voltage	$V_{RMS}$	35	70	105	140	210	280	420	V	
Maximum DC Blocking Voltage	$V_{DC}$	50	100	150	200	300	400	600	V	
Maximum Average Forward Rectified Current at $T_L = 100\text{ }^\circ\text{C}$	$I_{F(AV)}$	5							A	
Peak Forward Surge Current 8.3 ms Single Half Sine Wave Superimposed on Rated Load (JEDEC Method)	$I_{FSM}$	150							A	
Maximum Forward Voltage at 3A	$V_F$	1.0				1.25		1.65	V	
Maximum DC Reverse Current at Rated DC Blocking Voltage $T_a = 25\text{ }^\circ\text{C}$ $T_a = 125\text{ }^\circ\text{C}$	$I_R$	5				100			$\mu\text{A}$	
Typical Junction Capacitance	$C_j$	45								pF
Maximum Reverse Recovery Time at $I_F = 0.5\text{A}$ , $I_R = 1\text{A}$ , $I_{rr} = 0.25\text{A}$	$t_{rr}$	35								ns
Typical Thermal Resistance <sup>2)</sup>	$R_{\theta JA}$	55								$^\circ\text{C/W}$
Operating and Storage Temperature Range	$T_j, T_{stg}$	-55 ~ +150							$^\circ\text{C}$	

1) Measured with  $I_F = 0.5\text{A}$ ,  $I_R = 1\text{A}$ ,  $I_{rr} = 0.25\text{A}$

2) P.C.B. mounted with 0.5 X 0.5" (12.7 X 12.7 mm) copper pad areas.



# ES5ABF THRU ES5JBF Surface Mount Superfast Rectifiers

## Characteristic Curves ( $T_A=25^\circ\text{C}$ unless otherwise noted)

**Fig.1 Reverse Recovery Time Characteristic And Test Circuit Diagram**

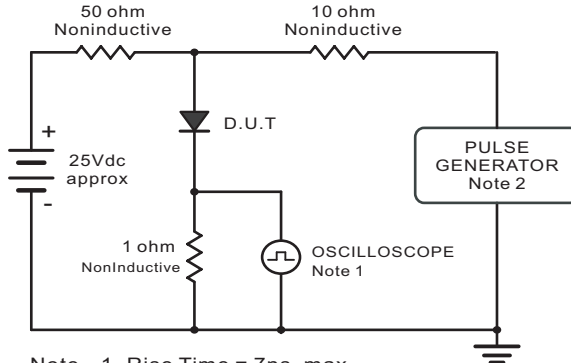

Note: 1. Rise Time = 7ns, max.  
Input Impedance = 1megohm, 22pF.  
2. Rises Time = 10ns, max.  
Source Impedance = 50 ohms.

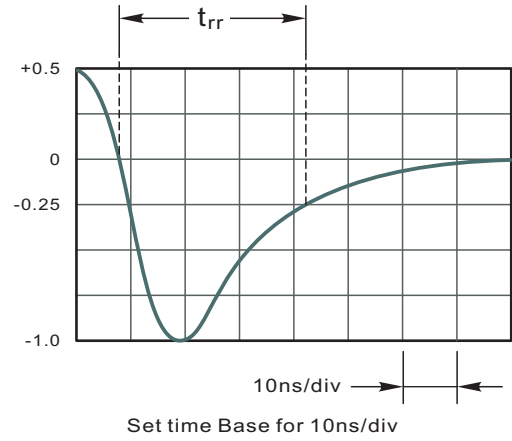

**Fig.2 Maximum Average Forward Current Rating**

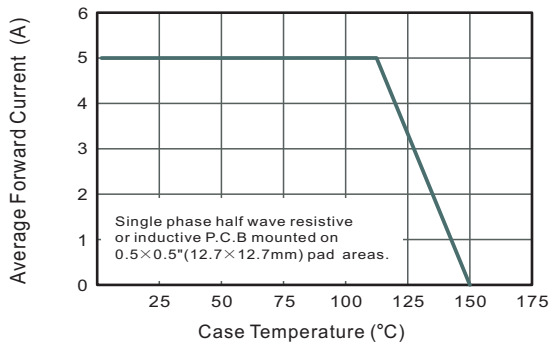

**Fig.3 Typical Reverse Characteristics**

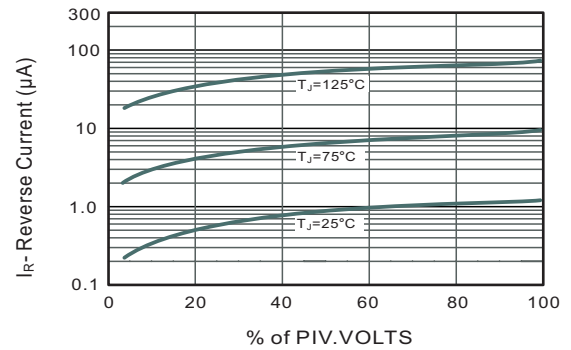

**Fig.4 Typical Forward Characteristics**

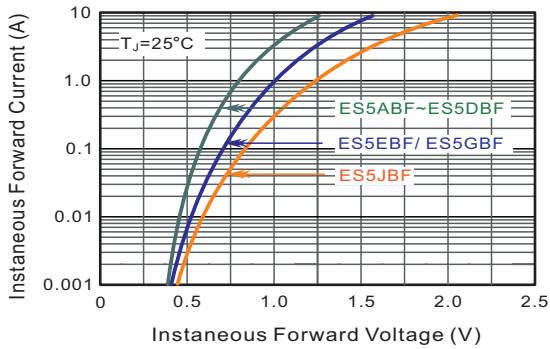

**Fig.5 Typical Junction Capacitance**

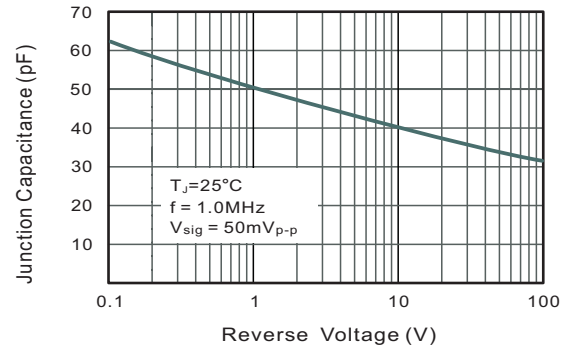

**Fig.6 Maximum Non-Repetitive Peak Forward Surge Current**

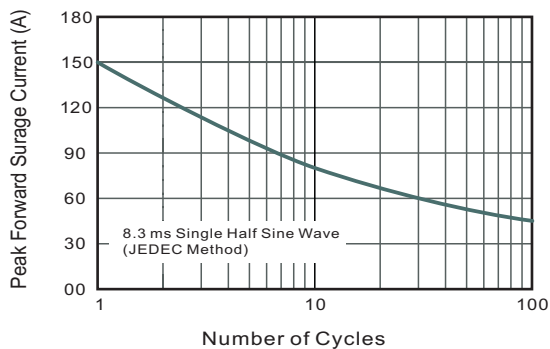



# ES5ABF THRU ES5JBF

## Surface Mount Superfast Rectifiers

### PACKAGE OUTLINE

Plastic surface mounted package; 2 leads

SMBF

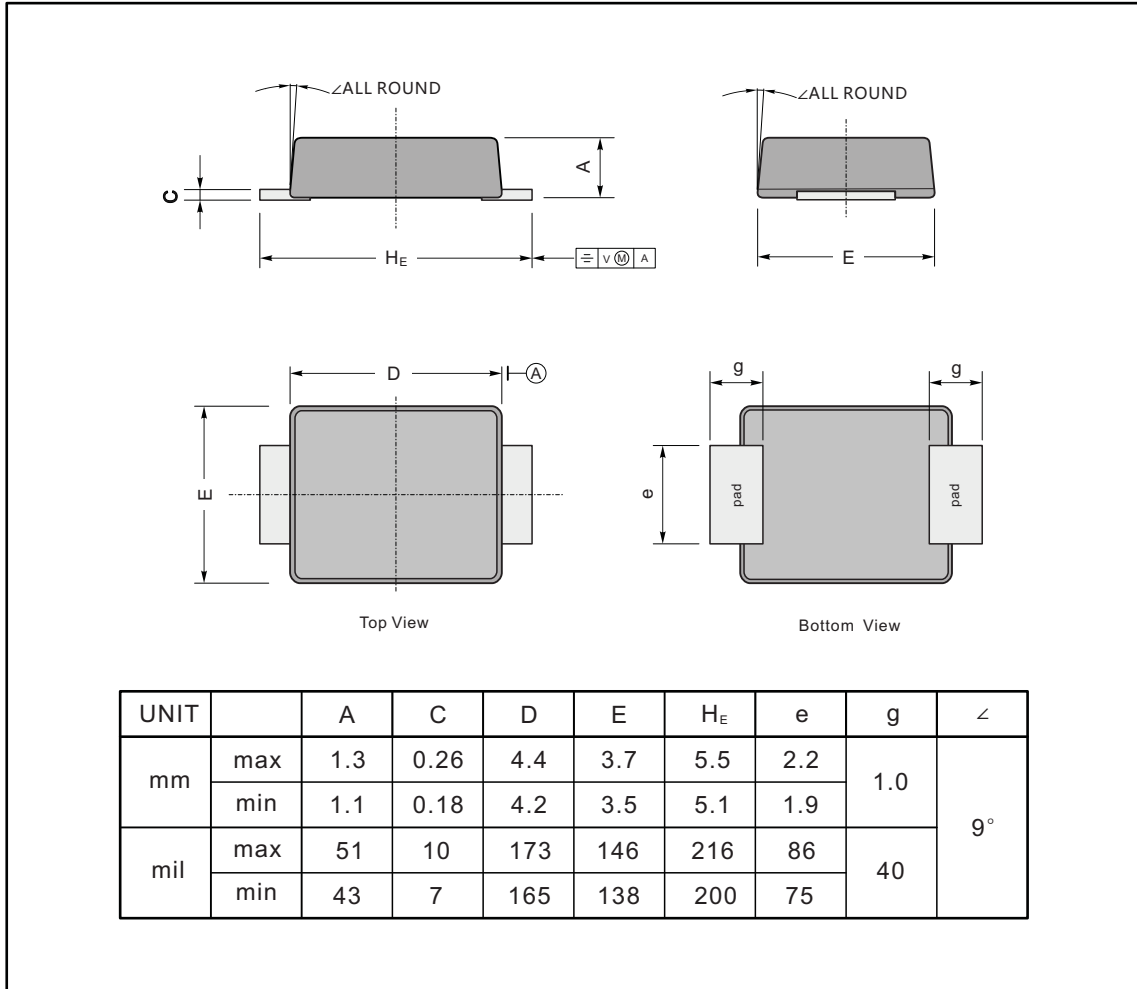

### The recommended mounting pad size

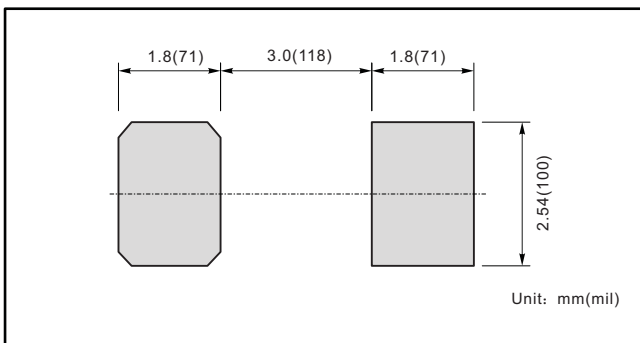

### Marking

Type number	Marking code
ES5ABF	E5AB
ES5BBF	E5BB
ES5CBF	E5CB
ES5DBF	E5DB
ES5EBF	E5EB
ES5GBF	E5GB
ES5JBF	E5JB

## X-ON Electronics

Largest Supplier of Electrical and Electronic Components

*Click to view similar products for [Rectifiers](#) category:*

*Click to view products by [Juxing Electronic Technology](#) manufacturer:*

Other Similar products are found below :

[70HFR40](#) [FR105 R0](#) [RL252-TP](#) [1N5397](#) [1N4005-TR](#) [1N4007-BP](#) [UFS120Je3/TR13](#) [20ETS12S](#) [RRE02VS6SGTR](#) [MS306](#) [A1N5404G-G](#)  
[CRF02\(T5L,TEMQ\)](#) [ACGRB207-HF](#) [CLH07\(TE16L,Q\)](#) [CLH03\(TE16L,Q\)](#) [1N5395-TP](#) [UES1302](#) [ACGRC307-HF](#) [ACEFC304-HF](#) [DZ-](#)  
[1380](#) [85HFR60](#) [40HFR60](#) [70HF120](#) [85HFR80](#) [SCF7500](#) [SM100](#) [ACGRA4001-HF](#) [SKN70/08](#) [NTE5819](#) [NTE5827](#) [NTE5828](#) [NTE5911](#)  
[NTE5915](#) [NTE6104](#) [NTE6163](#) [NTE6164](#) [NTE6165](#) [NTE6364](#) [TSD3G](#) [SET130312](#) [NRVUS110VT3G](#) [UES1106](#) [UES1306](#)  
[NRVUS240VT3G](#) [D5FE60-5063](#) [R4000GPS-TP](#) [D4015L56TP](#) [UES1306HR2](#) [FX20K120](#) [D20XB60-7101](#)