

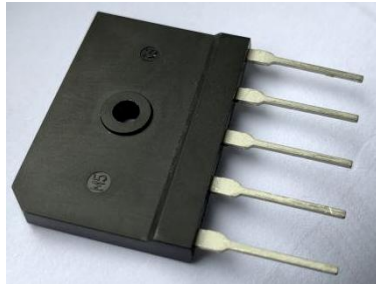

SGBJ3508 THRU SGBJ3516

Glass Passivated Single Phase Bridge Rectifiers



V_{RRM} 800 to 1600V

I_D 35 A

Features

- Glass passivated die construction
- Ideal for printed circuit boards
- High surge current capability
- High temperature soldering guaranteed:
265°C /10 seconds, 0.375" (9.5mm) lead
length, 5lbs. (2.3kg) tension

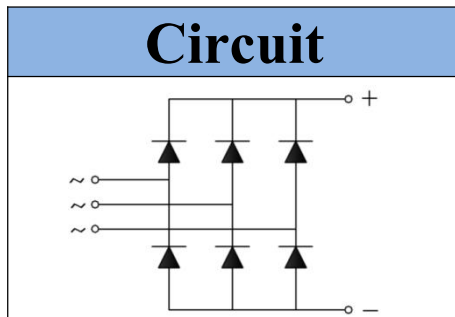

Mechanical Data

Case: Molded plastic case

Terminals: Plated leads solderable per
MIL-STD-750, Method 2026

Polarity: Marked on Body

Mounting Position: Any

Bridge Type

TYPE	V _{RRM}	V _{RSM}
SGBJ 3508	800V	900V
SGBJ 3510	1000V	1100V
SGBJ 3512	1200V	1300V
SGBJ 3514	1400V	1500V
SGBJ 3516	1600V	1700V

Maximum Ratings and Thermal Characteristics (TA = 25°C unless otherwise noted)

Symbol	Conditions	Values	Units
I _D	average forward output current sine wave ,R-load T _c =100°C	35	A
I _{FSM}	Peak forward surge current single half sine-wave superimposed on rated load (JEDEC Method) 50Hz T _j =25°C	400	A
I ² t	Rating for fusing (t=1~10ms)	800	A ² s
V _{ISO}	A.C.50/60Hz;R.M.S.;1min	2500	V
T _j , T _{stg}	Operating Junction and storage temperature range	-40 to +150	°C
Ms	Mounting Torque (Recommended torque:0.65 N • m)	0.8	N • m
W _t	Approximate Weight	10	g

Electrical Characteristics (TA = 25°C unless otherwise noted)

Symbol	Conditions	Values	Units
V _{FM}	Maximum Forward Voltage per leg I _F =17.5A T _j =25°C	1.18	V
I _{RRM}	Maximum reverse current at rated blocking voltage per leg T _j = 150°C	3	mA
R _{th(j-c)}	Maximum thermal resistance per ⁽¹⁾ per diode total	7.8 1.3	°C/W

Notes: (1) Junction to case



Performance Curves

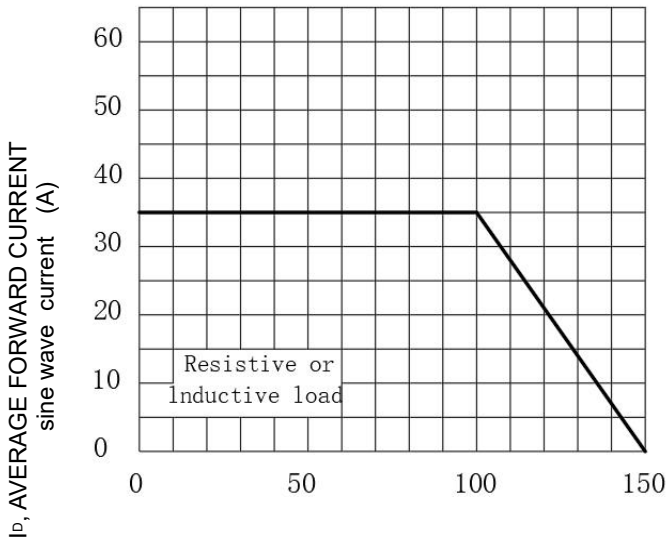

T_c , TEMPERATURE (°C)
Fig.1 Forward Current Derating Curve

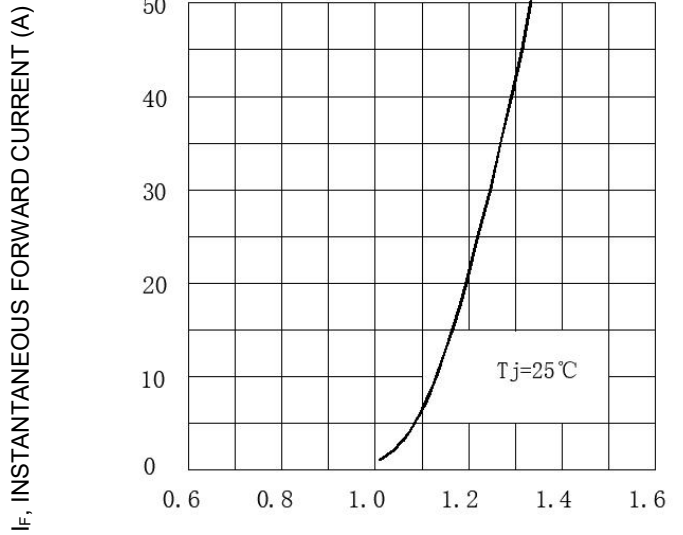

V_F , INSTANTANEOUS FWD VOLTAGE (V)
Fig.2 Maximum Forward Characteristics, per element

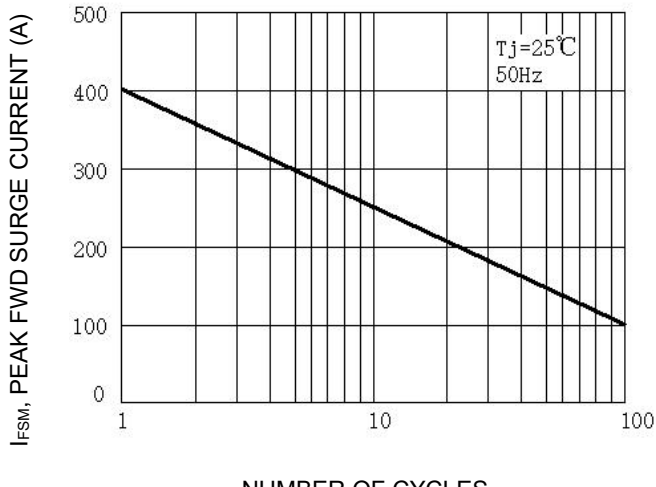

NUMBER OF CYCLES
Fig.3 Max Non-Repetitive Surge Current





SGBJ3508 THRU SGBJ3516

Glass Passivated Single Phase Bridge Rectifiers

Package Outline Information

CASE: SGBJ

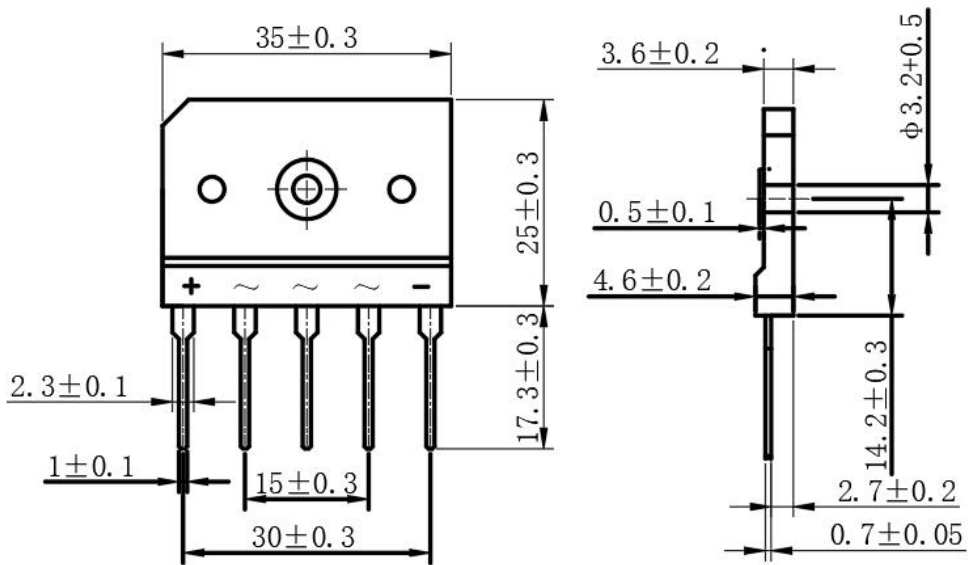

Dimensions in inches (mm)

X-ON Electronics

Largest Supplier of Electrical and Electronic Components

Click to view similar products for [Bridge Rectifiers](#) category:

Click to view products by [Juxing Electronic Technology](#) manufacturer:

Other Similar products are found below :

[MB2510](#) [MB252](#) [MB356G](#) [MB358G](#) [GBJ1504-BP](#) [GBU10B-BP](#) [GBU15K-BP](#) [GBU4A-BP](#) [GBU4D-BP](#) [DB101-BP](#) [DF01](#) [DF10SA-E345](#)
[KBPC50-10S](#) [RS405GL-BP](#) [GBJ1502-BP](#) [GBU6M](#) [TB102M](#) [MB1510](#) [MB86](#) [TL401G](#) [MDA920A2](#) [TU602](#) [TU810](#) [MP5010W-BP](#)
[MP501W-BP](#) [MP502-BP](#) [KBPC25-02](#) [VBO160-12NO7](#) [VS-110MT120KPBF](#) [VS-60MT80KPBF](#) [DB105-BP](#) [DF1510S](#) [VS-](#)
[40MT160PAPBF](#) [GBU4G-BP](#) [GSIB15A80-E3/45](#) [DB104-BP](#) [D3SB60](#) [TB354](#) [GBJ2504-BP](#) [26MB100A](#) [B1S-G](#) [VS-40MT160KPBF](#)
[VUO162-16NO7](#) [ABS10-G](#) [GBU6B-BP](#) [GBJ1508-BP](#) [BR5010-G](#) [ABS6-G](#) [B125C800G-E4/51](#) [MSB15MH-13](#)