

Specification

(Reference)

Title: ESD SUPPRESSOR; RECTANGULAR TYPE

Style: HSPC10, 16

RoHS COMPLIANCE ITEM

Product specification contained in this specification
are subject to change at any time without notice
If you have any questions or a Purchasing Specification for any quality
Agreement is necessary, please contact our sales staff.



釜屋電機株式會社
KAMAYA ELECTRIC CO., LTD.

Issue Dept.: Research & Development Department Hokkaido Research Center

1. Scope

1.1 This specification covers the detail requirements for ESD suppressor; rectangular type, style of HSPC10,16.

2. Classification

Type designation shall be the following form.

(Example) HSPC 16 701 B 02 TP
 1 2 3 4 5 6

1 ESD suppressor; rectangular type  Style

2 Size

3 Peak voltage Example: 701 → 700(V), 601→600(V)

4 Rated voltage

Symbol	Rated voltage
A	30V max
B	20V max
C	50V max

5 Optional code

Symbol	Optional code
01	Capacitance: 0.1 pF max.
02	Capacitance: 0.2 pF max.

6 Packaging form

3. Rating

3.1 The ratings shall be in accordance with Table-1.

Table-1

Style	ESD capability *1			Rated voltage (V)	Capacitance (pF) *2	Leakage current (μA)
	Peak voltage (V)	Clamping voltage (V)	ESD pulse withstand (pulses)			
HSPC10	600 max.	100 max.	100	30 max.	0.1 max.	1 max.
HSPC16	700 max.	100 max.	100	20 max.	0.2 max.	1 max.
				50 max.		

Style	Category temperature range (°C)
HSPC10	-55 to +125
HSPC16	

*1 Peak voltage: IEC61000-4-2, 15kV, Aerial discharge, The peak voltage shall be measured.

Clamping voltage: IEC61000-4-2, 15kV, Aerial discharge, The voltage value shall be measured after 30ns from the peak voltage.

ESD pulse withstand: IEC61000-4-2, 15kV, Aerial discharge, The pulse withstand.

*2 Capacitance: 25°C, 1MHz, 1Vrms

4. Packaging form

The standard packaging form shall be in accordance with Table-2.

Table-2

Symbol	Packaging form		Standard packaging quantity / units	Application
B	Bulk (loose package)		1,000 pcs.	HSPC10, 16
TH	Paper taping	8mm width, 2mm pitches	10,000 pcs.	HSPC10
TP	Paper taping	8mm width, 4mm pitches	5,000 pcs.	HSPC16

5. Dimensions

5.1 The suppressor shall be of the design and physical dimensions in accordance with Figure-1 and Table-3.

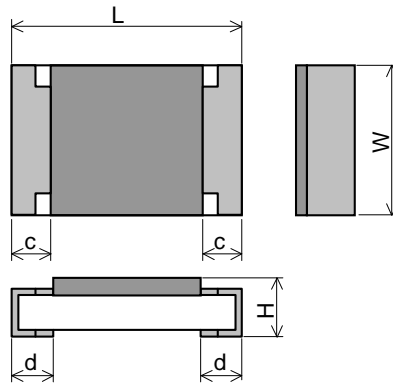
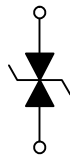

Figure-1
Table-3

Unit:mm

Style	L	W	H	c	d
HSPC10	1.0±0.05	0.5±0.05	0.35±0.05	0.2±0.1	0.25±0.10
HSPC16	1.6±0.1	0.8 ^{+0.15} _{-0.05}	0.5±0.1	0.3±0.1	0.3±0.1

5.2 Equivalent circuits



5.3 Net weight (Reference)

Style	Net weight(mg)
HSPC10	0.6
HSPC16	2

6. Performance

6.1 Unless otherwise specified, the standard range of atmospheric conditions for tests is as follows;

Ambient temperature: 5 °C to 35 °C, Relative humidity: 45 % to 85 %, Air pressure: 86 kPa to 106 kPa

If there is any doubt the results, measurements shall be made within the following:

Ambient temperature: 20 °C ± 2 °C, Relative humidity: 60 % to 70 %, Air pressure: 86 kPa to 106 kPa

6.2 The performance shall be satisfied in Table-4.

Table-4(1)

No.	Test items	Condition of test	Performance requirements
1	ESD capability Peak voltage	IEC61000-4-2 The suppressor shall be mounted on the test substrate as shown in Figure-2. Test condition: 15kV, Aerial discharge Measurement: The peak voltage shall be measured.	See Table-1.
2	ESD capability Clamp voltage	IEC61000-4-2 The suppressor shall be mounted on the test substrate as shown in Figure-2. Test condition: 15kV, Aerial discharge Measurement: The voltage value shall be measured after 30ns from the peak voltage.	100V max.

Table-4(2)

No.	Test items	Condition of test	Performance requirements
3	ESD capability ESD pulse withstand	IEC61000-4-2 The suppressor shall be mounted on the test substrate as shown in Figure-2. Test condition: 15kV, Aerial discharge Applied pulses: 100 pulses Measurement: After examination, the current value when the rated voltage is applied is measured.	10μA max.
4	Capacitance	Measurement condition: Frequency: 1MHz±10% Voltage: 1 Vrms±0.2Vrms Ambient temperature:25°C± 2 °C	See Table-1.
5	Leakage current	Measurement voltage: The rated voltage Measurement: The current value when the measurement voltage is applied is measured.	1μA max.
6	Terminal bond strength of the face plating	JIS C 61000-2-21 The suppressor shall be mounted on the test substrate as shown in Figure-2. Bending value: 3 mm (Among the fulcrums: 90 mm) Duration: 10 s ± 1 s	Leakage current: 10μA max. No evidence of mechanical damage.
7	Resistance to soldering heat	JIS C 60068-2-58 Test by a piece. Temp. of solder bath: 260 °C ± 5 °C Immersion time: 10 s ± 1 s After immersion into solder, leaving the room temp. for 48h or more, and then measure the leakage current. • Reflow soldering Pre-heating: 150 °C ~ 180 °C, 120 s max. Peak: 260 °C ± 5 °C, 10 s max. Reflow cycle: 2 times After immersion into solder, leaving the room temp. for 48h or more, and then measure the leakage current.	Leakage current: 10μA max. No evidence of appearance damage
8	Solderability	JIS C 60068-2-58 Test by a piece Flux: Rosin-Methanol Temp. of solder: bath: 235 °C ± 5 °C Immersion time: 2 s ± 0.5 s	The surface of terminal immersed shall be min. of 95 % covered with a new coating of solder.
9	Solvent	JIS C 60068-2-45 The specimen shall be cleansed at normal temperature for 90s using Isopropyl alcohol.	No evidence of appearance damage
10	Rapid change temperature	JIS C 60068-2-14 The suppressor shall be mounted on the test substrate as shown in Figure-2. Lower temperature: -55 °C Upper temperature: +125 °C Duration of exposure at each temperature: 30 min. Number of cycles: 100 cycles After examination, leaving the room temp. for 48h or more, and then measure the leakage current.	Leakage current: 10μA max. No evidence of appearance damage

Table-4(3)

No.	Test items	Condition of test	Performance requirements
11	Humidity (Steady state)	JIS C 60068-2-78 The suppressor shall be mounted on the test substrate as shown in Figure-2. Test temp. & relative humidity: 60±2°C & 90~95% RH. Test period: 1,000 ⁺⁴⁸ ₀ h After examination, leaving the room temp. for 48h or more, and then measure the leakage current.	Leakage current: 10μA max. No evidence of appearance damage
12	Load life in humidity	The suppressor shall be mounted on the test substrate as shown in Figure-2. Test temp. & relative humidity: 60±2°C & 90~95% R.H. Test voltage: The rated voltage shall be applied continuously. Test period: 1,000 ⁺⁴⁸ ₀ h After examination, leaving the room temp. for 48h or more, and then measure the leakage current.	Leakage current: 10μA max. No evidence of appearance damage
13	Endurance at 85 °C	The suppressor shall be mounted on the test substrate as shown in Figure-2. Test temp.: 85±2°C Test voltage: The rated voltage shall be applied continuously. Test period: 1,000 ⁺⁴⁸ ₀ h After examination, leaving the room temp. for 48h or more, and then measure the leakage current.	Leakage current: 10μA max. No evidence of appearance damage

7. Test substrate

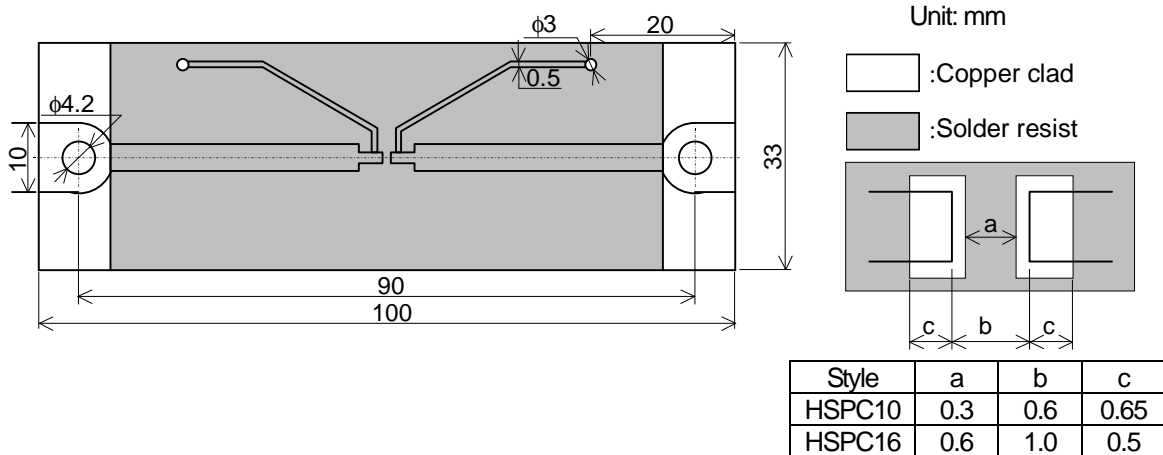

Figure-2 HSPC TEST SUBSTRATE

Remark 1). Material: Epoxide woven glass
Thickness: 1.6mm Thickness of copper clad: 0.035mm

8. Taping

8.1 Applicable documents JIS C 0806-3: 1999, EIAJ ET-7200B: 2003

8.2 Taping dimensions

8.2.1 Paper taping (8mm width, 2mm pitches)

Taping dimensions shall be in accordance with Figure-3 and Table-5.

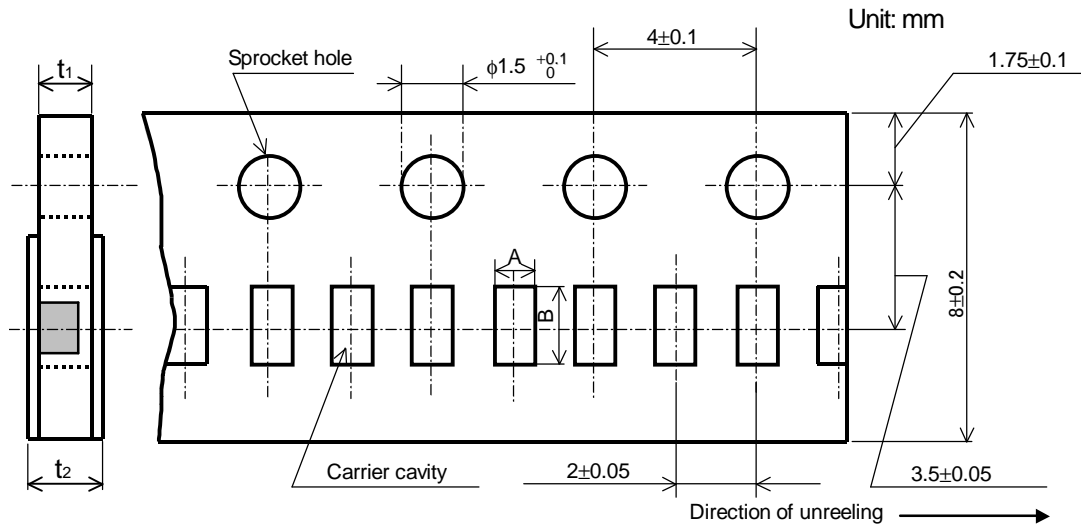

Figure-3

Table-5

Style	A	B	t ₁	t ₂
HSPC10	0.65 ^{+0.05} / _{-0.10}	1.15 ^{+0.05} / _{-0.10}	0.4 ± 0.05	0.5max.

8.2.2 Paper taping (8mm width, 2mm pitches)

Taping dimensions shall be in accordance with Figure-4 and Table-6.

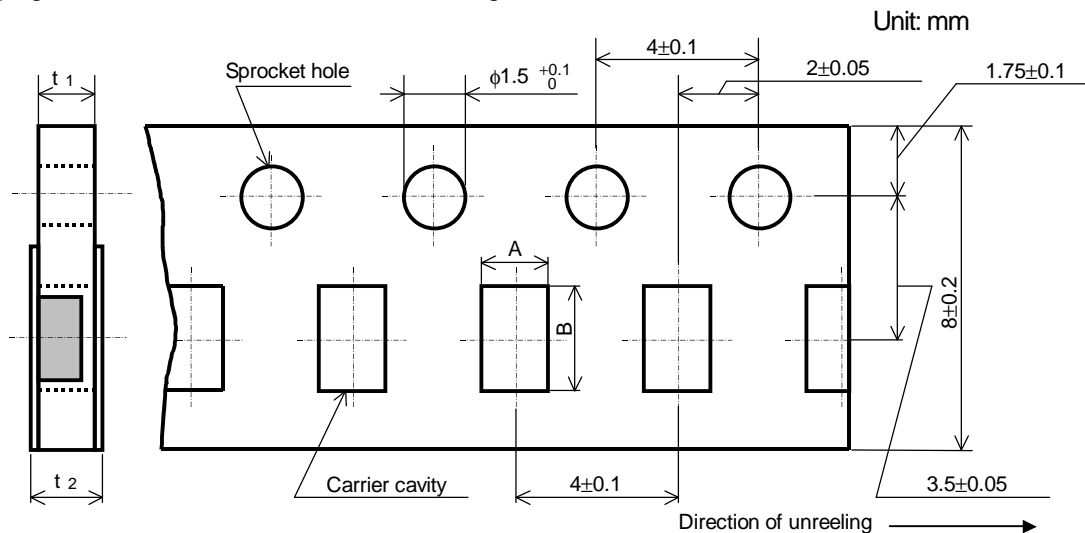

Figure-4

Table-6

Style	A	B	t ₁	t ₂
HSPC16	1.15±0.15	1.9±0.2	0.6±0.1	0.8max.

- 1). The cover tapes shall not cover the sprocket holes.
- 2). Tapes in adjacent layers shall not stick together in the packing.
- 3). Components shall not stick to the carrier tape or to the cover tape.
- 4). Pitch tolerance over any 10 pitches $\pm 0.2\text{mm}$.
- 5). The peel strength of the top cover tape shall be with in 0.1N to 0.5N on the test method as shown in the following Figure-5.
- 6). When the tape is bent with the minimum radius for 25 mm, the tape shall not be damaged and the components shall maintain their position and orientation in the tape.
- 7). In no case shall there be two or more consecutive components missing.
The maximum number of missing components shall be one or 0.1%, whichever is greater.
- 8). The suppressors shall be faced to upward at the over coating side in the carrier cavity.

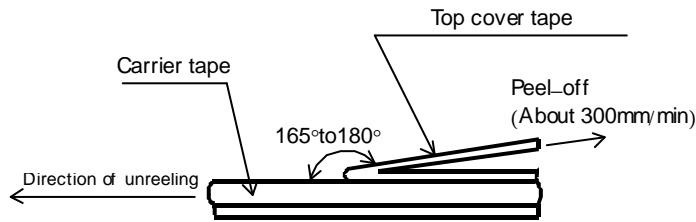

Figure-5

8.3 Reel dimension

Reel dimensions shall be in accordance with the following Figure-6 and Table-7.

Plastic reel (Based on EIAJ ET-7200B)

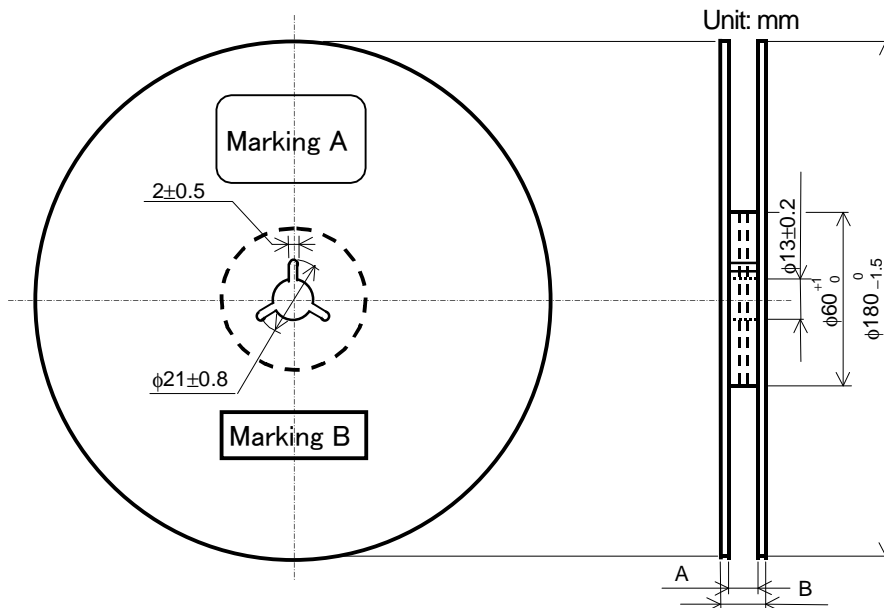

Figure-6

Table-7

Style	Unit: mm		Note
	A	B	
HSPC10,16	9 $^{+1.0}_0$	11.4±1.0	Injection molding
		13±1.0	Vacuum forming

Note: Marking label shall be marked on a place of Marking A or two place of marking A and B.

8.4 Leader and trailer tape.

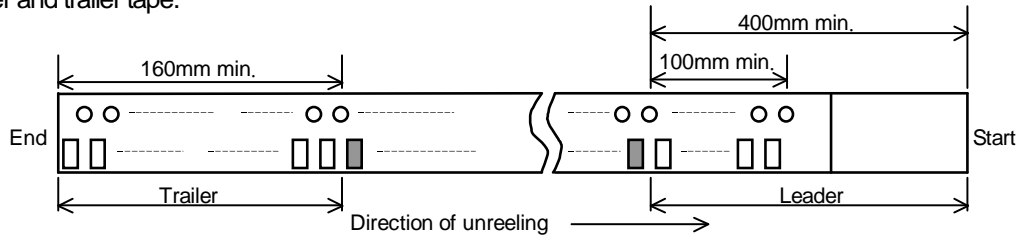

Figure-7

9. Marking on package

The label of a minimum package shall be legibly marked with follows.

9.1 Marking A

- (1) Classification (Style, Peak voltage, Rated voltage, Optional code, Packaging form) (2) Quantity (3) Lot number
(4) Manufacturer's name or trade mark (5) Others

9.2 Marking B (KAMAYA Control label)

X-ON Electronics

Largest Supplier of Electrical and Electronic Components

Click to view similar products for [ESD Suppressors](#) category:

Click to view products by [Kamaya](#) manufacturer:

Other Similar products are found below :

[82356050220](#) [D5V0M5U6V-7](#) [DSILC6-4F2](#) [EMIF02-MIC03M6](#) [ESD12VD3-TP](#) [ESD5V0J4-TP](#) [ESD7451N2T5G](#) [CPDT-5V0USP-HF](#)
[VBUS054DD-HF4-GS08](#) [VBUS54DD-HS4-G4-08](#) [EMIF03-SIM02F2](#) [EMIF07-LCD02F3](#) [SCM1293A-04SO](#) [82356240030](#) [TQP200002](#)
[VESD12A1A-HD1-GS08](#) [CPDUR5V0R-HF](#) [ESD3V3D7-TP](#) [ESDA6V1LY](#) [ESDAVLC12-1BV2](#) [EMIF06-USD05F3](#) [EMIF06-USD04F3](#)
[EMIF03-SIM03F3](#) [GMF05LC-HSF-GS08](#) [CM1263-06DE](#) [CPDQ5V0USP-HF](#) [CPDU12V0U-HF](#) [CPDU5V0USP-HF](#) [RCLAMP3324P.TNT](#)
[RCLAMP7534P.TNT](#) [TPD1E0B04DPLT](#) [TPD1E10B09QDPYRQ1](#) [MMBZ27VCL,215](#) [MMBZ33VCL,215](#) [IP4786CZ32S,118](#)
[DF2S5.6ASL,L3F](#) [DF2S5.6FS\(TPL3\)](#) [DF2S6.2ASL,L3F](#) [DF2S6.2CT,L3F](#) [DF2S6.8FS,L3M](#) [DF2S8.2FS,L3M](#) [DF5A5.6JE,LM](#)
[EMI5206MUTAG](#) [EMI6316FCTBG](#) [EMI8141MUTAG](#) [EMIF03-SIM05F3](#) [MSMP13A-M3/89A](#) [ESD5V0D5-TP](#) [ESD5Z6.0T5G](#)
[ESD7321MUT5G](#)